

Computer Graphics Products OEM Imaging Plug-in Oscilloscopes Portable Oscilloscopes Logic Analyzers Data Comm Testers General Purpose Instruments Signal Processing Systems Semiconductor Test Systems Curve Tracers Cable Testers Microcomputer Development Products TV Demodulators, Vectorscopes, Generators, Waveform & Picture Monitors Automatic Measurement System Spectrum Analyzers & Swept Frequency System Testers-TDR Photometer/Radiometer Cameras, Probes, Carts, & Accessories

Introducing a year of 50 new products and a new company structure.

Tek's 1982 Catalog is thicker by some 60 pages. Over 50 new products are being offered this year providing the superior performance, increased productivity and unmatched value you expect from Tektronix. Each major product introduction is marked **NEW** for easy reference.

And, there's more news.

This year's catalog is organized to reflect Tek's new decentralized, divisional structure. Each Division is virtually a self-contained entity with its own engineering, manufacturing, marketing and sales responsibilities.

Each Tektronix Sales Engineer now specializes in the products and applications for a major area of customer activity: digital design and test, computer graphics, communications, and general test and measurement.

You can receive additional product information by calling your nearest Tektronix Sales Office listed on pages 366-368 or by returning the reply card attached between pages 208 and 209.



IMPORTANT INFORMATION

REFERENCE IEEE-488

2

An overview of some of the important factors involved in selecting products to meet your needs. Tektronix GPIB product systems are described, as well as individual waveform measurement instruments, graphic controllers, and peripherals.

DESIGN AUTOMATION DIVISION

MICROCOMPUTER DEVELOPMENT PRODUCTS

12

The 8500 Series offers the broadest range of quality multiple microprocessor and microcomputer development support available today.

INFORMATION DISPLAY DIVISION

COMPUTER GRAPHICS PRODUCTS

67

A wide range of computer display terminals, desktop computers, graphic peripheral products and supporting software.

COMMUNICATIONS DIVISION

TELEVISION PRODUCTS

103

TEKTRONIX Television Products time, test, measure, correct and display the television signal world-wide.

INSTRUMENTS DIVISION

SIGNAL PROCESSING SYSTEMS

143

Waveform Digitizing Instruments and Systems, practical solutions to measurement problems and analysis through the use of specifically designed digitizers, systems and software.

LABORATORY AND PORTABLE OSCILLOSCOPES

148

Versatile, easy-to-operate oscilloscope fam-

POWER SOURCE CONSIDERATIONS 10

Material on power sources and power cord /plug options.

ENVIRONMENTAL CHARACTERISTICS 10

Information about how to interpret environmental specifications.

SERVICE & SUPPORT 351

Details about ordering, training, calibration, maintenance, repairs, parts, service, terms of sale and warranty.

TERMS OF SALE 356

Information on prices, terms, shipping estimates, and best method of transportation on Tektronix products, accessories and replacement parts.

INDEXES 357

Functional and alphanumeric indexes for quick easy access.

SALES & SERVICE OFFICES 366

A complete listing of Tektronix worldwide sales and service offices. Consult the listing for the one nearest you.

DATA COMMUNICATION ANALYZERS 26

The 830 Series family of Data Communications Testers are designed to identify faulty elements in a data communications network. The 834 offers a high degree of programmability which allows easy go/no-go testing.

The 851 Digital Tester is a first-line, multifunctional service instrument developed to meet the needs of the digital service industry.

SEMICONDUCTOR TEST SYSTEMS 36

Tektronix offers comprehensive solutions for automated test and measurement problems encompassing linear and digital ICs, LSI devices, Microprocessors and discrete components.

LOGIC ANALYZERS 43

Tektronix Logic Analyzers save time and money in designing, evaluating, manufacturing and servicing digital products. From 8 to 104 channels with sophisticated modules for high speed timing analysis, stimulation of the circuit under test, and microprocessor analysis.

OEM IMAGING PRODUCTS 94

For both OEM and end-users, we offer a wide range of display monitors for direct viewing or photography; X-Y (random dot scan or vector) and raster scan (video) displays. Modular Packaging is available on many instruments.

CABLE TESTERS/TDR 116

These TDR cable testers provide installation and maintenance people with fast, accurate, portable tools for checking the internal condition of cables and locating faults.

SPECTRUM ANALYZERS 118

High performance 490 Series Compact Spectrum Analyzers covering 50 kHz to 220 GHz with full programmability/GPIB option and ease of operation features. 7000 Series compatible, lab grade plug-in spectrum analyzer family covering 20 Hz to 60 GHz.

ilies, with your choice of plug-in or portable configurations. From 500 kHz to 1 GHz bandwidth. Conventional, dual beam oscilloscopes. Multimode, variable persistence storage, waveform digitizers, realtime and sampling, choose the configuration that fits your application.

IEEE-488 PROGRAMMABLE AND MANUAL GENERAL PURPOSE INSTRUMENTS 250

The TM 5000 introduces a new group of products, fully programmable via the IEEE-488

bus, and provides state-of-the-art calibration standards. The new programmables are compatible with over 40 TM 500 manual instruments. You link together literally hundreds of customized systems. Programmable, manual, or mixed.

CURVE TRACERS 301

Curve Tracers can deliver comprehensive information about a multitude of semiconductor devices and integrated circuits.

PHOTOMETER/RADIOMETER 311

A lightweight, portable digital photometer/radiometer with probes for measuring luminance, illuminance, irradiance, light-emitting diode output, and relative intensity.

CAMERAS, PROBES, CARTS AND ACCESSORIES 315

Extend your measurement capabilities. Contains selection guides, charts, descriptions, and specifications.

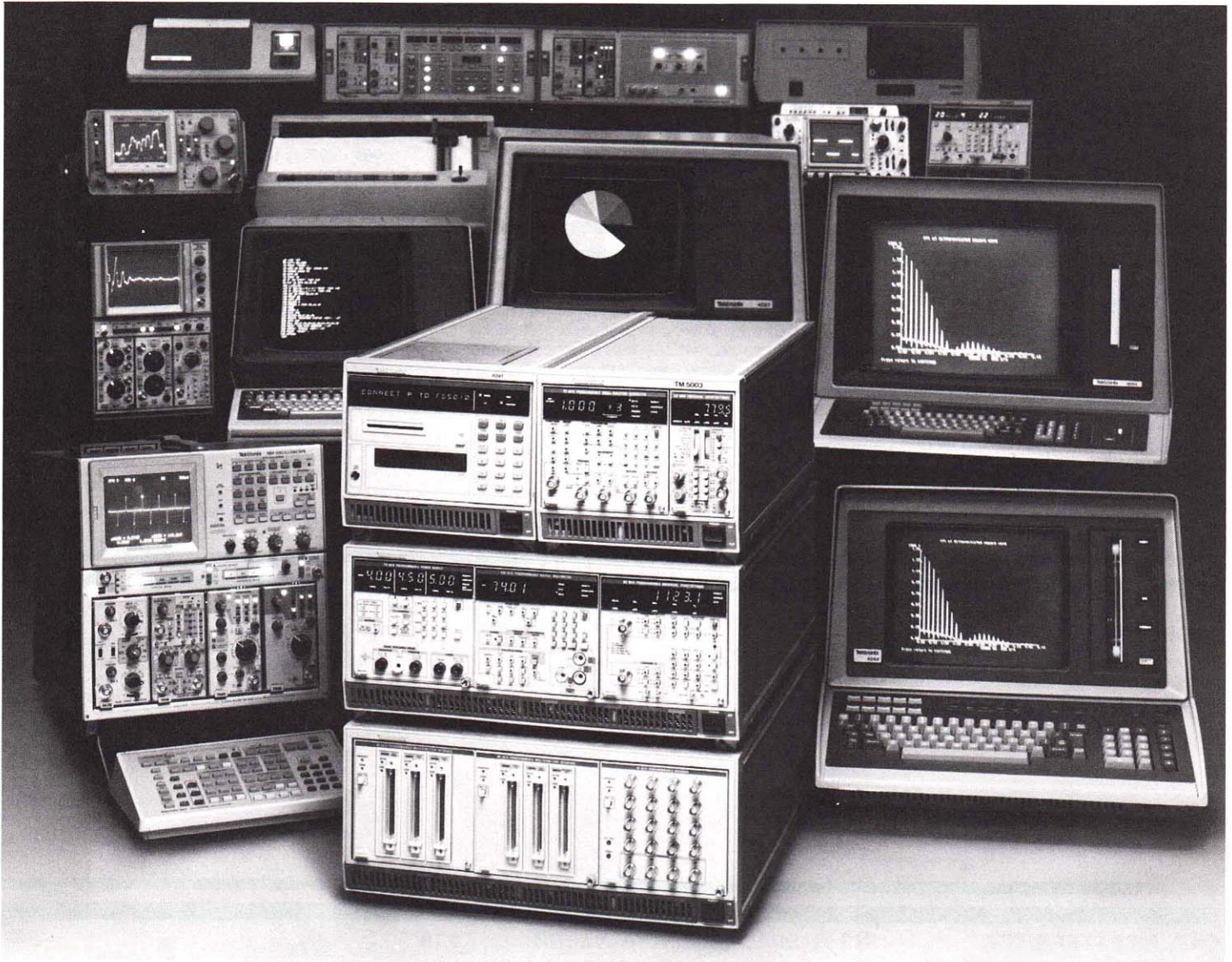

As measurement needs grew in number and complexity over the past few decades, people began to realize that traditional design and test procedures were becoming inadequate. When the inadequacies became intolerable, special interfaces were designed and various instruments were connected to controllers to form specialized test systems. From these beginnings, some major benefits of automated test and measurement were quickly realized:

- Test and measurement labor costs were reduced.
- Human error decreased through precise and repeatable automation of measurements.
- Skilled people were released from mundane or repetitive procedures to pursue more creative research and design activities.
- Sophisticated analysis techniques could routinely be applied to provide greater insight into devices and processes.

But, for all their benefits, automated test and measurement systems still had some significant problems. Mostly, these stemmed from each system being unique, custom built. The automation need had to be severe to justify custom design costs. Systems and data formats were not generally compatible with each other. And changing the system or adding instruments meant another custom design effort.

Test and measurement automation was still too fragmented and costly for general use, even though the benefits were generally needed. A standard interfacing system providing across-the-board compatibility for a variety of instrumentation and instrument controllers seemed to be the solution.

GPIB—The First Step Toward Compatibility

In 1975, the first major step toward general compatibility in electronic instrumentation for systems use was taken. This step was IEEE publication of the 488 standard defining an interface and communications bus for programmable instruments. This standard bus is commonly called the GPIB--the General Purpose Interface Bus.

IEEE Standard 488, which was further refined in 1978, defines an interfacing system that has become a widely accepted instrument industry standard. The major areas it specifies are:

1. Mechanical--the interface connector and cable.
2. Electrical--the logic signal levels and how the signals are sent and received.
3. Functional--the tasks an instrument's interface may perform--such as sending data, receiving data, triggering the instrument, etc.--and the protocols to be used.

Today, a wide variety of instruments include interfaces conforming to this mechanical, electrical, and functional standard. These GPIB-compatible instruments and instrument controllers make it possible to achieve the benefits of automated test systems without paying the previous price of custom system design. With GPIB compatibility, measurement capability can be chosen off-the-shelf and simply cabled with standard bus cables in either a linear or star configuration.

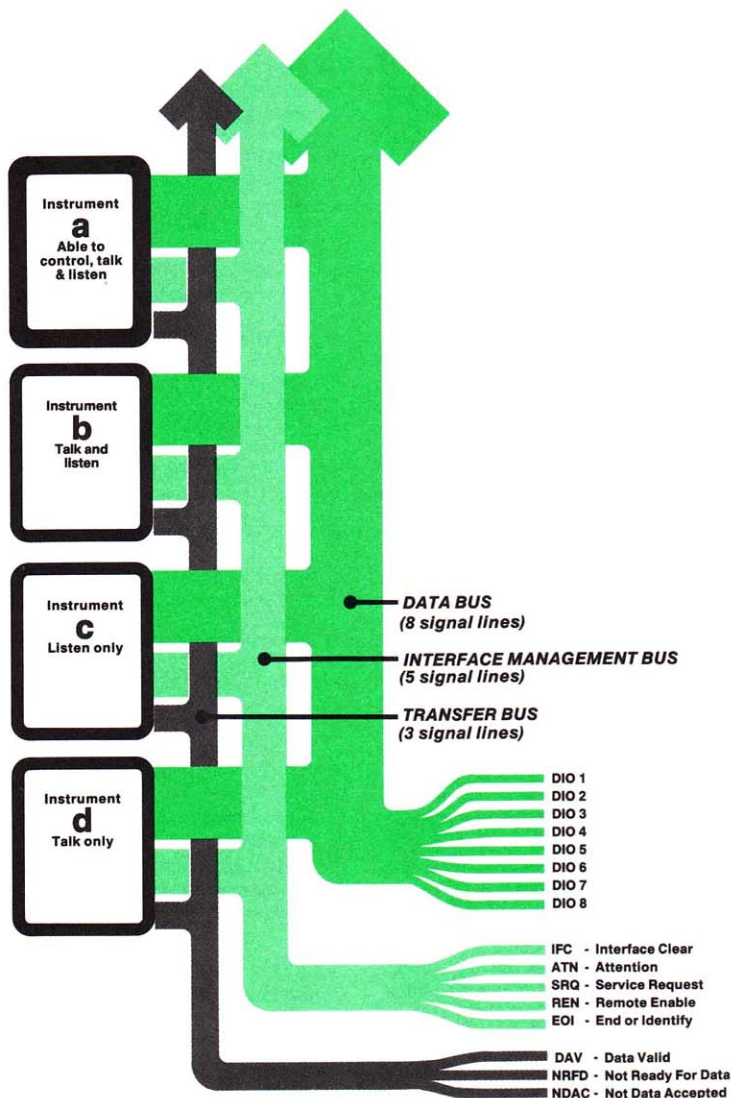

GPIB HARDWARE CHARACTERISTICS

- Cable length of up to 20 meters (approximately 66 feet) with a device load for every 2 meters of cable (i.e., cable length $\leq 2X$ number of instruments).
- Up to 15 devices (1 controller and 14 instruments) may be connected in linear or star configurations.
- Voltages are generally TTL-compatible.

- GPIB signal and data lines are asserted (or true) when pulled low ($\leq +0.8$ V) and released (or false) when pulled high ($\geq +2.0$ V).
- Maximum data rate of up to 250 kilobytes/second over a distance of 20 meters with 2 meters per device or faster with some special restrictions (refer to IEEE Standard 488-1978 for details).

Interface Functions Defined by IEEE-488 1978

| Function | Description |
|-------------------------|--|
| Talker (T) | Allows instrument to send data |
| Listener (L) | Allows instrument to receive data |
| Source Handshake (SH) | Synchronizes message transmission |
| Acceptor Handshake (AH) | Synchronizes message reception |
| Remote-Local (RL) | Allows instrument to select between GPIB interface and front-panel programming |
| Device Clear (DC) | Puts instrument in initial state |
| Device Trigger (DT) | Starts some basic operation of the instrument |
| Parallel Poll (PP) | Allows up to eight instruments simultaneously to return a status bit to the controller |
| Controller (C) | Sends device addresses and other interface messages |

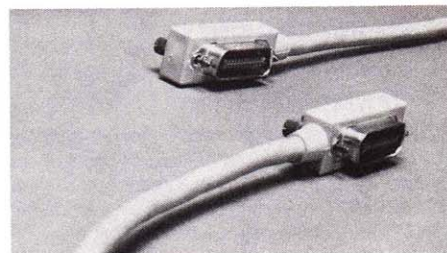

Tektronix' Systems Experience

Long before publication of the IEEE-488 Standard, Tektronix had entered the test and measurement systems business. The measurement speed and capabilities of the Tektronix automated oscilloscope and Tektronix semiconductor test systems quickly highlighted the benefits to be gained from measurement automation. And just as quickly came the realization that a system interfacing standard was needed. But what standard?

The possibilities of the proposed IEEE-488 standard were recognized. And, when the IEEE-488 standard became reality, GPIB compatibility was already an integral part of Tektronix product planning and engineering. The result is that Tektronix is now a recognized major supplier of a full line of GPIB system components—a supplier that puts more than a decade of systems planning, design, and implementation experience into each product.

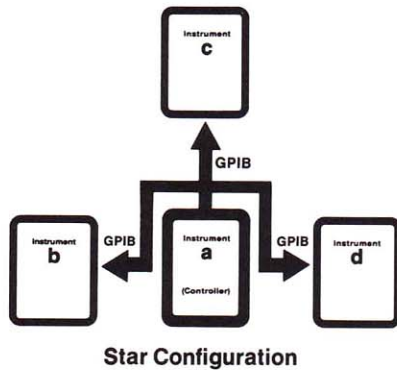
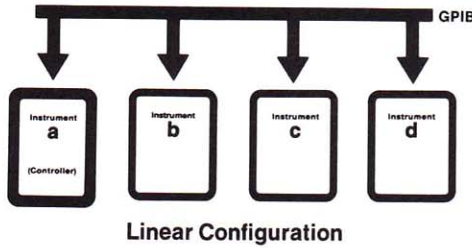

The software and the program in the controller make the system do what the user wants. The GPIB interface allows users to plug system components together, but without software, the system can do nothing.

In programmable instrument systems, the "language" of the software or program has several meanings:

1. The controller has its own language, such as BASIC, and users must express their intentions in this language.
2. Within the context of the controller's language, the instrument's commands (or "language") have to be sent over the GPIB.
3. The actual control of the GPIB interface is transparent to the user with Tektronix instrument controllers and software.

In order to make the system operate, the user has to:

1. Know what tasks the system is to perform--the system can do nothing by itself.
2. Know the controller's language.
3. Know the kind of data or language the instruments are designed to exchange.

To make these tasks easier for you, Tektronix has taken several steps beyond simple IEEE-488 compatibility. Consistency has been designed into each system component for the greatest degree of compatibility. Intelligence has been designed in to relieve you from niggling interfacing details. And firmware and software have been designed and written to provide the maximum in programming ease and measurement capability.

Consistency Makes a Big Difference

Tektronix GPIB products are designed and thoroughly evaluated for compliance with IEEE-488 and for compatibility with one another. Because these products are designed to be compatible (i.e., meet the same standards), users usually won't need to make hardware and software modifications for each new addition or deletion to the configuration. Many software routines need to be written only once, after which only minor modifications are needed with the addition of new instruments.

GPIB System Components

An automated test and measurement system usually consists of the following components:

- Multiple instruments: these are either *stimulus* instruments, such as frequency generators, pulse generators, and power supplies, or *measurement* instruments, such as counters, waveform digitizers, and multimeters.
- Controller with software: this tells the instruments what to do, collects the results, and processes them. The system controller is generally a small computer. The software or firmware operating system must have a powerful, flexible I/O structure to handle GPIB bus traffic. It must also have processing power for waveform manipulation and graphics power for display.
- Computer peripherals: these are devices such as tape drives, printers, and plotters that store or display the results of the tests.
- A keyboard: this enables the user to send commands or information to the system.
- A display: the display allows the user to review intermediate results and to monitor system operation.

For smaller systems, these last three components are often incorporated in the system controller--a desktop computer, such as the TEKTRONIX 4050 Series, that is specifically designed for use with instrument systems. Larger, more powerful systems, however, may be minicomputer-based, augmented by one or more high-speed mass storage devices, a graphic display terminal, and run under specialized instrument control and signal processing software such as TEK SPS BASIC.

All these components can be easily interconnected if the standard GPIB interface has been built in and appropriate functions made programmable. Before GPIB, most measurement systems were operated by controllers that required a separate connector (port) for each instrument. With the GPIB this is no longer a requirement. Users can directly link up to 14 instruments with the controller via the bus, and set up the systems in linear or star configurations. Additionally, some controllers can drive more than one GPIB port. The TEKTRONIX 4041 has an option for a second port, allowing control of up to 28 instruments. Or, if you need more, TEK SPS BASIC operated with a properly optioned DEC PDP-11 minicomputer can drive up to four GPIB ports, providing a total system potential of 56 instruments.

All these devices--the controller, measurement instruments, and peripherals--comprise the hardware. The system cannot operate, however, unless it is driven by software.

There are two levels of software necessary, the operating system software and the user written application programs. The operating system software provides a set of commands and functions that the user combines into a program that delineates the measurement and processing task to be performed. The software, guided by the user program, works through the controller to tell the instruments what signals to generate, what measurements to make, and tells the controller what to do with the results.

A status check routine, for instance, will work on all Tektronix GPIB instruments. A message terminator common to all Tektronix GPIB instruments is a further benefit. But, since the IEEE-488 Standard allows several optional message terminators, Tektronix instruments go an extra step by providing a switch for selecting optional terminators. These features provide users with the capability of quickly configuring and reconfiguring interactive and automated measurement systems.

The result is a line of products that are not only GPIB compatible—but are capable GPIB instruments with the features that make them useful and the compatibility that makes them work together.

Tektronix Codes and Formats Standard Means Programming Ease

The IEEE-488 Standard specifies the hardware interface and its basic functional protocol. It also specifies a set of codes called interface messages that control interface functions. However, the IEEE-488 Standard does not specify the syntax or coding of device-dependent messages—the messages that control the programmable features of the instrument.

Since the device-dependent messages are not specified, instruments that conform to the IEEE-488 Standard may use inconvenient or even incompatible message formats. It's much like a telephone system—the hardware link is well defined, but unless both parties speak the same language, communication is impossible. That's why Tektronix developed a Codes and Formats Standard that specifies the syntax and coding of device dependent messages, while retaining full IEEE-488 compatibility. The Tektronix *Codes and Formats* Standard specifies message coding to:

- be simple and unambiguous
- use commands that are common among similar devices
- use simple, easy-to-remember mnemonics.

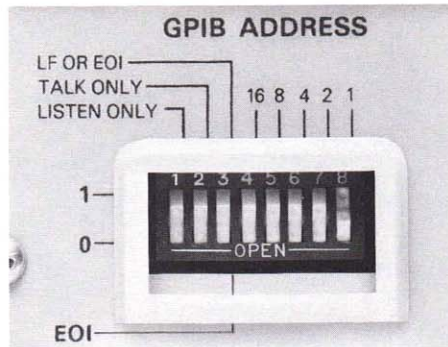

Each GPIB instrument or peripheral, called a device, must be assigned a different system address; this can be done simply by setting switches, usually located on the back panel of the device.

The benefits of the Tektronix *Codes and Formats* Standard are numerous. Codes and Formats is a major feature of the Tektronix GPIB communications protocol. Because of their natural English-like structure, instrument control commands and messages are easy to use. The result is a GPIB implementation that is specifically designed to overcome the programming rigidity and cumbersome procedures of other GPIB systems.

ASCII Data Standard. Since most controllers accept ASCII data directly, Tektronix GPIB instrument commands are coded in ASCII. This eliminates the need for error-prone data conversions or byte-by-byte encoding. For example, to set the center frequency of the 492P Spectrum Analyzer at 1.75 MHz, the command is simply written `FREQ 1.75 MHz`—no more calculated percentages of full-scale or BCD equivalents. Settings for Tektronix GPIB instruments are sent as ASCII data in human readable form.

Flexible Formats. Many minor format items that are aggravations in other systems are also taken care of by Tektronix Codes and Formats. For example, Tektronix GPIB instruments accept negative zeros and leading and trailing spaces; they also overlook inconsistent use of upper and lower

case letters. And, since truncated numbers can drastically affect measurements, Tektronix GPIB instruments round off rather than truncate: e.g., a value of 2.49 becomes 2.5 rather than 2.4. In short, the built-in intelligence is used to make intelligent decisions. That makes your programming job much less rigid and substantially easier.

Common Messages. To make things even easier, Tektronix Codes and Formats also specifies messages that are to be common to all Tektronix programmable instruments. For example, you can program your system to learn the current settings of any Tektronix GPIB instrument by sending the instrument the SET? message. Any GPIB compatible instrument from Tektronix—whether it is a waveform digitizer, a programmable power supply, or a function generator—interprets SET? the same way. The instrument firmware gathers the instrument's settings together and assembles them into a human readable message to be sent over the bus to the controlling software. If you know how to operate a function generator, then you already know how to read a settings message from a Tektronix GPIB compatible function generator.

BASIC Languages. Because users are increasingly interacting with GPIB systems at the controller keyboard rather than at instrument panels, GPIB systems must be as friendly as possible. This means, too, that the controller languages should be simple, logical, and easy to interpret and implement. That's why Tektronix Codes and Formats specifies BASIC as the language of preference for Tektronix instrument controllers.

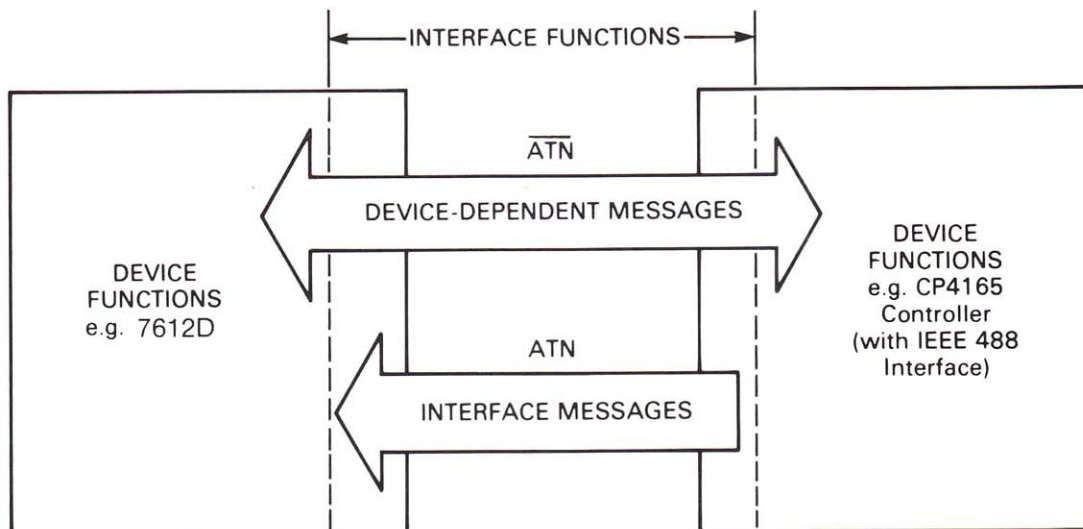

BASIC is an established language with wide use and familiarity. It is also an English-like language that is easy to learn and understand. So, combined with the English-like messages used with Tektronix GPIB instruments, it becomes a consistent and familiar means of communicating with your system. And your program listings are easy to read and follow, with very little interpretation required. (For more details on Tektronix *Codes and Formats*, ask your Tektronix Sales Engineer or Representative for Application Note 99AX-4607, "Tektronix Codes and Formats for GPIB Instruments.")

Controllers to Match Your Needs

With the introduction of the new 4041 System Controller, Tektronix now offers three controller-software packages to meet varying GPIB system needs. These packages are:

- the 4041 System Controller, optimized for instrument control in a variety of situations
- the 4050 Graphic Computing Systems, optimized for desk-top instrument control and computing with full graphics capabilities
- TEK SPS BASIC software with the DEC PDP-11 Series minicomputer, optimized for systems with full waveform acquisition, processing, and graphics.

The 4041 System Controller. The 4041 System Controller is a compact, modular controller designed for rackmount, bench-top, or portable use. Its operating system language is an extended BASIC designed for use by both the casual and the sophisticated programmer.

The 4041 controller contains three microprocessors, with the CPU being the powerful 16-bit 6800. Standard memory is 32 kilobytes with optional 32-kilobyte increments to a maximum of 160 kilobytes. A 20-character alphanumeric LED display, a 20-character thermal printer, a DC-100 cassette drive, 18 function keys, an IEEE-488 port, an RS-232 port, and a real-time clock and calendar capability are all standard. An additional IEEE-488/RS-232 port pair is optional, with the second IEEE-488 port having Direct Memory Access capability. With 14 GPIB instruments per IEEE-488 port, the 4041 System Controller offers the capability of controlling up to 28 GPIB instruments.

Also optional are an 8-bit parallel TTL port, program development ROMs with a carrier, and a detachable program development/debug keyboard.



The program development ROMs and keyboard, or an RS-232 terminal, give the engineer or production test programmer access to the system language. This language is an extended version of BASIC designed for use by all skill levels. Its English-like commands, simple syntax, and line-by-line interpreter implementation combine for a friendly and interactive system. A variety of other features are also included to increase friendliness. For example, variable names may be up to eight characters long, allowing meaningful names such as RISETIME, VOLTAGE 1, or DELAY. And, as another example, subprograms and program lines can be named—e.g., 1000 SRQPOLL: or 200 RMS VOLTS:—for quick and easy access.

Beyond enhancements for simplicity, 4041 BASIC also has enhancements that make it a powerful tool for sophisticated programmers, too. It includes capabilities for FORTRAN-like subprograms, variable passing from main to subprograms, declaration of local and global variables, and many other features.

Yet, for all its sophistication, the 4041 is still particularly desirable for use by low-skill operators in a production environment. Instrument control programs can be designed and written to print user prompts on the 4041 display and the programs can be assigned to any of the ten user-definable keys on the 4041 front panel. Then the

4041 program development keyboard and ROM pack carrier can be removed from the controller. This puts the 4041 into an execute only mode with its programs protected. The low-skilled user need only follow the front-panel display prompts and press the designated keys to execute programs.

To return to the engineering or program development mode, simply plug the program development ROM pack carrier and keyboard or an RS-232 terminal back into the 4041. You again have access to all of the ease and power of 4041 BASIC programming.

The Tektronix 4050-Series Graphic Computing Systems. The 4050-Series systems are especially convenient for engineering bench or laboratory support of GPIB compatible instruments. The typewriter keyboard, built-in calculator keypad, and special programmable keys provide easy operation. In addition, the IEEE-488 interface port provides for control of up to 14 GPIB instruments at a time.

TEKTRONIX 4050 Series Systems have an exclusive high-resolution storage display for unexcelled graphic clarity and detail. There is no distracting screen flicker. All lines are continuous, never detracting from or distorting information.

This built-in graphics capability allows interactive graphic manipulation to help visually analyze waveform data before it is processed. A user can often gain valuable insights or decide to investigate a new direction once the acquired data is graphically displayed.

Supporting the advanced, interactive graphics capability is powerful computer performance. Features such as full array processing, an invaluable tool for handling whole waveforms, and dynamic memory allocation, both reduce the worry about data movement in the system.

Additionally, a range of peripheral products are available with TEKTRONIX 4050 Series Desktop Computer Systems to provide analysis records in many sizes and formats. Tektronix peripheral products include hard copy units, digital plotters, graphic input tablets, and disc memory systems.

With 4050 Series Systems, you can immediately start using a high-level extended BASIC. This universal technical language is well adapted to technical needs of the user and includes extensions for increased computation power and further ease of use.

Tektronix also supplies general utility software programs for various communication routines, such as bi-directional transferring of waveform data, test results, and instrument settings. And acquired data can be quickly graphed on the display screen. Graphic waveform handling is enhanced by built-in features such as auto-scaling, where unknown quantities of waveform data can be scaled into a defined set of graphic coordinates by a few key-stroke operations. Coordinates may be defined for Log-Lin, Log-Log, or even Smith Chart and Bode plots--whichever is relevant to your application. Any of the displays can be quickly copied to paper.

Some of the more common signal processing tasks can be accomplished using firmware supplied by Tektronix. Plug-in ROM packs for the 4050 Series controllers provide specialized waveform processing commands. For example, the Signal Processing ROM Packs use versatile English-like commands to handle data arrays or whole waveforms.

Other ROM pack capabilities include fast Fourier and inverse Fourier operations to make harmonic analysis of waveform data. The fast Fourier can transfer whole waveforms from time domains to frequency domains in a matter of seconds; they are always under the user's direct control.

Still other ROM packs offer a real-time clock, advanced graphic handling features, data conversion packages, and other computational tools.

TEK SPS BASIC Software with DEC PDP-11 Minicomputers. When equipped with Tektronix supplied IEEE-488 interfaces, all PDP-11 series minicomputers can be operated with TEK SPS BASIC software to provide the most powerful of big-system instrument control and signal processing. A wide variety of peripherals can be handled, including plotters, line printers, graphic terminals, magnetic tapes, and single or multiple disk storage systems. Additionally with the proper options, up to four IEEE-488 interface ports can be supported. This means control of and data collection from up to 56 GPIB instruments.

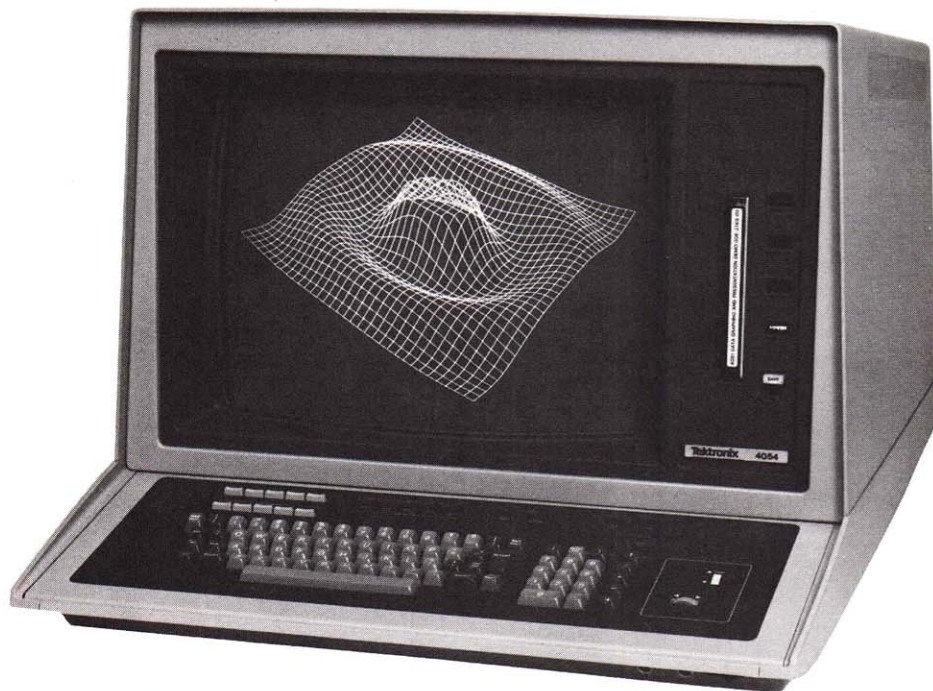

TEKTRONIX 4054 Desktop Computer

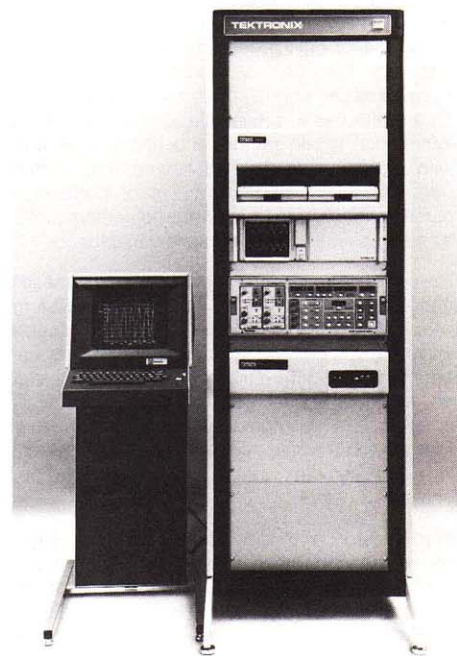

TEKTRONIX WP3202 Signal Processing System using TEK SPS BASIC and a DEC PDP-11 Minicomputer

Two versions of TEK SPS BASIC are available, the standard version and the extended memory version. The extended memory version permits processing of very large arrays in computers having up to 128 k of memory with memory management.

Other than memory differences, both versions of TEK SPS BASIC software have the same major features. These include a modular architecture consisting of a resident monitor and an expandable library of over 100 nonresident commands. This unique design lets you configure a software system to meet your specific needs yet leaves the system open for adding new commands and processing modules.

Measurement data can be stored and accessed in a variety of ways. Information can be read or written in either ASCII or binary. Named files can be accessed on hard or flexible disks, magnetic tape, cassettes, or paper tape. Information can be read from files either sequentially or randomly. TEK SPS BASIC commands give you complete file management capability.

Comprehensive graphics permit waveform plots and X-Y plots between waveforms. Either can be done with single commands. The output is complete with scaled and labeled axes and can be hard-copied to paper.

There's also data logging capabilities for automated waveform capture. And the software's better than 7-digit precision means much higher resolution than possible in conventional oscilloscope measurements. Plus, there are special data structures to retain both numeric and literal information (scale factors and units) associated with a given waveform. This waveform data structure, as well as numeric arrays or portions of numeric arrays, can be operated on arithmetically as easily as can simple numeric variables.

Beyond extending the standard mathematical operations and functions to include waveform processing, TEK SPS BASIC also provides special waveform processing functions. Waveforms can be integrated, differentiated, convolved, correlated, and fast Fourier transformed—all with single commands. Polar conversions can also be performed with a single command to present results in either complex form or as magnitude and phase.

With its large array size capabilities (limited only by memory in most cases), advanced signal processing, and program and instrument tasking capabilities (including error control for independent operation), TEK SPS BASIC offers all of the flexibility and power necessary to control anything from the simplest to the most sophisticated test and measurement system.

Guide for Selecting GPIB Instruments

When selecting GPIB instruments for a specific application, be sure to check several key specifications for suitability in the configuration.

First, make sure that the instrument can make the desired measurements. Next, determine that the interface functions are compatible with the proposed usage and with other instruments in the GPIB configuration. The following items should be used as a checklist with your Sales Engineer when considering instruments to be used in GPIB configurations:

1. Is the instrument intended for interactive measurement analysis or automated measurement; i.e., are all necessary instrument functions remotely programmable, or will an operator be available to adjust settings?
2. Does the instrument's GPIB interface have the necessary set of functions implemented at the desired level (e.g., AH1 is needed for any useful interaction)? SH1 is required for instruments supplying measurements to the controller.
3. Are diagnostics available to check out the instrument from the front panel or over the GPIB interface?
4. Does the instrument use standard codes and formats conventions for terminators, numeric formats, etc.?
5. Can the instrument's front panel setting be read from the controller and saved for later automated set up?
6. Can the front panel be "locked out" via the GPIB?

HANDSHAKE is a newsletter forum for users of Tektronix programmable instruments and systems. Published quarterly, HANDSHAKE has articles of interest concerning applications of stimulus, measurement, and analysis techniques.

SPS PROGRAMMING UPDATE is published periodically and sent to users of TEKTRONIX Signal Processing Systems. It contains information to help maintain software and firmware system components. It also contains useful programming hints and software and firmware product information.

Tektronix offers complete training in the operation and maintenance of signal acquisition systems and other Tek GPIB products. Classes are also available on Tek SPS Basic software.

| WAVEFORM ACQUISITION PRODUCTS | | | Page |
|--|--|---|------|
| 468 Option 02 | Digital storage Oscilloscope | A new portable 10 MHz oscilloscope with the accuracy and convenience of digital Storage. Designed for interactive applications. | 243 |
| 492P | Programmable Spectrum Analyzer | 50 kHz to 220 GHz, full programmability, GPIB interface capability, waveform transfer, internal processing. Designed for interactive and automated applications. | 122 |
| 496P | Programmable Spectrum Analyzer | 1 kHz to 1.8 GHz, full programmability, GPIB interface capability, waveform transfer, internal processing. Designed for interactive and automated applications. | 120 |
| *7912AD | Programmable Digitizer | Digitizes waveforms as high as 1 GHz to as low as 10 kHz, and stores data indefinitely in 4096 word memory. Designed for interactive and automated applications. | 181 |
| *7612D | Programmable Digitizer | 2-channel, 8 bit, 200 MHz sample rate with selectable record length and variable sample rates within records. Designed for interactive and automated applications. | 179 |
| 5223 Option 10 | Digitizing 10 MHz Oscilloscope | Capture and store single-shot data up to 100 kHz, unattended. Expand or reposition stored data. Simultaneously display stored and real-time signals. Designed for interactive applications. | 208 |
| *7854 | Digital Storage and Waveform Processing Oscilloscope | 400 MHz Plug-In Oscilloscope with optional memory, programmable measurement routines, high performance. Designed for interactive applications. | 177 |
| LOGIC ANALYZERS | | | |
| DAS 9109 Option 02 and DAS 9119 | Logic Analyzer | A General Purpose, configurable and user upgradable logic analysis system allowing sampling speeds to 660 MHz, acquisition data widths to 104 channels, 25 MHz pattern stimulation, up to 80 separate points, local tape storage, or full remote programmability. | 47 |
| GENERAL PURPOSE INSTRUMENTS | | | |
| DC 5009 | Programmable Universal Counter/Timer | Frequency and period measurements to 135 MHz using the powerful reciprocal counting technique. | 258 |
| DC 5010 | Programmable Universal Counter/Timer | Reciprocal frequency, period, ratio, and events B during A measurements to 350 MHz. | 260 |
| PS 5010 | Programmable Triple Power Supply | Three defined modes, voltage regulated, current limited and unregulated for each of its three supplies (0 to minus 32 V, 0 to plus 32 V, and plus 4.5 to 5.5 V). | 265 |
| FG 5010 | Programmable Function Generator | Phase-lock mode automatically scans and locks to any supplied input signal between 20 Hz and 20 MHz. | 274 |
| CG 551AP | Programmable Calibration Generator | Computerized System for Calibration and verification of major oscilloscope parameters. | 280 |
| MI 5010 | Multifunction Interface | Has its own intelligence which may be programmed to perform a task or conduct a sequence of events. | 290 |
| SI 5010 | RF Scanner | Two-wide TM 5000 plug-in capable of scanning and switching 16 different signal channels, or a combination of signal channels under program control. | 291 |
| SYSTEM CONTROLLERS | | | |
| 4041 | System Controller | Optimized as an instrument controller. Configurable for production lines or research labs, and for the occasional programmer or sophisticated programming team. Easy-to-use BASIC language with extensions. Up to 160k byte memory. | 292 |
| 4051 | Desktop Computer System | Powerful, easy-to-use desktop computing with graphics and extended BASIC. | 80 |
| *4052 | Desktop Computer System | High performance, personally manageable desktop computing with graphics and extended BASIC. | 80 |
| 4054 | Desktop Computer System | 19 inch screen desktop computing system with enhanced graphics and powerful BASIC. | 79 |
| PERIPHERALS FOR IEEE-488 SYSTEMS | | | |
| 4662 | Interactive Digital Plotter | Compatible in all RS-232C ASCII and GPIB environments; and with PLOT 10 and PLOT 50 Graphic Software. | 86 |
| 4663 | Digital Plotter Interactive | C size. 420 mm x 594 mm (17 in x 22 in) | 87 |
| 4924 | File Manager | Low cost mass storage, compatible with 4050 Series Desktop Computer Systems and the 4041 System Controller. | 92 |

*See pages 143-147 for Tektronix configured systems using these products.

POWER SOURCE CONSIDERATIONS

In general, instruments are factory wired for the nominal voltage of the country of manufacture. Most Tektronix instruments provide wide-range regulated supplies, or quick change line-voltage selectors for convenient selection of line-voltage operating ranges. Transformer taps in other instruments can be changed to accommodate specific line-voltage operating ranges or can be factory wired for a specific range if specified on the purchase order.

Many Tektronix instruments are designed to operate from a power source that will not apply more than 250 Volts RMS between the supply conductors or between either supply conductor and ground.

Many Tektronix instruments can be fitted with one of the power cord/plug options listed below and wired for the voltage as indicated, if specified on the purchase order.

| | | |
|----------------|-----------|-----------|
| North American | 120 V/15A | Standard |
| Universal Euro | 220 V/16A | Option A1 |
| United Kingdom | 240 V/13A | Option A2 |
| Australian | 240 V/10A | Option A3 |
| North American | 240 V/15A | Option A4 |
| Switzerland | 220 V/10A | Option A5 |

During the life of this catalog the power cord/plug options will be made available on additional instruments. Refer to the individual product ordering information for those products offering these options as of publication date.

Except for some double-insulated instruments, most Tektronix instruments are equipped with either a three-conductor attached power cord or a three-terminal power-cord receptacle. The third wire or terminal is connected directly to the instrument chassis to protect operating personnel.

Power-cord coding follows one of the two following schemes:

| | Scheme 1 | Scheme 2 |
|-----------------------|--------------|--------------|
| Line | Black | Brown |
| Neutral | White | Light blue |
| Ground (safety earth) | Green-yellow | Green-yellow |



**Standard
North American
120 V/15A**

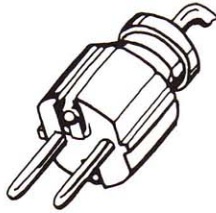

**Option A1
Universal Euro
220 V/16A**

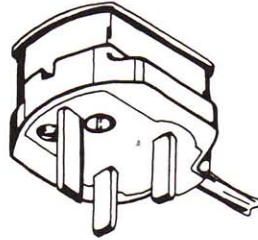

**Option A2
UK
240 V/13A**

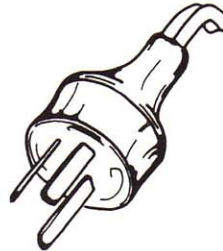

**Option A3
Australian
240 V/10A**



**Option A4
North American
240 V/15A**

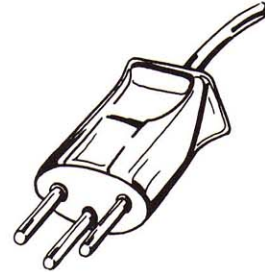

**Option A5
Switzerland
220 V/10A**

ENVIRONMENTAL CHARACTERISTICS

The environmental characteristics listed in instrument specifications may include some or all of the following: temperature, altitude, humidity, vibration, shock, and electromagnetic compatibility (emc previously rfi or emi).

The specifications for humidity, vibration, shock, and transportation are intended to be beyond what can be expected in use, and operation at these extremes may cause minor physical dete-

rioration. Such operation, however, should not cause electrical performance to deteriorate outside specifications.

The specifications for temperature and altitude are such that continual use at the limits will not cause significant short-term deterioration. Naturally, higher temperature operation can be expected to reduce long term reliability and should be avoided if possible. The emc test is completely nondestructive.

Sample production instruments are tested periodically as part of a continual quality-control process. Complete tests on every production instrument are undesirable as well as uneconomical.

For more specific information on the environmental characteristics and how they apply to given instruments, please refer to the page covering that instrument.

DESIGN AUTOMATION DIVISION

One of the fastest growing enterprises at Tektronix is the Design Automation Division. It operates at the forefront of digital technology, offering a full line of tools to support the design of microprocessor-based systems. Jim Fischer, division sales manager, represents the division's commitment to anticipate the long-range customer needs and changes in technology. In customer support and product development, the Design Automation Division is committed to providing flexible solutions for a future of change.



MICROCOMPUTER DEVELOPMENT PRODUCTS

CONTENTS

| | |
|---|----|
| Microcomputer Development Labs | |
| 8540 | 13 |
| 8560 | 14 |
| 8550 | 16 |
| Emulator Processor and Prototype Control Probe Support Packages | 18 |
| Trigger Trace Analyzer | 21 |
| High Level Language | 22 |
| System Peripherals and Workshops | 23 |
| Matrix and Ordering Information | 24 |

MDL Now Supports

| | | |
|---------------|--------------|----------------|
| 8088 | 8022 | 3870 |
| 8086 | 8041A | 3872 |
| 8085A | 68000 | 3874 |
| 8080A | 6800 | 3876 |
| 8048 | 6801 | Z-80A |
| 8049 | 6802 | Z8001 |
| 8035 | 6803 | Z8002 |
| 8039 | 6808 | TMS9900 |
| 8021-6 | F8 | SBP9900 |
| | | 1802 |

... with more to come

Tektronix Microcomputer Development Products offer the broadest range of quality multiple micro-processor support available today. Tektronix won't lock you into one microprocessor family or vendor. Plus, every Tektronix MDL is backed with over 30 years of design experience. We test our Development Labs thoroughly to ensure performance and reliability. Each one provides complete development capability and the Tektronix commitment that guarantees you'll keep abreast of the fast paced micro-processor technology.

Call your local specialist today to find out more about the Tektronix 8550 MDL Systems.





NEW

8540

Multiple Microprocessor Support

Real-Time Emulation

Trigger Trace Analysis

8560 Compatible

The TEKTRONIX 8540 Integration Unit provides complete coverage of the hardware/software integration process during microcomputer design. By using interchangeable emulator modules, the 8540 allows maximum flexibility in chip support, with more support constantly being added as new chips gain acceptance in the microcomputer industry. Current support includes: Z-80A, 8085A, Z8001, Z8002, 6809, 8035, 8039, 8041A, 8048, 8049, 8086, 8088, 68000, 6800, 6802, 8080. The 8540 is designed for use with the TEKTRONIX 8560 Multi-user Software Development Unit or a general host computing system. In 8560 configurations the 8540 connects to the system via a built-in high-speed interface (HSI). For general host environments, the Option 01 Communications Interface is available. It will readily interface the 8540 to host computer through a standard RS-232C ASCII communications port.

All major interface parameters are software selectable through the 8540's operating system, and a complete communications package is included to cover individual situations.

Once the prototype microcomputer software has been refined into executable object code by the host computer, or 8560, it is ready for transfer to the 8540 to begin debugging. At the same time, a symbol table may be transferred so program tables can be used instead of address data to reference key locations in prototype memory. The 8540 can provide up to 128k bytes (64k words) of program memory that can be used in place of prototype memory, and with the optional Memory Allocation Controller, it can be distributed throughout the prototypes address space, up to 64 megabytes—a valuable asset when working with large programs.

Three Modes of Real-time Emulation. To achieve hardware/software integration, the 8540 employs a technique called real-time emulation, which uses an emulator processor identical in function to the one targeted for the prototype. Under control of the 8540's debug firmware, the emulator processor can execute prototype code at the full specified operating speed of the target processor, with no wait states added or clock pulses stretched.

Emulation takes place in three progressive modes that allow gradual introduction of hardware and software. During the first mode, the emulator processor uses the 8540 exclusively as the source of program memory, I/O and clock, allowing debugging to begin even before the prototype hardware is available. During the second mode, the emulator processor is connected via probe to the vacant processor socket on the

prototype, which now handles all clock and I/O functions. Code can now be mapped over to the prototype in manageable blocks from the 8540's program memory. During the third and final mode, all code resides in the prototype, as well as the clock and I/O functions. Only the emulator control probe remains in place to provide debugging control during program execution.

During all three modes of real-time emulation, prototype code execution takes place under the control of the 8540's powerful debug software. For easy reference, key breakpoints may be entered using mnemonic labels instead of numeric addresses. At each breakpoint, the status of all the processor's key registers is displayed. It is also possible to display the processor's register status and associated code execution on a cycle-by-cycle basis. All registers and memory locations can be modified to observe the consequent effect on program flow.

Trigger Trace Analyzer. Many debugging situations demand detailed observation of real-time code execution on the prototype bus, and its effect on other key points in the hardware. A modular option to the 8540 is the Trigger Trace Analyzer, which allows real-time data acquisition from both 8-bit and 16-bit prototype systems. Its trace memory can capture up to 255 bus transactions of plus logic states from eight hardware points selected by the user. Included are four separate trigger channels, each with a word recognizer that monitors up to 16 data bits, 24 address bits, 14 processor-dependent control bits and 8 external probe bits. Each trigger channel also has a 16-bit counter for timing and counting. These four channels may be used either independently or interactively to construct powerful data acquisition triggers. Either single or multiple breakpoints can be set, with the option to halt or continue program execution after they occur.

PROM Programmer. Many designs require that the prototype code be burned into a PROM, which is then installed aboard the prototype and used as a program memory source during debugging. The 8540 includes an optional PROM Programmer, which allows code resident in the 8540's program memory to be burned into a PROM. Individual card modules are supplied that adapt the PROM Programmer to any PROM family the designer may be working with.

8540/Host Communications Package (Option 01). This package provides all the features necessary to interface the 8540 with nearly any host computer that supports RS-232, ASCII terminal communications. The 8540 has built-in software that allows the user to modify major communication parameters, such as parity, echo, turn-around delay. Data rates from 110 to 9600 baud can also be selected. The package also makes allowance for data set as well as "in line" interface configurations between the 8540 and a host computer.



NEW

8560

Multi-Chip Design Support For Up to 8 Users

TNIX Operating System

The TEKTRONIX 8560 MDL is a multi-user development system that when used in conjunction with an 8540 Integration Unit covers the entire microcomputer design process, from software development through hardware/software integration. At the same time, it allows maximum design flexibility by supporting a broad range of chips at both the 8-bit and 16-bit levels. The 8560's multi-user capability offers numerous advantages, such as lower cost per user, shared software and hardware resources, unified project management and enhanced security.

System Architecture. At the heart of the 8560 system is a powerful 16-bit CPU, backed by an I/O processor for every four users and 64k words of RAM (expandable to 128k words). This CPU uses a time-shared operating system to supervise up to eight work stations plus mass storage and printing. Workstation terminals can be any standard RS-232 terminal, such as the TEKTRONIX CT8500. Hardware/software integration stations use the TEKTRONIX 8540 Integration Unit, which allows for several different terminal configurations. In this manner, a terminal used for software development can also double as a control terminal for hardware/software integration.

For mass storage, the 8560 uses an 8 inch 35.6 megabyte Winchester hard disc unit, and a 1 megabyte flexible disc unit. Storage capacity can be expanded by adding additional 35.6 megabyte hard disc units. The 8560 also will support two spooling line printers.

UNIX Based Operating System. The 8560 uses a powerful operating system called TNIX, which is derived from the UNIX operating system, created by Bell Laboratories and widely used throughout the computer world. TNIX uses timesharing to apportion system resources among up to eight workstations plus system utilities. Also used is a hierarchical filing system that allows both files and directories to be logically grouped and easily accessed. Each file carries a date/time attribute to quickly verify which version the user is accessing.

Users may also access each other's files if no restriction has been placed on them, thus allowing files to be easily grouped according to current project needs. Each file can be assigned read, write or execute protection that can be applied to the owner, the owner's project group or system users at large. Besides providing security, this protection feature allows "work copies" of files to stay private until they are completed and ready for release to the project. For additional security, TNIX employs a user password system.

TNIX includes several powerful methods of manipulating system commands. One is pipelining, which allows the output of one program to provide the input for another. In this manner, the user may create strings of commands that quickly accomplish complex tasks without user intervention. Command files can also be created that allow commands to be controlled through structures such as case statements and conditional branching. It is also possible to substitute parameters within command statements when creating command files.

Several features are included which optimize the user's time. One is multi-tasking, which allows one user task, such as a compilation, to run in the background, while another, such as editing a source file, is being entered at the terminal. TNIX includes a special utility program that automates much of the work necessary to combine separate code modules into a single program. Another utility is provided that allows system users to communicate directly with each other, or through "electronic mail", which is a valuable aid when workstations are at separate physical locations.

Software Development Tools. As a series of optional packages, Tektronix will offer Assemblers and Pascal compilers for many of the major chips in current use among microcomputer designers. All Assemblers include macro capability for the creation of high level-type constructs. Assembled code is relocatable so that object modules can be moved throughout the available memory space. And to support the large address space capability of many 16-bit processors, a 32-bit address range is provided, which gives over four billion bytes of addressable memory. Through a conditional assembly feature, one source file can be instructed to generate multiple versions in the form of different object modules. Also, external source files can be pulled into the program during assembly. Strings can be manipulated to accomplish tasks such as basing a conditional assembly on a string comparison.

The 8560's Pascal compilers are all compatible with the ISO standard for increased portability. All have a common set of features to enhance the power of Pascal in microcomputer applications. Bit manipulation is included to allow access to prototype hardware logic. Variables can be assigned to specific memory addresses, allowing memory mapped I/O. Re-entrant code can be used in applications requiring interrupt handling. Literals, constants and instructions can be separated from variables so they can be installed in ROM. During compilation, external source files can be pulled into the program. Also individual modules can be compiled separately for simplified debugging.

Other software tools include both language-directed and CRT-oriented editors, and a text processing package for improved documentation.

Hardware/Software Integration. To handle hardware/software integration tasks, the 8560 uses the TEKTRONIX 8540 Integration unit as a peripheral work station. Once code targeted for the prototype has been assembled or compiled into executable object modules, it can be downloaded to the 8540's program memory via high speed interface. The code can now be gradually introduced to the hardware using real-time emulation, a powerful debugging method that employs a processor identical in function to the one targeted for the prototype.

Real-time emulation takes place in three progressive modes, all under the control of the 8540's debug software. During the first mode, all code is executed out of the 8540's program memory, with I/O simulated by software insertions and clock signal supplied by the 8540. In this manner, prototype software debugging can begin even before the hardware becomes available. During the second mode, I/O and clock functions are transferred to the prototype, and code can be mapped over to the prototype memory in manageable blocks. A control probe connects the emulator processor to the vacant processor socket on the prototype board. During the final mode, all code is installed in the prototype memory, as well as clock and I/O functions. Through the control probe, the 8540 can now exercise prototype hardware in the same manner that it will function when standing alone.

During all three modes of emulation, the 8540's powerful debug software can be applied. Breakpoints can be set using mnemonic symbols for key program locations. The status of processor registers can be examined on a cycle-by-cycle basis. All registers and memory locations can be examined and modified. And for detailed analysis of real-time execution on the prototype bus and selected hardware points, an optional Trigger Trace Analyzer is available with four powerful trigger channels that allow highly selective data acquisition.

8550

Multiple Microprocessor Support

In-Circuit Emulation

Real-Time Prototype Analysis

The TEKTRONIX 8550 Microcomputer Development Lab is a versatile software development and hardware/software integration system for microcomputer-based product design. The system supports many 8- and 16-bit microprocessors, allowing the user to configure the 8550 for a wide variety of design types.

The 8550 Development Lab offers resources for editing facilities to support both assembly-level and high-level languages, as well as linking capabilities. The optional Advanced CRT-Oriented Editor speeds the task of program entry and editing. With the appropriate assembler and emulator options for the target microprocessor, the user can execute software in the 8550 for full program debugging.

The Lab also offers complete in-circuit emulation and hardware testing capabilities. With the appropriate prototype control probe for the target microprocessor, the user can transfer control from the 8550 to the prototype block by block, debugging at every stage. The Trigger Trace Analyzer option provides an invaluable tool for verifying and correcting execution of the program in real time.

The basic 8550 system consists of two major components, the 8301 Microprocessor Development Unit and 8501 Data Management Unit. The Microprocessor Development Unit houses the operating system software, DOS/50; 32k bytes of program memory; language processor; emulator controller; and hardware options such as emulator processors and prototype control probes for selected microprocessors, Optional 32k, 64k, or 128k static RAM modules, the Trigger Trace Analyzer, Real Time Prototype Analyzer, and the PROM programmer. Optional system software includes assemblers for all supported microprocessors, Pascal and MDL/μ compilers for several supported microprocessors, and the Advanced CRT-Oriented Editor.

The Data Management Unit handles files and auxiliary I/O for DOS/50 and manages the movement of user files between its dual-sided, double-density flexible discs and the Microprocessor Development Unit. Disc memory capacity is 2 megabytes.

Multiple Microprocessor Support

A key feature of the 8550 is its ability to support many microprocessor chips, including the 8086, 8088, 8085A, 8080A, 8048, 8049, 8035, 8039, 8039-6, 8021, 8041A, 8022, 68000, 6800, 6802, 6805, 6808, 6809, F8, 3870, 3872, 3874, 3876, Z8001, Z8002, Z-80A, TMS9900, SBP9900, 1802 and 6500/1.

Program Development

Under the supervision of the operating system software, the Microcomputer Development Lab aids the designer in all phases of program development and debugging.

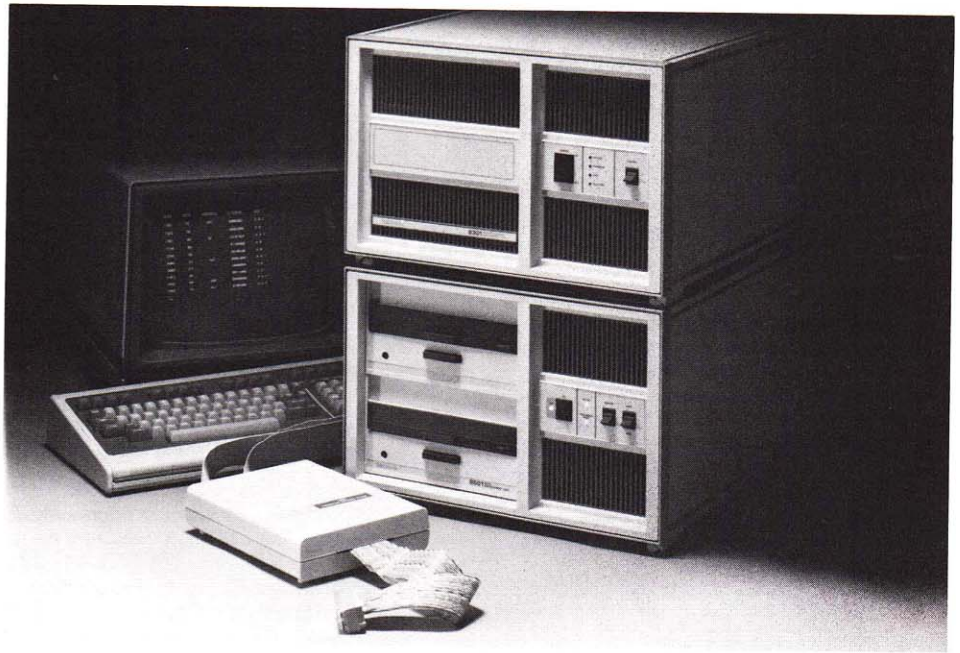

DOS 50 supervises the following tasks:

- General input and output
- File creation and maintenance.
- Program assembly and compilation.
- Program execution, monitoring, and symbolic debugging

Program entry and editing is accomplished via the standard line-oriented editor or the optional Advanced CRT-Oriented Editor, which allows both line- and screen-oriented editing. Complete symbolic debugging with versatile output formats speeds the software debugging process.

Data management is simplified through a tree-like structure format, which allows the user to specify one main system directory, one root directory for each disc, and any number of sub-directories under the root directory. Data files may be created and entered directly into the root directory. As files are accumulated, the user may organize them into specific groups, each under its own specific directory. This allows the user to create directories within directories to any level of nesting needed.

The assembler processor, with the appropriate disc inserted in the flexible disc drive, performs program assembly functions for each microprocessor supported by the 8550.

The powerful macro capability allows the designer to access frequently used sets of code by referencing the macro by name. The linker, working with the relocating features of the Assembler, links and locates multiple code segments into a complete executable program. Additionally, the conditional assembler capability of the 8550 allows the designer to customize the final program by testing conditions to determine which of certain code segments are to be assembled into the final program. Code management is further enhanced by the Assembler's versatile string handling capability. Extensive English language diagnostics of the 8550 provide easy to understand error messages and locate the line in which

the error has occurred. When assembly is completed, the assembled object code is stored on disc in a newly created binary format file.

Three Emulation Modes

After an error-free assembly listing has been obtained, the resulting object code may be executed in system emulation mode 0 on the optional emulator processor. The emulator processor is identical to the microprocessor that will finally be installed in the user's prototype. Execution is performed under control of the debug system; during execution, program steps can be traced, software breakpoints can be set, and memory can be examined and changed as required. Should an error be discovered, that portion of the program can be corrected at the source level using the text editor. It can then be reassembled and executed again. This procedure continues until the program is correct.

After the software has been debugged, it may be exercised on the prototype circuitry in the partial emulation mode (mode 1). During partial emulation, control may be released from the 8550 to the prototype in stages. The developmental software runs using 8550 memory space and prototype I/O and clock. The 8550 memory mapping feature allows memory to be gradually mapped over to the prototype in blocks. Throughout partial emulation, the user has access to prototype circuitry through the debugging system, which enables him, as before, to trace, set break-points, examine and change memory and register contents.

In full emulation (mode 2) the program is run on the prototype, but program execution is still under the complete control of the debug system. All I/O and timing functions are directed by the prototype; all memory has been mapped over to the prototype; and only the prototype control probe is still in place, emulating the target microprocessor. Although the prototype is effectively free-standing, then, the user may still direct program activity from the 8550.

8550 Parts and Functions

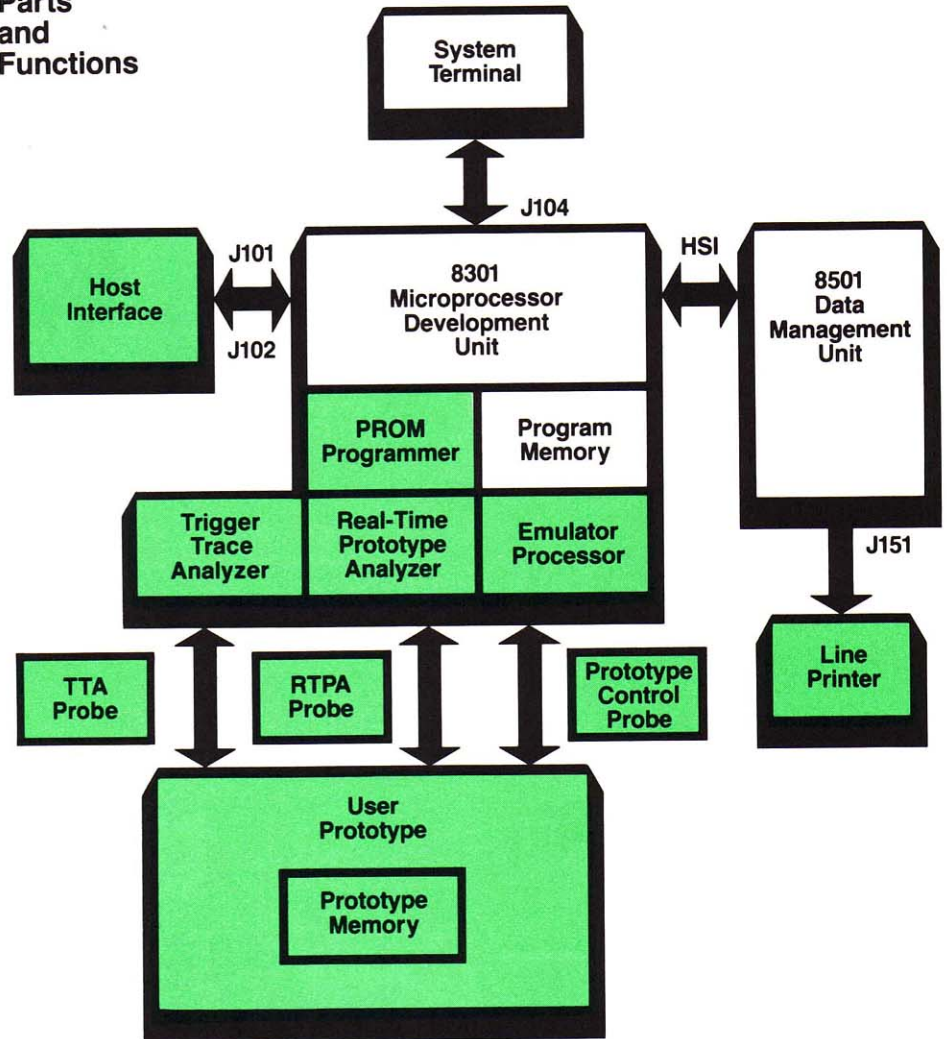

8550 CHARACTERISTICS

8301 MICROPROCESSOR DEVELOPMENT UNIT

| Dimension | mm | in |
|-----------|-----|----|
| Height | 280 | 11 |
| Width | 430 | 17 |
| Length | 585 | 23 |
| Weight | kg | lb |
| Net | 27 | 60 |

ENVIRONMENTAL

| | |
|-----------------------|------------------------------------|
| Operating Temperature | 32°F to 122°F (0°C to 50°C) |
| Humidity | 90% @ 86°F to 140°F (30°C to 60°C) |
| Altitude | |
| Operating | 4,500 m (0 to 15,000 ft) |
| Storage | 15,000 m (0 to 50,000 ft) |

POWER REQUIREMENTS

115 V ac (90 V ac-132 V ac) @ 48 to 66 Hz.
230 V ac (180 V ac-250 V) @ 48 to 66 Hz.

Outputs

5.2 V dc +1%/-2% @ 35.0 A
+12 V dc +0/-5% @ 1.7 A
-12 V dc +0/-5% @ 1.7 A

8501 DATA MANAGEMENT UNIT

| Dimension | mm | in |
|-----------|-----|------|
| Height | 267 | 10.5 |
| Width | 424 | 16.8 |
| Length | 597 | 23.5 |
| Weight | kg | lb |
| Net | 25 | 55 |

ENVIRONMENTAL

| | |
|-----------------------|---|
| Operating Temperature | 50°F to 104°F (10°C to 40°C) |
| Humidity | 20% to 80% relative noncondensing |
| Altitude | |
| Operating | 0 to 2500 m (8,000 ft) Derate max operating temp by 1°C for each 300 m above 2400 m |
| Storage | 0 to 15,000 m (50,000 ft) |

POWER REQUIREMENTS

115 V ac (90-127 V RMS) @ 50 Hz ±1% or 60 Hz ±1%.
230 V ac (180-250 V RMS) @ 50 Hz ±1% or 60 Hz ±1%.

Outputs

24 V dc ±5% @ 2 A
12 V dc ±3% @ 4 A
-12 V dc ±5% @ 540 mA
5 V dc ±5% @ 20 A
15 V dc ±10% @ 20 mA

Output Ripple

| | |
|----------|--------------|
| 24 V dc | 100 mV (p-p) |
| ±12 V dc | 120 mV (p-p) |
| 15 V dc | 50 mV (p-p) |
| 15 V dc | 100 mV (p-p) |

Overload Protection

Automatic current limit foldback.

FLEX DISC CHARACTERISTICS

Encoding — IBM compatible single or double density. Format must qualify as follows: MFM sectors—256 bytes. FM sectors—128 bytes.

Diskette Type — Single or double sided, soft sector.

Capacity —

Double sided, double density 1,021,696 bytes.

Single sided, double density 509,184 bytes.

Single sided, single density 256,256 bytes.

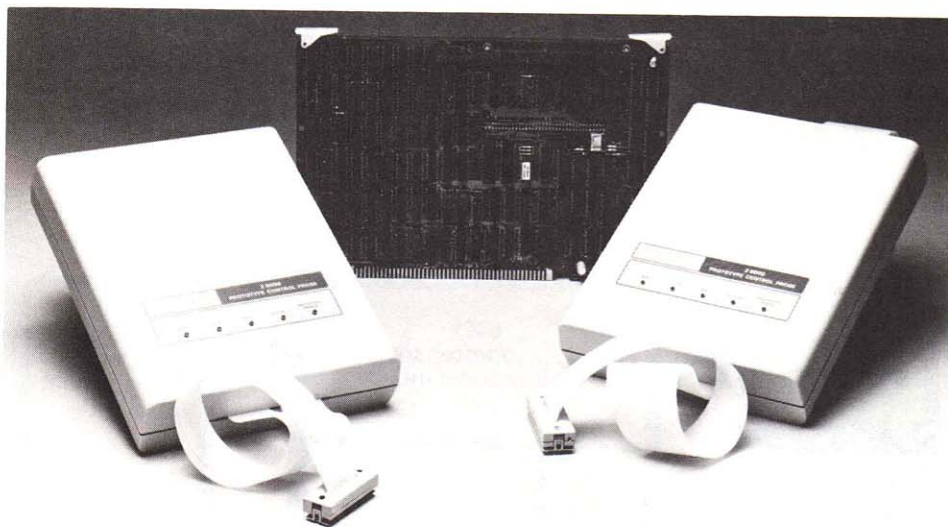

The 8550 and 8640 Microcomputer Development Labs support a wide variety of different microprocessors and microcomputers.

Emulators to support the 8550 are currently available for the Intel 8088, 8086, 8085A, 8080A, 8048, 8049, 8039, 8039-6, 8035 and 8021, Motorola 68000, 6800, 6802, and 6809, Texas Instruments TMS9900, Zilog Z-80A, Z8001 and Z8002, Fairchild F8, RCA 1802, the Mostek 3870 and 3872, and Rockwell 6500/1. Emulators to support the 8540 are currently available for the Intel 8086, 8088, 8080A, 8085A, 8048, 8049, 8039, 8039-6, 8035, and 8021, Motorola 68000, 6800, 6802, and 6809, and Zilog Z8001A, Z8002A and Z-80A.

Emulator packages for the 8550 and 8540 may be ordered as system options. These options provide the capabilities necessary to fully emulate the target microprocessor in a user's prototype system.

The emulator processor, which resides on a plug-in circuit module along with controlling logic circuitry, enables the user to execute and debug the program on a microprocessor identical to the one which will be used in the prototype, while giving him access to the full 64k bytes of Microprocessor Lab program memory.

The prototype control probe, which links the emulator processor to the prototype system, allows partial and full in-circuit emulation.

All emulation operations are controlled by the powerful Microprocessor Lab system software. The user is able to monitor program execution, set software breakpoints, examine and change memory and register contents. Debug trace information is displayed in a format unique to the microprocessor, with instruction fetches disassembled into mnemonics for easy interpretation.

8049, 8035, 8039, 8039-6, 8022, 8041A, 8048/8021 EMULATOR SUPPORT PACKAGE CHARACTERISTICS

8048, 8049, 8039, 8039-6, 8035, 8022, 8041A and 8021 are trademarks of Intel Corporation. Tektronix, Inc., does not guarantee that other vendors versions of these microcomputers will be compatible with Tektronix Microprocessor Labs.

PHYSICAL CHARACTERISTICS

Length — 1.8 m (6 ft)—of cable from the emulator processor to the interface assembly. 45.8 cm (1.5 ft)—of cable from the interface assembly to the 40-pin plug (or 28-pin plug for 8021).

Cable Configuration — 1.8 m (6 ft)—two 40 conductor ribbon cables with alternating ground and signal paths.

45.8 cm (1.5 ft)—two laminated 40 conductor cables made up of signal-ground pairs.

EMULATION INTERFACE (TYPICAL WORST CASE) DELAYS FOR THE 8048 (8021 IF DIFFERENT)

| | | tPLH (ns) Typ. Worst Case | tPHL (ns) Typ. Worst Case |
|--|---|------------------------------|------------------------------|
| ALE | | 14,20 | 14,20 |
| PSEN | | 22,32 | 22,32 |
| RD,WR | | 18,26 | 15,22 |
| PROG | | 14,20 | 14,20 |
| D80-D87*** (P00-P07) User to CPU | t ₁ —fetch cycle t ₂ —execute cycle | .90 26,38 | .90 26,38 |
| D80-D87 (P00-P07) CPU to User | t ₃ —Address Out t ₄ —Ext Data Out t ₅ —OUTL, ANL, ORL, data out | 26,38 26,38 14,20 | 26,38 26,38 14,20 |
| P10-P17 P24-P27 | | 2,2 | 2,2 |
| P20-P23 | | | |
| T0** | out/in | 11,15 | 11,15 |
| T1 | | | 102,82 |
| INT | | 21,32 | 21,32 |
| RST | 8048 (8021) | (120,212) | 69,122 |
| SS | | 22,32 | 22,32 |
| CLK | | 29,47 | 31,52 |

*INTEL 8099 chip specifications.

**for clock in to 8039 >6 MHz and memory mapped to 8550. T0 out is divided by 2.

***t'RD' = t 1.2 + t user mem access.

8041A PROTOTYPE CONTROL PROBE (Typical, worst case)

Emulation Interface Delays

| | tPLH (ns) (typ WC) | tPHL (ns) (typ WC) |
|---------|-----------------------|-----------------------|
| SYNC | 14,20 | 14,20 |
| PROG | 14,20 | 14,20 |
| T1 | | 27,39 |
| P10-P17 | 2,2 | 2,2 |
| T0 | 29,45 | 22,34 |

| Symbol | Parameter | Min | Max | Units |
|--------|-------------------------|-----|-----|-------|
| tACC | DACK to WR or RD | 54 | | ns |
| tCAC | RD or WR to DACK | 71 | | ns |
| tACD | DACK to data valid | | 225 | ns |
| tCRQ | RD or WR to DRQ cleared | | 200 | ns |
| tAW | CS, AO Setup to WR | 0 | | ns |
| tWA | CS, AO Hold after WR | 24 | | ns |
| tWW | WR Pulse Width | 250 | | ns |
| tDW | Data Setup to WR | 150 | | ns |
| tWD | Data Hold after WR | 70 | | ns |

8022 PROTOTYPE CONTROL PROBE

8022 Timing Characteristics With Emulation Interface Delays

| | tPLH (ns) typ. Worst Case | tPHL (ns) typ. Worst Case |
|----------|---|----------------------------------|
| ALE | 24,34 | 32,46 |
| P00-P07 | 54,87 | 57,91 |
| P10-P17 | 1.3 μs | 1.3 μs |
| P10-P17 | t1—CPU to USER t2—USER to CPU | 2,2 2,2 |
| P20-P23 | for OUTL inst: data valid before ALE after the next instruction fetch. t3—MOVD P2, A t4—MOVD A, P2 IN A, P2 | 13,18 17,24 13,18 17,24 |
| PROG | 13,18 | 17,24 |
| T0 | 17,24 | 17,24 |
| T1 | 102,182 | 102,182 |
| ANO, AN1 | 336,444 | 336,444 |
| XTAL1 | 21,33 | 29,45 |

*Inputs must be present until read by an input instruction (Intel Specification).

8080A EMULATOR SUPPORT PACKAGE CHARACTERISTICS

8080 and 8080A refer to microprocessors manufactured by Intel Corporation. Tektronix, Inc., does not guarantee that other vendors' versions of the 8080 will be compatible with the Tektronix Microprocessor Labs.

PHYSICAL CHARACTERISTICS

Length — 1.8 m (6 ft)—of cable from the emulator processor to the interface assembly.

45.8 cm (1.5 ft)—of cable from the interface assembly to the 40 pin plug.

Cable Configuration — 1.8 m (6 ft)—two 40-conductor ribbon cables with alternating ground and signal paths.

45.8 cm (1.5 ft)—two twisted pair 40 conductor cables.

Termination — 1.8 m (6 ft)—interface assembly contains resistive termination and receivers for data, address, and control from the emulator processor module.

45.8 cm (1.5 ft)—not terminated.

40 pin plug—40 pin spring plate protected plug. When used with a zero insertion force socket, an included 40 pin low profile DIP socket must be used between the zero insertion force socket and the 40 pin probe plug.

TIMING CHARACTERISTICS Emulation Interface Delays*

| To 8080A from Interface Assembly | Typ | Max (in ns) |
|-------------------------------------|-----|-------------|
| O1 | 44 | 60 |
| O2 | 44 | 60 |
| HOLD | 44 | 67 |
| RESET | 44 | 67 |
| RDY** | 35 | 40 |
| INT | 63 | 104 |
| DATA | 44 | 53 |

| From 8080A to Interface Assembly | Typ | Max (in ns) |
|-------------------------------------|-----|-------------|
| HOLDA*** | 39 | 55 |
| SYNC | 37 | 45 |
| WAIT | 37 | 45 |
| WR | 37 | 45 |
| DBIN | 37 | 45 |
| INTE | 39 | 55 |
| ADDRESS | 27 | 35 |
| DATA | 50 | 63 |

*Assumes 6 ft of cable at 1.5 ns/ft.

**RDY is ignored unless user memory or I/O is accessed in control mode 2 or special mode.

***The equation for HOLDA to tristate timing is as follows:
HOLDA * DBIN = FLOAT. Tristate of data and address follows the trailing edges of DBIN or WR by ≈ 20 ns.

8085A EMULATOR SUPPORT CHARACTERISTICS

8085 and 8085A refer to microprocessors manufactured by Intel Corporation. Tektronix, Inc. does not guarantee that other vendors' versions of the 8085 will be compatible with the Tektronix Microprocessor Labs.

PHYSICAL CHARACTERISTICS

Length — 1.8 m (6 ft)—of cable from the emulator processor to the interface assembly.

30 cm (1 ft)—of cable from the interface assembly to the 40 pin plug.

Cable Configuration

1.8 m — (6 ft)—two 40-conductor ribbon cables with chassis ground plane and signal paths.

30 cm (1 ft)—two 40-conductor twisted pair cables.

Termination — 1.8 m (6 ft)—interface assembly contains receivers for data, address, and control from the 8085 emulator processor module.

30 cm (1 ft)—not terminated.

AC CHARACTERISTICS

| Emulation Clock | |
|---|--|
| Mode 1 or Mode 2 (user's clock), with 8085A Prototype Control Probe | 6.25 MHz max; crystal, RC timing network or TTL input to X1. |
| Mode 0 (system clock) | 6.25 MHz \pm 0.01% |

6800/6802 EMULATOR SUPPORT PACKAGE CHARACTERISTICS

6800 and 6802 refer to microprocessors manufactured by Motorola Corporation. Tektronix, Inc. does not guarantee that other vendors' versions of the 6800 or 6802 will be compatible with the Tektronix Microprocessor Labs.

PHYSICAL CHARACTERISTICS

Length — 1.8 m (6 ft)—of cable from the emulator processor to the interface assembly.

30 cm (1 ft)—of cable from the interface assembly to the 40 pin plug.

Cable Configuration — 1.8 m (6 ft)—two 40-conductor ribbon cables with alternating ground and signal paths.

30 cm (1 ft)—two twisted pair 40 conductor cables made up of signal/ground pairs.

6800 PROTOTYPE CONTROL PROBE Read/Write Timing (in ns)

| Characteristic | Symbol | Min | Typ | Max |
|--|--------|------|-----|-----|
| Peripheral Read Access Time | DTACC | | | 506 |
| Address Setup Time | DTDA | | | 350 |
| R/W Setup Time | DR/WSU | | | 375 |
| VMA Setup Time | DEVMA | | | 365 |
| Data Setup Time (Read) | DTDDR | 119 | | |
| Data Delay Time (Write) (relative to 01 \uparrow) | TDDW | | | 513 |
| Delay for DBE Rising Edge (relative to 01 \uparrow) | DDBER | | | 444 |
| Input Data Hold Time | DHRD | 29 | | |
| Output Data Hold Time (after 01 \uparrow) | DTDWH | 40** | 10 | |
| Output Data Hold Time (after DBE \downarrow) | DTDWH | 20 | | |
| Address Hold Time | DADH | 65 | | |
| VMA Hold Time | DVMAH | 68 | | |
| R/W Hold Time | DR/WH | 61 | | |

6802 PROTOTYPE CONTROL PROBE Read/Write Timing (in ns)

| Characteristic | Symbol | Min | Typ | Max |
|-----------------------------|--------|------|-----|-----|
| Peripheral Read Access Time | DTACC | | | 408 |
| Address Setup Time | DTDA | | | 367 |
| VMA Setup Time | DEVMA | | | 365 |
| R/W Setup Time | DR/WSU | | | 392 |
| Data Setup Time (Read) | DTDDR | 127 | | |
| Data Delay Time (Write) | TDDW | | | 527 |
| Input Data Hold Time | DHRD | 40** | 10 | |
| Output Data Hold Time | DTDWH | 39 | | |
| Address Hold Time | DADH | 63 | | |
| VMA Hold Time | DVMAH | 66 | | |
| R/W Hold Time | DR/WH | 70 | | |

**Although data should remain valid at least 40 ns after Enable, typically 10 ns will be sufficient.

6809 EMULATOR SUPPORT PACKAGE CHARACTERISTICS

6809, 68A09 and 68B09 refer to microprocessors manufactured by Motorola, Inc. Tektronix does not guarantee that other vendors' versions will be compatible with the Tektronix Microcomputer Labs.

PHYSICAL CHARACTERISTICS

Length — 1.8 m (6 ft)—of cable from the Emulator Processor to the interface assembly.

30 cm (1 ft)—of cable from the interface assembly to the 40-pin plug.

Cable Configuration — 1.8 m (6 ft)—two 40-conductor ribbon cables with chassis ground plane and signal paths.

30 cm (1 ft)—two 22-conductor teflon cables with alternating grounds.

Termination — 1.8 m (6 ft)—interface assembly contains receivers for data, address, and control from the 68XX emulator processor module.

30 cm (1 ft)—probe assembly contains an oscillator circuit to drive and buffer the 6809 clock input pins. Input lines are not terminated. All output or bidirectional lines are series terminated with 100 Ω .

Z-80A EMULATOR SUPPORT PACKAGE CHARACTERISTICS

Z-80 and Z-80A refer to microprocessors manufactured by Zilog Corporation. Tektronix, Inc. does not guarantee that other vendor's versions of the Z-80 will be compatible with the Tektronix Microprocessor Labs.

PHYSICAL CHARACTERISTICS

Length — 1.8 m (6 ft)—of cable from the emulator processor to the interface assembly.

30 cm (1 ft)—of cable from the interface assembly to the 40 pin plug.

Cable Configuration — 1.8 m (6 ft)—2 40-conductor ribbon cables with chassis ground plane and signal paths.

30 cm (1 ft)—two 40-conductor twisted pair cables.

Termination — 1.8 m (6 ft)—interface assembly contains receivers for data, address and control from the Z-80 Emulator Processor module.

30 cm (1 ft)—not terminated.

TIMING CHARACTERISTICS

The Z-80A Emulator Processor was designed to match the ac characteristics of the Z-80A and Z-80 Microprocessors.

Z8001/Z8002 Emulator Support Package Characteristics

Z8001, Z8002, Z8001A, and Z8002A refer to microprocessors manufactured by Zilog Corp and AMD Inc. Tektronix does not guarantee that other vendors' versions will be compatible with the Tektronix Microcomputer Labs.

PHYSICAL CHARACTERISTICS

Length — 1.8 m (6 ft) of cable from the Emulator Processor to the interface assembly; 45 cm (1.5 ft) of cable from the interface assembly to the 40- or 48-pin plug.

Cable Configuration — 1.8 m (6 ft)—two transmission line cables, each 40 signal lines and 80 signal return lines terminated to 40-pin connector.

For Z8001 — 45 cm (1.5 ft)—two transmission line cables, each 40 signal lines and 80 signal return lines terminated to 40-pin connector.

For Z8002 — 45 cm (1.5 ft)—two transmission line cables, each 25 signal lines and 52 signal return lines terminated to 26-pin connector.

Termination — 1.8 m (6 ft)—interface assembly contains receivers for data, address, and control from the Z8000 emulator processor module.

30 cm (1 ft)—address and data lines terminated with Schottky diodes. Control lines driven by pod are source terminated. Input line to the emulator are received with PNP inputs. Clock, Wait, Stop, and Reset inputs are buffered in the probe to maintain signal quality.

TMS9900 EMULATOR SUPPORT PACKAGE CHARACTERISTICS

TMS9900 refers to microprocessors manufactured by Texas Instruments Corporation. Tektronix, Inc. does not guarantee that other vendors versions of the TMS9900 will be compatible with the TEKTRONIX Microprocessor Labs.

PHYSICAL CHARACTERISTICS

Length — 1.8 m (6 ft)—of cable from the emulator processor to the interface assembly.

24.2 cm (9.5 in)—of cable from the interface assembly to the 64 pin plug.

Cable Configuration — 1.8 m (6 ft)—two 40-conductor ribbon cables with chassis ground plane and signal paths.

24.2 cm (9.5 in)—two 32-conductor twisted pair cables.

Termination — 1.8 m (6 ft)—the interface assembly contains receivers for data, address, and control from the TMS9900 emulator processor module.

24.2 cm (9.5 in)—not terminated.

TIMING CHARACTERISTICS

| To TMS9900 from Interface Assembly | Emulation Typical | Interface Delays* Maximum (in ns) |
|------------------------------------|-------------------|-----------------------------------|
| Ø1 | 41 | 59 |
| Ø2 | 41 | 59 |
| Ø3 | 41 | 59 |
| Ø4 | 41 | 59 |
| CRUIN | 12 | 23 |
| INTREQ | 12 | 18 |
| 1C0 | 12 | 23 |
| IC1 | 12 | 23 |
| IC2 | 12 | 23 |
| IC3 | 12 | 23 |
| HOLD | 12 | 18 |
| READY | 12 | 18 |
| LOAD | 12 | 18 |
| RESET | 68 | 98 |
| DATA | 14 | 21 |

| From TMS9900 to Interface Assembly | Typical | Maximum (in ns) |
|------------------------------------|---------|-----------------|
| DBIN | 24 | 41 |
| MEMEN | 12 | 18 |
| WE | 12 | 18 |
| CRUCK | 12 | 23 |
| CRUOUT | 12 | 23 |
| HOLDA | 12 | 23 |
| WAIT | 12 | 23 |
| IAQ | 12 | 23 |
| ADDRESS | 14 | 21 |
| DATA | 14 | 21 |

*Assumes 1.5 ft of cable at 1.5 ns/ft.

Note: All inputs and outputs of the 64 pin plug at the end of the prototype control probe are buffered by 74LSXXX type devices. In all cases, data and control should not change during clock Ø1.

6500/1 EMULATOR SUPPORT PACKAGE CHARACTERISTICS

6500/1 is a trademark of Rockwell International Corporation. Tektronix, Inc. does not guarantee that other vendor's versions of these microcomputers will be compatible with Tektronix Microprocessor Labs.

PHYSICAL CHARACTERISTICS

Length — 1.8 m (6 ft)—of cable from the emulator processor to the interface assembly, 45 cm (1.5 ft) of cable from the interface assembly to the 40-pin plug.

Cable Configuration — 1.8 m (6 ft)—two 40 conductor ribbon cables with alternating ground and signal paths.

45 cm (1.5 ft)—two laminated 40 conductor cables made up of signal-ground pairs.

| | | Output Driving | Input Receiving |
|---------------------------|--------------|------------------|-----------------|
| PA0-PA7 | RISING EDGE | 1 CLK CYCLE +300 | 100 |
| | FALLING EDGE | 1 CLK CYCLE +300 | 100 |
| PB0-PB7, PC0-PC7, PD0-PD7 | RISING EDGE | 300 | * |
| | FALLING EDGE | 30 | * |
| CNTR | RISING EDGE | 100 | 100 |
| | FALLING EDGE | 20 | 20 |

*Gated in only during a read instruction from 81, 82, 83.

F8, 3870, 3872 EMULATOR SUPPORT PACKAGE CHARACTERISTICS

F8 refers to microprocessors manufactured by Fairchild's Corporation; the 3870 and 3872 refer to microcomputers manufactured by Mostek Corporation. Tektronix, Inc. does not guarantee that other vendor's versions of the F8, 3870, or 3872 will be compatible with the Tektronix Microprocessor Labs.

PHYSICAL CHARACTERISTICS

Length — 6 ft (1.8 m)—of cable from emulator processor to the interface assembly.

1 ft (30 cm)—of cable from the interface to 40 pin plug.

Cable Configuration — 6 ft (1.8 m)—two 40-conductor ribbon cables with chassis ground plane and signal paths.

1 ft (30 cm)—two 40-conductor twisted pair cables.

Termination — 6 ft (1.8 m)—interface assembly contains receivers for data, address, and control from the F8/3870/3872 Emulator Processor module.

1 ft (30 cm)—not terminated.

TIMING CHARACTERISTICS

3870/3872 — The 3870/3872 Prototype Control Probe was designed to meet all the ac characteristics of the 3870 and 3872 Microcomputers.

F8 (3850) — The F8 Prototype Control Probe meets all of the F8 ac characteristics with the following exceptions: (1) the worst-case delay from the falling edges of WRITE to the ROMC lines being valid is 650 ns (compared to 550 ns for the F8 CPU); (2) the worst-case skew between an external clock input is 0 to 90 ns longer than that specified for the F8.

1802 EMULATOR SUPPORT PACKAGE CHARACTERISTICS

PHYSICAL CHARACTERISTICS

Length — 6 ft (1.8 m) of cable from the emulator processor to the interface assembly, 1.5 ft (45 cm) of cable from the interface assembly to the 40-pin plug.

Cable Configuration — 6 ft (1.8 m)—two 40-conductor ribbon cables with alternating ground and signal paths.

1.5 ft (45 cm)—two laminated 40-conductor cables made up of signal-ground pairs.

TIMING CHARACTERISTICS

The 1802 Prototype Control Probe is designed to meet all the ac characteristics of the 1802 Microprocessor— $V_{cc} \geq 4.0$ V.

AC CHARACTERISTICS

| Emulation Clock Mode 1 or Mode 2 (user clock) with 1802 Prototype Control Probe. | 5.0 MHz max at 10 V _{cc} , 25°C, this can be crystal, or external input to clock (pin 1). |
|---|--|
| Tracking power supply to monitor user voltage (V _{cc}) and run the probe at the same voltage (4 V to 12 V). | 2.5 MHz |

INPUT/OUTPUT CHARACTERISTICS

Variable Threshold

| | |
|--------------------|--|
| Range | > +10 V dc to < -10 V dc |
| Preset TTL Voltage | +1.4 V dc \pm 200 mV |
| Event Trigger Out | High level voltage out (when V _{cc} =Min, V _i =0.5, R _o =50 Ω to GND) is > 2 V dc. |

Adjustments — Variable Threshold may be adjusted from > +10 V dc to < -10 V dc with a screwdriver adjustment accessible at the rear panel of the Microcomputer Lab. This voltage must be monitored with a voltmeter having an input impedance of at least 10 M Ω .

Jumpers — With the internal jumper in position "0-3" the clock threshold is designated to be the same as channels 0-3. In position "4-7" the jumper designates the clock threshold to be the same as channels 4-7.

Cable Length — 50 cm (19.5 in).

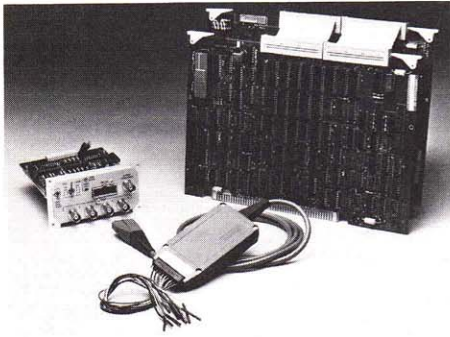

TRIGGER TRACE ANALYZER

The TEKTRONIX Trigger Trace Analyzer is designed specifically for use with either the TEKTRONIX 8550 Microcomputer Development Lab or the 8540 Integration Unit. As such, it is totally compatible with 8-bit and 16-bit support offered for either of these 8500 Series systems.

The primary function of the Trigger Trace Analyzer is to capture the real-time execution of code on the bus of the prototype system under design. This capture includes all address and data flow control information specific to the processor to be used for the prototype. In addition, an external acquisition probe allows up to eight channels of prototype hardware logic to be captured and displayed along with the bus information.

To capture specific bus transactions and hardware events, the Trigger Trace Analyzer has four trigger channels that simultaneously monitor prototype software execution and other logic transactions. These channels can be used independently or interactively to initiate a trigger upon detection of pertinent data generated from interaction of the emulator processor and prototype. For user convenience when programming the Trigger Trace Analyzer, address information can be represented by a series of symbolic labels and expressions determined by the user. Also, information acquired from the prototype address and control buses is displayed in disassembled mnemonics native to the processor in use.

62 Channels of real-time data acquisition

The Trigger Trace Analyzer (TTA) is a modular option used to monitor and store real-time execution of code on the prototype bus as generated by the emulator processor. This processor may be any one of the 16-bit or 8-bit processors supported by the TEKTRONIX 8500 Series systems. On each cycle the TTA can acquire up to 16-bits of data bus information, up to 24-bits of address information and up to 11 control bits. The particular nature of the control bits is dependent on the specific emulator being used. Each 8500 Series Emulator package defines and identifies the signals that are supported.

In addition to prototype bus information, the TTA can acquire up to eight channels of hardware logic through a TEKTRONIX P6451 probe with inputs that are either TTL and plus or minus 10 volt compatible or up to plus or minus 10 volt variable threshold. This probe is part of the TTA's optional acquisition interface. The Acquisition Interface includes a BNC input for an event qualifier signal that is assignable to any of the TTA's four trigger channels. Also included are BNC outputs for the TTA's four trigger signals.

Real-time data acquired from the prototype bus and/or hardware points is captured by a high-speed buffer, the acquisition trace memory. This memory is up to 62-bits wide and 255 words deep, and is able to resolve bus cycles up to 125 nanoseconds. To optimize the capability of the acquisition trace memory, the TTA also allows data storage qualification based on the event defined by trigger channel four.

Four trigger channels

Each of the TTA's four trigger channels consists of a word recognizer and 16-bit counter that may be used together or independently to produce a trigger. Each channel's word recognizer simultaneously monitors all of the emulator bus and external hardware acquisition bits plus four more bits representing feedback from each channel's counter output. On each bus cycle, the word recognizer looks for a specific value that has been programmed by the user. The data and address portions of the word recognizer will accommodate a range (e.g., 01237H to 35798H) as well as an individual value, and also a NOT range or individual value. Any of the address, data, and probe signals may also be set to a "don't care" value.

When the data present during a prototype bus cycle agrees with the preprogrammed word recognizer value, the word recognizer outputs an active EVENT signal. If the channel's counter output is also in an active state, the channel will produce a trigger signal. An active EVENT signal can also be used to increment/decrement any channel's counter.

Each channel's counter is 16-bits (64k) and will operate up to 5 megahertz. The counter can be programmed to access 17 different counting sources including five clock speeds and trigger signals from other channels. It may be programmed to count up or down to a maximum of 64k, and can be reset during operation. This counting function can be enabled immediately or disabled by an active trigger from its own channel or the previous channel; or by an active counter output from the previous channel. When the counter reaches its preset value, it can be used in conjunction with an active EVENT signal to produce a trigger; or to enable the next channel's counter.

When a given channel's preprogrammed word recognizer and counter values come true, the channel produces an active trigger output. The word recognizer and counter can both be used independently to produce a trigger by setting the value of the other to "don't care". Also the user may program the counter output to be constantly active, allowing the word recognizer to independently produce a trigger.

Any channel's active trigger output can cause a program execution breakpoint and halt data acquisition by the TTA's acquisition trace memory. Once the breakpoint has occurred, prototype code execution may either be stopped or allowed to continue through TTA breakpoint commands. Multiple breakpoints are possible by programming different triggers on different channels and setting each to cause a breakpoint.

Up to four prototype events occurring on consecutive bus cycles can be linked to form a single trigger. Each event is assigned to a different channel's word recognizer and then linked through a CONS command, that also specifies the type of bus cycle. When the prototype events occur in the order specified, the last event causes a trigger.

Besides triggering capabilities, two other items extend control over data acquisition. One is data qualification, which uses the event programmed into channel four as a determinant for data storage in the acquisition trace memory. When the acquired prototype information agrees with event four programming, it is committed to memory. Another command allows pre-, center- or post-trigger triggering, which determines the position of the trigger event in relation to the acquired data. In this manner the user can acquire events leading up to the trigger, following the trigger, or evenly distributed on either side of the trigger.

The TTA package includes a powerful command set similar to UNIX and a display capability to enhance the user's speed and efficiency. The TS command (trigger status display) gives a full display of the current programming content for each trigger channel. It provides a full breakdown of all values associated with both the word recognizers and counters, and also shows each channel's breakpoint programming. In addition, this command shows whether or not the trace acquisition memory is being qualified by the channel four event.

Acquired data including bus status information is displayed on a cycle-by-cycle basis in the disassembled mnemonics of the emulator processor in use. The breakpoint display identifies which trigger channel caused the break to occur and shows the status of all key registers within the processor at the breakpoint. Symbolic representation of prototype address simplifies the implementation of TTA commands.

**MODULAR DEVELOPMENT LANGUAGE
MDL/μ**

MDL/μ is a high level language designed specifically for use in microprocessor-based design. Its parent language is ANSI Minimal BASIC, a widely used and well understood programming format. MDL/μ offers an extensive number of enhancements from BASIC that make this new language an extremely effective design tool while retaining the advantages of simplicity and easy learning found in BASIC.

One essential advantage of MDL/μ is that it uses a compiler instead of an interpreter. Each program statement is translated to machine code only once, instead of every time the statement is executed. The result is faster, and often more compact code for final program execution.

MDL/μ allows a module-oriented approach to software development. Two statements, USES and PROVIDES, allow variables, functions and procedures to be shared by programmers working on different modules of an overall program. The USES statement also allows direct access to absolute memory locations, I/O ports and interrupts—all essential for proper control of hardware/software integration.

Variable names and strings have been considerably expanded with MDL/μ. Variable names can contain up to six characters, the first alphabetic and the others alphanumeric, for easy identification during program development. Strings can vary in length from 1 to 255 characters instead of the unalterable 18 used in minimal BASIC. Substring replacement is also enhanced to assist in character manipulation.

I/O features include access to ports and absolute addressing of memory, which allows variables to be assigned a specific address. Both ASCII and general purpose binary file manipulations are possible through a series of I/O statements including OPEN, CLOSE, RESTORE, READ, WRITE, PRINT and INPUT.

Among many other MDL/μ enhancements to BASIC are logical operators (AND, OR, XOR, NOT) plus shift and rotate operations for bit manipulation, DISABLE and ENABLE to turn the interrupt off and on and a built-in code optimization.

The conversion of MDL/μ source code to actual machine code is a three-step process. The first step converts MDL/μ source code into assembly language source code which is stored on a file or device. The assembly source code contains the original MDL/μ statements as comments preceding each block of assembly source code. At this stage, the assembly language can be further optimized by using the 8550's powerful editor. In the second step the assembler converts the assembly language source into object code. The third step is to link the object code with the run time support library and any other assembled object code modules.

PASCAL: HIGH-LEVEL PROGRAMMING LANGUAGE

Pascal, a high-level programming language, is receiving much attention in the electronics industry. Features such as program structure, strong data typing, and readability greatly enhance programmer efficiency, and thereby reduce software development and maintenance costs. The TEKTRONIX Pascal 8080/8085 Compiler is designed specifically for those who are writing programs for the 8080 or 8085 microprocessors. The TEKTRONIX Pascal 8080/8085 Compiler is a super-set of the ISO draft standard Pascal. A true compiler rather than a P-code interpreter, the Pascal 8080/8085 Compiler generates object code directly. Each program statement is translated to machine code only once instead of every time the statement is executed, resulting in faster and often more compact code.

Standard Pascal Features

Pascal is a block-structured language that allows the program to be divided into sub-programs called procedures and functions. This block structure encourages programmers to logically plan and construct programs, so debugging time is greatly reduced. The block structure also requires that all variable declarations occur prior to executable code.

Pascal's six control structures correspond closely with flowchart elements and make algorithm coding very natural. All control structures have a single entrance and exit unless GOTO's are used, so program modifications are unlikely to introduce errors into the program.

Pascal allows programmers to use many flexible forms of data representations and to define data types that accurately express their particular problems. Pascal also has strong data typing, which means that each variable must be defined as a single data type prior to its use and used consistently with its definitions.

Pascal programs are easy to read, and thus to maintain. Pascal differs from most line-oriented languages by allowing extra spaces, tabs, and carriage returns almost anywhere. Variable, procedure, and function names can be meaningful and easily understood because they are not restricted in length. However, identifiers used by DOS/50 must be unique in the first eight characters, other identifiers, in the first 19.

TEKTRONIX Pascal 8080/8085 Compiler Major Extensions**Separate Compilations**

Separate compilations are supported by the Pascal 8080/8085 Compiler. The main program module's first word is the keyword "PROGRAM." Submodules to be separately compiled begin with the keyword "MODULE". Global variables, procedures, and functions can be referenced between separately compiled modules and the main program via PUBLIC and EXTERN attributes. The PUBLIC and EXTERN attributes are associated with variables, procedures, and functions and cause the compiler to generate the appropriate linker text.

Linkage to Assembly Routines

Speed-critical or timing-critical applications are likely to require some program segments to be written in assembly language. Because the code generated by the Pascal 8080/8085 Compiler is compatible with the 8550 linker, assembly code can be linked to Pascal code.

Interrupt Handling

The Pascal 8080/8085 Compiler supports full use of the 8080's and 8085's interrupts. The interrupts are supported by writing the interrupt service routine as a separate procedure having the INTERRUPT attribute. Separate routines are required to connect a specific interrupt vector to the appropriate interrupt service routine. The interrupt service routines are included as convenience routines with the compiler. Procedures are also supplied to set (SIM) and read (RIM) the 8085's interrupt mask.

Input/Output

Included with the Pascal 8080/8085 Compiler are several predefined procedures and functions used for chip-level I/O. A procedure to send data to a specified port and function to read data from a specified port are included. These procedures and functions are analogous to the standard Pascal WRITE, WRITELN, READ, READLN procedures, which are available for 8550 mode 0 operation when using DOS/50 I/O. All of the 8550's I/O capability is available to a Pascal program running in emulation mode 0, so the Pascal program can access the console terminal, discs, line printer, and auxiliary I/O ports. The Pascal 8080/8085 Compiler also allows an ORIGIN attribute to be associated with variables. The ORIGIN attribute assigns variables to specific memory addresses and is very useful for memory mapped I/O.

Non-decimal Integers

In many microcomputers applications, programmers want to use non-decimal integers. The Pascal 8080/8085 Compiler supports binary, octal, and hexadecimal integers for input and output.

ROM/RAM Applications

ROM/RAM applications are facilitated by control-section typing. Control-section typing means that the compiler gives the user the information he needs to allocate program variables into a linker section separate from literals, constants, and instructions, which are put into a second linker section.

Structured Constants

Standard Pascal allows only constants of type, integer, real, boolean, and text char. The Pascal 8080/8085 Compiler also provides constants which are arrays, and records. The most common application of structured constants is to initialize structured variables (arrays and records) that must reside in potentially volatile RAM.

Metacommands

Metacommands are compiler directives that cause the compiler to do such things as format the listings or generate run-time debugging code.

Tektronix offers maintenance training classes on Microprocessor Development Labs and a variety of user workshops featuring microprocessor hardware and software design concepts. For further training information, contact your local Sales Office or request a copy of the Tektronix Customer Training Catalog on the return card.



NEW 4643 LINE PRINTER

The 4643 Line Printer is an optional system peripheral for use with the 8550, 8540, or 8560 Microcomputer Labs.

The 4643 Line Printer is RS-232C compatible and supports baud rates of 110 to 9600. Printing is bi-directional at 350 character per second. With a full 132 character line, speeds of 125 lines per minute are nominal the 7 by 7 format print font permits easy reading of both upper and lower case, and the operator can specify condensed, expanded, or standard characters. In the condensed format, the 4643 prints out a 132-character line on an 8 1/2 by 11 inch sheet.

4643 Printer (2400 Baud Standard) ... \$4200



CT8500 CRT TERMINAL

The CT8500 CRT Terminal is an optional peripheral recommended for use with the 8550, 8540 or 8560 Microcomputer Labs.

The CT8500 is serially interfaced through an EIA standard RS-232C port. The 30 cm (12 in) diagonal CRT displays up to 25 lines at 80 characters per line, and the keyboard contains a full ASCII set of characters in upper and lower case. Other key features include eight programmable function keys, split screen capability, multimode editing, scrolling, paging, and visual display attributes.

Order CT8500 CRT Terminal \$2700

MDL WORKSHOPS

Tektronix offers Microcomputer Development Lab Workshops in a number of locations throughout the year. The courses are intensive, hands-on workshops designed to help the attendee meet the demanding challenges of the growing microcomputer development market.

8550 MDL OPERATIONS WORKSHOP

The 8550 MDL Operations Workshop covers all functions of the 8550 Microprocessor Development lab, a design tool used for both software development and hardware/software integration. The 8550's features are explored in-depth and applied to a typical microcomputer design cycle. Throughout the course, the attendee gets intensive, hands-on experience for an in-depth understanding of all 8550 operations.

The course introduces the design process, flow charting a simple system and writing assembler source code for the Z80 microprocessor. Then with this background, the attendee learns to use the text editor, macro assembler, linker, I/O simulation with service calls, communication to remote computers, and the real-time software/hardware debugging tools. The 8550 MDL Operations workshop is a five-day course.

**EVALUATION AND SELECTION
OF 16-BIT
MICROPROCESSORS WORKSHOP**

The Evaluation and Selection of 16-Bit Microprocessors Workshop provides an in-depth examination of three major 16-Bit Microprocessors currently available for design implementation, the Intel 8086, Zilog Z8000 and the Motorola 68000. Each is considered in terms of hardware and software characteristics.

To provide a thorough orientation, lab sessions require the participant to write a program for each processor that solves a given application problem. Program development is accomplished using the TEKTRONIX 8550 Microprocessor Development System. Questions on processor selection, software development, prototyping, program size and through-put considerations will also be discussed.

The evaluation and selection of 16-bit Microprocessors workshop is a three-day course.

**INTRODUCTION TO
MICROPROCESSOR SOFTWARE
DESIGN WORKSHOP**

The Introduction to Microprocessor Software Design Workshop is a comprehensive look at microcomputer software development, from flowcharting through hardware/software integration. It includes hands-on experience with the 8550 Microcomputer Development Lab, a self-contained microcomputer design tool. The introduction to Microprocessor Software Design Workshop is a Five-day course.

**MICROPROCESSOR HARDWARE/
SOFTWARE INTEGRATION TECHNIQUES**

The Microprocessor Hardware/Software Integration Techniques Workshop examines various aspects of the microcomputer design cycle and the role of each in the overall development scheme. Throughout the course, the participant will work with a number of design tools commonly used in developing microprocessor-based systems. Included are the 8550 MDL, logic analyzers, oscilloscopes and data communications testers. Extensive hands-on experience is provided for each tool. The Microprocessor Hardware/ Software Integration Techniques Workshop is a Five-day course.

**MICROPROCESSOR SOFTWARE
DEVELOPMENT WITH PASCAL WORKSHOP**

The Microprocessor Software Development with Pascal Workshop is an intensive examination of Pascal and its relationship to microcomputer software development. It emphasizes how to "think" in Pascal program structure and looks at the philosophy behind the language. In addition to defining the language in terms of the ISO Pascal standard, the course introduces Tektronix's special extensions aimed specifically at developing code at the microprocessor level. Also considered are tradeoffs between using assembly or high level language for micro software development, and the process of linking Pascal modules with assembly-written modules to form a complete program. The Microprocessor Software Development with Pascal Workshop is a Five-day course.

For detail information on Tektronix Microcomputer Development Workshops and Workshop schedules, contact your local Tektronix Sales Engineer.

8540 Integration Unit

\$10,900

| Field Number | Emulators: | Factory Configuration Number | Price |
|--|--|------------------------------|---------------------|
| 8300E04 Opt 01 | Z-80A Emulator and ROM | Option 2C | \$2950 |
| 8300E06 Opt 01 | 8085 Emulator and ROM | Option 2E | \$2950 |
| 8300E20 | Z8001/Z8002 Emulator | Option 2M | \$4050 |
| 8300E28 | 68XX Emulator | Option 2Q | \$3450 |
| Probes: | | | |
| 8300P04 | Z-80A Prototype Control Probe | Option 3D | \$1050 |
| 8300P06 | 8085A Prototype Control Probe | Option 3F | \$1050 |
| 8300P20 Opt 01 | Z8001 Prototype Control Probe and ROM | Option 3Q | \$2250 |
| 8300P22 Opt 01 | Z8002 Prototype Control Probe and ROM | Option 3S | \$2250 |
| 8300P28 Opt 01 | 6809 Prototype Control Probe and ROM | Option 3V | \$1750 |
| System Options: | | | |
| 8540F01 | Comm Interface Package | Option 01 | \$400 |
| 8540F03 | Trigger Trace Analyzer and ROM | Option 03 | \$4550 |
| — | 64k Program Memory (Factory Installed) | Option 04 | \$3450 ¹ |
| 8550F04 | 64k Program Memory (Field Installed) | — | \$6550 |
| — | 128k Program Memory (Factory Installed) | Option 05 | \$6350 ¹ |
| 8550F05 | 128k Program Memory (Field Installed) | — | \$9450 |
| 8550F06 | Memory Controller | Option 06 | \$2500 |
| 8550F30 Opt 01 | PROM Controller | Option 30 | \$1650 |
| 8550F31 | 2716/32 PROM Module | Option 31 | \$650 |
| 8550F32 | 8748/41A55 PROM Module | Option 32 | \$650 |
| 040-1020-00 | Rackmount Version | Option 47 | \$250 |
| — | Universal Euro 220 V | Option A1 | NC |
| — | U.K. 240 V | Option A2 | NC |
| — | Australia 240 V | Option A3 | NC |
| — | North American 240 V | Option A4 | NC |
| ¹ This price includes credit for 32k byte standard memory module. | | | |
| Accessories: | | | |
| — | Interface Cables 8540 to 8560 | | |
| — | HSI Cable, 2.44 m (8 ft) | 012-1009-00 | \$55 |
| — | HSI Cable, 6.1 m (20 ft) | 012-1008-00 | \$90 |
| — | HSI Cable, 15.24 m (50 ft) | 012-1007-00 | \$125 |
| — | HSI Cable, 76.2 m (250 ft) | 012-1010-00 | \$395 |
| — | Interface Cables 8540 to Dataset | | |
| — | RS-232C Interface Cable 6.1 m (20 ft) blank line | 012-0757-00 | \$140 |

8560 Multi-User Software Development Unit

\$27,500

| Assemblers: | | | |
|----------------------------|------------------------------|-----------|--------|
| 8560B01 | 8080A/8085A Assembler | Option 1A | \$1500 |
| 8560B02 | 6800/6801/6802 Assembler | Option 1B | \$1500 |
| 8560B04 | Z-80A Assembler | Option 1C | \$1500 |
| 8560B15 | 8086/8088 Assembler | Option 1J | \$1500 |
| 8560B16 | Z8001/Z8002 Assembler | Option 1K | \$1500 |
| 8560B17 | 68000 Assembler | Option 1L | \$1500 |
| 8560B18 | 6809 Assembler | Option 1M | \$1500 |
| Editor: | | | |
| 8560F21 | Advanced CRT-Oriented Editor | Option 21 | \$500 |
| Software Utilities: | | | |
| 8560U01 | Text Processing Package | Option 4A | \$950 |
| 8560U02 | Native Programming Package | Option 4B | \$950 |
| 8560U03 | Auxiliary Utilities Package | Option 4C | \$500 |
| System Options: | | | |
| 8560F01 | 64k Word System Memory | Option 01 | \$4500 |
| 8560F03 | 5-8 Port Mux/License | Option 03 | \$4500 |
| — | Universal Euro 220 V | Option A1 | NC |
| — | U.K. 240 V | Option A2 | NC |
| — | Australia 240 V | Option A3 | NC |
| — | North American 240 V | Option A4 | NC |

8550 Microcomputer Development Lab

\$15,950

| Assemblers: (Requires Software License) | | | |
|---|---|-----------|--------|
| 8300A01 | 8080A/8085A Assembler | Option 1A | \$950 |
| 8300A02 | 6800/6801/6802 Assembler | Option 1B | \$950 |
| 8300A04 | Z-80A Assembler | Option 1C | \$950 |
| 8300A05 | TMS9900 Assembler | Option 1D | \$1050 |
| 8300A07 | 3870/3872/F8 Assembler | Option 1E | \$950 |
| 8300A09 | 1802 Assembler | Option 1F | \$950 |
| 8300A10 | 8048/8021/8041A/8022 Assembler | Option 1G | \$950 |
| 8300A14 | 6500/1 Assembler | Option 1H | \$950 |
| 8300B15 | 8086/8088 Assembler | Option 1T | \$1200 |
| 8300B20 | Z8000 Assembler | Option 1U | \$1200 |
| 8300B26 | 68000 Assembler | Option 1V | \$1200 |
| 8300A28 | 6809 Assembler | Option 1M | \$950 |
| Emulators: | | | |
| 8300E01 | 8080A Emulator Processor and Emulator Control Software | Option 2A | \$2650 |
| 8300E02 | 6800/6802 Emulator Processor and Emulator Control Software | Option 2B | \$2650 |
| 8300E04 | Z-80A Emulator Processor and Emulator Control Software | Option 2C | \$2650 |
| 8300E05 | TMS9900 Emulator Processor and Emulator Control Software | Option 2D | \$3465 |
| 8300E06 | 8085A Emulator Processor and Emulator Control Software | Option 2E | \$2650 |
| 8300E07 | 3870/3872/F8 Emulator Processor and Emulator Control Software | Option 2F | \$3150 |
| 8300E09 | 1802 Emulator Processor and Emulator Control Software | Option 2G | \$3465 |
| 8300E10 | 8048/8021/8041A/8022 Emulator Processor and Emulator Control Software (requires 8300P10, 8300P12, or 8300P13) | Option 2H | \$2950 |
| 8300E14 | 6500/1 Emulator Processor, Prototype Control Probe | | \$3340 |
| 8300E20 | Z8001/Z8002 Emulator | Option 2M | \$4050 |
| 8300E28 | 68XX Emulator | Option 2Q | \$3450 |

8550 Microcomputer Development Lab (Cont.)

| Field Number | | Factory Configuration Number* | Price |
|--|---|-------------------------------|--------|
| Probes: | | | |
| 8300P01 | 8080A Prototype Control Probe | Option 3A | \$1050 |
| 8300P02 | 6800 Prototype Control Probe | Option 3B | \$1050 |
| 8300P03 | 6802 Prototype Control Probe | Option 3C | \$1050 |
| 8300P04 | Z-80A Prototype Control Probe | Option 3D | \$1050 |
| 8300P05 | TMS9900 Prototype Control Probe | Option 3E | \$1280 |
| 8300P06 | 8085A Prototype Control Probe | Option 3F | \$1050 |
| 8300P07 | 3870/3872 Prototype Control Probe | Option 3G | \$1050 |
| 8300P08 | F8 Prototype Control Probe | Option 3H | \$1050 |
| 8300P09 | 1802 Prototype Control Probe | Option 3J | \$1050 |
| 8300P10 | 8048 Prototype Control Probe | Option 3K | \$1250 |
| 8300P11 | 8021 Adapter (requires 8300P10) | Option 3L | \$375 |
| 8300P12 | 8041A Prototype Control Probe | Option 3M | \$1250 |
| 8300P13 | 8022 Prototype Control Probe | Option 3N | \$1250 |
| 8300P20 | Z8001 Prototype Control Probe and Emulator Software | Option 3Q | \$1850 |
| 8300P22 | Z8002 Prototype Control Probe and Emulator Software | Option 3S | \$1850 |
| 8300P28 | 6809 Prototype Control Probe and Emulator Software | Option 3V | \$1450 |
| Language Products: (Requires Software License) | | | |
| 8300G01 | Pascal 8080/8085** | Option 1P | \$1950 |
| 8300H01 | Modular Development Language: 8080/8085/Z-80** | Option 1Q | \$1100 |
| 8300H02 | Modular Development Language: 6800/6802** | Option 1R | \$1100 |
| Editor (Requires Software License) | | | |
| 8300C01 | Advance CRT - Oriented Editor* | | \$500 |
| System Options: | | | |
| 8550F01 | Real Time Prototype Analyzer | Option 01 | \$2700 |
| 8550F02 | 32k Static Memory Board | Option 02 | \$3100 |
| 8550F03 | Trigger Trace Analyzer | Option 03 | \$4150 |
| 8550F04 | 64k Program Memory (Ordered with system) | | \$6550 |
| — | 64k Program Memory | Option 04 | \$3450 |
| 8550F05 | 128k Program Memory | | \$9450 |
| — | 128k Program Memory (Ordered with system) | Option 05 | \$6350 |
| 8550F06 | Memory Allocation Controller | Option 06 | \$2500 |
| 8550 | Universal Euro 220 V/16A Power | Option A1 | NC |
| 8550 | U.K. 240 V/13A Power | Option A2 | NC |
| 8550 | North American 240 V/15A Power | Option A4 | NC |
| 8550 | Switzerland 240 V/15A Power | Option A5 | NC |
| Editor (Requires Software License) | | | |
| 8550 | Advance CRT - Oriented Editor* | Option 1S | \$500 |
| System Options: | | | |
| Peripherals: | | | |
| 4643 | Line Printer | | \$4200 |
| CT8500 | CRT Terminal | | \$2700 |
| Accessories: | | | |
| RS-232 | Interconnecting cable 012-0757-00 (300 cm — 10 ft) | | \$140 |
| Null-Modem | Interconnecting cable 012-0820-00 (150 cm — 5 ft) | | \$80 |

**Order the products as 8540 or 8550 options to have the system factory configured and tested.

*Requires 64k Program memory.

ORDER MATRIX

To use the matrix below:

- Identify the mainframe (8540 or 8550).
- Select a processor (8080, 8085, Z-80, 6800, etc.).
- Select a level of support (assembler, emulator, probe, HLL, Prototype Debug).
- Order mainframe and options for deemed level of support.*

| Processor | 8540 | | | 8550 | | | 8560 |
|------------------|-----------|-----------|-----------|------------------------|------------------------|---------------|-----------|
| | Emulator | Probe | Assembler | Emulator | Probe | HLL | Assembler |
| 8080 | | | Option 1A | Option 2A | Option 3A | Option 1P, 1Q | Option 1A |
| 8085 | Option 2E | Option 3F | Option 1A | Option 2E | Option 3F | Option 1P, 1Q | Option 1A |
| Z-80 | Option 2C | Option 3D | Option 1C | Option 2C | Option 3D | Option 1Q | Option 1C |
| 6800 | | | Option 1B | Option 2B | Option 3B | Option 1R | |
| 6802/6808 | | | Option 1B | Option 2B | Option 3C | Option 1R | |
| TMS9900 | | | Option 1D | Option 2D | Option 3E | | |
| 3870/72/74/76 | | | Option 1E | Option 2F | Option 3G | | |
| F8 | | | Option 1E | Option 2F | Option 3H | | |
| 1802 | | | Option 1F | Option 2G | Option 3J | | |
| 8048/8035/8039-6 | | | Option 1G | Option 2H | Option 3K | | |
| 8021 | | | Option 1G | Option 2H | Option 3L ¹ | | |
| 8041A | | | Option 1G | Option 2H | Option 3M | | |
| 8022 | | | Option 1G | Option 2H | Option 3N | | |
| 6500/1 | | | Option 1H | Option 2J ² | | | |
| 6809 | Option 2Q | Option 3V | Option 1M | Option 2Q | Option 3V | | Option 1M |
| 8086 | Option 2K | Option 3P | Option 1T | | | | Option 1J |
| 8088 | Option 2K | Option 3X | Option 1T | Option 2K | Option 3X | | |
| Z8001 | Option 2M | Option 3Q | Option 1U | Option 2M | Option 3Q | | Option 1J |
| Z8002 | Option 2M | Option 3S | Option 1U | Option 2M | Option 3S | | Option 1K |
| 68000 | Option 2P | Option 3U | Option 1V | Option 3P | Option 3V | | Option 1K |

¹Requires Option 3K

²Includes Probe

*NOTE: If this support is to be added to a previously purchased mainframe, use the equivalent product nomenclature, i.e., FIELD NUMBER (NOT the factory configuration option number) when placing your order.

DATA COMMUNICATION ANALYZERS

CONTENTS

| | |
|--|----|
| 834 Programmable Data Communication Tester | 27 |
| 834RDA ROM Development Aid | 29 |
| ROM Packs | 30 |
| 833/832 Data Communication Tester | 32 |
| 830 Series Line Comparison | 34 |
| 851 Digital Tester | 35 |



Bisynchronous System Exercising

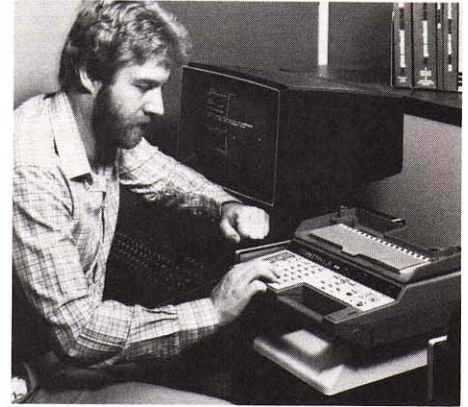

Communications System Monitoring



Communications Equipment Check-out

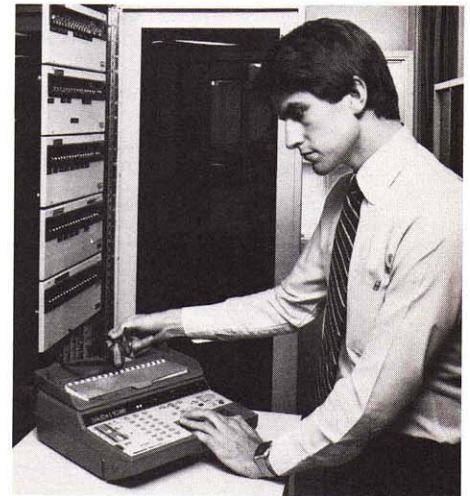

Data Link Testing



834

Programmable

Allows Automation of Tests

Easy to Operate

19.2 k Baud Data Transfer

Handles ASYNC/BISYNC/HDLC

2699 Character Buffer

16 Character Display

Bit Error Rate Testing

Portable and Lightweight

The TEKTRONIX 834 Programmable Data Communications Tester is a powerful network troubleshooter designed to meet the demand for cost and time-effective first-line field service. The 834's portability (5.5 kg, 12 lb), ruggedness, and ease of use gives you a welcome independence from bulky, expensive equipment.

The 834, like our 833, monitors and is compatible with EIA RS-232, and CCITT V.24 interfaces (optional interfaces also available); provides DTE and DCE simulation to evaluate the entire network; Bit Error Rate Testing for analyzing phone lines and modems; the ability to calculate and confirm block check characters; and internal self-diagnostics.

The fast 19.2 kilobaud rate lets you test the most modern networks. The bright 16 character front panel display is fully decoded in ASCII, EBCDIC, HEX, or your own character set.

We've programmed common test messages and setups into a series of optional User ROM Packs that field personnel easily slip into the 834 to quickly isolate faults. The Packs can set up the front panel controls automatically, or allow the user to execute specific test programs for special on-site applications.

MODES OF OPERATION

Monitor

The 834 monitors and records activity occurring on the RS-232 interface without interfering with data transmission. Trigger capability allows selective capture of data (refer to Triggering).

Modem (DCE) Simulation

In this mode, the 834 functions as Data Communications Equipment (DCE) or modem simulator for testing the Data Terminal Equipment (DTE). Messages can be sent to the unit under test (UUT), and messages received from the UUT can be examined for trigger events which can cause further action by the 834. The sequence of events is controlled by a stored program (in the 834) which can be manually entered or stored in a user defined ROM (refer to Programmability).

Terminal (DTE) Simulation

In this mode, the 834 performs as Data Terminal Equipment (DTE) or terminal simulator for testing the Data Communications Equipment (DCE) side of the interface. Otherwise, operation is similar to the modem (DCE) simulator mode described above.

Bert Mode

In this mode the 834 performs bit and block error rate testing using the 511 bit CCITT standard pseudo-random pattern.

Self Test Mode

In this mode, internal diagnostics and exercising routines can be called up by the operator to verify that the instrument is functioning properly.

INTERFACE COMPATIBILITY

The 834 is compatible with EIA RS-232 and CCITT V.24 interfaces (optional interfaces also available).

ELECTRICAL

Data Transmission Timing — Synchronous and Asynchronous.

Communications Mode — Half or full-duplex.

Bits Per Character — 5, 6, 7, 8, 9, 5 bit/character cannot be selected with parity; 9 bit/character cannot be selected without parity and in the asynchronous mode only.

Codes — ASCII, EBCDIC, HEX standard. Space available for user defined codes in an optional USER ROM.

DATA TRANSFER RATES

Internal (crystal controlled) — 50, 75, 110, 134.5, 150, 200, 300, 600, 1200, 1800, 2400, 4800, 7200, 9600, and 19,200 bits per second. (Synchronous full-duplex restricted to ≤ 9600 bits per second.)

External — Limited to maximum of 19,200 bits per second. Synchronous full-duplex restricted to ≤ 9600 bits per second.

Parity — None, Odd, Even, all Mark, all Space.

RTS/CTS Delay (Half-Duplex Mode Only) — Programmable from 0 to 9999 ms. If not programmed, defaults to 200 ms.

Accuracy — +5, -15 ms.

Block Check Characters — CRC-16, CRC-CCITT, LRC.

Bit Error Rate/Block Error Rate Tests — Utilizes the 511-bit CCITT standard pseudo-random pattern sent in blocks of 1000 bits; errors are counted continuously or over a total test length of 10^5 or 10^6 bits; stores bits in error, blocks sent, blocks in error and sync faults. (See 834R03 link test ROM pack for additional capabilities).

SET-UPS

ASYNCHRONOUS OPERATION

Stop Bits — Transmits 1, 1.5 or 2. Responds to 1.

End of Frame — One programmable character (any bit combination). Defaults to OA. (ASCII New line).

Timing — Normal or Isochronous.

SYNCHRONOUS OPERATION

Synchronizing Character — Programmable to require any 1 or 2 characters (if 2, they may be different). Defaults to 32 32.

End of Frame — Programmable to recognize any of a number of idle conditions (Mark, Space, Syn) and/or a single character (defaults to 37, EBCDIC EOT).

Clock — Normal, Derived, DTE.

HDLC OPERATION

NRZI — On or Off.

Clock — Normal, Derived, DTE.

TRIGGERING

Trigger Location in Buffer — Start, Center, End.

Match — Source of data being searched for trigger events: (NONE, DTE, DCE).

Trigger Sequence — Programmable to require a sequence of 0-25 characters (0-5 if no mask programmed).

Mask Sequence — Programmable to mask a 0-25 character trigger sequence.

Error Conditions — In Async: A parity or frame error. In Sync: A parity error. In HDLC: A CRC error, an abort sequence, or a short frame (<32 bits).

Marker — Low-to-high or high-to-low transition of marker input can be selected.

Buffer Capacity — 2699 characters.

PROGRAMMABILITY

Program Steps — 99 steps available.

Message Lengths — 50 messages totaling 3000 bytes.

Data Captured — Always the last 2699 characters received before the program stops or before STOP is pressed.

Instruction Set —

HALT: mm

Stop and display message MM.

SEND: mm

Send contents of message buffer MM as a frame.

RECEIVE

Obtain next complete data frame for processing.

COMPARE: mm

Search frame for a match with message buffer MM.

JUMP EQ: ss

Jump to step SS if a match is found.

JUMP NE: ss

Jump to step SS if a match is not found.

JUMP: ss

Jump to step SS.

IF TIME: ss

Jump to step SS if the timer expires.

TIME OUT # pp

Start timer with value parameter PP.

MASK: mm

Use message MM for mask during COMPARE operation.

WAIT #pp

Start time with value in parameter PP and do not proceed to following step until timer expires (10 to 9999 ms). (additional instructions available in ROM packs).

BREAKOUT PANEL

Probe —

Space: $+3\text{ V} \leq V_{in} \leq +25\text{ V}$.

Mark: $-25\text{ V} \leq V_{in} \leq -3\text{ V}$.

Input Impedance: $\geq 50\text{ k}\Omega$.

Marker —

Mark or Off: $-25\text{ V} \leq V_{in} \leq +0.8\text{ V}$.

Space or On: $+2\text{ V} \leq V_{in} \leq +25\text{ V}$ (Schmitt Input).

+12 Volt Source — $+12\text{ V} \pm 1\text{ V}$ (no load). Output impedance $\approx 3\text{ k}\Omega$ (each pin).

-12 Volt Source — $-12\text{ V} \pm 1\text{ V}$ (no load). Output impedance $\approx 3\text{ k}\Omega$ (each pin).

DISPLAY

Alphanumeric Display — 16-digit fluorescent display. Each digit is a 5 x 7 dot matrix 9 mm (0.35 in) high. LED status indicators for control lines.

PHYSICAL CHARACTERISTICS

Dimensions and weights (approx.)

| Dimensions | mm | in |
|------------|-----|------|
| Height | 102 | 4.0 |
| Width | 305 | 12.1 |
| Length | 306 | 12.4 |
| Weight | kg | lb |
| Net | 5.5 | 12 |

POWER REQUIREMENTS

Line Voltage Ranges — 115 V — 90 to 132 V. 230 V — 180 to 250 V.

Line Frequency Range — 48 to 440 Hz.

ENVIRONMENTAL

Temperature — Operating: 0° to $+50^\circ\text{C}$ ($+32^\circ$ to $+122^\circ\text{F}$). Nonoperating: -40° to $+75^\circ\text{C}$ (-40° to $+167^\circ\text{F}$).

Humidity — 30° to 60°C , 95% relative humidity.

Altitude — Operating: to 4500 m (15,000 ft). Nonoperating: to 15,000 m (50,000 ft).

Shock — 50 gs, 1/2 sine. 11 ms duration, in each major axis.

INCLUDED ACCESSORIES

RS-232 cable assembly, jumper set (198-4006-00), power cord —US, 115 V (other optional) (161-0066-00).

ORDERING INFORMATION

834 Programmable Data

Communications Tester \$3990

Option 02 Current Loop Interface Add \$300

Option 03 RS449 (RS422/RS423) Interface Add \$750

Option 04 MIL. STD. 188C Add \$350

INTERNATIONAL POWER CORD AND PLUG OPTIONS

Option A1 Universal Euro 220 V/16 A No Charge

Option A2 UK 240 V/13 A No Charge

Option A3 Australian 240 V/10 A No Charge

Option A4 North American 240 V/15 A No Charge

ROM PACKS

834R01 General Purpose ROM Pack \$280

834R02 Bisynchronous ROM Pack \$320

834R03 Link Test ROM Pack \$370

834R04 HDLC/X25 ROM Pack \$450

834R05 Extended Instruction Set ROM Pack \$240

834R07 PARS/IPARS ROM Pack \$375

834RDA ROM Development Aid ROM Pack \$1200

OPTIONAL ACCESSORIES

Current Loop Pod Accessory 015-0361-00 \$325

RS449 Interface A6741 \$750

User ROM Pack (empty) 020-0607-00 \$80

Diagnostic ROM Pack 067-0986-00 \$480

Carrying Case 016-0672-00 \$70





834RDA

The System For Developing Customer User ROMs For 834 ROM Packs

The 834RDA ROM Development Aid, when used in conjunction with an 834 Programmable Data Communications Tester, enables the development of new, custom EPROMs for automating or preprogramming unique customer applications in 834 ROM Packs.

The 834RDA supports the generation and editing of user-defined programs, setups and messages. The 834RDA also aids the user in extending the BAUD, CODE, IDLE and transfer function DIRECTORY menus by adding new menu entries.

PROM's are developed by building a ROM image in the 834 system. The 834RDA uses the RS-232 port for external communications. This communication port can be interfaced to any one of the following devices: (1) An external PROM Programmer; (2) A Printer or Terminal; (3) A unit under test. The 834RDA and 834 are used with an external PROM programmer to write and read PROMs. A terminal or printer may also be used with the system to produce formatted listings of the ROM image contents. With the 834RDA system connected to the unit under test, the ROM image can be executed to verify operation and correctness.

A ROM header name is generated from the user's input. All other header and trailer information are automatically supplied for individual entries and for the entire ROM image.

The 834RDA includes two additional CODE menu items. The KEYS translation code produces a one-character representation of each key, and is used when editing key sequences. The DISPLAY translation code makes all display characters of the 834 available to the user for building new code translation tables.

Extended instructions that are included in most other 834RXX ROM Packs are available to the user in the 834RDA (see page 30).

FUNCTIONS OF THE ROM DEVELOPMENT AID

Record Mode — The Record Mode of the 834RDA enables the user to record keystrokes. In this mode, all keystrokes are recorded in the order in which they are entered until the exit command is executed. Afterwards, the keystroke sequences may be edited and non-key functions (such as mode changes) added. Record mode is

a simple method of capturing user setups, programs and message strings, particularly those which involve more than one simple setup or program entry. This method of development also enables the user to optimize memory utilization in the ROM image.

Save-Setup Function — The Save-Setup Function generates a sequence of keystrokes which will recreate any of the 834 menu listings: Setup menus, Simulation Programs (including message strings and parameters), Trigger Strings, Monitor Programs, Bit Error Rate Test setups and message strings. The Save-Setup function is the easiest and most precise method of creating and storing key sequences which contain only a single menu list.

FORM Entry Functions — New entries may be added to the ROM image using the form Entry Functions. The types of entries which can be added are:

- Keystroke Sequences
- Character Strings (messages)
- Directory Entries
- Baud Rates
- Sync Idle Characters
- Translation Code Tables
- Power-Up Key Sequences

Input-Output Functions — The 834RDA system can accept input from any PROM burner that supports the TEKHEX format. Error detection checks are made to assure correct image transfer from the burner to the 834. The ROM image contains all of the completed entries plus the appropriate "overhead" data such as header, trailer, byte counts and checksum information. Upon completion of new entries or changes to the ROM image contents, the 834RDA system can send the completed ROM image back to a PROM burner.

A listing of the entire ROM image or of individual entries can be sent to a printer or terminal for documenting purposes. The printout contains key sequences (e.g., designation of keys), or function definitions (e.g., new baud rate) and other appropriate information as required.

The 834 must be in DTE SIM or DCE SIM mode when using external equipment. The mode setting should be compatible with the equipment being used, i.e., DCE SIM when interfacing a printer, PROM burner or DTE under test; DTE SIM when interfacing modems or other DCE.

Program Debug Functions — The Program Debug Functions contained in the 834RDA enable the user to: Interrupt an executing 834 program; Display program steps, parameters, and messages; Cause single step program execution; Set a breakpoint; Change program steps, parameters, and messages.

Program Enhancement Capability — Two new functions are available for assistance when creating simulation programs with the 834RDA systems. One function enables the user to insert a step in a program; the second will delete a step. In both cases, the remaining program steps will be renumbered, and all jump instructions will be adjusted accordingly.

TRANSFER FUNCTIONS AVAILABLE IN 834RDA

Insert program step at location currently shown on 834 display

Delete program step at location currently shown on 834 display

Start 834RDA Recording Mode

Stop 834RDA Recording Mode

Save program or setups

Enter RDA Mode at initial location

Setup 834 with RDA setup parameters

Setup 834 with normal 834 default setup parameters

Display RDA Directory

TRANSFER KEY — Enter RDA mode at location from which last existed. (Above list does not include functions available in 834).

ADDITIONAL INFORMATION

The 834RDA should be used with an 834 having level 04 or greater software. This can be verified by placing the 834 in self-test mode; scrolling down two levels to the LIST-DSROM display; then over one entry to LIST-CSROM; Press the start key; the display will read "CSRM:PN=0836-04: or similar. This is the part number of the ROM containing the pertinent 834 software, and the last two digits should be 04 or greater.

A level 04 or greater ROM is supplied with each RDA in case it is needed. If it is not, the ROM can be erased and used for recording your custom routines.

If additional information or updates are required, contact your local Tektronix Sales or Service Center.

The 834RDA system is compatible with several PROM burners. The PROM burners must have an RS-232 interface port, and must support Tektronix Hexadecimal (TEKHEX) transmission formatting. Some examples of 834RDA compatible PROM burners are:

- Data I/O System 19
- Data I/O System 17 (with either TEKHEX transmission formatting, or remote-control setup capability)
- PRO-LOG, M980 (requiring an RS-232 adapter)
- TEKTRONIX 8550 Microprocessor Development Lab

Order 834RDA ROM Pack Development Aid ROM Pack \$1200

834 ROM Packs

These products are firmware extensions of the 834 Programmable Data Communications Tester. These ROM Packs (834R01, 2, 3, 4, 5, 7) all contain the extended instruction set listed at the right side of this page. They also include program debug and edit functions plus the unique capabilities listed for each individual ROM Pack. (Except as noted*).

In each ROM Pack a certain number of ROM spaces are reserved for customer use. Each ROM space can accommodate a 2k or 4k ROM or EPROM. The custom ROM area of the ROM Pack can be programmed using 2716, 2732, 2516 or 2532 single power supply EPROMs or combination of the above.

As new ROM Packs have been introduced and existing ROM Packs enhanced, the firmware in the 834 has been expanded. The description for



834R01

General Purpose ROM Pack

This ROM Pack simplifies and expands operation of the 834 Data Communications Tester for use with asynchronous systems.

The capabilities programmed into the 834R01 are as follows:

Sets up conditions for asynchronous operation upon instrument power up.

The addition of correspondence and baudot character decode tables.

Additional idle menu selection.

Split baud rate capability allowing the change of either the transmit or receive baud rate.

Basic printer tasks:

Tester sends a message in lines of increasing length to a DTE to verify that characters are positioned and printed properly. Test also evaluates DTR response and X-on, X-off feature.

Repeat mode (with and without trigger).

Correspondence code set-up. (This sets the 834 to the most common asynchronous setups available).

Baudot code set-up. (This sets up the 834 for the most common Baudot code set-up.)

Block asynchronous setup. (This sets up the 834 to operate in the block-asynchronous mode.)

Graphic test patterns. This program is useful for calibrating screen attributes in TEKTRONIX 4010 Series Terminals.

Level 3 or higher 834 software required.

each ROM Pack includes the 834 firmware revision level required to make available all the capabilities of the ROM Pack. New 834's are shipped with the latest firmware and will support all the 834 ROM Packs in this catalog.

The software level of older 834s can be easily verified as follows:

Place 834 in Self-Test mode.

Scroll down two levels (press ↓ key twice) to the LIST DSROM display.

Press the ← key once to obtain the LIST CSROM display.

Press START key.

The display will read CSROM=PN=836-XX.

The last two digits indicate the software level of the 834 Data Communications Tester.

Contact your local Tektronix Sales or Service Center if additional information or updates are required.



834R02

Bisynchronous ROM Pack

This ROM Pack extends and simplifies use of the 834 in exercising components of the IBM 3270 Information Display System family and compatible terminals manufactured by other companies.

The capabilities programmed into the 834R02 are as follows:

Monitor Routines:

Trigger on NAK.

Trigger on RVI.

Attribute Exercise Pattern.

"E" Alignment Patterns.

New Line/End-of-Message Pattern.

81 Character Stairstep Pattern.

Control Key Response Test.

Calculate BCC (STX to ETX or SOH to ETX).

Terminal Startup.

Read and Display Terminal Status.

Setup for ASCII Bisync.

Setup for EBCDIC Bisync.

Load Common Protocol Messages and Parameters.

Level 3 or higher 834 software required.

EXTENDED INSTRUCTION SET

- 11 LOAD # pp**
Load register with value in parameter PP
 - 12 STORE # pp**
Store register value in parameter PP
 - 13 COMPARE # pp**
Compare register value to value in parameter PP
 - 14 INCRMNT # pp**
Increment value in parameter PP by one
 - 15 DECRMNT # pp**
Decrement value in parameter PP by one
 - 16 DISPLAY # pp**
Display value in parameter PP
 - 17 LOAD: mm**
Load register with character from message MM
 - 18 STORE: mm**
Store register value in message MM
 - 19 DISPLAY: mm**
Display message MM
 - 20 CLEAR: mm**
Clear message MM
 - 21 TRANSFR # pp**
Invoke key sequence described by value in parameter PP
 - 22 SETEIA = nn**
Set EIA RS-232 control line specified by value NN
 - 23 TESTEIA = nn**
Test EIA RS-232 control line specified by value NN
 - 24 TESTFRM = nn**
Test for type of frame indicated by value NN
 - 25 TESTKEY = nn**
Test for keyboard input indicated by value NN
 - 26 BREAK # pp**
Send BREAK for length of time specified in parameter PP
 - *27 BCC: mm**
Calculate and insert BCC for message MM
 - *28 PROTOCOL**
Enables customized BCC calculation for particular protocols and translation codes
 - *29 BLOCK: mm**
Compare frame to message buffer MM and count bit errors
 - *30 CLEAR # pp**
Set contents of parameter PP to zero
 - *31 CALL → ss**
Program execution continues at step SS after placing the number (SS+1) in the register.
 - *32 RETURN # pp**
Program execution continues at step number contained in parameter PP
 - *33 OVERLAY # pp**
Invoke transfer function xx, where xx is the contents of parameter PP
- A colon (:)** indicates that the argument to be specified is a message.
- A pound sign (#)** indicates that the argument to be specified is a parameter.
- An equal sign (=)** indicates the value to be specified is to be used in the execution of the instruction.
- An arrow (->)** indicates transfer to another program step.
- *Not in 834R01**



834R03 Link Test ROM Pack

This ROM Pack affords an extended set of transfer functions especially designed for testing Data Communication Links, and an extended variety of test patterns and lengths for Bit Error Rate testing.

834R03 additions to basic 834:

- Extra patterns 63, 2047, 1:1, 1:0, 0:1, 3:1, 1:3, 7:1, 1:7.
- Extra test lengths 10^4 , 10^7 .
- Alternate block size—511 bits (V.52).
- Alternate test-bias distortion.
- Alternate termination—minutes.
- Split baud rates.

Simulation tests

- Handshake test.
- Ping-pong test (half and full duplex).
- Half duplex BERT (V.52 compatible).

Over and Under baud rate test $\pm 1, 2.5\%$.
Block compare simulation instruction.
Level 3 or higher 834 software required.



834R04 HDLC/X.25 ROM Pack

This ROM Pack expands the operational scope of the 834 Data Communications Tester to include monitoring and simulating HDLC and X.25 packet switching networks and their components. It provides the user with frame-by-frame or packet-by-packet analysis of data exchanges and the ability to construct HDLC-formatted frames under application control.

Included in 834R04 are:

- HDLC frame analysis and mnemonic summary.
- X.25 packet analysis and mnemonic summary.
- HDLC frame assembly instruction (PACKFRM).
- Frame parameters available for program-controlled variations.

Level 5 or higher 834 software required.



834R05 Extended Instruction Set ROM Pack

This ROM Pack is for users with unique application requirements that cannot be fulfilled by the standard application programming included in other ROM Packs. The 834R05 contains the extended instruction set and program debug and edit functions. The remainder of the ROM Pack is reserved for user application ROMs.

The 834R05 reserves room for three user ROMs.
Level 4 or higher 834 software required.



834R07 PARS/IPARS ROM Pack

This ROM Pack expands the operation of the 834 Data Communications Tester for testing Programmed Airline Reservation Systems.

Included in the ROM Pack are the following:

- SABRE Translation
- Reversed Hexidecimal Translation
- Inverted Data Capabilities
- DIRECT POLL which continually sends a GO Ahead message and looks for replies after each poll
- 768 E-Pattern (64 X 12) for terminal alignment
- 960 E-Pattern (64 X 15) for terminal alignment
- 65 Character Print (64 X 12) "Stairstep" pattern
- RESET TERMINAL - Sends terminal reset command (3E HEX) to interchange unit to effect erasure of all terminal screens
- TERMINAL ECHO - Polls an interchange and when text message is received, echoes that message back to the originating terminal
- PRINTER TEST - Tests new line function

TERMINAL SIMULATION — Responds to: Direct polls; write, erase/write commands; unsolicited message commands

ASCU SET-UPS - For communicating to Agent Set Control Unit Equipment

Level 4 or higher 834 software required.

ORDERING INFORMATION

| | |
|--|-------|
| 834R01 General Purpose ROM Pack .. | \$280 |
| 834R02 Bisynchronous ROM Pack | \$320 |
| 834R03 Link Test ROM Pack | \$370 |
| 834R04 HDLC/X.25 ROM Pack | \$450 |
| 834R05 Extended Instruction Set ROM Pack | \$240 |
| 834R07 PARS/IPARS ROM Pack | \$375 |



Additional ROM Packs will become available through the year to handle a wide variety of applications.



833

256 Character Buffer

Bit Error Rate Testing

CRC Character Calculation

String Search

Easy to Operate

Portable and Lightweight

The TEKTRONIX 833 Data Communications Tester is a high-performance, first-line service tool that provides the service technician with the means to locate problems in a data communications network. The 833 is lightweight (under 5.5 kg/12 pounds), compact, and portable. Keypad entry and an easy to understand front panel simplify learning to use the 833. A string search function permits automatic examination of stored data.

833 Data Communications Tester operates on RS-232, CCITT V.24, or current loop (option) interfaces. The 833 can MONITOR the DCE and DTE in synchronous, asynchronous, and HDLC modes. HDLC data streams can be either standard or NRZI-encoded. The 833 can SIMULATE the DCE in synchronous and asynchronous modes and can also calculate and verify CRC-16, CCITT-CRC and LRC-8 block check characters.

For checking modems and phone lines, the 833 features bit error rate testing capabilities.

ECHO and REPEAT modes are also part of the 833's capabilities.

Built-in, self diagnostic routines can assure you at any time that the 833, like the 834 and 832, is operating properly.

833/832 PROM OPTIONS

The 833/832 user PROM feature gives the firstline service force a pre-programmed series of tests. This PROM is user-defined for specific applications so the 833/832 can be customized to fit particular service needs. Use this PROM to perform frequently used standard test sequences, and then, if necessary, create test sequences directly in the 833/832 to make more specific tests and further isolate faults.

Support materials (manuals, user's guides) and video tape training aids are available for all Data Communications Testers.

For more information about how Data Communications Testers can help you identify problems in data communications systems, contact your Tektronix Sales Engineer.

In the U.S., write Tektronix, Inc., U.S. Marketing, P.O. Box 1700, Beaverton, OR 97075. In Africa, Europe, Middle East write Tektronix Europe B.V. European Headquarters, Postbox 827, 1180 AV Amstelveen, The Netherlands. In Asia, Australia, Japan, Central and South America write Tektronix, Inc., Export Marketing, P.O. Box 500, Beaverton, OR 97077.

832

Low Cost

256 Character Buffer

Easy to Operate Key Pad

Portable and Lightweight

The TEKTRONIX 832 Data Comm Tester is a portable digital service instrument which can be used to direct the user to possible problems in data communications systems. It can monitor, analyze, test and trouble-shoot data communications interfaces that conform to EIA standard RS-232-C, CCITT V.24 or current loop (option). The 832 operates as a serial data transmission monitor or as a modem simulator for off-line testing of data terminal equipment (DTE).

In MONITOR mode the 832 reads and selectively records DTE data and Data Communications Equipment (DCE) data, as well as recording the status of key interface lines.

In SIMULATE mode the 832 simulates the operation of a modem. The 832 can send a message to the DTE and record its response. This data can be sent directly from the 832 or can be transmitted upon receipt of an expected trigger from the DTE.

ECHO mode is the same as SIMULATE, except the 832 sends back to the DTE (echoes) any character sent by the DTE.

In REPEAT mode the 832 can send data repeatedly to the DTE, or the 832 can be programmed to repeat the transmission only upon receipt of an expected trigger from the DTE.

In each of these modes, the 832 can operate at data rates from 50 to 9600 baud; full or half duplex; synchronously or asynchronously; with odd, even or no parity; and with characters from 5 to 8 bits long. HDLC and current loop options are available.

833/832 CHARACTERISTICS

ELECTRICAL

Data Transmission Timing — Synchronous and asynchronous.

Communications Mode — Half- or full-duplex.

Bits Per Character — 5, 6, 7, 8, 9. 5 bit/character cannot be selected with parity; 9 bit/character, cannot be selected without parity and available with 833 only.

Data Transfer Rates — Internal (crystal controlled) — 50, 75, 110, 134.5, 150, 200, 300, 600, 1200, 1800, 2400, and 4800 bits per second. 9600 bits per second at 8 bits per character, half duplex only. Accuracy — within 0.5%. External — Determined by the DCE or DTE clock.

Parity — Odd, even, or none.

RTS/CTS Delay, (half-duplex mode only) — Programmable from 0 to 255 ms. If not programmed, defaults to 200 ms. Accuracy — Within 1% ± 1 ms.

Trigger — Programmable to require a sequence of 1, 2, or 3 characters.

Trigger Position — Location of last trigger character in Receive Buffer: Post Trig, 000; Center, 127; Pre Trig, 255.

832 ONLY

Synchronizing Character (SYN), (synchronous mode only) — Programmable to require one character, or two equal characters. If not programmed, defaults to ASCII SYN character.

Stop Bits (asynchronous mode only) — Responds to one or more. Transmits 2.

833 ONLY

Block Check Characters — CRC-16, CRC-CCITT, LRC.

Synchronizing Character (SYN), (synchronous mode only) — Programmable to require one or two characters. If not programmed, defaults to ASCII SYN character.

Stop Bits (asynchronous mode only) — Programmable to 1, 1 1/2, 2.

Bit Error Rate/Block Error Rate Tests — Standard 511-bit pattern stream for 1000-bit blocks; continuous, 10⁵ or 10⁶-bit block test; stores bits in error, blocks sent, blocks in error, and sync faults.

String Search — Programmable to search for one sequence of 1, 2, or 3 characters.

Full duplex DTE simulation.

BOTH 832/833

RS-232 DCE CONNECTOR (J1405)

Inputs

Pin 3 Received Data, Pin 5 Clear to Send, Pin 6 Data Set Ready, Pin 8 Carrier Detect, Pin 15 Transmission Signal Element Timing (DCE source), Pin 17 Receiver Element Timing (DCE source) —

MARK or OFF: $-25\text{ V} \leq V$ in $\leq +0.75\text{ V}$.

SPACE or ON: $+1.5\text{ V} \leq V$ in $\leq +25\text{ V}$.

Input Impedance: $3\text{ k}\Omega \leq Z$ in $\leq 7\text{ k}\Omega$.

Pin 20 Data Terminal Ready, Pin 24 Transmit Signal Element Timing (DTE source) — MARK or OFF: $-25\text{ V} \leq V$ in $\leq -3\text{ V}$. SPACE or ON: $+3\text{ V} \leq V$ in $\leq +25\text{ V}$. Input impedance with corresponding pin in DTE connector disconnected: Pin 20 Z in $\geq 40\text{ k}\Omega$. Pin 24 Z in $\geq 100\text{ k}\Omega$.

Outputs

Pin 2 Transmitted Data, Pin 4 Request to Send —

MARK or OFF: V out $\leq -7.5\text{ V}$.

SPACE or ON: V out $\geq +7.5\text{ V}$.

With load impedance: $R_L \geq 3\text{ k}\Omega$.

Other

Pin 1 Ground — Connected to pin 1 of DTE connector.

Pin 7 Signal Ground — Connected to instrument ground.

Pins 9 thru 14, 16, 18, 19, 21 thru 23, and 25 — Connected through switches (Breakout Panel DIP switches) to their corresponding pins in the DTE connector.

RS-232 DTE CONNECTOR (J2205)

Inputs

Pin 2 Transmitted Data, Pin 4 Request to Send —

MARK or OFF: $-25\text{ V} \leq V$ in $\leq +0.75\text{ V}$.

SPACE or ON: $+1.5\text{ V} \leq V$ in $\leq +25\text{ V}$.

Input impedance: $3\text{ k}\Omega \leq Z$ in $\leq 7\text{ k}\Omega$.

Pin 20 Data Terminal Ready, Pin 24 Transmit Signal Element Timing (DTE source) — MARK or OFF: $-25\text{ V} \leq V$ in $\leq -3\text{ V}$. SPACE or ON: $+3\text{ V} \leq V$ in $\leq +25\text{ V}$. Input impedance with corresponding pin in DCE connector disconnected: Z in $\geq 100\text{ k}\Omega$.

Outputs

Pin 3 Received Data, Pin 5 Clear to Send, Pin 6 Data Set Ready, Pin 8 Carrier Detect, Pin 15 Transmission Signal Element Timing (DCE source), Pin 17 Receiver Signal Element Timing (DCE source) —

MARK or OFF: V out $\leq -7.5\text{ V}$.

SPACE or ON: V out $\geq +7.5\text{ V}$.

With load impedance: $R_L \geq 3\text{ k}\Omega$.

Other

Pin 1 Ground — Connected to pin 1 of DCE connector.

Pin 7 Signal Ground — Connected through a switch (Breakout Panel DIP switch) to instrument ground.

Pin 9 thru 14, 16, 18, 19, 21 thru 23, and 25 — Connected through switches (Breakout Panel DIP switches) to their corresponding pins in the DCE connector.

BREAKOUT PANEL

Probe —

Space: $+3\text{ V} \leq V$ in $\leq +25\text{ V}$.

Mark: $25\text{ V} \leq V$ in $\leq -3\text{ V}$.

Input Impedance: $\geq 50\text{ k}\Omega$.

Marker — MARK or OFF: $-25\text{ V} \leq V$ in $\leq -3\text{ V}$.

SPACE or ON: $+3\text{ V} \leq V$ in $\leq +25\text{ V}$ (Schmitt input).

+12 Volt Source — $+12\text{ V} \pm 1\text{ V}$ (no load). Output impedance approx $3\text{ k}\Omega$ (each pin).

DISPLAY

Buffer Content — 2 hexadecimal digits: 7-segment, LED displays.

Buffer Location — 3 decimal digits: 7-segment, LED displays.

Data Source — DCE, DTE: 2 LED indicators.

Error — Parity, Frame: 2 LED indicators.

No Trig, No Syn — 2 LED indicators.

RS-232 Control Lines — DSR, CD, CTS, RTS, DTR, and MARKER: 6 LED indicators.

Probe — Mark, Space: 2 LED indicators.

PHYSICAL CHARACTERISTICS

| Dimensions (approx) | cm | in |
|---------------------|-----------|-----------|
| Width | 33 | 13 |
| Height | 10 | 4 |
| Length | 31 | 12 |
| Weight | kg | lb |
| Net | 5 | 11 |

MEMORY

Receive buffer is 256 characters and send buffer is 255 characters. Basic instrument contains in memory a group of 7 separate standard test messages such as "THE QUICK BROWN FOX —" and the full ASCII Alphanumeric set.

There is provision in the 832/833 for installation of user defined and programmed EPROMs containing messages specific to particular tests. A total memory space of 2048 characters is available for user specification.

POWER REQUIREMENTS

Line Voltage Ranges —

115 V — 90 to 132 V.

230 V — 180 to 250 V.

Line Frequency Range — 48 to 440 Hz.

Power Consumption — ≈ 15 watts.

ENVIRONMENTAL

Temperature — Operating: 0° to $+50^\circ\text{C}$ ($+32^\circ$ to $+122^\circ\text{F}$). Nonoperating: -55° to $+75^\circ\text{C}$ (-67° to $+167^\circ\text{F}$).

Humidity — 5 cycles (120 hrs), 30° to 60°C , 95% relative humidity.

Altitude — Operating: To 4500 m (15,000 ft). Nonoperating: To 15,000 m (50,000 ft).

Vibration — Cycle the vibration frequency from 10 to 55 to 10 Hz (linear or logarithmic sweep) for a duration of 15 minutes in each major axis at a displacement of 0.64 mm (0.025 in) p-p. Dwell for 10 minutes in each major axis at any resonant frequency.

Shock — 50 g's, 1/2 sine, 11 ms duration, three shocks in each major axis for a total of 18 shocks.

INCLUDED ACCESSORIES

Both 832/833

RS-232 cable assembly (012-0815-00), jumper set (198-4006-00), power cord (161-0066-00), Y-Connector (012-0893-00) 833 only.

ORDERING INFORMATION

832 Data Comm Tester..... \$1995

INSTRUMENT OPTIONS

DATASPEED 40 ROM Option 0A..... Add \$210

IBM 3270 Exercizer ROM Option 0B..... Add \$210

Current Loop Interface Option 02..... Add \$300

High-Level Data Link Control (HDCL)

Option 03 Add \$325

OPTIONAL ACCESSORIES

Self Test Adapter — 067-0878-00..... \$100

Current Loop Pod Accessory — 015-0361-00..... \$325

Carrying Case — 016-0672-00..... \$70

ORDERING INFORMATION

833 Data Comm Tester \$2750

DATASPEED 40 ROM Option 0A Add \$210

IBM 3270 Exercizer ROM Option 0B Add \$210

Current Loop Interface Option 02 Add \$300

OPTIONAL ACCESSORIES

Self Test Adapter — 067-0878-00 \$100

Current Loop Pod Accessory — 015-0361-00 \$325

Carrying Case — 016-0672-00 \$70

830 SERIES Product Line Comparison

| | 832 | 833 | 834 |
|---|-------------------------------------|-------------------------------------|---|
| Operation Modes | | | |
| Monitor | Yes | Yes | Yes |
| DCE simulate | Yes | Yes | Yes |
| DTE simulate | No | Yes (FDX only) | Yes |
| Bit Error Rate Testing | No | 511 Pattern | Multiple Patterns* |
| Bias Distortion Test | No | No | Yes* |
| Inverted Data Capabilities | No | No | Yes* |
| Self Test | Functional | Functional | Functional & Diagnostic |
| Maximum Data Transfer Rate | | | |
| | 9.6K baud | 9.6K baud | 19.2K baud |
| Separate Transmit/Receive Rates | | | |
| | No | No | Yes* |
| Memory | | | |
| Receive buffer (characters) | 256 | 256 | 2699 |
| Send buffer (characters) | 255 | 255 | 3000 |
| User PROM (characters) | 2048 (data only) | 2048 (data only) | 16K (data or program sequence) |
| Receive buffer search | No | Yes | Yes |
| Display | | | |
| No. of characters & type | 3 address + 2 data 7 segment LED | 3 address + 2 data 7 segment LED | 12 data & 4 scratch pad 5x7 matrix flourescent |
| Operating Controls | | | |
| Operator menu | No | No | Yes |
| Programmed sequences | No | No | Yes (manual or from ROM pack) |
| Initialization | Fixed default or manual | Fixed default or manual | Fixed default, program initialization, manual |
| Programmable timeout | No | No | Yes |
| Triggering/Trapping | | | |
| Strings | 3 characters | 3 characters | 1-5 characters (non- masked) 1-25 characters (masked) |
| Errors | No | No | Yes |
| Events | No | No | Yes |
| Error Check | | | |
| Parity check | Yes | Yes | Yes |
| Frame check | Yes | Yes | Yes |
| Block check function | | | |
| Generate | No | Yes | Yes |
| Check | No | Yes | Yes |
| Type | None | LRC, CRC, CRC 16, CRC-CCITT | LRC, CRC-16, CRC-CCITT,CCC-6* |
| Auto CRC Insertions | No | No | Yes* |
| Programmable: | | | |
| Stored programs | No | No | Yes |
| Stored messages | No | No | 99 steps(extendable through overlays*) |
| Recallable keystroke sequences | 255 characters | 255 characters | 3000 characters |
| Counters | No | No | Yes |
| | No | No | Yes* |
| Optional Interfaces | | | |
| Current Loop | Yes | Yes | Yes |
| RS449 (RS422, RS423) | No | No | Yes |
| MIL STD 188C | No | No | Yes |
| Codes | | | |
| Standard | Hex | Hex | EBCDIC, ASCII, HEX |
| Optional* | None | None | Correspondence, Baudot, Sabre, Reverse Hex, User Defined |
| Data Communications Environments | | | |
| Asynchronous | Monitor/Simulate | Monitor/Simulate | Monitor/Simulate |
| Bisynchronous | Monitor/ Limited Simulate | Monitor/ Limited Simulate | Monitor/Simulate |
| HDLC/SDLC | Monitor | Monitor | Monitor/Simulate* |
| X.25 | No | No | Monitor/Siimulate* |
| PARS/IPARS | No | No | Monitor/Simulate* |
| Net Weight | | | |
| | 11 lb | 11.5 lb | 12 lb |
| Price | | | |
| | \$1995 | \$2750 | \$3990 |

*Provided or enhanced with appropriate ROM pack.

851

Designed for Digital Field Service Applications

Small and Lightweight

The 851 Digital Tester is an easy-to-operate first-line service tool used to troubleshoot and maintain a wide range of digital equipment.

With this portable digital tester (only, 6 kg, 13 lb), a first-line service engineer can make many of the same measurements that now require an oscilloscope, DMM, counter, timer, logic probe, thermometer and special purpose test equipment.

One knob lets you dial 22 functions to perform a wide variety of tests and measurements. Eleven functions measure timing, two register plus and minus peak voltages, three carry out DMM measurements through separate leads and one reads line voltage at the outlet. Another function allows you to take temperature readings with an optional temperature probe. The 851 also measures its four input thresholds to adjust to the logic levels of the equipment being serviced.

All functions are completely autoranging and the indicator lights tell you exactly what range is being used.

CHARACTERISTICS

INPUTS

(ACV, DCV, Ω)

Resistance and Capacitance — 10 MΩ ±1% and ≈100 pF. Red to black terminal. (Volts only.)

Max Safe Input Voltage — ±500 V (peak) ACV/DCV (≤1 kHz)

Resistance

Ranges — 200 Ω, 2 kΩ, 20 kΩ, 200 kΩ, 2 MΩ, 20 MΩ, and 50 MΩ.

AC VOLTS

(Average responding RMS calibrated for sine wave.)

Ranges — 2 V, 20 V, 200 V, and 350 V.

Accuracy

2 V and 20 V:
±0.5% or reading ±4 counts, 40 Hz to 1 kHz.
±2% of reading ±4 counts, 1 kHz to 25 kHz.
>9% full scale.

200 V and 350 V:
±0.5% of reading ±4 counts, 40 Hz to 1 kHz.

Extended temperature range: add ±0.2%.

DC VOLTS

Ranges — 2 V, 20 V, 200 V, and 500 V.

Accuracy —
2 V, 20 V and 200 V: ±0.1% of reading ±3 counts.
500 V: ±0.15% of reading ±3 counts.
Extended temperature range: add ±0.05%.

LINE VOLTAGE

Range — 90 to 132 V and 180 to 250 V.

Accuracy — ±3% of reading.

TEMPERATURE

Range — -55° to +150°C.

Accuracy — ±2°C (0.01° resolution). Extended temperature range: add ±1°C.

INPUTS

(3 probes; one for each channel A, B, C.)

Resistance and Capacitance — 10 MΩ and ≈12 pF.

Max Safe Input Voltage — ±500 V at probe tip (≤50 kHz).



Threshold Levels — Variable (4 controls) range: ±30 V; setability ±10 mV.

TTL (nominal, in detent position) — Input A LO + 0.7 V; HI + 2.1 V; Input B and C + 1.4 V.

Input Filter (Narrow pulse rejection) — Max input rep rate for pulse rejection = 20 MHz.

Range — Off and 50 ns ±20% to >300 ns. Channel to channel delay mismatch: <100% of setting.

POSITIVE AND NEGATIVE

PEAK VOLTS

Range — ±30 V.

Accuracy — ±2% of reading ±3% of p-p signal ±90 mV. Max time between recurrent peaks, 25 ms. Peak amplitude must be maintained for at least 25 ns. Extended temperature range: add ±1% of reading ±1% of p-p signal ±10 mV.

FREQUENCY

Ranges — 100 kHz (1 Hz resolution), 1 MHz, 10 MHz, and 35 MHz.

Accuracy — ±0.005% of reading ±1 count.

TIME MEASUREMENTS

(Period, pulse width, transition time, time interval, and coincidence time.)

Ranges — 1 ms (10 ns resolution), 10 ms, 100 ms, 1 s, and 10 s.

Minimum Time Interval — 20 ns.

Accuracy — ±0.005% of reading ±1 count ± Trigger Error.

COUNTING

(Totalize, frequency ratio, events count, and transitions count.)

Range — 0 to 99,999.

Max Input Frequency — 35 MHz (except 17.5 MHz for transition counting).

Accuracy — ±1 count, ±A Input event or transition frequency multiplied by the Time Interval Trigger Error.

DUTY FACTOR

Range — 0 to 100%.

Input Freq Range — 40 Hz to 10 MHz.

Min Pulse Width (HI and LO portions) — 50 ns.

READOUT

Type — 5 digits, fully buffered 7 segment, 0.5 in LEDs.

Polarity Indication — + for positive readings, - for negative readings.

Overrange Indication — Display flashes.

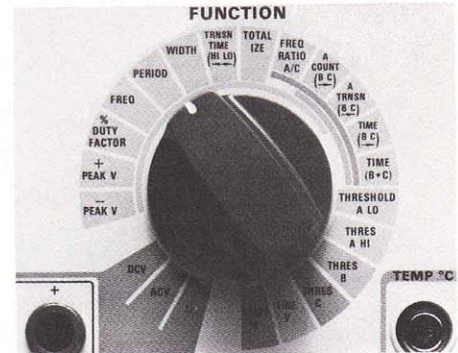

Range Indicators — LEDs show function ranges in Ω, kΩ, MΩ, MHz, kHz, ms, μs and V.

Logic State Indicators — Red, yellow, and green LEDs show valid and invalid logic state inputs for CH A. Red and green LEDs show logic states above or below the threshold set for CH B and C. Any state change indication is sustained long enough to be visible.

Threshold Lock Indicator (LO > HI) — Red LED indicates when CH A LO and HI thresholds are locked together (LO threshold setting is higher than the HI setting).

PHYSICAL CHARACTERISTICS

| Dimensions (approx) | cm | in |
|---------------------|-----------|-----------|
| Width | 33 | 13 |
| Height | 31 | 12 |
| Depth | 18 | 7 |
| Weight | kg | lb |
| Net | 6 | 13 |

POWER REQUIREMENTS

Line Voltage Range — 90 to 132 V or 180 to 250 V.

Frequency — 48 Hz to 440 Hz.

Power Consumption — 57 watts max.

ENVIRONMENTAL CAPABILITIES

Ambient Temperature — Operating: +15°C to +40°C.

Nonoperating: -40°C to +75°C. Extended operating range: +5°C to +50°C.

Altitude — Operating: to 10,000 ft. Nonoperating: to 35,000 ft.

Vibration — Operating: 15 minutes along each of the 3 major axes, 0.06 cm (0.025 in) p-p displacement (4 g's at 55 Hz) 10 to 55 to 10 Hz in 1 minute cycles. After cycle vibration in each axis, hold frequency steady at 55 Hz for 10 minutes. All major resonances must be above 55 Hz.

Humidity — To 90% at 30°C Tektronix Test Method #1 90% relative humidity at 30°C for 4 hours.

Shock — Two shocks at 30 g's, 1/2 sine, 11 ms duration, each direction along each major axis. Total of 12 shocks.

EMC — Reference Mil Standard 461A-462 susceptibility as specified. Conducted emission, relax 10 dB. Radiated emission, relax 15 dB <100 MHz and relax 25 dB ≥100 MHz.

INCLUDED ACCESSORIES

Three signal probes (010-0280-00), two DMM probes (012-0732-00).

ORDERING INFORMATION

851 Digital Tester \$2920

INSTRUMENT OPTION

Option 01 (with temperature probe) Add \$160

OPTIONAL ACCESSORIES

Temperature Probe — 010-6430-00 \$180

Rain Jacket — 016-0639-00 \$15

SEMICONDUCTOR TEST SYSTEMS

CONTENTS

| | |
|--|----|
| S-3275 Automated Semiconductor Test System | 37 |
| S-3250 Automated Semiconductor Test System | 38 |
| S-3270 Automated Semiconductor Test System | 39 |
| S-3280 Automated ECL Test System | 40 |

Need to test complex devices?

Tektronix has the solution.

At Tektronix, we've looked to the future to see what test problems the new device technology will create. Problems like increased complexity, faster speeds and higher pin count are only a few which continue to shape the rapidly changing device technologies. We've created a complete line of automated test systems to be ready to solve the problems of today...and tomorrow.

The S-3200 Series can solve your device testing problems

Tektronix is ready now to provide the expertise, people, systems and software to tackle your existing test problems as well as the future problems you'll encounter. New or unusual device parameters do not present an impossible task. The versatility that's built into every S-3200 system is based upon field proven hardware and software that gets the job done.

Only one software language to learn... TEKTEST

Each system uses the same highly advanced software...TEKTEST. Using TEKTEST, the test engineer can easily and quickly generate, edit, and debug programs for device testing or characterization and then transfer these programs from one system to the other. And, using our foreground-background capability, up to four users can

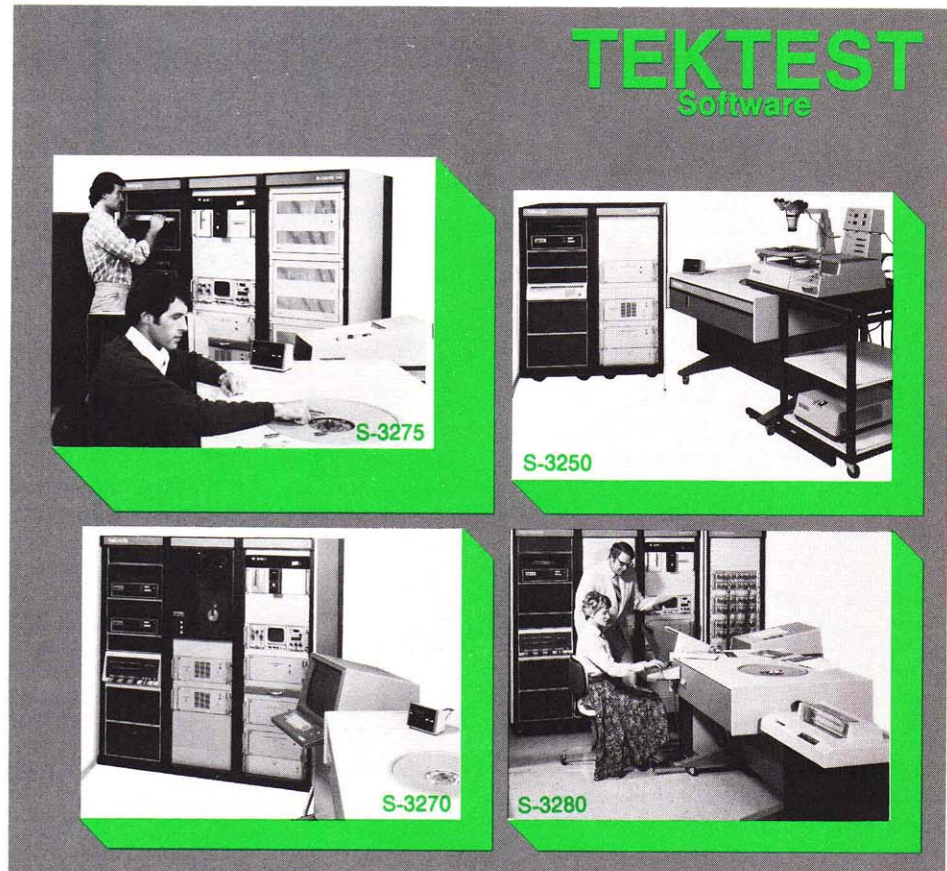

be programming or compiling data in the background while testing occurs uninterrupted in the foreground. Also, Terminal Control Mode, our powerful debug tool, gives the test engineer total control of the test problem. Ease of operation simplifies testing. And, all the systems feature highly sophisticated data reduction and graphics, making the test results manageable and easily understood.

New devices present new challenges

New devices such as codecs, linears, and the ever-changing digital ICs present continual evolving complexity in device testing. And, the increasing amount of both analog and digital on the same chip continues to push technology. Tektronix offers the analog and digital capability to meet these

unique test requirements. In fact, captive manufacturers of devices buy Tektronix systems for this advantage. Tektronix, also a captive device manufacturer, has been testing their own hybrids over the years, and this expertise provides an in-depth understanding in device testing.

At Tektronix, we've built on our past experience and knowledge about device testing to create a total, compatible line of LSI/VLSI test systems that can help solve your test problems — now and in the future.

S-3275 **NEW**

"Superior hardware and software to meet the challenge of LSI/VLSI memory device technology"

Independent I/O Control on a Cycle-by-cycle Basis at Each Pin

16 Programmable Driver/compare Phases

16 Programmable Timing Sets Each Available on a Cycle-by-cycle Basis (Split-cycle)

Full Functional Data (Force, Inhibit, Compare, Mask) to all Pin Electronics Cards at 20 MHz Test Speed

Versatile Driver Formats

Test Devices with Up to 128 Pins

Single-shot Timing

Advanced Graphics and Data Reduction

Uses TEKTEST III[®], a Device-oriented Test Language with Networking Capability

Up to 64 D70 Pin Electronics Cards

Each with:
Independent I and O Pins
Independent drive and compare levels
4 k shift register pattern memory
Dc and 50 Ω access to I and/or O
Independent I/O switching control

16 Phase Clock Generator

125 ps resolution on clock pulse width and edges
Cycle period — 500 Hz to 20 MHz in 2 ranges
Cycles may be generated in a free-running mode or by external synchronization to the DUT, and the mode may be switched on a cycle-by-cycle basis by the Pattern Controller
Clock Phases in any given set may be programmed to be always on or always off
Up to 20 MHz maximum clock rate

Memory Pattern Processor

Pattern Sequencing
Utilizes loops, subroutines, and list pointers to control program flow
Branches on condition and interrupts
Subroutines and loops with single or multiple pattern vectors may be nested up to 15 deep
Interrupts from ERROR conditions, a programmed time interval or CYCLE count, and the system controller may be utilized to modify program flow

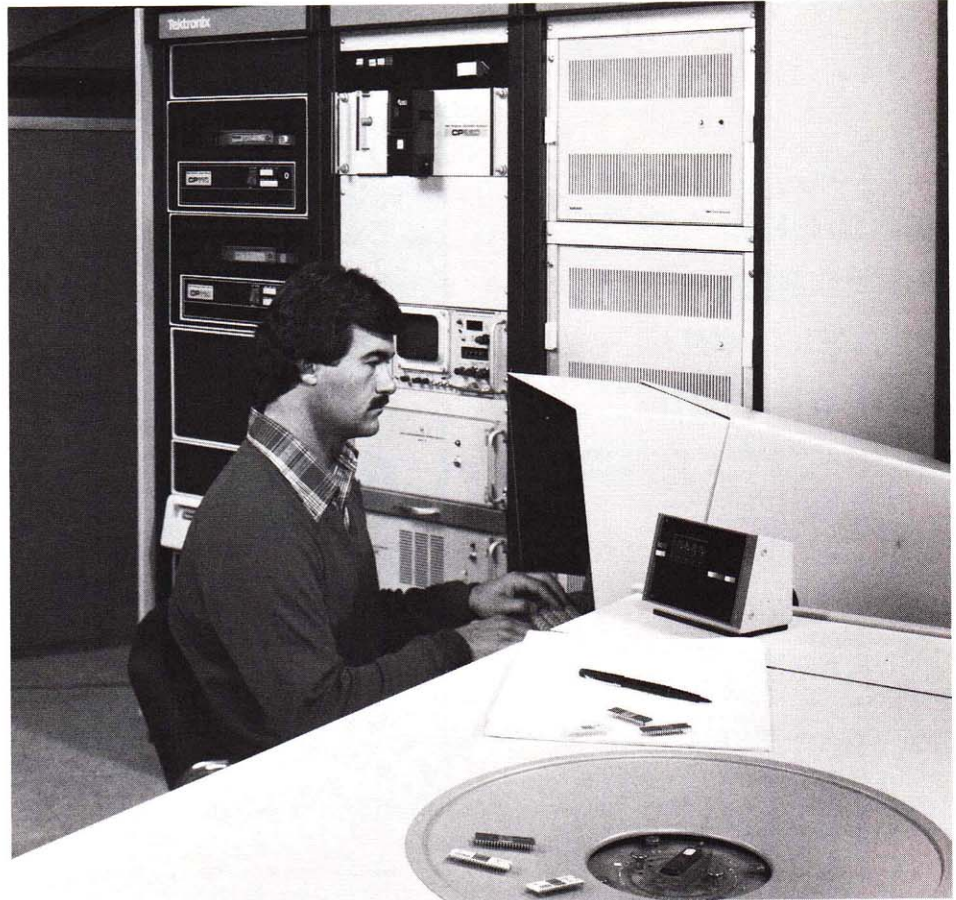

Algorithmic Pattern Generator

Separate, but identical, X and Y address generators — each 12 bits wide
Each generator contains a 16 word register file plus 12 bit maximum address, minimum address, and base address registers
The address generator output is computed in an ALU, using an instruction word as operands
X and Y addresses may be scrambled by the contents of the Topological Memory (12 bits by 4k words)
The data generator produces 16 FORCE and 16 COMPARE bits
A control (Z-axis) generator is used to provide forcing data for R/W, chip selects, etc.
Normal stored pattern memory data or APG data may be selected each cycle at full clock rate

Dc Parametric Stimulus System

Force voltage 0 to ±100 V in 10 mV increments
Optional force voltage 0 to ±10 V in 1 mV increments
6 DUT power supplies with programmable current limit and Kelvin sensing
Force current from 0 to ±200 mA in 1 μA increments
Optional force current ±1 nA full scale

Dc Parametric Measurement System

Differential or single ended voltage measurements
Measure voltage range from ±100 mV full scale to ±100 V full scale
Measure current range from ±100 nA Full scale to ±450 mA full scale
Optional current measurement range from ±100 pA to ±100 nA full scale

Single-Shot Time Measurement System

Triggerable to allow functional preconditioning
Uses functional comparators for strobing and level detection
50 ps resolution (100 ns range)

50 Ω Switching Matrix

4 channels standard
High fidelity analog stimulus path to DUT
High fidelity analog measurement path from DUT, direct or buffered

Foreground/Background Disk Operating System

Floating point hardware for calculating speed
Multi-user environment for program development and data analysis
TEKTEST III high level software language
Interactive Program Debugging Mode (PDM)
Terminal Control Mode (TCM)
Graphics data capability in user programs
Complete utility program library

Networking, Operating System Software

Enables multiple test systems to communicate with a host computer, intermediate processor, or among themselves;
Allows more efficient operation of the test systems due to the sharing of resources; and
Provides error-free transfer of data for storage or processing.

Full User Support Program

VERDICT system diagnostic and verification package
RECAL computer guided system recalibration package
Spares kits for system items and options
90 days on-site warranty (parts and labor)
Applications training credits
Maintenance training credits

Optional Waveform Digitizer

2 channels simultaneously digitized
2 mV per division to 25 V per division
100 ps per division to 500 ms per division
Triggerable with system clock or external instruments
Software for signal averaging, pulse analysis, Fast Fourier Transform, harmonic distortion, etc.
Vertical and horizontal internal references

Optional Instrumentation

IEEE-488 bus interface
Digital voltmeters
Digital counters
Pulse generators
Waveform synthesizers

S-3250

TEKTEST

**“Fast,
efficient,
accurate,
production
test system.”**

Interfaces with Popular Handlers and Probers

20 MHz Clock Rate

High Through-put

Minimum Operator Interface

Fast Change-over

Uses TEKTEST III®

Easy to Program and Edit

**Maximum System Run-time, Since Program-
ming can Occur During Testing.**



Up to 64 D70 Pin Electronics Cards

Each with:
Independent I and O pins
Independent drive and compare levels
4 k shift register pattern memory
Dc and 50 Ω access to I and/or O
Independent I/O switching control

7 Phase Clock Generator

Free running or externally synchronized modes
1 ns positioning resolution of all edges
Up to 20 MHz maximum clock rate
Optional 14 phase clock

Dc Parametric Stimulus System

Force voltage 0 to ± 100 V in 10 mV increments
Optional force voltage = 0 to ± 10 V in 1 mV increments
6 DUT power supplies with programmable current limit and Kelvin sensing
Force current and 0 to ± 200 mA in 1 μA increments
Optional force current ± 1 nA full scale

50 Ω Switching Matrix

2 channels standard, 4 channels optional
High fidelity analog stimulus path to DUT
High fidelity analog measurement path from DUT, direct or buffered

Dc Parametric Measurement System

Differential or single-ended voltage measurements
Measure voltage range from ± 100 mV full scale to ± 100 V full scale
Measure current range from ± 100 nA full scale to ± 450 mA full scale
Optional current measurement range from ± 100 pA to ± 100 nA full scale

Foreground/Background Disk Operating System

Floating point hardware for calculating speed
Multi-user environment for program development and data analysis
TEKTEST III High level software language
Interactive Program Debugging Mode (PDM)
Terminal Control Mode (TCM)
Graphics data capability in user programs
Complete utility program library

Full User Support Program

VERDICT system diagnostic and verification package
RECAL computer guided system recalibration package
Spares kits for system items and options
90 days on-site warranty (parts and labor)
Applications training
Maintenance training

Optional Single-Shot Time Measurement System

Triggerable to allow functional preconditioning
Uses functional comparators for strobing and level detection
50 ps resolution (100 ns range)

Optional Pattern Random Access Memory (PRAM)

1 k or 4 k memory depth
32 bits control and 64 bits pattern data
Match mode (start when ready)
Pattern source selection (S/R or PRAM) on-the-fly
Loop and subroutine capability for pattern compression

Optional Instrumentation

IEEE Bus interface
Digital voltmeters
Digital counters
Pulse generators
Waveform synthesizers

Optional Waveform Digitizer

2 channels simultaneously digitized
2 mV per division to 25 V per division
100 ps per division to 500 ms per division
Triggerable with system clock or external instruments
Software for signal averaging, pulse analysis, Fast Fourier Transform, harmonic distortion, etc.
Vertical and horizontal internal references

Optional Memory Pattern Generator

Independent X and Y address generators, up to 12 bits each
Data generator up to 32 bits
Algorithmically programmed
Stores error addresses as test proceeds at clock rate

S-3270

TEKTEST

“Field proven device characterization/production test system.”

- Uninterrupted Error Storage at 20 MHz
- Multiple Pattern Sources
- Versatile Driver Formats
- 14 Programmable Channels of Timing Information
- Test Devices with Up to 128 Pins
- Single-shot Timing
- Advanced Graphics and Data Reduction
- Uses TEKTEST III®, a Device-oriented Test Language
- Easy to Program and Edit
- True Foreground/Background Timesharing

- Up to 64 D70 Pin Electronics Cards**
Each with:
Independent I and O Pins
Independent drive and compare levels
4 k shift register pattern memory
Dc and 50 Ω access to I and/or O
Independent I/O switching control
- 14 Phase Clock Generator**
Free running or externally synchronized modes
1 ns positioning of all edges
Up to 20 MHz maximum clock rate
- Pattern Random Access Memory (PRAM)**
1 k memory depth (4 k optional)
32 bits control and 64 bits pattern data
Match mode (start when ready)
Pattern source selection (S/R or PRAM) on-the-fly
Loop and subroutine capability for pattern compression
- Dc Parametric Stimulus System**
Force voltage 0 to ±100 V in 10 mV increments
Optional force voltage 0 to ±10 V in 1 mV increments
6 DUT power supplies with programmable current limit and Kelvin sensing
Force current from 0 to ±200 mA in 1 μA increments
Optional force current ±1 nA full scale



- Dc Parametric Measurement System**
Differential or single ended voltage measurements
Measure voltage range from ±100 mV full scale to ±100 V full scale
Measure current range from ±100 nA full scale to ±450 mA full scale
Optional current measurement range from ±100 pA to ±100 nA full scale
- Single-Shot Time Measurement System**
Triggerable to allow functional preconditioning
Uses functional comparators for strobing and level detection
50 ps resolution (100 ns range)
- 50 Ω Switching Matrix**
4 channels standard
High fidelity analog stimulus path to DUT
High fidelity analog measurement path from DUT, direct or buffered
- Foreground/Background Disk Operating System**
Floating point hardware for calculating speed
Multi-user environment for program development and data analysis
TEKTEST III high level software language
Interactive Program Debugging Mode (PDM)
Terminal Control Mode (TCM)
Graphics data capability in user programs
Complete utility program library

- Full User Support Program**
VERDICT system diagnostic and verification package
RECAL computer guided system recalibration package
Spares kits for system items and options
90 days on-site warranty (parts and labor)
Applications training credits
Maintenance training credits
- Optional Waveform Digitizer**
2 channels simultaneously digitized
2 mV per division to 25 V per division
100 ps per division to 500 ms per division
Triggerable with system clock or external instruments
Software for signal averaging, pulse analysis, Fast Fourier Transform, harmonic distortion, etc.
Vertical and horizontal internal references
- Optional Memory Pattern Generator**
Independent X and Y address generators, up to 12 bits each
Data generator up to 32 bits
Algorithmically programmed
Stores error addresses as test proceeds at clock rate
- Optional Instrumentation**
IEEE-488 bus interface
Digital voltmeters
Digital counters
Pulse generators
Waveform synthesizers

S-3280

**"Ultra
high-speed
logic device
testing with
superb
accuracy."**

100 k ECL Testing

Precision Fixturing

Sub-nanosecond Measurements

Full Graphics and Data Reduction Package

High Speed Drivers

Sampling for Waveform Analysis

Uses TEKTEST III*

Simple to Program and Edit

Tests High Speed Logic

CML Capability



TYPICAL DRIVER WAVEFORM

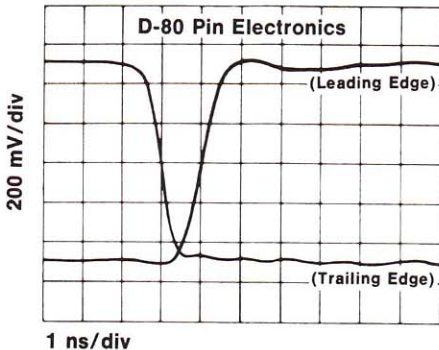

Up to 64 D80 Pin Electronics Cards

Each with:
Sub-nanosecond driver
High accuracy 50 Ω comparators
Independent drive and compare levels
4 k local memory pattern
Dc and 50 Ω access to I and/or O
Independent I/O switching control

7 Phase Clock Generator

Free running or externally synchronized modes
1 ns resolution of all edges
Up to 20 MHz maximum clock rate

Pattern Random Access Memory (PRAM)

1 k memory depth (4 k optional)
32 bits control and 64 bits pattern data
Match mode (start when ready)
Pattern source selection (local memory or PRAM) on-the-fly
Loop and subroutine capability for pattern compression

Dc Parametric Stimulus System

Force voltage from 0 V to ± 40 V in 10 mV steps
Force voltage from 0 V to ± 10 V in 1 mV steps
6 DUT high resolution power supplies with programmable current limit and Kelvin sensing
Force current 0 A to ± 200 mA in 1 μ A steps
Optional CF-1 force current from 0 A to 200 μ A; 0.05% resolution

Dc Parametric Measurement System

Differential or single ended voltage measurements
Measure voltage range from ± 200 mV full scale to ± 40 V full scale
Measure current range from ± 100 nA full scale to ± 450 mA full scale
Optional current measurement range from ± 100 pA to ± 100 nA full scale

Single-Shot Time Measurement System

Triggerable to allow functional preconditioning
Uses functional comparators for strobing and level detection
50 ps resolution (100 ns range)

50 Ω Switching Matrix

2 channels for external access to/from each DUT pin under programmable control
High fidelity analog stimulus path to DUT
High fidelity analog measurement path from DUT

Foreground/Background Disk Operating System

TEKTEST III high level software language
Multi-user environment for program development and data analysis
Interactive Program Debugging Mode (PDM)
Terminal Control Mode (TCM)
Floating point hardware for calculating speed
Graphics data capability in user programs
Complete utility program library

Full User Support Program

VERDICT system diagnostic verification package
RECAL computer guided system recalibration package
Spares parts kits available for system items and options
90 days on-site warranty (parts and labor)
Applications training
Maintenance training

Optional Waveform Digitizer

2 channels simultaneously digitized
2 mV per division to 200 mV per division
100 ps per division to 500 ms per division
Triggerable from system clock or external instruments
Software for signal averaging, pulse analysis, Fast Fourier Transform (FFT), harmonic distortion, etc.
Vertical and horizontal internal references

Optional Memory Pattern Generator

Independent X and Y address generators, up to 12 bits each
Data generator up to 32 bits
Algorithmically programmed
Stores error addresses as test proceeds at clock rate

Optional Instrumentation

IEEE-488 bus interface Pulse generators
Digital voltmeters Waveform synthesizers
Digital counters

100 k Series ECL Fixturing

Accurate measurements on 100 k ECL devices

Standard ECL Fixturing

Individually wired for specific device type
Accepts Zero Insertion Force (ZIF) sockets

Optional 50 Ω Prober Interface

Accurate measurement on ECL devices at wafer level
50 Ω impedance maintained up to prober pins

Optional Current Mode Logic (CML) Test Capability

Graphics

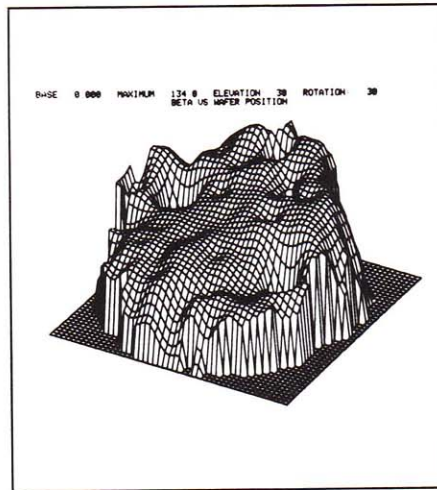
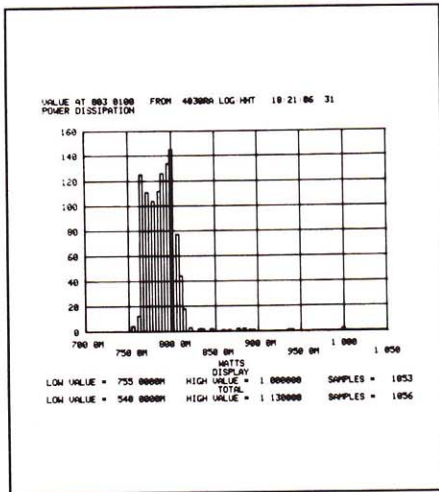
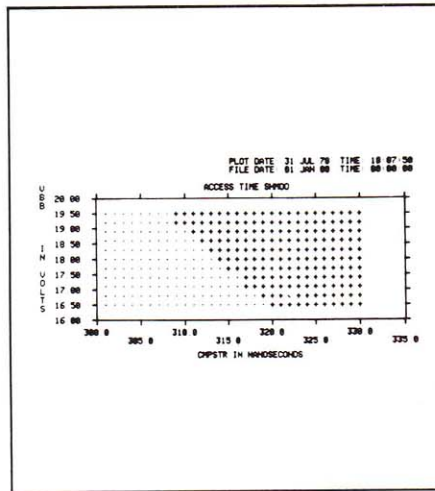
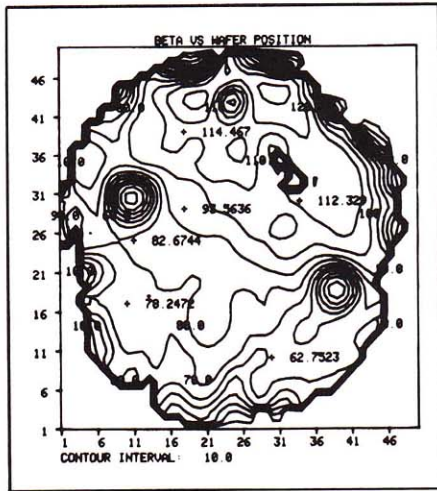

The language of these systems is TEKTEST III. It's a device-oriented language, and is easy to read and understand since it's very close to English. The architecture of the system was designed so that programming, editing and debugging all use TEKTEST III. When making corrections in a program, there is no need to use a "bridge" language between the source language and the machine language. Everything is written in TEKTEST III. This capability, which we call Terminal Control Mode, gives the test engineer total control of the program. When editing a program during the test, the test engineer can hold power to the device, make the change, and continue the test. There's no need to re-sequence the program. And, since

the systems also feature true foreground/background timesharing, up to four test engineers can be using terminals that can be interfaced to the system, and the system will continue to test devices without any through-put loss. Terminal Control Mode and true foreground/background make the S-3200s simple and fast to program and edit.

The more complex a device, the more information you need about that device. But with complexity can come confusion...unless your test system makes the picture clearer.

The S-3200 Series systems provides you with the graphics capability to reduce testing data to manageable, usable form.

Training & Support



When you purchase your S-3200 system, we'll train your test engineers for you. We'll give you plenty of documentation to give your engineers continuous support. We'll show them how to get the most out of this advanced software system, and we'll show them how to save time on the system. When future testing problems get really tough—and they will—you'll have engineers who know how to cut your test time by using the S-3200 systems.

Tektronix offers basic and advanced training classes in both programming and maintenance of the S-3200 Series of Semiconductor Test Systems. For further training information, contact your local Sales Office or request a copy of the Tektronix Customer Training Catalog on the return card.

**Serious
about reliability?
Then you need
to know about
Tektronix
test systems.**

At Tektronix, new product designers team up with specialists in IC technology and testing known as Component Evaluation Engineers. Using their combined expertise, the team compiles information on the devices that seem to fit the application and then narrow the list to a few good candidates. Now, Component Evaluation Engineers begin their most important function; thoroughly evaluating the performance and reliability of each candidate device.

The evaluation process begins by investigating those device parameters and functions most critical to the intended application. This sometimes leads to a complete device characterization, a process that requires exhaustive testing.

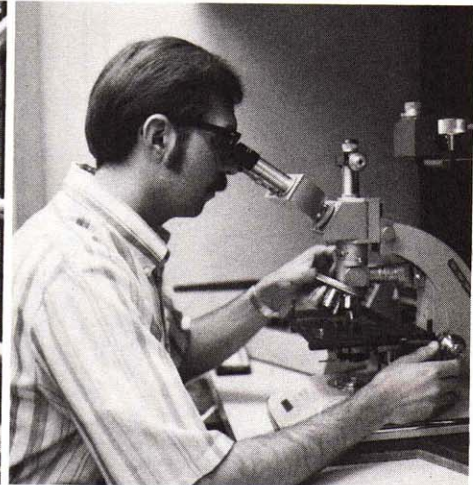
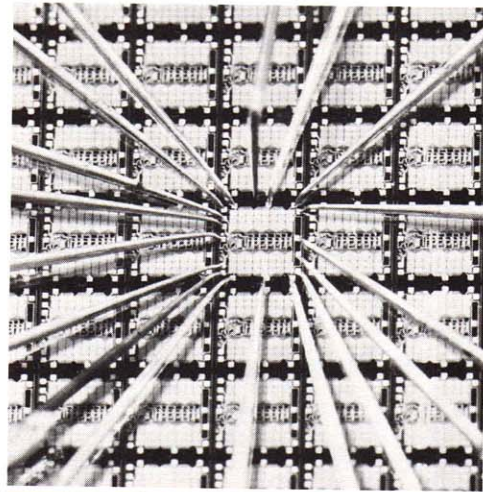

When an IC is characterized, every measurable parameter and function is tested, actual limits of performance are determined, and then device behaviour is documented for all the various sets of input conditions in all their combinations and permutations. That's a lot of testing and it can quickly build mountains of test data. A system that performs accurate and reliable tests is not enough. The Component Evaluation Engineer must also have the tools to reduce the data mass into a usable form. For device characterization, the engineer needs a combination general purpose IC test system and a data processing system — a totally integrated package that both acquires and processes test and measurement data.

Tektronix Component Evaluation Engineers find all the qualities described above in TEKTRONIX S-3200 Series semiconductor test systems. These systems are used for device characterization, field failure analysis, IC process evaluation, and incoming inspection.

Tektronix LSI/VLSI test systems are used by the world's leading telecommunications companies, aerospace contractors, computer manufacturers, semiconductor manufacturers, and by the military. Serious about reliability? Then you should know about Tektronix test systems.

For more information about the S-3200 semiconductor test systems, contact the Test Systems Specialists located in the following offices:

Portland, OR

Los Angeles, CA

Boston, MA

Philadelphia, PA

Woodbridge, NJ

St. Paul, MN

Tektronix U.K., Ltd.
Harpندن, England

Tektronix
Orsay, France

Tektronix AB
Solna, Sweden

Tektronix Holland N.,V.
Badhoevedorp, The Netherlands

Tektronix GmbH,
Köln, Germany

Tektronix SpA
Milano, Italy

Tektronix International A.G.
Zug, Switzerland

Sony/Tektronix Corporation
Tokyo, Japan

Tektronix Canada Inc.
Montreal, Canada

Tektronix Europe B.V.
Amstelveen, The Netherlands

LOGIC ANALYZERS

CONTENTS

| | |
|----------------------------------|----|
| Intro to Logic Analysis | 44 |
| DAS Products | 47 |
| 308 Data Analyzer | 56 |
| 7D02 Logic Analyzer | 58 |
| Personality Modules | 60 |
| 7D01 Logic Analyzer | 64 |
| Logic Analyzer Accessories | 66 |



DAS 9100 Digital Analysis System

132 state-of-the-art logic analyzers in one. Now you can have a single logic analysis system that is configurable, affordable and easy-to-use. The new DAS 9100 contains your selected configuration of acquisition and pattern generation modules, allowing you up to 104 input channels, up to 80 pattern generation channels, up to 330 MHz synchronous acquisition and up to 660 MHz asynchronous acquisition!

Tektronix logic analyzers provide you with the unprecedented speed and versatility of the DAS 9100, the microprocessor analysis capability of the 7D02 and a combination of features in the portable 308 Data Analyzer. You'll find that a Tektronix logic analyzer can save you time and money.

Companion instruments include the 7D11 Digital Delay for 7000 Series Oscilloscopes (page 195), the DD 501 Digital Delay and WR 501 Word Recognizer for TM 500 Series (page 267), and the A6701 18-Bit Word Recognizer (page 348).

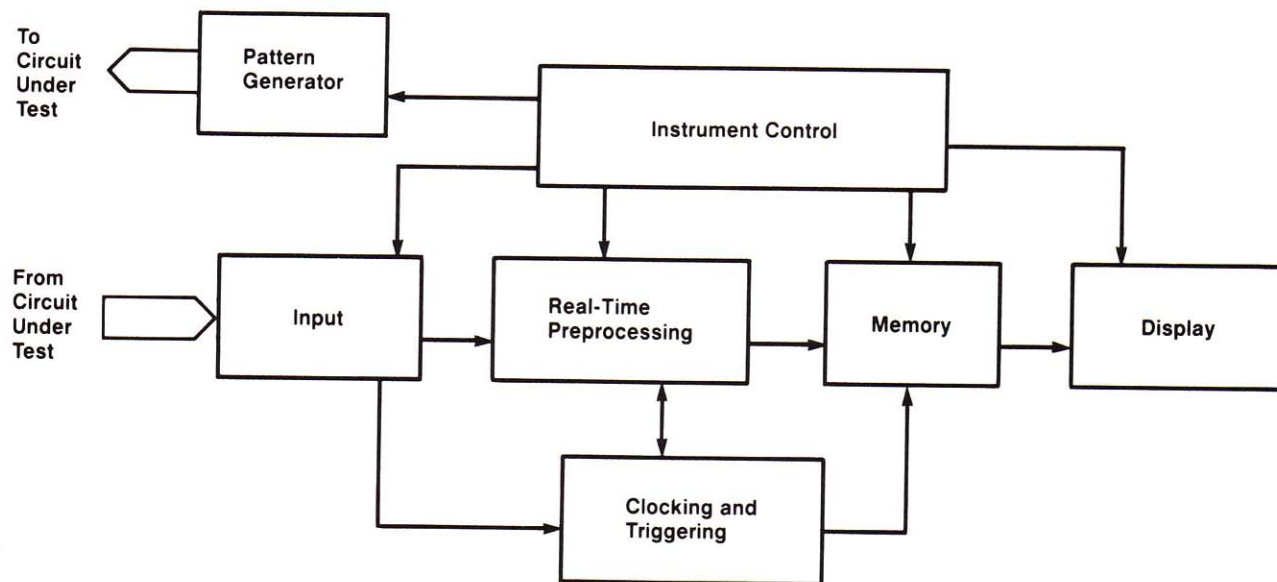

Figure 1. Logic Analyzer Block Diagram

Tektronix offers a broad range of logic analyzers, for use in design, manufacturing and service. This section of the catalog includes descriptions of these products and appropriate accessories.

Although the products differ somewhat, depending upon the specific applications for which they were designed, there are some basic architectural components of logic analysis described below.

Also we have provided a selection guide to help you locate the best set of features for your specific application.

WHY LOGIC ANALYZERS?

As electronic designers have moved from primarily analog designs to circuit designs with many digital signals, the requirements for test and measurement equipment have also changed. For digital circuits the logic analyzer has assumed a role similar to that of the oscilloscope for analog circuits. Like the scope it is a highly flexible instrument which can be connected to many different circuit points relatively easily, and it provides a clear visual display for the user.

Logic analyzers come in a variety of sizes and shapes to fulfill different requirements. There are portable, light-weight logic analyzers for field service and larger, more versatile benchtop units for use in laboratories and manufacturing areas.

The logic analyzer is continuing to evolve as new applications are identified and new features are required. As you can see from reviewing the Tektronix logic analyzer descriptions, we are committed to providing you outstanding value in the form of performance today and flexibility for the future.

ARCHITECTURE OF LOGIC ANALYZERS

Now let's look at the basic parts of a logic analyzer, as shown in figure 1. There are six main sections in conventional analyzers: input, real-time preprocessing, memory, clocking and triggering, display, and control. In the new DAS 9100 Tektronix has introduced a seventh basic section: pattern generation. Let's consider the requirements of each section.

Input

Today logic analyzers have from 8 to more than 100 parallel inputs. Typically the inputs are grouped in 8 or 16 channels per probe. The threshold voltage for the inputs is variable to allow for the wide variety of logic devices available. Each pod also includes an external clock input and/or a qualifier input, as well as ground reference lines.

Because of the special needs for various signal types, a variety of probe and accessory hardware has been developed. For very high speed signals, short leads are connected to hybrid input circuits for maximum signal fidelity. To analyze complex parts such as microprocessors, personality modules monitor the device and decode the binary patterns into meaningful mnemonics.

Real-Time Preprocessing

Because of the large amount of data in a digital system it is often necessary to preprocess the data. Clock qualification is the process of sorting data in real time based on the state of a control signal. Clock qualification sorts the data according to the time relationships to other bus signals. Data qualification is the process of sorting the data in real time based on the content of the data. Clock and data qualification increase the effective size of the acquisition memory and reduce analysis time. Personality modules often contain hardware to synthesize clocks, predict instruction fetches and decode control lines as well.

Memory

Logic analyzers may have two separate memories. The acquisition memory stores the data acquired from the circuit under test. Data is acquired and loaded into memory continuously, writing over previous data until a trigger event terminates the acquisition.

Reference memory is used to store a pattern for comparison. Such a pattern could either be acquired from a circuit operating properly or from an off-line source such as a simulator. When the contents of the acquisition memory are compared with the contents of reference memory, the differences are highlighted to enable the operator to see the errors easily.

Clocking And Triggering

The clocking and triggering area contains word recognizers and qualifiers which define the trigger event. The trigger event stops the data acquisition and serves as a reference point in the acquired data. This part of the analyzer also contains circuitry to clock the data acquisition. In logic analyzer terminology there are two modes of clocking: synchronous and asynchronous. In synchronous mode the analyzer is clocked from the circuit under test. Since in most digital systems today events in the circuit are driven by a system clock, the logic analyzer must also be able to use the system clock in order to know when to detect events. In asynchronous mode the analyzer clock is provided by the analyzer, so there is no synchronization (except the trigger event) with the circuit under test. Asynchronous clocking allows the logic analyzer to sample the data at faster rates than the system data rate and thereby provide time resolution of events occurring faster than the system clock rate. Synchronous clocking is usually used for watching state flow related to software. Asynchronous clocking is usually used to acquire hardware timing information.

There are four types of word recognition: simple, sequential, nested, and non-sequential.

Simple word recognition is the ability to recognize a single event defined by a word made up of selected input channels. For example, a 64 channel logic analyzer can have a word recognizer register of up to 64 bits which describe an event.

Sequential word recognition is the natural extension of simple word recognition. Simple events are combined sequentially to define a compound event. For example, if you expect events A, B, and C to occur in that order, you can set the trigger to look for a valid output from word recognizer A, followed by a valid output from word recognizer B, followed by a valid output from word recognizer C to trigger and end the acquisition. The trigger will occur only after all 3 events have occurred in the proper order.

Nested word recognition introduces the ability to monitor conditional branching. For example, event A might occur, followed by event B, followed by either event C or event D. Program flow might often include events A and B, with the choice between C and D determining the next sequence of events. The branching must be monitored, since the flow of the program depends on it.

Non-sequential word recognition is similar to sequential and nested word recognition except that the trigger can follow a software algorithm where the next event depends upon the result of a test. For example, a command parsing algorithm is non-sequential.

Event counters and delay timers increase the versatility of the logic analyzer trigger. An event counter counts the number of occurrences of an event. Using the event counter, you instruct the logic analyzer to trigger only after the nth occurrence of the event. A delay timer works similarly, except that the trigger is delayed a given length of time rather than waiting for the nth event.

Trigger arming allows a logic analyzer to acquire data based on two different clocks. One section of the analyzer monitors data lines at the system clock rate until a trigger event is found. It then arms another section of the analyzer running at a high asynchronous clock rate to allow it to trigger and acquire high speed timing information. The event which triggers it could be a trigger event detected independently or it could be a programmed delay from the arming signal, or a combination of both.

An example of arming is when you want to investigate high speed hardware phenomena such as control pulses to a microprocessor but you want to monitor address lines to determine when to investigate the control lines. When the analyzer section monitoring the address lines at slower speed finds the proper trigger event, it enables the other analyzer section running at higher speed to take a high-resolution look at the control lines. Note that the analyzer section monitoring the address lines must be clocked synchronously, while the other section is clocked asynchronously.

Display

If you think for a moment about how much data you can acquire with a logic analyzer, you will quickly realize that it is extremely important to manipulate and display the data carefully to be able to find the significant points quickly and reliably. Tektronix logic analyzers give you considerable flexibility, so that you can see the data you need the way you want to see it.

There are three basic types of output display: timing diagram, state table, and mnemonic disassembly. For the timing diagram the data stored in memory are used to construct a multi-trace waveform drawing which looks a lot like a multi-channel display on an oscilloscope. The timing diagram is usually the preferred method to observe data acquired asynchronously at high speeds. It helps the user locate hardware faults.

The state table allows the user to observe data describing the state of the circuit under test in tabular form. It is the preferred output for data acquired synchronously. The data is much more readable if it can be grouped into fields and displayed in octal or hexadecimal format, as well as in binary. Also the ability to group the data in fields relating to the circuit under test rather than to the logic analyzer probes makes it easier to understand what is really happening.

Mnemonic disassembly allows the user to observe the data in the state table in much more readable form. For example, it is much easier to understand the event flow of a microprocessor when the instruction codes are shown rather than the numerical machine code. That is also true for messages in a character code such as ASCII and for transactions on a bus such as the GPIB. Some mnemonic disassembly tables may be built into the hardware of the logic analyzer as you purchase it, but it is also helpful if you can define your own mnemonics.

Instrument Control

As you can appreciate from the descriptions above, the logic analyzer offers you great flexibility. To use this flexibility you must set up the instrument to acquire data in the manner you desire and you must be able to display it the way you want. To do all this with conventional knobs and switches would be very cumbersome. So Tektronix has provided the ability to deal with each logic analyzer in the optimum way for the application. Since the 7D01 is intended for hardware oriented people, it looks more like a hardware controlled box. The 7D02 programming is optimized to allow you to follow the program flow of a microprocessor. Through extensive use of menus the DAS 9100 allows you to specify a large number of parameters quickly and easily. The 308 is four instruments in one, compact in size, useful in both design and service.

An important aspect of control of logic analyzers is the interface to external controllers and peripherals. The user of instrumentation can save significant time as intelligent instruments talk to each other to speed up the testing process. Also, the ability to work with controllers allows the same instrument to be used in both design and manufacturing.

Pattern Generation

The traditional logic analyzer observes the circuit under test. Obviously, to observe the circuit and acquire meaningful data, something meaningful must be happening at the circuit. In the past the user has had to set up a separate stimulus instrument to drive the circuit in some known way in order to collect meaningful data. Often a lot of effort and time is expended in developing a suitable fixture. This is true especially during the early stages of design when the circuit to be tested cannot be tested in the environment of other known good circuitry.

The DAS 9100 is the first logic analyzer to have both stimulation and observation capability in the same instrument. It saves significant time for the designer, since he can set up a program to stimulate his circuit in the same way that he sets up the rest of the logic analyzer -- with prompted menus. Since the pattern generator allows algorithmic generation of data, a relatively short program can create a much larger sequence of data to drive the circuit under test. The pattern generator can be programmed to behave like the environment in which the circuit is to be used, so that the designer can test parts of a circuit design before all the prototypes are ready.

In addition, the tests created for the pattern generator can ultimately form the basis for evaluation and manufacturing tests. The pattern generator stimulates the circuit under test, the data is acquired in the acquisition memory and then compared to the contents of the reference memory to identify errors.

LOGIC ANALYZER SELECTION GUIDE

The guide which follows helps you to locate which Tektronix logic analyzers are best suited to your specific needs for applications and features. Since the guide is only a summary of the most salient points, you will find more information in the product descriptions which follow. Or call your Tektronix representative for assistance.

| APPLICATION/FEATURE | 308 | 7D02 | 9101 | 9102 | 9103 | 9104 | 9109 | 7D01 DF2 DL2 |
|---|--------|--------|---------|--------|---------|---------|---|--------------------|
| Bus Measurements: | | | | | | | | |
| Trigger on simple program execution | X | X | X | X | X | X | X | X |
| Trigger on complex program execution | | X | | X | X | X | X | |
| Measure execution time interval and state count | | X | | | | | | |
| Data qualification | | X | | | | | | |
| Stimulate bus transfers | | | | | | | | |
| Relate program execution to data | | X | | X | X | X | X | |
| Relate program execution to asynchronous control | | X | | X | X | X | X | |
| Analyze serial data transfers/communications interface | X | | | | | | | |
| Simultaneous state & timing | | X | | | X | X | X | |
| Time aligned state & timing | | | | | X | X | X | |
| Analyze asynchronous timing and glitches | X | X | X | | X | X | X | X |
| Microprocessor mnemonics | | X | | X | X | X | X | |
| User defined mnemonics | | | X | X | X | X | X | |
| Analyze GPIB transactions | | | X | X | X | X | X | X |
| Stimulation Capabilities: | | | | | | | | |
| Pattern compression | | | | X | X | X | X | |
| Synchronous clock output | | | | X | X | X | X | |
| Programmable strobe outputs | | | | X | X | X | X | |
| External control lines | | | | X | X | X | X | |
| Tri-state capability | | | | X | X | X | X | |
| Level swings selectable by pod | | | | X | X | X | X | |
| Service: | | | | | | | | |
| On-site | X | | | | | | | |
| Depot level | X | | X | X | X | X | X | |
| Remote control | | | | | | | X | |
| Hardware Debugging: | | | | | | | | |
| Glitch capture | | X | X | | X | X | X | X |
| Glitch triggering | | X | X | | X | X | X | |
| Synchronous acquisition speed | 20 MHz | 10 MHz | 100 MHz | 25 MHz | 100 MHz | 100 MHz | 25 MHz 100 MHz 330 MHz | 50 MHz |
| Asynchronous acquisition speed | 20 MHz | 50 MHz | 100 MHz | 25 MHz | 100 MHz | 100 MHz | 25 MHz 100 MHz 330 MHz 660 MHz | 100 MHz |
| 1.5 ns timing resolution | | | | | | | X | |
| Simultaneous state & timing acquisition with time alignment | | | | | X | X | X | |
| Test fixture elimination | | | | X | X | X | X | |
| System Capabilities: | | | | | | | | |
| Mass storage | | | | | | X | X | |
| Programmable via RS-232C | | | | | | | X | |
| Programmable via GPIB | | | | | | | X | |
| Display hard copy | | | X | X | X | X | X | |
| Trigger output | X | X | | X | X | X | X | X |
| Trigger input | X | X | | X | X | X | X | X |
| Modular and expandable | | | X | X | X | X | X | X |
| 7000 Series compatible | | X | | | | | | X |

NEW

DAS 9100 Data Analysis System

Up to 104 Acquisition Channels

Synchronous Acquisition to 330 MHz

Asynchronous Acquisition to 660 MHz

Up to 80 Channels of Pattern Generation to 25 MHz

An Architecture for Future Growth

Easy to Learn and Easy to Use

Affordable



The digital evolution, especially microprocessor technology, has touched every facet of electronic instrumentation. Bus structures have become wider, faster, and more complex. This has led to an increase in total hardware and software design complexity. These events created a need for a new state-of-the-art general purpose logic analyzer. The DAS 9100 is that logic analyzer. Its configurable capabilities allow for data acquisition, stimulation and remote control to provide optimum performance in a broad range of test situations.

For high speed data acquisitions, the DAS 9100 provides clock rates to 330 MHz synchronous and 660 MHz asynchronous. Also, data storage can be up to 4096 bits per channel to capture the data you want.

To accommodate wider, more complex bus applications, the DAS 9100 provides up to 104 channels of data acquisition. Also, glitch capture, split clocking, up to 7 clock qualifiers, and multiple levels of sequential triggering help you pinpoint problem areas in your system. For extra difficult problems, the trigger arms mode provides the capability to look at address/data bus transactions and asynchronous handshaking events simultaneously. And, the DAS 9100 goes one step further by displaying the data time aligned in both timing and state table displays.

If you're doing prototype debugging, the DAS 9100 lets you define your own mnemonic labels for monitoring data flow. With pattern generation you can stimulate the prototype with a known pattern up to 80 channels width plus programmable strobes, and truly analyze the results.

And, best of all it's easy to use. A straight forward menu-driven user interface let's you concentrate on solving your problem, not on learning how to operate the DAS 9100.

DAS 9100 — A New Concept in Logic Analysis

Modularity is the key to the DAS 9100. The mainframe accommodates plug-in card modules, chosen by you according to your specific needs. In all, you've got over 132 modular combinations with which to work.

Four data acquisition card modules combine to offer asynchronous acquisition speeds up to 660 MHz and synchronous acquisition speeds up to 330 MHz. Timing resolution down to an unprecedented 1.5 ns. And, data widths from 8 channels at 660 MHz, to 104 channels at 25 MHz.

TABLE I
DATA ACQUISITION MODULES

| Characteristics | 91A04 & 91AE04** | | | |
|-------------------------------|---|---------------|---------------------|---------------------------|
| | *91A32 | 91A08 | Full Channel Mode | High Resolution Mode |
| Number of Channels Per Module | 32 | 8 | 4 | 2 |
| Resolution/ Sample Freq | 40 ns/25 MHz | 10 ns/100 MHz | 3 ns/330 MHz | 1.5 ns/660 MHz |
| Modules Per System | 3 | 4 | 1 91A04 3 91AE04 | 1 91A04 3 91AE04 |
| Channels Per System | 96 | 32 | 16 | 8 |
| Memory Depth | 512 | 512 | 2048 | 4096 |
| Triggering | ***nA → B ≠ C 1 level plus arms mode | | | |
| Multiple Clocks | 3 With 91A32 | | | |
| Synchronous | YES | YES | YES | NO |
| Asynchronous | YES | | | |
| Glitch Triggering | NO | YES | 3 ns resolution | 1.5 nanosecond resolution |
| Qualifiers Per Board | 2 | 1 | 0 | |
| Set-up Times | 29 ns/0 ns | | | |
| Hold Times | 9 ns/0 ns | | | |
| Number of Probes | 4 | 1 | | |

*Data and clock thresholds selected independently.

**The 91A04 is a master card, channel expansion requires one or more 91AE04's.

***n occurrences of A followed by B, reset on C.

Table I summarizes the characteristics of Data Acquisition Modules.

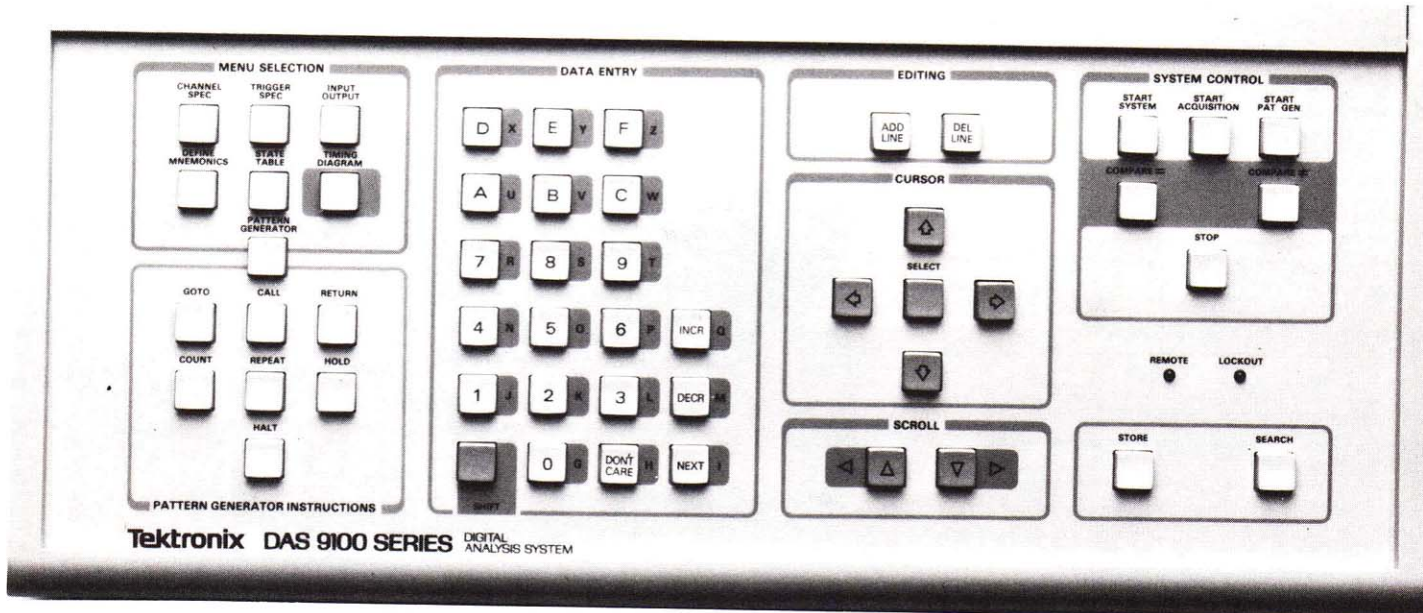

Figure 1. The layout of the DAS 9100 keyboard makes it easy to learn and easy to use.

DAS 9100 — Select YOUR Configuration

The DAS 9100 has four different data acquisition modules. Each has its own data width and maximum speed: 32 channels at 25 MHz; 8 channels at 100 MHz with glitch memory; 4 channels at 330 MHz or two channels at 660 MHz. Modules can be combined to give you the logic analyzer you need.

Need high speed performance? One module can track your system clock (synchronously) at speeds to 330 MHz or provide asynchronous sampling to 660 MHz. The eight channel module provides *both* synchronous and asynchronous sampling at 100 MHz. And the 32 channel module can be used to arm the trigger on those modules with higher acquisition rates.

To back it all up, there's powerful triggering, clock and trigger qualification, programmable reference memory and multiple clocks. There is glitch triggering, with a separate glitch memory for unambiguous glitch detection and our unique, new "arms mode" which allows precise timing correlation between synchronous and asynchronous data.

Arms mode allows the DAS 9100 to capture synchronous and asynchronous data simultaneously and the data are *displayed in the correct time relationship* for easy analysis in either Timing or State display mode. To obtain the data width and speed your application requires, simply select the appropriate combination of modules and add on later as your needs change.

For operator convenience, there is a mnemonics menu which permits definition of up to 256 separate mnemonics. These can be assigned to a particular group of data channels for display formatting (all 256) or spread over 16 different groups. The mnemonics display for each group can be turned on or off as desired. The assigned mnemonic can be up to 10 characters in length. A trailing words feature allows you to specify that mnemonic disassembly is to be skipped on a certain word or group of words, up to nine.

At last, you can have the tool that covers your digital system debugging needs. By combining pattern generation and data acquisition modules, you can stimulate your prototype while simultaneously analyzing its operation; allowing you to enter a whole new dimension of design analysis and verification.

Pattern generation makes it possible to start debugging hardware before your software, or even all of your hardware, is available.

Pattern generation capability is built around a 16 channel, 25 MHz controller module. Through additional expansion modules, you can increase the total up to 48 or 80 channels while maintaining full system speed. The pattern generator allows interaction with the prototype through clock outputs, data strobes, an external clock, and external control inputs, including an interrupt line. And, the pattern generated can even be changed, based on the data acquired by the logic analyzer, through the external control lines.

Table II summarizes capabilities of the two Pattern Generator Modules.

TABLE II. PATTERN GENERATOR SUMMARY

| Characteristics | Pattern Generator 91P16 (Controller) | Modules 91P32 |
|------------------------------|--------------------------------------|---------------------------|
| Modules Per System | 1 | 2 |
| Channels Per Module | 16 | 32 |
| Strobes Per Module | 2 | 4 |
| Clock Frequency | 25 MHz | 25 MHz |
| Number of Probes per Modules | 2 8 Channels/ Probe | 4 8 Channels/ Probe |
| Number of Program Steps | 254 | 254 |

Maximum Number of Channels is 80.

For you to make good use of an instrument, it needs to be easy to use. The logical grouping of the keyboard on the DAS 9100 simplifies the operator's task considerably (figure 1). The Menu Selection and Pattern Generator keys are used for setting up a specific task. The Data Entry keys are used to enter values. The operator uses the Editing, Cursor and Scroll keys to interact with the display. The System Control keys allow control of overall system operation.

The DAS 9100 also offers you powerful I/O options, including a built-in magnetic tape cartridge drive (option 01) to create files of instrument set ups, pattern sequences, mnemonics and reference memory. The Option 02 RS-232 and GPIB interface offers complete remote programmability. And, a hard copy interface is also included.

DAS 9100 — High-Speed Timing Analysis

The trigger specification menu (figure 1) lets you choose either synchronous or asynchronous timing acquisition. Normally, you will be using asynchronous sampling to see control signal operations (handshaking, interrupts, read/write) which do not occur synchronously with the same edge of the master clock. For tracing timing bugs, the DAS 9100 combines flexible triggering with glitch triggering to capture and display rapidly changing data.

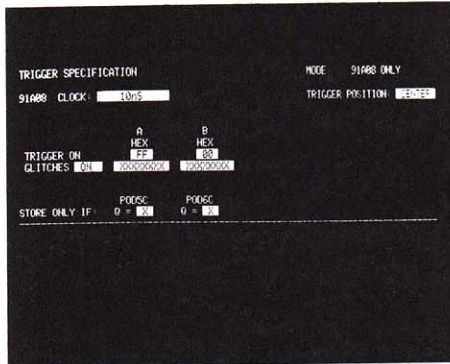

Figure 2. Trigger Specification menu

For high-speed timing, your mode would be 91A08 only or 91A04 only. This parameter sets up the DAS 9100 for acquiring data only with 91A08 or 91A04 modules. Parameters are selected via the trigger spec menu.

A typical example (figure 2) is for 100 MHz sampling on 16 channels of data using the two 91A08 modules plugged into mainframe slots 5 and 6. The glitch trigger is enabled and the sample rate is set to 10 ns using the internal clock. The trigger event is shown and the desired trigger position is centered to view data on both sides of the trigger event. The qualifiers, "store only if", are all set to X (don't care.) Also, the threshold is set for TTL on both modules. Hexadecimal radix is selected for state table viewing.

When the trigger event is recognized, acquisition is completed and the data recorded in memory is displayed.

In the timing diagram display (figure 3) the information can be easily analyzed. The channels are labeled for convenient identification and the trigger event is displayed at the top and highlighted in the display by the vertical line labeled **T**. The glitches display is ON and the glitches are presented. If there is any concern about differentiating glitch from data, simply turn the glitch field to OFF to remove glitches. Also, the cursor location (labeled **C**) is displayed at the top of the screen.

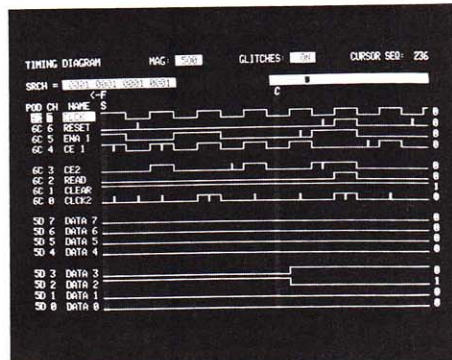

Figure 3. Timing diagram with glitches

The 91A08 module samples up to 100 MHz and uses glitch triggering to capture narrow pulses.

The 91A04/91AE04 module is a high-speed module that samples synchronously to 330 MHz and asynchronously to 660 MHz. By using the 91A04/91AE04 module, you can view "glitches" with 1.5 ns resolution and truly *analyze* where those errant pulses originated.

As a timing analyzer, the DAS 9100 is unsurpassed in performance. You can label all sixteen timing channels with signal names of your choice, thereby taking the guesswork out of data identification. Data resolution can be selected from 40 ns to an unprecedented 1.5 ns to help you isolate very high-speed digital transactions on synchronous and asynchronous data lines.

DAS 9100 — Bus Analysis

When the DAS 9100 is used to analyze a bus structure, the synchronous mode will normally be used. The 91A32 module with 32 channels and up to a 25 MHz sample rate, is ideal for bus analysis. If 91A08 or 91A04 modules, which are ideal for asynchronous acquisition, are added, the DAS 9100 will provide synchronous and asynchronous data acquisition simultaneously to uncover asynchronous faults while monitoring synchronous execution (Arms Mode). The data are then displayed in a time correlated format for easy analysis.

When looking at data/address bus transactions, it is convenient to be able to group channels to allow for display formatting of acquired data.

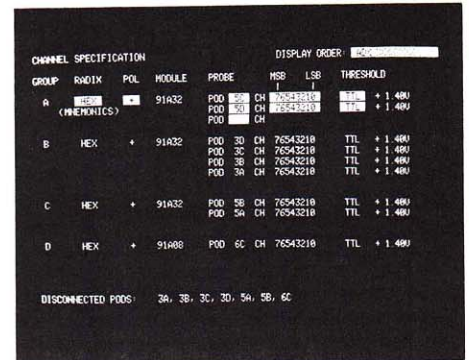

Figure 4. Channel Specification Menu

The Channel Specification Menu (figure 4) is used to group the probe channels into logical display groups in any order for convenient analysis. You can also select thresholds, logic polarity, radix, and the order in which the groups should be displayed.

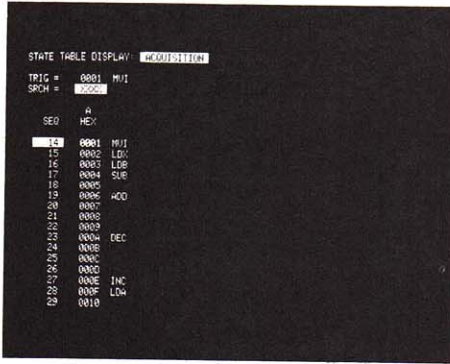

Figure 5. State Table Display

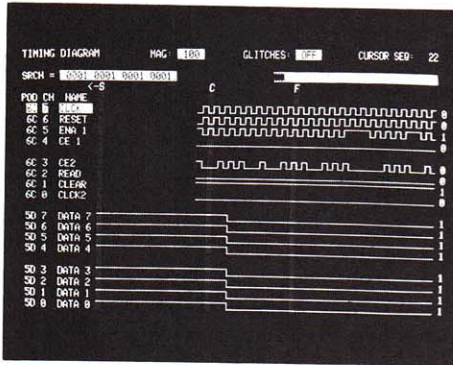

Figure 6. Timing Diagram of data acquired in arms mode

In the State Table (figure 5), as in the Timing diagram, the trigger word is displayed. The memory location or sequence numbers that correspond to the recorded events are also listed. To look at different sections of memory, either use the scroll keys or enter the sequence number you want.

The State Table lets you easily follow synchronous transactions which occurred on the bus around a specified event. With the arms mode, (figure 6) you can also observe control signal transactions to determine if their asynchronous activity is proceeding correctly.

Define Mnemonics

To make data easy to interpret, the DAS 9100 provides a Define Mnemonics Table (figure 7), which lets you define your own language of events by labeling data input words. The DAS 9100 can match each data word sampled to an assigned mnemonic and display them in the State Table. By assigning mnemonics to a set of events as you expect them to occur, a quick verification is achieved.

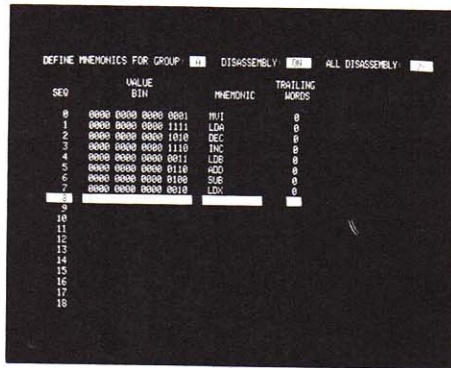

Figure 7. Define Mnemonics Table

Reference Memory

For intermittent problems, the reference memory provides the means for tracking down unwanted random transitions. By pressing the Store key, acquisition memory from the State Table is copied into reference memory (figure 8). Now, to track down an intermittent, press Compare ≠ and the DAS 9100 will begin acquiring data, based on the specified parameters, and compare it with known correct reference memory data. If the data is different, the DAS 9100 halts.

By selecting the Acquisition and Reference Memory, the intermittent will be shown as a highlighted difference and also a flag (≠) will be present beside the sequence number where the intermittent occurred.

To allow the DAS 9100 to help uncover specific intermittents within a small number of events, a programmable compare window is provided. With the data masking plus the compare window, comparison testing can be done on as little as a single bit.

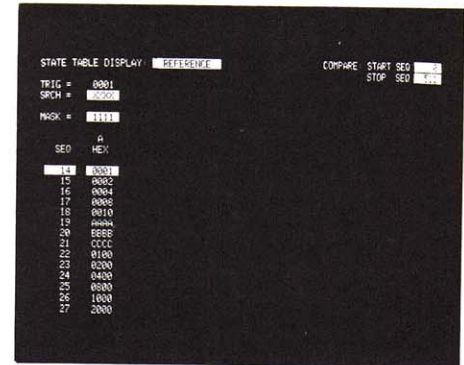
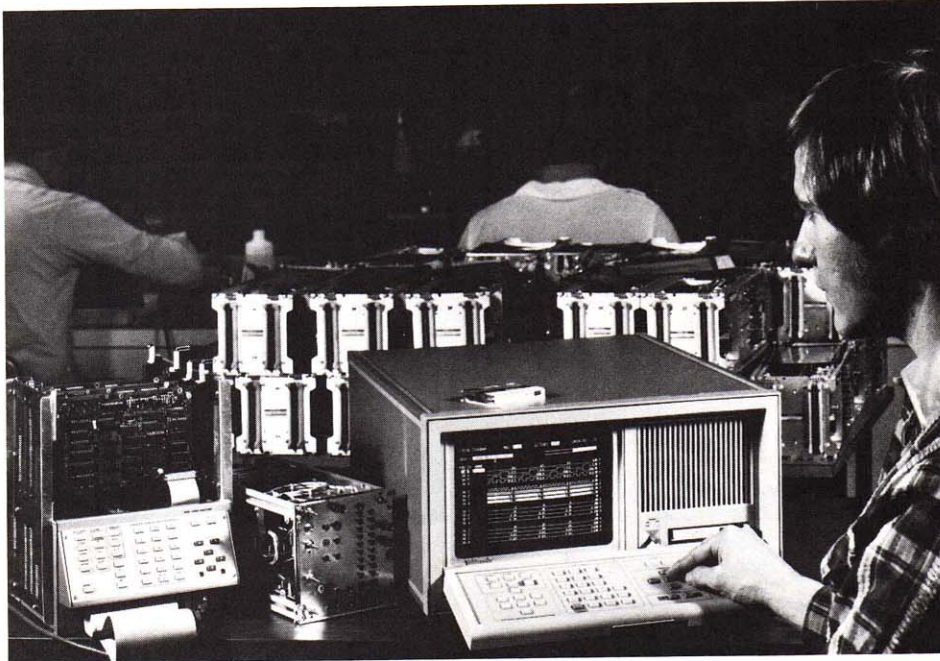

Figure 8. Reference Memory



With pattern generation and data acquisition in a single instrument, the DAS 9100 is useful in manufacturing test areas.

DAS 9100 — Pattern Generation

The DAS 9100 Pattern Generator provides up to 80 data signals and 10 programmable strobes at data rates up to 25 MHz. You can use these signals to stimulate your circuit either directly or with a minimal fixture of your own design. By stimulating the circuit from the pattern generator, you can start debugging parts of your circuit before all the other parts are ready. The ability to use a single logic analyzer to both stimulate and acquire data from a digital circuit is truly a new dimension in logic analysis.

The Pattern Generator is controlled by 7 powerful instructions (table III). Each of the instructions is a familiar word with a logical function performed by the DAS 9100.

TABLE III
PATTERN GENERATOR
INSTRUCTION SUMMARY

| INSTRUCTION | ACTION |
|-------------|--|
| COUNT | Increment Pattern by one clock cycle (256 max) |
| REPEAT | Repeat pattern output at this step up to 256 clock cycles |
| HOLD | Hold pattern and clock outputs at this step up to 256 clock cycles |
| HALT | Stop |
| GO TO | Go to designated Label |
| CALL | Jump to designated Subroutine Label |
| RETURN | Return from Subroutine |

The program menu allows a pattern to be entered as a sequentially executed program. Instruction steps may be labeled for either program looping or comments, and a strobe or group of strobes may be output at each instruction execution. With pattern depth of 254 vectors, coupled with looping and 16 levels of subroutine nesting, a complex digital circuit can be effectively stimulated without on-board firmware.

To connect the pattern generator output signals to your circuit, you use the P6455 Probe for TTL or MOS signals and the P6456 Probe for ECL signals. Thus data levels and strobes are programmable over a wide range of values to cover all logic families.

The clocking can be provided either internally from the time base module or externally via the External Clock probe.

To use the Generator Patterns, you may need to synthesize control signals to strobe the information into the circuit under test. The DAS Pattern Generator provides strobes that can be delayed in 40 ns increments from the system clock to provide gating signals.

The DAS 9100 Pattern Generator can also be controlled externally by the test circuit in any of three ways. Three external signals from the External Clock probe allow the pattern generator to be made to PAUSE, INHIBIT (tri-state) or INTERRUPT the program sequence and transfer execution to a subroutine pattern.

One of the best features of the DAS 9100 Pattern Generator is that it's easy to use. Since it is contained in your DAS 9100 Mainframe and you program it using the same menu approach as the rest of your DAS 9100 functions, you save time and money in getting your designs up and running. Moreover, you can easily save a complete stimulation acquisition test sequence for later use in evaluation, manufacturing, or service.

DAS 9100 — Storage and I/O

The DAS 9100 includes several optional storage and I/O capabilities. Using these features you can easily store and retrieve instrument set-ups and reference patterns, and control the instrument remotely.

Magnetic Tape Option



Figure 9.

The DC magnetic tape storage system, Option 01, (figure 9) can store a variety of status files from the DAS 9100, as shown in Table IV.

Table IV. MAGNETIC TAPE FILES

| File Type | Description |
|-----------|--|
| Patgen | Pattern Generator Menu and Memory |
| Define | Define Mnemonics Menu And Mnemonic Tables |
| Ref Mem | Reference Memory Contents |
| Data Acq | Channel Spec., Trigger Spec And Timing Diagram Menus |
| All | All of The Above |

The file directory (figure 10) allows 32 files per cartridge. Each tape can hold 6 ALL files with some space left for other files. Each file includes a header (figure 10) of up to 180 characters, which you can use for file description or usage instructions.

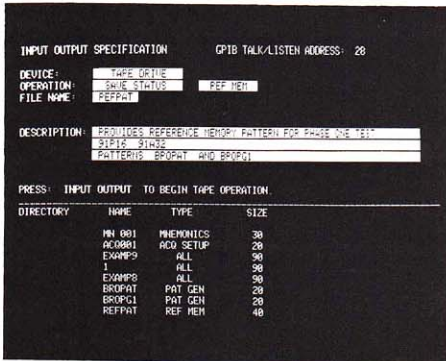

Figures 10. I/O Menu and File Directory

The DAS 9100 Option 02 includes a GPIB interface on RS-232C interface and a composite video output. These I/O ports provide a variety of useful possibilities for interfacing your DAS 9100.

GPIB

The GPIB port on the DAS 9100 is a standard IEEE-488 interface port and conforms to the IEEE-488 1978 standards and to the Tektronix *Codes and Formats* standard.

Using the English-like commands of the *Codes and Formats*, you can remotely control all of the capabilities of your DAS 9100.

Menus can be programmed, output patterns generated, data acquired and compared with reference patterns, and any results (acquisition memory for example) returned to the controller for further analysis.

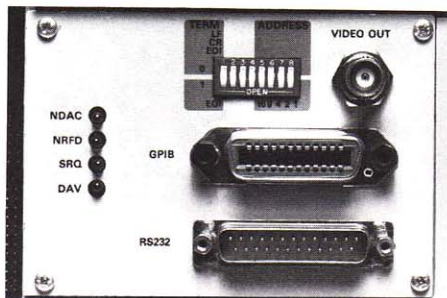

Figure 11. Rear I/O panel

The DAS 9100 operates via the GPIB port as either a talker or a listener, and is compatible with controllers such as the Tektronix 4041, 4051, 4052 or 4054.

The controller commands the DAS 9100 to perform all the functions which can be accessed from the DAS 9100 keyboard. LEARN mode allows the user to send individual keystroke sequences to the controller. This mode can be a real timesaver to modify previously stored DAS 9100 setup programs, when just a few changes are needed.

RS-232C

The first mode using the RS-232C port is essentially the same as the GPIB mode. The controller commands the DAS 9100 to perform the desired functions using the same commands as for GPIB. The RS-232C hardware interface works with standard modems.

Master-Slave

The second mode using the RS-232C port is Master-Slave operation. Using the DAS 9100 console (designated as Master), you can completely control a remote DAS 9100 (designated as Slave).

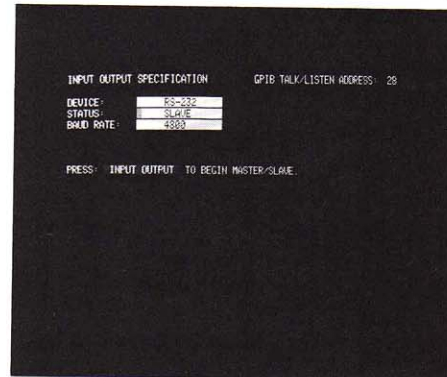

Figure 12. I/O Menu RS-232C SLAVE

Any keystroke command that is executed by the Master is transmitted to the Slave and implemented as if the remote user entered it on the Slave's keyboard. Screen contents on the Slave are transmitted automatically to the Master DAS 9100 screen.

For instance, you can use a MASTER in your engineering lab to control a SLAVE via telephone lines, thus saving travel and/or time to analyze a tough problem at a remote location.

Composite Video Output

The video out jack (figure 11) is part of Option 02 and provides a composite video signal to drive a video hardcopy unit or an external video monitor.

Recommended hardcopy units are TEKTRONIX 4612 and 4632 Video Copiers, which provide crisp, clear permanent copies of DAS 9100 screen contents.

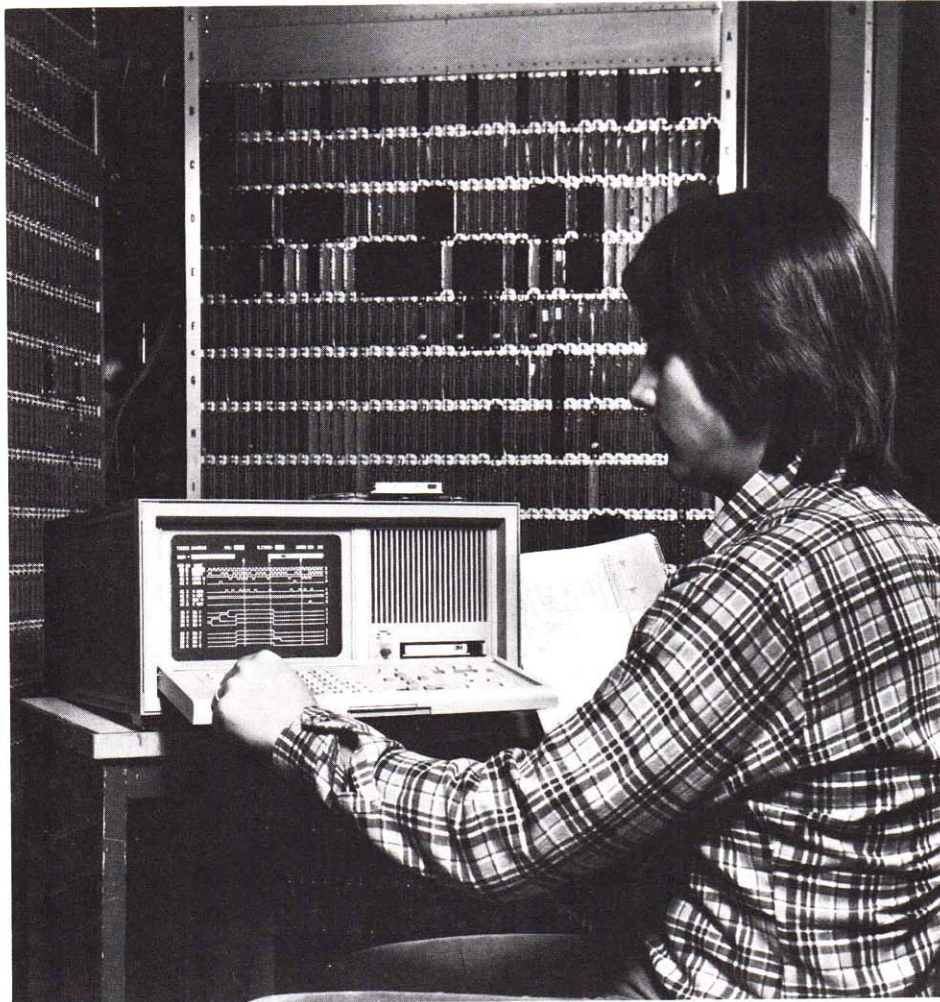

The ability to call up stored files for instrument set-up and the remote I/O capability allow the DAS 9100 to support a variety of service strategies.

DAS 9100

— The Logic Analysis System for You.

The DAS 9100 Digital Analysis System combines powerful data acquisition and pattern generation modules with an easy-to-use human interface to create a unique, state-of-the-art logic analysis system. You select the proper configuration for your present application today and select additional capability for future needs when the need occurs. The optional magnetic tape provides easy storage and recovery of instrument set-ups. And flexible I/O interfacing allows the DAS 9100 to be configured optimally in your environment.

CHARACTERISTICS

DATA FORMATTING

Group Designations — Up to 16 Groups (1 to 32 channels per group).

Display Order — Designate Group Display Order for State Table.

Channel Order — Designated channel order within a group.

Radix — Octal, Binary, or Hexadecimal.

Polarity — Positive or Negative (Complement).

Threshold — Select TTL or Variable.

USER DEFINABLE MNEMONICS

Up to 256 Mnemonic Definitions by Group

10-Character Mnemonic Field

TRIGGERING SPECIFICATIONS

Synchronous or Asynchronous

Trigger Word Position - Begin, Center, End of Memory

Trigger Delay from 1 to 32,767 Clock Samples

Displays Trigger Word in Hex, Binary or Octal, or mixed radix, any bits allowed as don't care (X)

Trigger Modes (Word Recognition) —

- 3 Word recognizers
- Word 1 (N)times
- Word 1 FOLLOWED BY word 2
- Word 1 THEN NOT word 2
- RESET on word 3
- External Trigger Enable (TTL)
- Word Recognizer Output (TTL)
- 91A32 arms 91A08 or 91A04/91AE04
- Compare until equal or not equal

Glitch Recognizer (91A08 only)

- Enable by channel
- OR ed with 91A08 trigger word

Clocks — Up to 4 split clocks (multiple 91A32 modules).

Clock Qualifiers — Up to 7.

DATA ACQUISITION DISPLAY MODES

Screen Size — 22.9 cm (9 in) diagonal, displays 24 lines of 80 characters.

Timing Diagram Features

- Simultaneous display of 16 user selectable channels
- User definable 6-character trace labels for each displayed channel
- Data magnification factors from X1 to X10,000
- Cursor position and word readout in binary
- Search word
- Time aligned data display for arming mode
- Glitch display select (91A08 only)
- Horizontal data scrolling
- Memory display window

State Table Features

- Hex, Binary, Octal, or mixed radix
- User definable mnemonics displayed by group in acquisition/reference memory displays
- Search word
- Time-aligned data display for arms mode
- Vertical or block scrolling
- Cursor position
- Up to 512 bits by 96 channels reference memory display, with or without data acquisition display
- Reference memory editing
- Programmable compare window
- Reference memory mask word capability
- Compare mode — highlighted and flagged for differences

KEYBOARD

The DAS 9100 keyboard is divided into four sections for ease of use and functionality. Menu keys, data entry keys, edit and cursor control, and system control keys provides total control at your fingertips.

DATA ACQUISITION PROBES

| CHARACTERISTIC | P6452 | P6453 | P6454 |
|--|---|----------------------------------|-------------------------------|
| Module used with | 91A32, 91A08 Trigger/Time Base | 91A04/91AE04 | 91A08 |
| INPUTS | 8 Data 1 Qualifier 1 GND or Reference | 4 Data 1 Clock 5 Reference | 1 Clock 1 Reference |
| Input Impedance without lead set | 1 MΩ ± 1% 5 pF (NOM) | 1 MΩ ± 5% 5 pF (NOM) | 1 MΩ ± 5% 5 pF (NOM) |
| Operating Input Range | -40 to threshold voltage +10 V not to exceed 40 V (dc + peak ac) | -2 V to +5 V (dc + peak ac) | -2.5 V to +5 V (dc + peak ac) |
| Threshold Range (Programmable) | -2.5 V to +5 V - TTL -10 V to +20 V - MOS | -2.5 V to +5 V | -2.5 V to +5 V |
| Threshold Accuracy (Ref to Programmed Threshold) | ± 100 mV ± 2% - TTL ± 160 mV ± 4% - MOS | ± 50 mV ± 3% | ± 50 mV ± 3% |
| Sensitivity (Centered on Threshold) | 500 mV p-p | 700 mV p-p | 700 mV p-p |
| Max Non-destructive | ± 40 V | ± 25 V | ± 25 V |

* Lead set adds ≈ 5 to 10 pF.

DATA ACQUISITION MODULES

91A32 DATA ACQUISITION MODULE

Maximum Number of Inputs — 32 data channels, expandable to 96 channels with 3 modules.

Maximum Sampling Rate — 25 MHz with internal or external clock (40 ns cycle time).

Memory Depth — 512 bits/channel.

Data Set-Up Time — (Period data valid prior to external clock edge) 29 ns, min.

Data Hold Time — 0 ns, min.

Clock Qualifiers — 2 per module, 6 max, selectable polarity.

Qualifier Set-Up Time — 29 ns, min.

Qualifier Hold Time — 0 ns, max.

Clock —

Internal — 5 ms to 40 ns ± 1% ± 1 ns.

External — Up to three external sources.

Selectable rising or falling edge.

Trigger — 1, 2 and 3 level word recognition arms 91A08 or 91A04.

Sequence Comparison — Compare until equal or not equal.

Probe — P6452, 4 per module. See table.

91A08 DATA ACQUISITION MODULE

Maximum Number of Inputs — 8 data channels expandable to 32 channels data with 4 modules.

Maximum Sampling Rate — 100 MHz with internal or external clock (10 ns cycle time).

Memory Depth — 512 bits/channel.

Glitch Storage — 5 ns min glitch width.

Data Set-up Time — ≤ 9 ns using one 91A08.

≤ 10 ns using multiple 91A08 Modules.

Data Hold Time — 0 ns, max.

Clock Qualifiers — 1 per module, 4 max.

Qualifier Set-up Time — ≤ 9 ns using one 91A08.

≤ 10 ns using multiple 91A08 modules.

Qualifier Hold Time — 0 ns, max.

Clock — Selectable from two internal and two external sources.

Internal — 5 ms to 10 ns, ± 1%, ± 1 ns.

External — Selectable rising or falling edge.

Trigger —

Word Recognition — Single-level data or glitch word, externally armable (from 91A32 trigger using arms mode).

Word Width — Up to 32 bits using four modules.

Sequence Comparison — Compare until equal or not equal.

Probes — P6452, 1 per module. See table.

P6454, 1 per DAS 9100; external clock for 1 to 4 91A08 modules).

91A04 AND 91AE04 DATA ACQUISITION MODULE

Maximum Number of Inputs — 4 data channels expandable to 16 channels with 4 modules; in high resolution mode 2 channels expandable to 8.

Maximum Sampling Rate — 330 MHz with internal or external clock. 660 MHz with internal clock.

Memory Depth — 2048 words; 4096 words in high resolution mode.

Data Set-up Time — 2.0 ns, min.

Data Hold Time — 0.0 ns, min.

Clock —

Internal — 3 ns to 5 ns, ± 5%; 10 ns to 5 ms. ± 1%.

External — Clock input channel from P6453 probe, 330 MHz, max.

Trigger — Word recognition or pattern sequence comparison
Word Recognition — Single-level data word, externally armable (from 91A32 trigger).

Delay — Selectable from 60 to 65541 sample periods after trigger.

Pattern-Sequence Comparison — Compare until equal or not equal.

Probe — P6453. See table.

91P16 AND 91P32 PATTERN GENERATOR MODULES

Up to 80 Programmable Data Output Channels.

Instruction Set —

Count(N) — Increment N values.

Goto — Label and output vector (pattern).

Hold(N) — Hold output and inhibit clock for N cycles.

Repeat(N) — Hold output while generating N clock cycles..

Call — Call subroutine.

Return — Return from subroutine.

Halt — Output vector and inhibit clock.

External Control Lines — From trigger-time/base probe.

Interrupt — Jump to subroutine.

Interrupt Input — External clock probe selectable rising or falling edge.

Interrupt Setup Time — 7 ns min relative to EXT Clock In. 72 ns min relative to clock output.

Interrupt Processing Delay — 4 clock cycles (Response Time).

Pause — Hold temporarily while asserted.

Pause Input — Selectable high or low true.

Pause Holdtime — 14 ns after pattern external clock transition.

Pause Pulse Width — 19 ns, min.

Inhibit — Tri-state all outputs while asserted.

Inhibit Input — Selectable high or low true.

Inhibit Delay Time — 70 ns max;

Pattern Data Width —

91P16 — 16 parallel channels (2 8-channel probes).

91P32 — 32 parallel channels (4 8-channel probes).

Expandable to 80 channels (1 91P16, 2 91P32's and 10 probes).

Operating Rate — 25 MHz max (40 ns cycle time).

Output Data Skew — ≤ 10 ns.

Pattern Memory Depth — 254 instructions or words (virtually unlimited pattern length).

Number of Nested Subroutines — 16 max.

Number of Labels — 32 max.

Number Of Strobes — 1 strobe per probe, expandable to 10 strobes (3 modules, 10 probes).

Strobe Start Time — Selectable from 70 ns to 40.91 μs in 40 ns steps.

Strobe Pulse Width — Selectable from 40 ns to 40.880 μs in 40 ns steps.

Strobe Pulse Polarity — Selectable: positive or negative.

Clock Output — One clock line per probe (rising edge signifies beginning of cycle).

Skew Between Different Probe Output Clocks — ± 5 ns.

Clock — Selectable external or internal.

Internal Clock — 40 ns to 5 ms ± 1% ± 1 ns.

External Clock — 40 ns min. Cycle time; selectable rising or falling edge.

Pause Input — Selectable high or low true.

Probes — See table.

P6455 TTL/MOS pattern generator probe.

P6456 ECL pattern generator probe.

PATTERN GENERATOR PROBES

| CHARACTERISTIC | P6455 | P6456 |
|---|---|---|
| Modules used with | 91P16, 91P32 | 91P16, 91P32 |
| Outputs | 8 Data 1 Clock 1 Strobe | 8 Data 1 Clock 1 Strobe |
| Inputs | V _H - high user supply rail voltage V _L - low user supply rail voltage | V _H - high user supply rail voltage V _L - low user supply rail voltage |
| Maximum user Supply levels | V _H - ± 20 V V _L - -20 V to +5 V V _{DIFF} - 25 V | V _H - ± 15 V V _L - ± 15 V V _{DIFF} - 10 V |
| Output drive current min source or sink | 3 V _{DIFF} to 5 V = 20 mA 5 V to 25 V = 10 mA | 50 Ω load to V _H - 2 V |
| Leakage (output inhibited) | < 100 μA | ECL output in low state |
| Capacitance | 10 pF nominal (lead set adds ≈ 10 pF) | 10 pF nominal (lead set adds ≈ 10 pF) |
| User current drain Maximum | 120 mA | V _H 130 mA V _L 130 mA V _{DIFF} = 5.2 V ± 5% |
| Output Logic Levels | V _{OH} > +1.6 V @ 20 mA V _{OL} < +0.5 V @ 10 mA; +0.6 @ 20 mA | V _{OH} - 6 V to -1 V V _{OL} - 1.65 to -2 V with 50 Ω load to V _H - 2 V |
| Logic Family | TTL - MOS | ECL only |

DC-100 TAPE DRIVE OPTION 01

Over 160k Bytes —
Stores 6 full configuration instrument set-ups
Stores 30 full acquisition set-ups
Stores 30 pattern generator files
Stores 30 define mnemonics files
Stores 15 reference memory files
Directory space for 32 files

I/O INTERFACE OPTION 02

RS-232

Selectable Baud Rates — 300, 600, 1200, 2400, 4800, 9600.

Inputs — Pin 3 Received Data.
Pin 5 Clear to Send
Pin 6 Data Set Ready
Pin 8 Data Carrier Detect

Outputs — Pin 2 Transmitted Data.
Pin 4 Request to Send
Pin 20 Data Terminal Ready

Other — Pin 1 Ground.
Pin 7 Signal Ground

Master/Slave —
Remote control of DAS 9100 by a DAS 9100.
Full duplex, asynchronous via RS-232.

GPIO

The Option 02 complies with IEEE Standard 488-1978 and with Tektronix Codes and Formats standard. (Talker and Listener only).

Capacitive Load Due to this Device — 100 pF per signal line max.

Lockout and Remote Lights Provided on Keyboard

Selectable Address
Selectable Controller Type

Four Rear-Panel LED's Provide Observable Handshake Lines — SRQ, NDAC, NRFD, DAV

COMPOSITE VIDEO OUTPUT

VON — 1.4 V to 1.6 V.
VOFF — 0.3 V to 0.7 V.
VSNC — 0 V to 0.1 V.
THSYNC — 63.5 μs ± 0.1 μs.
TVSYNC — 16.5 ms ± 0.1 ms.

MISCELLANEOUS

| Dimensions | cm | in |
|-----------------------|------|------|
| Height | 24.1 | 9.5 |
| Width | 43.2 | 17.0 |
| Length | 59.7 | 23.5 |
| Weight | kg | lb |
| (Without accessories) | 22 | 48.0 |

Power — 1,000 VA max.

Temperature Range —

Operating — 0°C to +50°C.

Storage — -40°C to +65°C.

Altitude —

Operating — 3000 m (10,000 ft) max.

Storage — 15,000 m (50,000 ft) max.

ORDERING INFORMATION
STANDARD CONFIGURATIONS

DAS 9101 Digital Analysis System \$11,700
(16 Channels at 100 MHz)

DAS 9102 Digital Analysis System \$12,900
(32 Channels at 25 MHz, 16 Channels of Pattern Generation)

DAS 9103 Digital Analysis System \$16,900
(32 Channels at 25 MHz, 8 Channels at 100 MHz, 16 Channels Pattern Generation)

DAS 9104 Digital Analysis System \$26,900
(64 Channels at 25 MHz, 16 Channels at 100 MHz, 16 Channels of Pattern Generation)

NOTES:

1 All Data Acquisition Modules, Pattern Generator Modules, and Mainframe Options are also available for the standard configurations with the exception of those already included in the configuration; i.e. DAS 9104 includes the Option 01, DC-100 Tape Drive.

2 If standard configurations are ordered with additional modules, check that the correct number of power supplies are included.

MAINFRAMES

DAS 9109 Mainframe \$4950

DAS 9119 Mainframe

(ATE Version) \$5400
(Deletes CRT and keyboard; adds Option 02)

OPTIONS

Option 01 DC-100 Tape Drive Add \$1250

Option 02 RS-232,

GPIO and Hardcopy Interface Add \$950

Option 03 Additional Power Supply Add \$750

Option 04 Two Additional Power Supplies Add \$1500
Option 05 Rackmount Hardware Add \$500
Option 88 Mainframe shipped with Modules installed and checked out as part of the Mainframe No Charge

INTERNATIONAL POWER CORD AND PLUG OPTIONS

Option A1 Universal Euro 220 V/16A No Charge

Option A2 UK 240 V/13A No Charge

Option A3 Australian 240 V/10A No Charge

Option A4 North American 240 V/15A No Charge

FIELD INSTALLABLE OPTIONS

DAS 91F1 Field Installed Option, DC-100 Tape Drive

(Includes installation in Service Center) \$1500

DAS 91F2 - Field Installed Option, GPIB Interface, RS-232

Hardcopy \$1100

MODULES

91A32 Data Acquisition Module \$4500

(32 Channels at 25 MHz, including Probes)

91A08 Data Acquisition Module \$3500

(8 Channels at 100 MHz, including Acquisition Probes, P6454 Clock Probe Required with First Module for Synchronous Operation)

91A04 Data Acquisition Module \$7950

(4 Channels at 330 MHz, including Probes)

91AE04 Data Acquisition Module \$4950

(4 Additional Channels at 330 MHz, including Probe. Requires 91A04)

91P16 Pattern Generator Module \$3700

(16 Channels at 25 MHz, including Probes)

91P32 Pattern Generator Module \$5900

(32 Channels at 25 MHz, including Probes. Requires 91P16)

NOTES:

1. When selecting modules, check that you do not exceed the following maximum numbers of modules or channels per instrument:

| TOTAL PER INSTRUMENT | QTY | SPECIAL REQUIREMENTS |
|-----------------------|-----|----------------------|
| Modules | 6 | |
| 91A32 | 3 | |
| 91A08 | 4 | |
| 91A04 | 1 | |
| 91AE04 | 3 | Requires 91A04 |
| 91P16 | 1 | |
| 91P32 | 2 | Requires 91P16 |
| Data Acquisition Ch's | 104 | |

2. When adding modules, check that the correct number of power supplies are also selected. The mainframe includes sufficient power for 2 modules. One additional power supply (Option 03) is required for 3 or 4 modules. Two (Option 04) additional power supplies are required for a total of 5 or 6 modules.

ADDITIONAL PROBES

P6452 8 Channels Data Acquisition Probe

(010-6452-01) \$700

P6453 4 Channels 330 MHz High Speed

Data Acquisition Probe (010-6453-01) \$1500

P6454 100 MHz Clock Probe (010-6454-01) \$250

P6455 8 Channels TTL/MOS Pattern Generator Probe

(010-6455-01) \$550

P6456 8 Channels ECL Pattern Generator Probe

(010-6456-01) \$550

ACCESSORIES

DC-100 Tape Cartridge (119-1350-01) (Pkg of 5) \$120

GPIB Cable , 2 Meter (012-0630-03) \$90

GPIB Cable, 4 Meter (012-0630-04) \$135

RS-232 Cable, 2 Meter (012-0815-00) \$55

Hardcopy Unit Cable : 75 Ohm, 42 in Coax, BNC

(012-0074-00) \$17

Hardcopy Unit Cable: 75 Ohm, 10 in Coax, BNC

(175-2753-00) \$13.50

Additional Power Supply (020-0707-00) \$750

DAS Set-Up and Hold Fixture (067-1037-00) \$1200

Carrying Case for Probes (016-0672-00) \$70

Rackmount Hardware (016-0463-00) \$500

308 Data Analyzer

The 308 is a 20 MHz, four-in-one portable Data Analyzer. It provides Parallel Timing, Parallel State, Serial State and Signature Analysis, in an easy to use convenient package.

With the color coded keyboard you can easily control all the functions of the 308 Data Analyzer.

The 308's unique menu readout displays all of the status and operator mode information on its self-contained CRT. The status information is always displayed as the first line in all modes of operation. This provides you with instant identification of what you're doing before, during and after data acquisitions.

The 308 Data Analyzer provides data acquisition via one 8 channel high impedance probe (1 M Ω , 5 pF) for parallel timing and parallel state modes. For serial and signature acquisitions a single channel high impedance probe (10 M Ω , 13 pF) is used. All four modes are provided with a selectable threshold, TTL or Variable (+ 12 to - 12 V), to allow data acquisitions from any digital logic family.

Input formats are selectable between Hexa-decimal, Binary, Octal or Decimal. For the Parallel State Mode direct display of acquisition memory is provided in Hex, Binary and Octal simultaneously.

In the Serial State Mode the display provides readout in Hex, Binary and ASCII simultaneously, plus parity error indication.

In the Parallel Timing mode a unique selectable Memory Window is provided to allow you to select the section of acquisition memory you wish to view. The window size is programmable for 42, 84, or 168 bits of display width.

A cursor mode is provided for Parallel Timing, Parallel State and Serial State that gives word position information with respect to the delayed trigger word. For Parallel Timing the cursor provides decoding of the timing diagram in any one of the four formats.

The 308 Data Analyzer comes with an 8 x 252 bit Reference Memory to provide compare and "Restart If" functions. The Reference Memory "Restart If" function can be used in both Parallel modes and the Serial State mode.

The 308 can have up to 16 bits of external word recognition with an optional probe. The 308 provides a Word Recognizer Trigger Out signal (TTL) to trigger other external equipment. An external qualifier input, selectable for trigger or clock, is provided; and when used in conjunction with the 8 channel data probe, plus the word recognizer probe, yields a total of 25 bits of word recognition for triggering.

The 308 Signature Analysis portion gives signatures in two different modes, Repeat and Hold. In the Repeat mode, a signature is taken and displayed; once displayed the 308 takes another signature. This process repeats until the stop key is pressed. In the hold mode the 308 allows the acquisition of signatures manually. By pushing the Hold Key the 308 will acquire and display up to eight signatures simultaneously on the screen.



CHARACTERISTICS

SIGNAL INPUTS

Parallel Timing & State — Multiline probe-tip, 8 data lines, 1 clock & 1 ground lead.

Maximum Number of Inputs — 8.

Input Impedance — 1 M Ω , 5 pF.

Logic Swing

Minimum — 500 mV + 2% of threshold voltage p-p centered on threshold voltage.

Maximum — ± 40 V or less, to at least threshold voltage.

Maximum Non-destructive Input Voltage — -40 V to +40 V.

Width of Data Input — Min 10 ns, with 400 mV overdrive from threshold voltage.

Threshold Voltage — Selectable.

TTL — +1.4 V to +0.2 V.

VAR — -12 V to +12 V.

Input Mode — Selectable.

Sample or Latch (to 5 ns with 500 mV overdrive voltage).

Serial State

Single channel probe input.

Input Impedance — 10 M Ω , 13 pF.

Non-destructive max input voltage 500 V peak at probe tip, 250 peak at BNC input connector.

Logic Swing

Minimum — 500 mV + 2% of threshold voltage, p-p centered about the threshold.

Maximum — ± 30 V peak.

Selectable Parity — ODD, EVEN or NONE.

Selectable Bits Per Character — 5, 6, 7 or 8 bits (includes parity if active).

Selectable Input Logic — Positive or negative (at probe tip).

Synchronizing Word (Synchronous mode only) — Programmable to require two equal words. If not programmed defaults to ASCII word SYN.

Hunt Word (Synchronous Mode only) — Programmable to require one word. If not programmed, defaults to "XXXXXXXX" (Not defined). One Hunt word is equal to 3 Hexadecimal "FF"s (Line idles).

Stop Bits (ASYNC ONLY) — Responds to one or more.

Signature Analyzer

Single channel data input via probe 10X — 10 M Ω ; 13 pF Clock start, and stop inputs provided by Data Acquisition probe. Slip-on tip to allow characterization of tri-state buss lines.

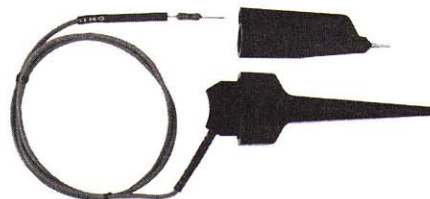

CLOCK

Parallel Timing & State

External Clock: Period — Min — 50 ns.

Pulse Width, Minimum:

High-Logic Level — 24.5 ns.

Low-Logic Level — 24.5 ns.

Data Setup Time, Minimum — 25 ns.

Data Hold Time, Minimum — 0 ns.

Internal Clock: 20 MHz.

Sample Interval, Minimum — 50 ns.

Data Pulse Width to Ensure Sampling,

Minimum — 1 sample interval + 10 ns.

Sample Intervals — 50 ns to 200 ns/sample in 1-2-5 sequence.

Qualifier Input

Selectable-Trigger or Clock

Input Threshold — TTL Level + 1.4 V ± 0.2 V.

Maximum Input Voltage — -5 V to +10 V peak.

Serial State

Synchronous or Asynchronous

Internal Clock for Asynchronous Mode Selectable Via Keyboard — 50, 75, 110, 134.5, 150, 200, 300, 600, 1200, 1800, 2400, 4800 and 9600 bits per second (baud rate).

Internal Clock Accuracy — ± 0.02%.

External Clock for Asynchronous Mode — Up to 9600 baud.

External Clock for Synchronous Mode — Up to 9600 baud.

MEMORY

8 x 252 bits Data Acquisition Memory.

8 x 252 bits Reference Memory.

TRIGGER

Parallel Timing & State

Synchronous or Asynchronous.

External Qualifier.

Data Word Recognizer — 8 Ch programmable in Hex, Binary, Octal or Decimal.

External Word Recognizer Probe — 16 Ch, programmable in Hex, Binary, Octal or Decimal.

Input Threshold — TTL (+1.4 V ± 0.2V).

Word Recognizer Trigger Out — TTL level (+1.4 V ± 0.20).

Trigger Delay — Programmable from 0-65535 delay by clocks.

Data Position — Selectable in Pre- or Post-Trigger Positions, First Trigger Mode (Internal Select).

Serial State

Data Word Recognizer — Programmable to require a sequence of two words (or characters).

External Trigger — Programmable for one bit 0, 1, or "X".

Trigger Delay — Programmable from 0 to 65535 delay by word count (character).

Data Position — Selectable for Pre- or Post-Triggering.

Framing Error Detection — When a valid stop bit is not detected, data acquisition is stopped.

DISPLAY

Status information of the 308 is always displayed at the top of the screen. Also, the menu of the 308 is displayed with all fields visible. In the Serial State the 308 provides an extended menu for additional Serial capabilities.

Timing Diagram

Programmable Window Memory Size.

Cursor Position Pointer and Word Decode.

Positive or Negative Display Logic.



Parallel State

Displays Hex, Binary & Octal simultaneously for quick decode.

12 Word Display Table.

Search Mode — Inverse video highlighting.

Compare Mode — Inverse video highlighting of differences Positive or Negative Display Logic.

Signature

Displays the edge selects for clock, start and stop. Also displays each signature taken simultaneously.

Displays a 4 digit signature.

Displays Characters — 0 - 9, A, C, F, H, P, U.

Serial State

Displays Hex, Binary, & ASCII simultaneously.

12 Word or Character Display.

Search Mode, Inverse Video Display of Word.

Compare Mode; Inverse Video Display of Differences.

Positive or Negative Display Logic.

PHYSICAL CHARACTERISTICS

| Dimensions | cm | in |
|----------------|------|-------|
| Heights | 11.7 | 4.61 |
| Width | 23.7 | 9.30 |
| Depth | 35.9 | 13.90 |
| Weight | kg | lb |
| Without Probes | 3.7 | 8.0 |
| With Probes | 4.5 | 10.0 |

Power — 90 V to 132 V ac, 180 V to 250 V ac, 48 Hz to 440 Hz.

Consumption — 40 W max.

Temperature Range — 0°C to 50°C, operating.

INCLUDED ACCESSORIES

Each 308 Data Analyzer comes with an accessory pouch, one 8 channel Data acquisition probe, with harmonica connector, plus sprung hook clips, a power cord and slip-on tip.

ORDERING INFORMATION

308 Data Analyzer \$3950
Includes P6451 Parallel Data Acquisition Probe and P6107 Serial Probe.

Option 01 P6406 Word Recognizer Probe Add \$420

1105 Battery Power Supply \$1240

1105 Power Supply provides 1.5 to 2 hrs. of nominal operation.

Option 01, 230 V Operation No Charge

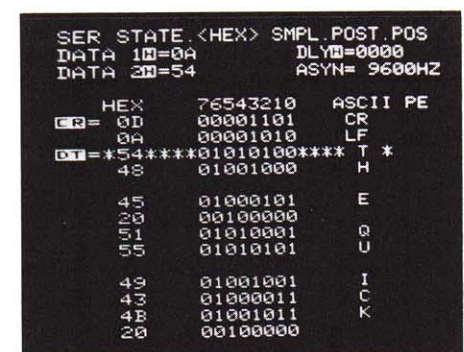
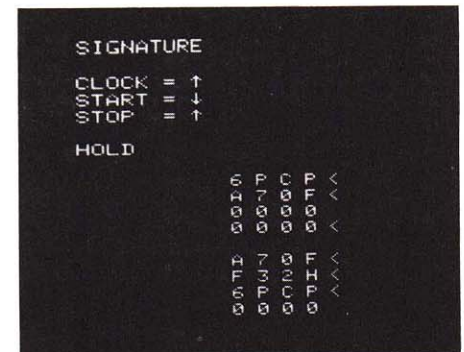
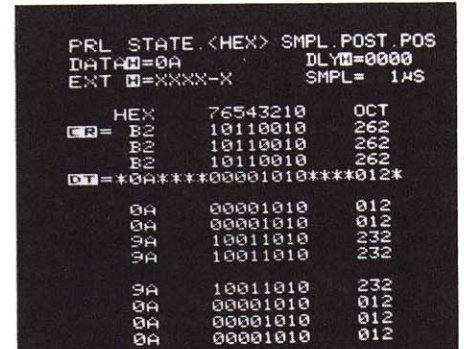

The SONY®/TEKTRONIX® 308 is manufactured and marketed in Japan by Sony/Tektronix Corporation, Tokyo Japan. Outside of Japan the 308 is available from Tektronix, Inc., its marketing subsidiaries and distributors.

7D02 Microprocessor Analyzer

Unprecedented Triggering Power in Both the State and Timing Modes of Data Acquisition

Disassembled Mnemonics for Fast, Simplified Interpretation of State Information

Up to 52 Data Channels

A Unique Configurable Menu to Enhance Testing Power

Synchronous (External Clock) and Asynchronous (Internal Time Base) Operation

Configurable to Individual 8 and 16 Bit Microprocessors

The 7D02 Logic Analyzer can acquire up to 52 channels of state information in the synchronous mode, using the clock of the system under test. The basic instrument contains 28 channels, with an expansion option (03) increasing this to 44. A timing option (01) provides 8 additional channels for a total of 52 synchronous channels. Alternatively, the Timing Option provides 8 channels of asynchronous information, using the 7D02's own clock. The state and timing sections can be operated independently, or used as a trigger source for one or the other.

All the 7D02's data acquisition resources are under the control of a unique user language, which allows them to be configured according to the needs presented by a particular situation. Through user programming, almost any combination of resources can be employed to construct specific triggers or data qualifiers.

Synchronous resources include four independent word recognizers up to 48 bits each, two universal time/event counters which can interact with each other and may be reset on the fly, and several modes of clock qualification. Asynchronous resources include a word recognizer, and an 8-channel glitch recognizer with an independent memory.

A series of Personality Modules can adapt the 7D02 to the specific characteristics of individual processors, both 8- and 16-bit. Once data is acquired, it can be displayed in the disassembled mnemonics of the processor in use, as well as hex, octal, ASCII and binary formats. Also available will be a general purpose Personality Module which will enable the user to support those microprocessors not specifically supported by the 7D02, or for other general purpose logic analysis tasks.

CHARACTERISTICS DISPLAY

Type — State Table; Raster scan — 24 lines x 32 characters per line. Number of Channels Displayed: (Basic 7D02) = 28, Data = 8, Address = 16, Control = 4. Max Number Acquisition: Memory Locations Displayed = 19.

Radices Available —

Data: Mnemonic disassembly for each supported microprocessor. ASCII, Hex, Binary, Octal.

Address: Hex, Binary, Octal, ASCII.

Control: Mnemonic Disassembly, Binary.



SIGNAL INPUTS

Signal inputs for the 7D02 are obtained through optional Personality Modules. These Personality Modules, along with Option 03 determine the number of channels that will be input to the 7D02.

Basic 7D02 — Data = 8, Address = 16, Control = 10, Ext Trigger = 1; Total = 35.

Input Impedance — Determined by the Personality Module (PM) used.

External Trigger — Input Impedance = 1.0M \pm 2% compatible with a 10X coded probe. Threshold = 1.4 V, Setup Time = 10 ns at BNC, Hold Time = 18 ns at BNC.

CLOCK

Synchronous Only — Maximum Raw Clock Input 20 MHz. Minimum time between qualified clocks = 100 ns. Setup/Hold Time — Determined by PM used. Qualifiers — Max Number = 6. 7D02 is capable of shifting or dividing qualified clocks by up to four positions or times respectively.

DATA QUALIFICATION

Complex Data Qualification allows the acquisition memory to be turned on and off at any time through use of Word Recognizers and Counters. This simulates large acquisition memory and pattern search capability.

MEMORY SIZE

Acquisition Memory (Basic 7D02) — 28 x 256.

Storage Memory (Basic 7D02) — 28 x 256.

COUNTERS

2 Universal Counters — Counting Mode: Time Mode; Resolution = 1 ms or 1 μ s. Accuracy = $(\pm 1 \text{ count}) \times (\text{number of start/stop cycles}) \pm 0.01\%$ of value. Maximum count = 65,534. Events Mode: Maximum count = 65,534. Control Mode: Time Mode; Resolution = 1 ms or 1 μ s. Minimum interval generated = 2. Maximum interval generated = 65,534. Accuracy of generated interval = $(-0/+1 \text{ count}) \times (\text{number of start/stop cycles}) \pm 0.01\%$ of value $+(-0.2 \mu\text{s})$ Events Mode: Minimum interval generated = 2. Maximum interval generated = 65,534.

WORD RECOGNIZERS

Number of Word Recognizers = 4. Number of Channels (Basic 7D02) = 32, Data = 8, Address = 16, Control = 6, Ext. Trigger = 1, Timing Option Link = 1 (if timing option installed).

TRIGGERING

The 7D02 can be triggered from any of the Word Recognizers or from either of the Counters, in the Control mode. This gives the 7D02 the ability to track and trigger on very complex program flows.

TRIGGER POSITION

Number of qualified clocks displayed after the trigger point: Trigger Before Data = 240, Trigger Centered = 128, Trigger After Data = 16, Zero Delay = 0.

PROCESSOR HALT

The Processor can be halted when the 7D02 stops acquisition. Processor Halt Delay = (2 qualified state clocks after the 7D02 stops acquisition) + PM Delay Time.

TRIGGER OUT

TTL compatible, capable of driving a 50 Ω unterminated transmission line. Accuracy = 1 qualified clock + 86 ns \pm 35 ns after event occurs at Probe Tip.

MISCELLANEOUS

Size — Three wide 7000 Series Plug-in.

Weight — 3.6 kg (8 lb).

Power — Line Voltage Ranges — Determined by the 7000 Series Mainframe. Power Consumption Max — 49 W at nominal line voltage, includes all options.

Temperature Range — Operating = 0°C to 50°C. Nonoperating = -55°C to +75°C.

Altitude — Operating = 15,000 ft. Nonoperating = 50,000 ft.

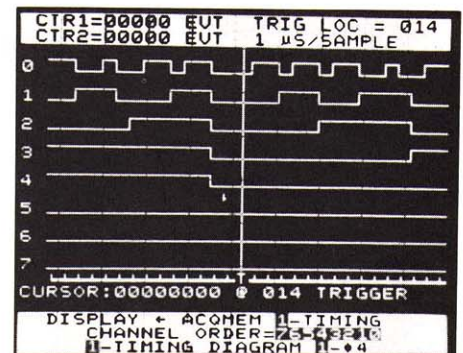

OPTION 01 — TIMING OPTION

The Timing Option provides the 7D02 user with 8 additional channels of asynchronous data acquisition at sample rates of up to 50 MHz.

SIGNAL INPUTS

Number of Channels — 8 (using a P6451 Data Probe). Input Impedance = 1 MΩ shunted by ≈ 5 pF.

Logic Swing — Min = 500 mV + 2% of threshold voltage centered on threshold voltage. Maximum = -15 V to at least threshold voltage + 10 V. Max Non-Destruct Input Voltage = -40 V to at least +40 V.

Threshold Voltage — Programmable from -6.35 to +6.35 in 50 mV increments.

Data Setup/Hold Time — Data Setup = 20 ns. Data Hold = 2 ns.

CLOCK

Asynchronous — Sample Rates = 20 ns to 5 ms in a 1-2-5 sequence. Accuracy = ± 0.01%.

Synchronous — Max raw input clock frequency 20 MHz. Obtained from system under test via the Personality Module. (Min time between qualified clocks = 100 ns.)

MEMORY SIZE

Acquisition Memory — 8 x 255. **Glitch Memory** — 8 x 255.

WORD RECOGNIZERS

One Data Word Recognizer — 8 channels (ANDed together).

One Glitch Word Recognizer — 8 channels (ORed together but ANDed with the Data Word Recognizer).

Ext Trigger In.

TRIGGERING

The Timing Option can be triggered from any or all of the following sources: 1. Timing Option Data Word Recognizer; 2. Timing Option Glitch Word Recognizer; 3. Main Section (7D02) Word Recognizers; 4. External Trigger In.

DIGITAL DELAY

Maximum Delay — 65,534 Sample Clocks.

GLITCH LATCH

Min. Pulse Width — 5 ns. ASYNCHRONOUS Mode Only.

DISPLAY

Timing Diagram Mode — Number of Channels = 8, Window Size = 124 words in X1 mode or 31 words in X4 mode. Data channels can be relocated by the user. Numeric Formats: Hex, Octal, Binary, ASCII. Glitches displayed as a * in the table beside DATA. Timing Display: Glitches are displayed by an i above the line where the glitch occurred. Max Number of Words Displayed = 19. Numeric Formats: Hex, Binary, Octal ASCII. Number of Words Scrolled = 255. Trigger Position Accuracy = ± 1-bit (ASYNCHRONOUS Mode).

MISCELLANEOUS

The P6451 Data Acquisition Probe comes standard with an Option 01.

OPTION 03 — EXPANSION OPTION

The Expansion Option provides the 7D02 with the ability to support most 16-bit microprocessors.

SIGNAL INPUTS

Adds an additional 16 bits to the 7D02. Data = 8; Address = 8.

WORD RECOGNITION

Maximum Number of Channels — 48. **Data** — 16. **Address** — 24. **Control** — 6. **Ext. Trigger** — 1. **Timing Option** — 1 (if timing option installed).

DISPLAY

Maximum Number of Channels — 44. **Data** — 16. **Address** — 24. **Control** — 4.

MEMORY SIZE

Acquisition Memory — 44 x 256. **Storage Memory** — 44 x 256.

ORDERING INFORMATION

- 7D02 Logic Analyzer \$4400
- Option 01 (timing) Add \$1700
- Option 7D02F01 (timing, field-installed) \$2050
- Option 03 (expansion) Add \$1200
- Option 7D02F03 (expansion, field-installed) \$1400

OPTIONAL ACCESSORIES

- 016-0669-00 — (fits any 7600 or 7400 mainframe) Hardware kit, Electrical equipment: Logic Analyzer securing \$10
- 067-0939-00 — Service Maintenance Kit \$450

The 7D02 has a configurable menu. This example, useful for Debugging Real-Time μP Programs, will trigger if Address F820 is NOT FOUND within 100 ms of the occurrence of Address B000.

All test parameters supplied by prompts.

IF clause defines a data stream event, which may be either single or compound.

The 7D02 may simultaneously monitor up to 4 Word Recognizers and 2 Counters.

THEN clause defines a response to the event. In this case, setting counter #1 to zero and then incrementing every millisecond.

At the same time the counter is set, branch to the second test (bracketing allows simultaneous actions).

Sequential Activities are monitored using multiple "tests".

The 7D02 now monitors the data stream for an event to satisfy the second test's IF clause.

If the event occurs, then branch back to test #1 and start the program over. Concurrent measurements are in the same test.

Or if counter #1 has reached 100 ms, then activate the trigger.

By using the proper personality module, software flow can be displayed using the mnemonics of the chip under test. Here the Motorola MC6802.

```

TEST 1
IF
1 WORD RECOGNIZER # 1
1 DATA=XX
1 ADDRESS=F000
1 /NMI=X /IRO=X FETCH=X R/W=X
1 BA=X INVAL OP=X EXT TRIG IN=X
1 TIMING WR=X
1 THEN DO
1
1 COUNTER # 1 =MS
1 GOTO 2-RESET AND RUN
1
END TEST 1
TEST 2
IF
1 WORD RECOGNIZER # 2
1 DATA=XX
1 ADDRESS=F820
1 /NMI=X /IRO=X FETCH=X R/W=X
1

```

```

END TEST 1
TEST 2
IF
1 WORD RECOGNIZER # 2
1 DATA=XX
1 ADDRESS=F820
1 /NMI=X /IRO=X FETCH=X R/W=X
1 BA=X INVAL OP=X EXT TRIG IN=X
1 TIMING WR=X
1 THEN DO
1 GOTO 1
OR IF
1 COUNTER # 1 = 00100 MS
1 THEN DO
1 TRIGGER 0-MAIN
1 0-BEFORE DATA
1 0-SYSTEM UNDER TEST CONT.
1 0-STANDARD CLOCK QUAL.
END TEST 2

```

| LOC | ADDRESS | OPERATION | IRQ/NMI |
|------|---------|------------|---------|
| Q10 | F8034 | BNE \$F82C | 11 |
| Q11 | F8035 | F6 READ | 11 |
| Q12 | F8020 | INC \$0006 | 11 |
| Q13 | F802D | Q0 READ | 11 |
| Q14 | F802E | Q6 READ | 11 |
| Q15T | Q0006 | Q2 READ | 11 |
| Q16 | Q0006 | Q3 WRITE | 11 |
| Q17 | F8027 | BEQ \$F865 | 11 |
| Q18 | F8020 | Q4 READ | 11 |
| Q19 | F8031 | TST \$0004 | 11 |
| Q20 | F8030 | Q0 READ | 11 |
| Q21 | F8030 | Q4 READ | 11 |
| Q22 | F8034 | Q7 READ | 11 |
| Q23 | F8034 | BNE \$F82C | 11 |
| Q24 | F8035 | F6 READ | 11 |
| Q25 | F8020 | INC \$0006 | 11 |
| Q26 | F802D | Q0 READ | 11 |

7D02 MICROPROCESSOR SUPPORT

Tektronix will support all popular Microprocessors with the 7D02 Logic Analyzer. The following support is now available:

| Microprocessor Type | *7D02 Support Features | 7D02 Personality Module Required |
|---------------------|------------------------|--|
| 8-BIT | | |
| 8080 | FM | PM101 OPT 01 |
| 8085 | FM, P-C | PM104 |
| Z80 | FM, P-C | PM105 |
| 6800 | FM, P-C | PM102 |
| 6802/6808 | FM, P-C | PM103 |
| 6809/6809E | FM, P-C | PM111 |
| 6502 | FM | PM101 OPT 02 |
| 1802 | STD | PM101 and 062-6001-00 (Application Manual) |
| 8031 | STD | PM101 and 062-6003-00 (Application Manual) |
| 8039/8035 | STD | PM101 and 062-5999-00 (Application Manual) |
| 8048/8049 | STD | PM101 and 062-5999-00 (Application Manual) |
| 8051 | STD | PM101 and 062-6003-00 (Application Manual) |
| 8748 | STD | PM101 and 062-5999-00 (Application Manual) |
| 8751 | STD | PM101 and 062-6003-00 (Application Manual) |
| 6801/6803 | STD | PM101 and 062-6000-00 (Application Manual) |
| 16 BIT | | |
| 8086 | FM, P-C | PM106 |
| 8088 | FM, P-C | PM107 |
| Z8001 | FM, P-C | PM110 |
| Z8002 | FM, P-C | PM108 |
| 68000 | FM, P-C | PM109 |
| 9900 TMS/SBP | STD | PM101 and 062-6002-00 (Application Manual) |

*FM — Full Mnemonic Disassembly P-C — Pre-Configured, Single Plug, Interconnection STD — Standard Radices (Hex, Binary, Octal)

For those 8-Bit and 16-Bit microprocessors not currently supported by specific personality modules, and for general purpose applications, the PM101 General Purpose Personality Module is available. See Data Sheet AX-4489 for details.

PM100 Series Microprocessor Personality Modules

The PM100 Personality Modules are high performance data acquisition modules designed for use with specific microprocessors.

PM102 through PM111 interface with the system under test through a single plug for error free connection. The PM101 provides general purpose logic analysis capability through individual acquisition leads. The interface to the logic analyzer is also a single plug for easy change of processor type.

The modules, operating synchronously with the system under test, demultiplex busses, synthesize signals necessary to track processor status, and transfer data to the logic analyzer memory. Word recognizer displays are formatted in the mnemonics of the processor control signals. A synthesized control function allows triggering or data qualification on instruction fetches. The Personality Module also provides full mnemonic disassembly and formatting for the display.

The processor may be halted by the personality module when the 7D02 triggers.

PM101 General Purpose Personality Module

Data Acquisition and Display Formatting for any Type of 8- or 16-bit Microprocessor

The PM101 Personality Module offers data acquisition capabilities designed to fit any type of synchronous digital system including those with 8- or 16-bit microprocessors.

SYSTEM CHARACTERISTICS SETUP/HOLD TIMES

Clock/Qualifier Inputs —
Setup — 55 ns max. 35 ns typical.
Hold — 0 ns max.

Address and Data Inputs —
Setup — 45 ns max. 25 ns nominal.
Hold — 0 ns max.

ORDERING INFORMATION

| | |
|---|---------------|
| PM101 General Purpose Personality Module | \$1400 |
| PM101 Option 01 8080 Mnemonics | Add \$300 |
| PM101 Option 02 6502 Mnemonics | Add \$300 |

MICROPROCESSOR PERSONALITY MODULE

| | PM101 |
|--|--|
| Processors Supported | General Purpose Logic Analysis Including 8 & 16 Bit μP Option 01 8080 mnemonics Option 02 6502 mnemonics |
| REQUIRES 7D02 Option 03 | 44 Stored Channels w/Option 03 28 without |
| SIGNAL INPUTS Address Data Control | w/Option 03 24 16 10 |
| Impedance (nominal) | 1/2 LSTTL 25 pF |
| V _{in} low min/max | 0 V/0.5 V |
| V _{in} high min/max | 2.4 V/7 V |
| Maximum Input Non-destructive | -7 V to +15 V |
| Threshold Voltage Hysteresis (nominal) | 1.4 V 0.4 V |
| DISPLAYED CHANNELS Address Data Control | w/Option 03 24 16 4 |
| CLOCK Max Input Frequency | 20 MHz (100 ns MIN between Qualified Clocks) |
| Minimum Pulse Width-High/Low | 25 ns/25 ns |
| Input Impedance (nominal) | 50 k Ω 15 pF |
| PROCESSOR HALT DELAY 2 Qualified Clock Cycles Plus | 58 ns |

* Except Min/Max, HOLD, Reset, 2.0 to 5.5 V.
** Except min/max, Hold, Reset, -1 to +5.5 V.
*** Requires user modification to enable.

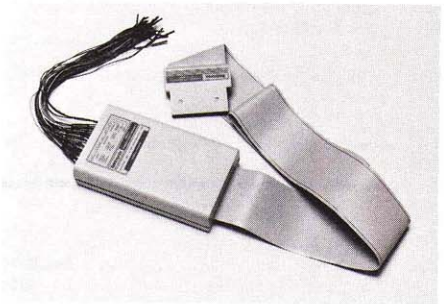

PM101 General Purpose Personality Module

PERSONALITY MODULE SPECIFICATION SUMMARY

| PM102 | PM103 | PM104 | PM105 | PM106 | PM107 | PM108 | PM109 | PM110 | PM111 |
|----------------------------------|----------------------------------|---|--|---|-------------------------------|---|---|--------------------------|---|
| 6800 68A00 68B00 | 6802 68A02 6808 | 8085 8085A 8085A-2 | Z-80 Z-80A Z-80B | 8086 8086-2 8086-4 | 8088 | Z8002 | 68000L4 68000L6 68000L8 68000L10 | Z8001 Z8001A | 6809,68A09 68B09,6809E, 68A09E,68B09E |
| NO | NO | NO | NO | YES | YES | YES | YES | YES | NO |
| 16 8 9 | 16 8 9 | 16 8 10 | 16 8 10 | 20 16 15 | 20 8 15 | 16 16 15 | 24 16 10 | 16 16 17 | 8 16 9 |
| 1/2 LSTTL 40 pF | 1/2 LSTTL 40 pF | 1/2 LSTTL 40 pF | 1/2 LSTTL 40 pF | 1/2 LSTTL 40 pF | 1/2 LSTTL 40 pF | 1/2 LSTTL 37 pF | 1 LSTTL 70 pF | 1/2 LSTTL 40 pF | 1/2 LSTTL 40 pF Except PHALT 1-LSTTL |
| 0 V/0.6 V 2.0 V/7.0 V | 0 V/0.6 V 2.0 V/7.0 V | 0 V/0.6 V 2.0 V/7.0 V | 0 V/0.6 V 2.0 V/7.0 V | -0.5 V/+0.5 V 2.0 V/7.0 V* | -0.5 V/+0.5 V 2.0 V/7.0 V* | 0 V/0.5 V 2.4 V/7.0 V | -0.5 V/+0.5 V 2.0 V/5.5 V | 0 V/0.5 V 2.0 V/7.0 V | 0 V/0.6 V 2.0 V/7.0 V |
| ±15 V | ±15 V | -7 V to +15 V | -7 V to +15 V | -5 V to +7 V** | -5 V to +7 V** | -7 V to +15 V | -7 V to +15 V | ±7 V | -7 to +15 V |
| 1.4 V 0.4 V | 1.4 V 0.4 V | 1.4 V 0.4 V | 1.4 V 0.4 V | 1.4 V 0.4 V | 1.4 V 0.4 V | 1.4 V 0.4 V | 1.4 V 0 V | 1.4 V 0.4 V | 1.4 V 0.4 V |
| 16 8 R/W,NMI,IRQ, FETCH | 16 8 R/W,NMI,IRQ, FETCH | 16 8 R/W,I/O MEM, INRQ (any interrupt) IFC (FETCH) | 16 8 R/W,(INTER REQ), I/O MEM, FETCH | 20 16 8 (see text) | 20 8 8 (see text) | 16 16 R/W,I/O MEM, INTREQ,IFC (FETCH) | 24 16 4 (see text) | 16 16 (see text) | 16 8 R/W,/IFC, (/IFC+IFC2), INT |
| 2 MHz | 6 MHz | 10 MHz | 6 MHz | 8 MHz | 5 MHz | 4 MHz | 10 MHz | 6 MHz | 8 MHz |
| 180 ns/180 ns | 180 ns/180 ns | 70 ns/40 ns | 70 ns/70 ns | 1/3 Clock Period +2ns/ 2/3 Clock period -15 ns | | 105 ns/105 ns | 44 ns/44 ns | 70 ns/70 ns | 220 ns/210 ns |
| 50 kΩ 35 pF | 50 kΩ 35 pF | 50 kΩ 40 pF | 50 kΩ 40 pF | 50 kΩ 40 pF | 50 kΩ 40 pF | 50 kΩ 37 pF | 50 kΩ 55 pF max | 50 kΩ 40 pF | 50 kΩ 35 pF |
| 90 ns | 90 ns | 63 ns | 60 ns | 80 ns*** | 80 ns*** | 65 ns | 50 ns | 73 ns | 50 ns |

For complete information and data sheets on microprocessor analysis products described, contact your nearest Tektronix Sales Office.

PM102 6800 Personality Modules

PM103 6802 Personality Modules

SYSTEM CHARACTERISTICS

SETUP AND HOLD TIMES

Data Inputs —

Setup — 40 ns max.

Hold — 0 ns max.

ORDERING INFORMATION

| | |
|-------------|--------|
| PM102 | \$1400 |
| PM103 | \$1400 |

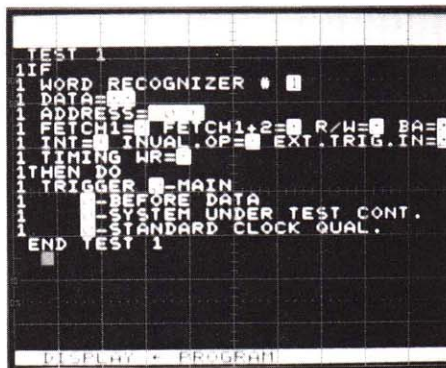

PM 103 Default Trigger Menu



PM103 Mnemonic Display

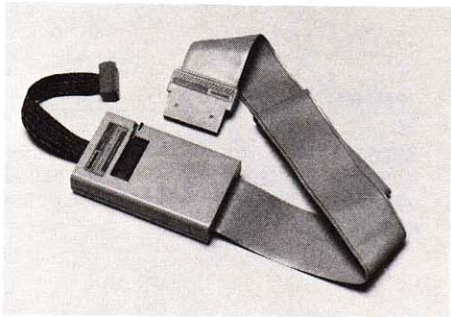

PM104 8085 Personality Module

SYSTEM CHARACTERISTICS

SETUP/HOLD TIMES

Data and Address Inputs —

Setup — 50 ns max.

Hold — 0 ns max.

ALE Input —

Setup — 40 ns max.

Hold — 0 ns max.

HOLD Input —

Setup — 120 ns (measured to trailing edge of CLK, t₂, or TWAIT).

Hold — 0 ns.

READY Input —

Setup — 135 ns max (referenced to rising edge of T₂).

Hold — 0 ns.

Order PM104 \$1400

PM105 Z-80 Personality Module

SYSTEM CHARACTERISTICS

SETUP AND HOLD TIMES (MAX)

| Parameter | Setup | Hold | Units |
|--------------|-----------------|-----------------|-------|
| Address 0-15 | 50 | 5 | ns |
| Data 0-7 | 35 ^a | 10 ^a | ns |
| M1 | 39 | 18 | ns |
| MREQ | 22 ^b | 0 ^b | ns |
| IORQ | 22 ^b | 0 ^b | ns |
| WR | 90 ^a | 5 ^a | ns |
| BUSAK | 46 | 4 | ns |
| HALT | 46 | 4 | ns |
| INT | 35 ^c | 4 ^c | ns |
| NMI | 74 | 0 | ns |
| WAIT | 50 ^d | 0 ^d | ns |

^aRelative to rising edge of clock on T3 for M1 cycle or to the trailing edge of T3 for memory or I/O cycles.

^bRelative to rising edge of clock on T1 for MREQ and to rising edge of clock on TW for IORQ.

^cRelative to rising edge of the clock of the last T state prior to an M1 cycle.

^dRelative to trailing edge of the clock of T2 state for a memory cycle or to TW for an I/O cycle.

Order PM105 \$1400

PM106 8086 Personality Module

PM107 8088 Personality Module

When used with the TEKTRONIX 7D02 Logic Analyzer, the PM106/PM107 solves the major problem encountered when debugging an 8086/8088 based design; that is understanding what is happening in the instruction queue. The logic analyzer acquires all the information transmitted across the data bus. Queue status is decoded to determine which instructions were actually executed and which were fetched but not executed.

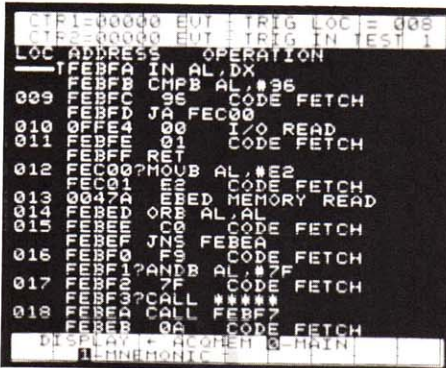

This 8086 mnemonic display shows disassembled instructions entering the 8086 queue. In this illustration instructions that enter the queue but are not executed are flagged with question marks. Operands for which there is no data (as when the instruction is flushed before the operand is retrieved) are marked with asterisks.

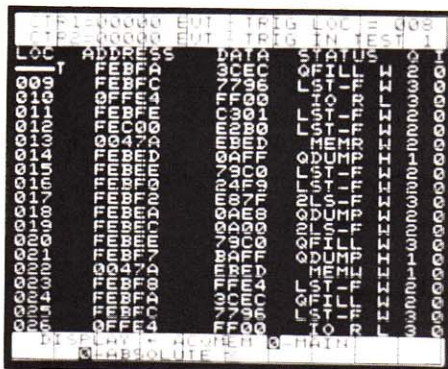

8086 State Table Display

SYSTEM CHARACTERISTICS

MAXIMUM SETUP AND HOLD TIMES (Min and Max Modes)

| Parameter | Setup | Hold | Units | Notes |
|-----------|-------|------|-------|---|
| Address | 45 | 20 | ns | Relative to falling edge of ALE |
| Data | 30 | 0 | ns | Relative to falling edge of clock on T ₄ state |
| Ready | 80 | 0 | ns | Relative to falling edge of clock at T ₃ or T ₄ TRYLCL, TRYHCH, TCHRYX |

All Maximum Mode Status Lines, Series Resistance: 10 Ω additional.

SIGNAL TIMING, MINIMUM MODE (Synthesized)

| Parameter* | Typical | Max | Min | Units |
|--------------------------|---------|------|-----|-------|
| ALE falling edge (TCHLL) | 40 | 55 a | - | ns |
| ALE width (TLHLL) | - | - | 60 | ns |
| M/I/O (TCHCTV) | 33 | 110 | - | ns |
| INTA (TCHCTV) | 68 | 110 | - | ns |
| DT/R (TCHCTV) | b | c | - | ns |
| DEN (TCVCTV) (TCVCTX) | 63 | 80 | - | ns |
| WR (TCVCTV) (TCVCTX) | 45 | 80 | - | ns |
| HLDA | d | e | - | ns |

*Names Given by Intel 8086 Users Manual.

a. 0 ns after falling edge of clock for T2 cycle.

b. Clock high width plus 33 ns.

c. Clock high width plus 100 ns.

d. Equal to or greater than 1 clock width plus 33 ns.

e. Greater than 1 clock width plus 100 ns.

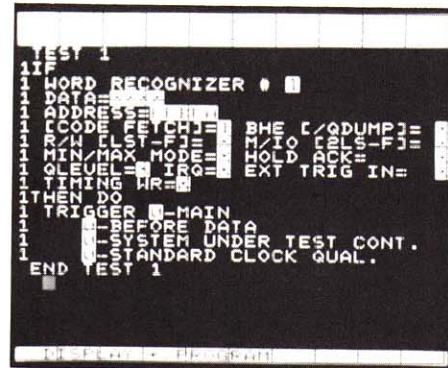

8086 Default Trigger Menu

| Control Name and Function | Stored | Word Recog | Clock Qualifier |
|--|--------|------------|-----------------|
| C0 R/W [LST-F]. When C2 is low, C0 indicates R/W status - when C2 is high C0 denotes when the last byte out of the instruction queue was the first byte of an executed instruction. | X | X | |
| C1 M/I/O [2LS + F]. When C2 is low, C1 indicates whether present operation is a memory or input-output access. When C2 is high, C1 goes high, when the second to the last byte of the instruction queue was the first byte of an executed instruction. | X | X | |
| C2 Code fetch goes to a high whenever an instruction is being fetched. | X | X | |
| C3 IRQ - is the combination of INTR and NMI | X | X | |
| C4 Min/max indication | | X | X |
| C5 HOLD Acknowledge | | X | X |
| C6 /Code fetch | | | X |
| C7 HOLD acknowledge line provides visual indication of a HOLD acknowledge condition on the screen when 7D02 is running | | | X |
| C8 Machine state (T1) | | | X |
| C9 /Wait | | | X |

A20-23 provide queue level information and BHE.

ORDERING INFORMATION

PM106 \$1800

PM106 Option 01 With Service Test Unit Add \$500

PM107 \$1800

PM107 Option 01 with Service Test Unit Add \$500

Or Service Test unit may be ordered separately:

067-1024-00 without power supply \$500

PM108 Z8002 Personality Module

SYSTEM CHARACTERISTICS

SETUP AND HOLD TIMES (MAX)

| Parameter | Setup | | Hold | | Units |
|--------------|-------|-----------------|------|-----|-------|
| | Min | Max | Min | Max | |
| Address 0-15 | — | 34 ^c | — | 0 | ns |
| Data 0-15 | — | 40 ^a | — | 0 | ns |
| READ/WRITE | — | 40 ^a | — | 0 | ns |
| I/O/MEM | — | 40 ^a | — | 0 | ns |
| INTREQ | 160b | — | — | — | ns |
| IFC | — | 40 ^a | — | 0 | ns |
| /BUSAK | — | 40 ^a | — | 0 | ns |
| /MREQ | — | 40 ^a | — | 0 | ns |
| /RESET | — | 40 ^a | — | 0 | ns |
| /PHALTED* | — | 40 ^a | — | 0 | ns |
| /AS | — | 40 ^a | — | 0 | ns |
| /WAIT | — | — | — | — | — |

a. Referenced to falling edge of T3.

b. Latched at falling edge of T2. Held until cleared by interrupt acknowledge cycle.

c. Latched at rising edge of /AS.

*The "OR" of Z8002 stopped and 7D02 HALT.

Order PM108 \$1800

NEW
PM109 68000 Personality Module

The PM109 solves the major problem in debugging 68000 based systems by flagging prefetched but unexecuted instructions.

SYSTEM CHARACTERISTICS

SETUP AND HOLD TIMES (MAX)
(With Respect to Falling Edge of Clock)

| Parameter | Setup | Hold | Units |
|-----------------|-------|------|-------|
| Address | 45 | 20 | ns |
| Data | 20 | 20 | ns |
| /UDS | 50 | 20 | ns |
| /IPL0/IPL1/IPL2 | 40 | 0 | ns |
| /DTACK | 25 | 0 | ns |
| /HALT | 40 | 0 | ns |
| /AS | 30 | 0 | ns |
| /BGACK | 40 | 0 | ns |
| /Reset | 20 | 0 | ns |

| Control Name and Function | Stored | Word Recog | Clock Qualifier |
|---------------------------|--------|------------|-----------------|
| C0 (FL-IACK) LDS | X | X | |
| C1 (OPC/EXT) R/W | X | X | |
| C2 (Fetch) | X | X | |
| C3 SUPER/USER | X | X | |
| C4 /BGACK | | X | X |
| C5 /INTR | | X | X |
| C6 /AS | | | X |
| C7 /HALT | | | X |
| C8 /DTACK | | | X |
| C9 /As sampled | | | X |

*Note: Not recommended that these lines be used for clock qualification.

ORDERING INFORMATION

When ordering, please use the exact nomenclature given here:

PM109 \$2000

For PM109 and Service Test Unit:

PM109 Opt 01 Add \$1200

Or the Service Test Unit can be ordered separately:

067-1025-00 \$1200

NEW
PM110 Z8001 Personality Module

SYSTEM CHARACTERISTICS

SETUP AND HOLD TIMES (MAX)

| | Setup | Hold | |
|--------------------------|--------|-------|--|
| Data | 32 ns | 3 ns | Relative to the falling edge of clock at T3 |
| Address | 15 ns | 23 ns | Relative to rising edge of AS |
| SNO-SN6 (segment inputs) | 25 ns | 25 ns | Relative to rising edge of AS |
| N/S (normal/system) | 86 ns | 0 ns | Relative to the falling edge of the clock at T3 |
| AS | 78 ns | * | Relative to the rising edge of the clock at T2 |
| R/W | 65 ns | 0 ns | Relative to the rising edge of the clock at T2 |
| ST0 - ST3 | 65 ns | 0 ns | Relative to the rising edge of the clock at T2 |
| Wait | 55 ns | 24 ns | Relative to the trailing edge of the clock at T2 or TWA for memory or I/O cycles, and at TWA3 or TWA5 for acknowledge cycles |
| MO,BUSAK | 85 ns | 0 ns | Relative to the trailing edge of the clock at T3 |
| VI,NVI | 110 ns | 0 ns | Relative to the trailing edge of the clock at T3 |
| SEGT | 85 ns | 0 ns | Relative to the trailing edge of the clock at T3 |
| NMI | 110 ns | ** | |

Notes:
*minimum pulse width — 42 ns.
**minimum pulse width — 28 ns.

| Control Name and Function | Stored | Word Recog | Clock Qualifier |
|--|--------|------------|-----------------|
| N/S Normal/System | X | X | |
| C0 Encoded - Read/Write - Low on writes, refresh and Interrupt ACK cycles | X | X | |
| C1 Encoded - High on I/O, Interrupt ACK and Fetch n. Low on memory, Fetch 1, EPA transfer, reserved in— ternal operation and re fresh cycles | X | X | |
| C2 Encoded - High on Fetches, Interrupt ACK and refresh cycles | X | X | |
| C3 Interrupt request - combined NMI, V1, NV1 and SEGT(active high) | X | X | |
| C4 Low on EPA, EPN and /MO read or write cycles | | X | X |
| C5 True Z8001 R/W signal | | X | X |
| C6 Low on internal operations, refresh and bus acknowledge cycles | | | X |
| C7 Halt-Low indicates the processor is halted. The PM110 uses the proces sor/stop signal and the Z8001 continues to ex ecute refresh cycles | | | X |
| C8 /Wait - used to qualify out wait states | | | X |
| C9 General clock qualifier - generated by the PM110 (active high) | | | X |

When ordering, please use the exact nomenclature given here:

Order PM110 \$1800

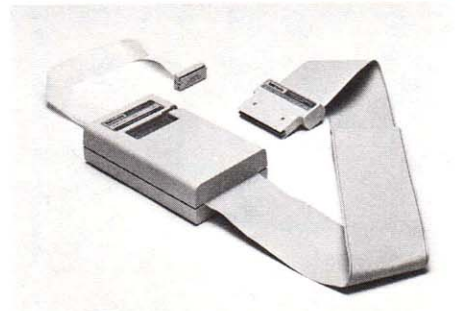

NEW
PM111 6809/6809E Personality Module

The TEKTRONIX PM111 Personality Module is a dedicated acquisition module designed for use with 6809 microprocessor-based systems. By using the convenient Tektronix Low Profile Dip Clip Adapter, the PM111 will also support the 6809E-based systems.

SYSTEM CHARACTERISTICS

SETUP AND HOLD TIMES (MAX)

| Parameter | Setup | Hold | Unit |
|--------------|-------|------|------|
| ADDRESS | 220 | 0 | ns |
| DATA | 40 | 10 | ns |
| R/W | 140 | 0 | ns |
| BA | 190 | 0 | ns |
| BS | 160 | 0 | ns |
| / (BMA/BREQ) | 120 | 0 | ns |
| /NMI | 155* | 0 | ns |
| /IRQ | 95* | 0 | ns |
| /FIQ | 95* | 0 | ns |

All lines are measured from the source of the signal with respect to the falling edge of E at the ZIF socket.

*NOTE: All PM111 Interrupt lines are sampled on the falling edge of E in contrast to the Motorola spec of sampling on the falling edge of Q.

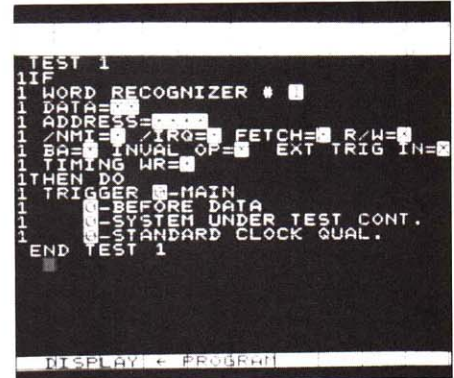

6809 Default Trigger Menu

| Control Name and Function | Stored | Word Recog | Clock Qualifier |
|---------------------------|--------|------------|-----------------|
| C0 READ/WRITE | X | X | |
| C1 /IFC | X | X | |
| C2 /(IFC + IFC2) | X | X | |
| C3 INT | X | X | |
| C4 BA | | X | X |
| C5 /IOCO | | X | X |
| C6 /VMA | | | X |
| C7 (HALT)DMA/BREQ) | | | X |
| C8 DMA + DEAD | | | X |

*NOTE: This line useful for word recognition only; not recommended for clock qualification purposes.

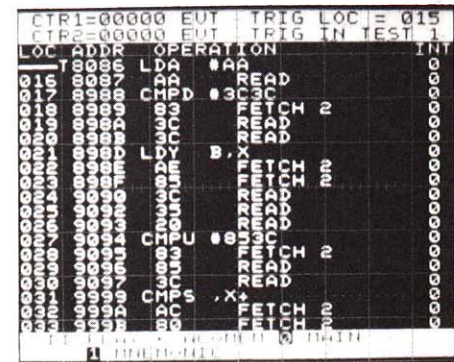

6809 Mnemonic Display

ORDERING INFORMATION

When ordering, please use the exact nomenclature given here.

PM111 \$1600

40 Pin Low Profile Dip Clip Adapter Numbers 10 cm Version

015-0339-00 (Recommended) \$40

Female Adapter 380-0647-01 \$25

40 Pin Dip Socket 136-0623-00 \$2.40

COMMON CHARACTERISTICS

Operating Temperature — -15 to +55°C except for PM109 which is 0 to 50°C.

Storage Temperature — -62 to +85°C except for PM109 which is -55 to +75°C.

Operating Altitude — 4.5 km (15,000 ft).

Storage Altitude — 15 km (50,000 ft).

Size — 12 cm X 20.3 cm X 4.3 cm except for PM106, 107, PM109 and PM111 which are 12 cm X 20.3 cm X 4.8 cm.

Weight — ≈ 1.2 kg.

Cable Length —

Module to 7D02 — 122 ± 2.5 cm.

Module to μP — 33 cm ± 1.2 cm except for PM101 which is 35 cm and PM111 which is 47 cm ± 1.3 cm

Display Formatters

There are two Display Formatters available with the 7D01 Logic Analyzer—the DF1 and DF2. Both offer Timing, Mapping, and State Table Displays in Binary, Hexadecimal and Octal formats. The DF2 offers additional formats for IEEE-488/GPIB and ASCII.

The Display formatters are dedicated for use with the 7D01. They provide complete alphanumeric character generation, so that the logic analysis package can be used in mainframes without CRT readout (mainframe Option 01).

There are also two modes of automatic data acquisition in the DF1 and DF2 which compare the entire 7D01 memory to the reference memory. If a difference is detected, the difference and location will be intensified in the display, read out at the top of the CRT, and the number of resets required to find the error will be displayed. This function, called RESET IF 7D01 = REF, allows full comparison of stored and newly acquired data. To compare only the tables selected by the cursor control, use RESET IF TABLES = .

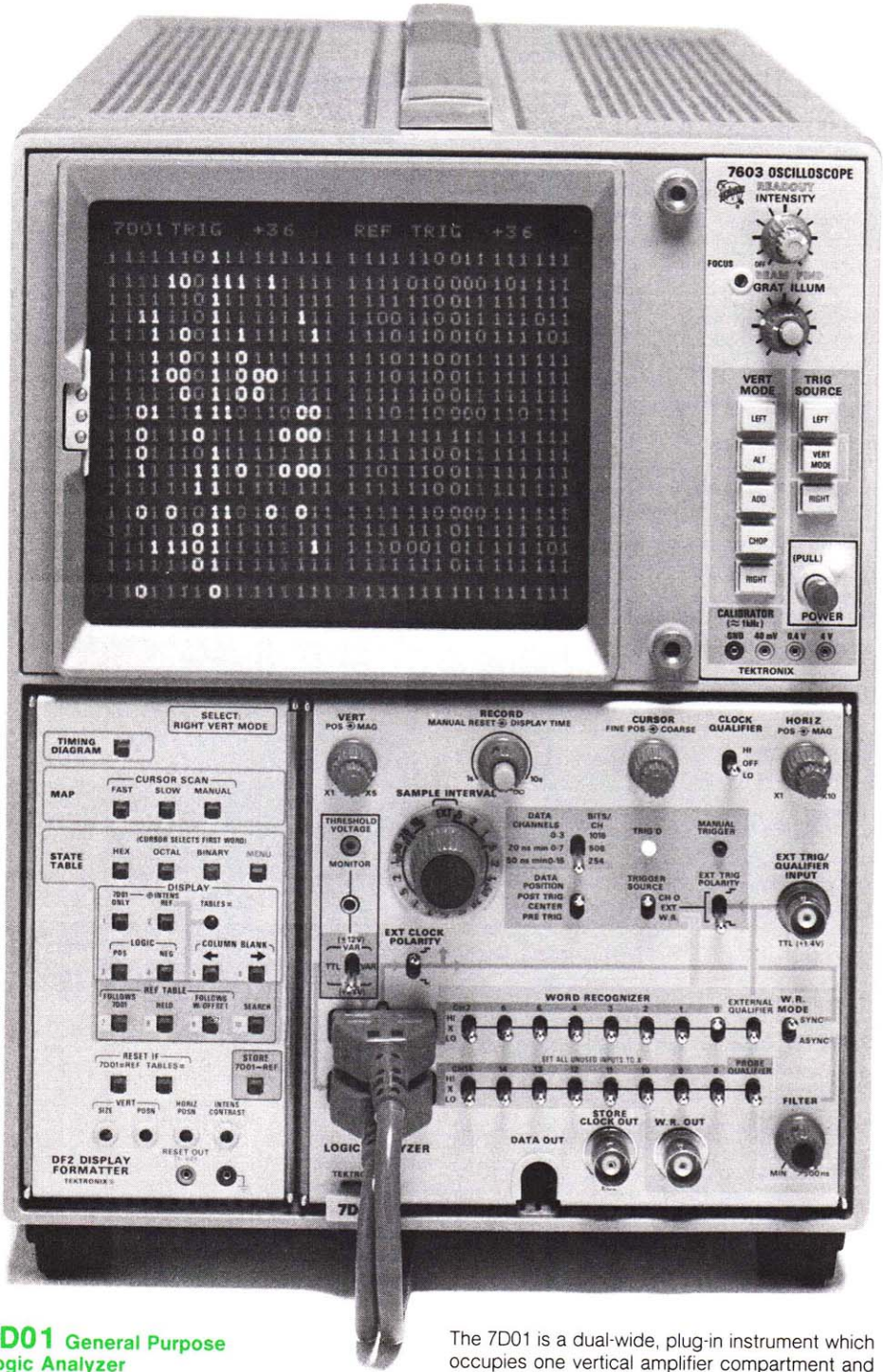

| 7D01 TRIG +24 | REF TRIG +19 |
|---------------|--------------|
| C563 | 793E |
| 2364 | F93F |
| A565 | 0560 |
| 6566 | 8561 |
| E567 | 4562 |
| 1568 | C563 |
| 3569 | 2564 |
| 556A | A565 |
| D56B | 6566 |
| 356C | E567 |
| 156D | 1568 |
| 756E | 9569 |
| F56F | 556A |
| 8070 | D56B |
| 8071 | 356C |
| 4072 | 856D |
| C073 | 756E |
| D12B | TRIG |
| | D12B |

Digital Latches

The DL2 and DL502 Digital Latches extend the 7D01 Logic Analyzer's measurement capabilities by detecting narrow pulses in a data stream that cannot be captured by a logic analyzer alone. Operating in an asynchronous mode, the 16 channel Digital Latches can detect spikes or glitches between system clock edges that are narrower than the sample clock interval or as narrow as 5 ns.

7D01 General Purpose Logic Analyzer

- 16 Stored Channels
- Up to 1024 Words Deep
- State or Timing
- Up to 100 MHz Sample Rate
- High Impedance Probes
- 18 Bit Word Recognizer
- Clock Qualifier

The 7D01 is a dual-wide, plug-in instrument which occupies one vertical amplifier compartment and an adjacent time base compartment in any 7000 Series Oscilloscope Mainframe. With this compatibility, you can configure a total logic analysis system. Using a four-wide mainframe oscilloscope, you can combine your logic analyzer with your analog oscilloscope and display the outputs of both at the same time.

7D01 CHARACTERISTICS

The 7D01 acquires 4, 8, or 16 Ch of data and stores the data in a 4 k memory. Data storage format is selectable as 4 Ch X 1016 bits, 8 Ch X 508 bits, or 16 Ch X 254 bits.

Data sampling can be asynchronous (internal clock) or synchronous (external clock). In asynchronous modes, sampling rates can be selected up to 100 MHz in the 4 Ch mode, up to 50 MHz in the 8 Ch mode, or up to 20 MHz in the 16 Ch mode. External sampling clocks up to 20 MHz can be used in the 4 and 8 Ch modes, and up to 25 MHz in the 16 Ch mode.

SIGNAL INPUTS

Clock, Qualifier, and Data Input Source—Two multi-lead P6451 Probes provide connections for 9 Ch (9 input and ground) each. Ch 0-7 and clock are through probe 1, and Ch 8-15 and qualifier are through probe 2. Each probe attaches through a 25 pin connector at the 7D01 front panel.

| Clock Qualifier — | Setup | Hold |
|-------------------|-------|------|
| P6451 | 20 ns | 0 ns |
| *External | 11 ns | 7 ns |

*Measured at external BNC jack. For 0 ns hold time, 42 inch BNC coaxial cable is recommended.

Input Impedance — 1 MΩ paralleled by 5 pF (at probe head).

Threshold at Probe Tips — Front panel switch selects fixed TTL (+1.4 V ± 0.2 V), variable (± 12 V) or split (variable for top probe, TTL for bottom probe). Front panel jack monitors variable threshold only.

Minimum Logic swing — 500 mV plus 2% of threshold voltage p-p or less, centered on the threshold voltage.

Maximum Logic Swing — -40 V or less, to at least threshold voltage plus 10 V. (Max non-destructive input ± 40 V.)

MEMORY

Storage — 4096 bits.

Format — Front panel selectable.

| Data Channels Displayed | Bits per Channel |
|-------------------------|------------------|
| 0-3 | 1016 |
| 0-7 | 508 |
| 0-15 | 254 |

SAMPLING RATE

Asynchronous (internal clock) — Sampling intervals are selectable from 10 ns to 5 ms in 18 steps using a 1-2-5 sequence.

| Data Channels Displayed | Maximum Sampling Rate | Minimum Sampling Interval* | Min. Data Pulse Width* |
|-------------------------|-----------------------|----------------------------|------------------------|
| 0-3 | 100 MHz | 10 ns | 15 ns |
| 0-7 | 50 MHz | 20 ns | 25 ns |
| 0-15 | 20 MHz | 50 ns | 55 ns |

*Minimum data pulse width to insure recording is one sample interval + 5 ns.

Synchronous (external clock) — + or - edge of clock pulse can be selected to initiate sample.

| Data Channels Displayed | Max. Clock Freq. | Minimum Clock Width* | Data Set-up Time Required | Data Hold Time Required |
|-------------------------|------------------|----------------------|---------------------------|-------------------------|
| 0-3 | 50 MHz | 10 ns | 20 ns | 0 |
| 0-7 | 50 MHz | 10 ns | 20 ns | 0 |
| 0-15 | 25 MHz | 20 ns | 23 ns | 0 |

*High and low clock width.

WORD RECOGNIZER

Word Recognizer — 16 data inputs, Probe Qualifier and External Qualifier. Output is true when input conditions match settings (HI, X, LO).

Asynchronous Mode

| Format | Minimum Input Pulse Width (Asynchronous Mode) |
|-----------------------|---|
| Any Single Channel | 10 ns or less |
| Channels 0-3 | 15 ns or less |
| Any Other Combination | 20 ns or less |

Synchronous Mode

| Characteristic | Time Requirement |
|--------------------|------------------|
| Minimum Setup Time | 12.5 ns or less |
| Minimum Hold Time | 8.5 ns or less |

Async Filter — Rejects recognized words that remain true for less than an operator selected time period. Period is variable from 10 ns to 300 ns.

W.R. Out Connector — A recognized word produces a display trigger marker and a front panel output for triggering external circuitry.

| Characteristic | Requirement |
|-------------------------|-------------|
| HI Level | ≥ 1.9 V |
| LO Level | ≤ 0.1 V |
| Impedance (Rising Edge) | 50 Ω ± 10% |

TRIGGER

Source — Three-position switch provides selection of trigger source from among channel 0, external (External Trigger/Qualifier Input), or internal word recognizer. A display can also be obtained with front panel MANUAL TRIGGER pushbutton.

Channel 0 — Triggers on rising edge of CH 0 data.

External Trigger/Qualifier Input Connector (EXT TRIG-/QUALIFIER INPUT) —

| Characteristics | Requirement |
|----------------------------|---------------------------------|
| Threshold | +1.4 V, ± 0.2 V (TTL Level) |
| Minimum Pulse Width | 15 ns |
| Maximum Safe Input Voltage | -5 V or less, to at least +10 V |

Triggered Light — Indicates display trigger has occurred.

CURSOR

Word Selection — Cursor appears as a movable second intensified spot on the CRT display. It is used to select and mark a word.

Coarse and Fine Position Controls — Coarse control moves cursor in increments of 16 sample intervals. Fine control moves cursor in increments of 1 sample interval.

Cursor to Trigger Position CRT Readout — The difference in sample interval bits between cursor position and trigger position is displayed by the CRT readout at the top, right-hand portion of the CRT graticule (e.g., TRIG ± XXX).

Cursor Position Binary Data — The logic state of each displayed channel coincident with the cursor position is displayed in Binary by the readout at the bottom of the CRT (HI = 1, LO = 0).

Trigger Intensified Marker — Intensified zone indicating the trigger point, selectable by a switch (DATA POSITION).

| Data Position Switch Setting | Intensified Zone Location |
|------------------------------|-------------------------------|
| Pre-trigger | Near extreme right of display |
| Center-trigger | Near center of display |
| Post-trigger | Near extreme left of display |

Trigger Intensified Marker Accuracy — Position of intensified zone with respect to word recognizer output.

| Sample Interval Control Setting | Maximum Bit Error |
|---------------------------------|-------------------|
| 10 ns | ± 4 bits |
| 20 ns | ± 3 bits |
| 50 ns to 5 ms | ± 1 bit |

POWER

Line Voltage Ranges — Determined by the 7000 Series Oscilloscope Mainframe.

Power Consumption — 32 W at nominal line voltage.

ENVIRONMENTAL

Temperature — Operating: 0°C to + 40°C. Nonoperating: -40°C to +75°C.

Altitude — Operating: to 15,000 feet. Nonoperating: to 50,000 feet.

Vibration — With the 7D01 and DF1 or DF2 combined, frequency swept from 10 to 50 cps at one minute per sweep. Vibrate for 15 minutes along each of the 3 major axes at 0.015 inch total displacement. Hold 3 minutes at any major resonance, or if none, at 50 cps. Total time, 54 minutes.

Shock — Operating and nonoperating: 30 g's, 1/2 sine 11 s duration, 2 shocks in each direction along 3 major axes, for a total of 12 shocks.

INCLUDED ACCESSORIES

Two, P6451 Data Input Probes (010-6451-03).

DF1 CHARACTERISTICS

The DF1 reformats the output of the 7D01 in a choice of five display formats including Timing, Mapping and state table displays in Binary, Hexadecimal and Octal. It imposes no significant electrical characteristics on the 7D01 which affect measurement parameters.

DF2 CHARACTERISTICS

The DF2 reformats the output of the 7D01 in a choice of seven display formats including Timing, Mapping and state table displays in Binary, Hexadecimal, Octal, ASCII and IEEE-488/GPIB. It imposes no significant electrical characteristics on the 7D01 which affect measurement parameters.

INCLUDED ACCESSORIES

GPIB Probe Adapter for the P6451 (103-0209-00). (A 24 pin IEEE Standard Connector with quick connection to the P6451 Probe Head.)

DL2 CHARACTERISTICS

The 16 channel DL2 aids the 7D01 measurement capabilities by detecting narrow asynchronous pulses of less than one sample interval or as narrow as 5 ns in a data stream. The DL2 plugs into any compartment of a 7000 Series Mainframe. Two 25 pin connectors connect the DL2 with the 7D01. Data is acquired via two P6451 Probes which plug into the front panel of the DL2.

Minimum Pulse Width to Initiate Latch — 5 ns.

Minimum Amplitude to Initiate Latch — 500 mV centered at threshold.

Minimum Sample Interval Asynchronous Clock — 50 ns.

ORDERING INFORMATION

| | |
|---|---------------|
| 7D01F Logic Analyzer (7D01 and DF1 Display Formatter) | \$5600 |
| 7D01F2 Logic Analyzer (7D01 and DF2 Display Formatter) | \$6200 |
| 7D01 Logic Analyzer | \$4200 |
| DF1 Display Formatter | \$1700 |
| DF2 Display Formatter | \$2300 |
| DL2 Digital Latch | \$1800 |
| DL 502 Digital Latch | \$1600 |
| 7603 Oscilloscope* | \$2555 |
| Option 01 (Deletes one readout board) | Sub \$300 |
| 7704A Oscilloscope* | \$3995 |
| Option 01 (Deletes one readout board) | Sub \$300 |

To modify your present 7D01 to include the new clock qualifier feature order clock Qualifier* modification kit.

040-0891-00

\$170**
*See pages 155 through 175 in this catalog for details on these and additional 7000 Series Mainframes. See pages 183 through 204 for details on complementary 7000 Series Plug-ins.

**Price does not include installation.

ACQUISITION PROBES



P6406 Replacement Word Recognizer Probe — For SONY®/TEKTRONIX® 308 only
 (010-6406-01) \$490

P6107 Replacement Serial Data Probe — For SONY®/TEKTRONIX® 308
 010-6107-03 \$105

P6451 Replacement Active Probe — (010-6451-03) For 7D02 Option 01, WR 501, 7D01, 7D01F, 7D01F2. Two probes are needed for 16 channel operation \$525

(010-6451-05) For SONY®/TEKTRONIX® 308 only, with right-angle connector \$525

P6452 8 Channels Data Acquisition Probe. For DAS 9100.
 010-6452-01 \$700

P6453 4 Channels 300 MHz High Speed Data Acquisition Probe. For 91A04/91AE04.
 010-6453-01 \$1500

P6454 100 MHz Clock Probe. For 91A08.
 010-6454-01 \$250

OPTIONAL ACCESSORIES

Flying Lead Set, 5 in
 012-0987-00 (P6452) \$40

Flying Lead Set, 10 in (P6452)
 012-0746-00 \$15

Diagnostic Lead Set,
 012-1000-00 (P6452, P6455, P6456) \$75

Package of 10 ground (or VL) sense leads, 5 in, black with Pomona Hook Tip
 012-0989-01 (P6452, P6455, P6456) \$50

Package of 10 ground (or VH) sense leads, 5 in green with Pomona Hook Tip
 012-0990-01 (P6455, P6456) \$50

Package of 2 leads with grabber tips
 195-3659-00 (P6454) \$15

Package of 12 grabber tips
 020-0720-00 (P6451, P6452, P6455, P6456) \$33

Package of 10 flat pack high speed grippers
 195-1943-06 (P6453, P6454) \$75

Package of 10 dip pack high speed grippers
 195-2234-06 (P6453, P6454) \$75

BNC Cable — 50 Ω, 8 in
 (012-0076-00) (connect 7D01 to DL2) \$17

PATTERN GENERATOR PROBES

P6455 8 Channel TTL/MOS Pattern Generator Probe
 010-6455-01 \$550

P6456 8 Channel ECL Pattern Generator Probe
 010-6456-01 \$550

Pattern Generator Lead Set, 9 in
 012-0926-00 (P6455, P6456) \$65

High Speed Pattern Generator Lead Set, 5 in harmonica
 012-1001-00 (P6455, P6456) \$50

DIP CLIP ADAPTERS

40 Pin Low Profile Dip Clip — 10 cm cable (order M/F adapter below.)
 (015-0339-00) \$40

40 Pin Low Profile Dip Clip — 30 cm cable (order M/F adapter below.)
 (015-0339-02) \$40

Male Adapter for 40 Pin Low Profile Dip Clip — For use with PM101 7D02 General Purpose Personality Module (or with individual leads such as the 10-wide comb set 012-0747-00)..
 380-0560-05 \$15

Female Adapter for 40 Pin Low Profile Dip Clip — For use with dedicated 7D02 Personality Modules.
 380-0647-01 \$25

SPECIAL PURPOSE LEAD SETS

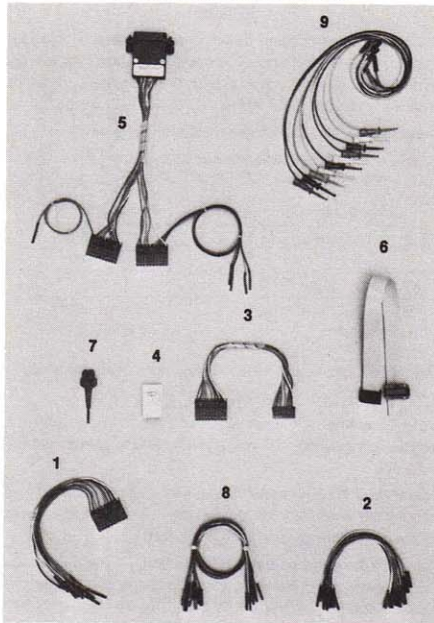

1. 10 Wide Comb — 10 in leads — grabbers not included.
 (012-0747-00) \$46

2. 20 cm Individual Connectors — Grabbers not included.
 (012-0655-02) \$70

3. 10 Wide Comb — With Harmonica Connector.
 (012-0800-00) \$30

4. Clothes Pin IC Clip —
 (003-0709-00) \$29

5. GPIB Connector —
 (103-0209-00) \$180

6. 16 Pin Low Profile Dip Clip — Can be used with 14 or 16 pin IC's.
 (015-0330-00) \$35

7. Grabber Tip —
 (206-0222-00) \$3.00

8. 40 cm, Color Coded Replacement Lead Set* — For the P6450 Probe or the P6451 Probe. 10 leads/set connects probe lead to 0.025 in, square pins.
 (012-0655-01) \$40

9. 40 cm Individual Connector* — 10 wire with Pomona Grabbers.
 (012-0670-00) \$65

*Note: EMI can exist with the 40 cm length. This can be a problem if using a digital latch.

Probe Holder — Clip-on holder accommodates probe pod for P6451.
 (352-0473-01) \$3.00

BNC Cable — Used with the Digital Latch
 (012-0118-00) \$16

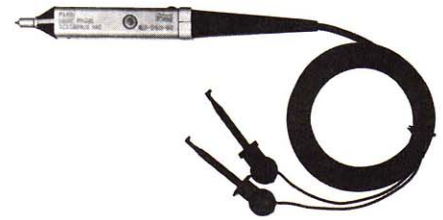

P6401 Logic Probe

The small, lightweight, hand-held P6401 indicates the state of logic levels in TTL, DTL, or any other system with threshold between 0.7 and 2.15 volts. A strobe input can be used to detect the coincidence of logic signals at two points. An indication of whether a logic pulse has or has not occurred can be obtained in a "store" mode.

Power may be obtained from the unit under test or any 5 V supply.

Two bright lights in the probe tip indicate condition of the logic signal.

CHARACTERISTICS

Low State Input Voltage Range — 0 V to +0.7 V ±0.125 V.
High State Input Voltage Range — 2.175 V ±0.125 V to V_{cc}.

Minimum Recognizable Pulse Width — 10 ns.

Impedance — ≈7.5 kΩ paralleled by ≈6 pF.

Minimum Circuit Resistance for Open Circuit Indication — 10 kΩ.

Max Safe Input — ±150 V (dc or RMS).

Minimum Recognizable Strobe Pulse Width — 20 ns.

Max Safe Strobe Input — ±30 V (dc or RMS).

Strobe Input Impedance — 5.6 kΩ within 20%.

Included Accessories — Hook Tip (206-0114-00), Strobe Lead (175-0958-01), Strobe Lead (175-0958-00), Probe Tip to 0.025 in square pin adapter (206-0137-01), White Plug (348-0023-00), 2 Alligator Clips (344-0046-00), Accessory Pouch (016-0537-00).

Order P6401 Logic Probe
 (010-6401-01) \$135

OSCILLOSCOPE PROBE ACCESSORIES

Accessories to aid in probing digital circuits with standard oscilloscope probes may be found on pages 338 and 339.

INFORMATION DISPLAY DIVISION

Vision is the most effective human channel of communication. Computer graphics translate computed data to quickly and easily understood visual forms. For statistical mapping or mechanical design, Tektronix provides monochrome and color displays, desktop computers, copiers, plotters, software and peripherals to answer the graphics needs of scientists and engineers. Mickey Westhoff, division sales manager for the Information Display Division presents two 4110 Series Computer Display Terminals, designed to be compatible with existing product lines and offer maximum efficiency with enhanced communications and local intelligence.



COMPUTER GRAPHICS PRODUCTS

CONTENTS

Computer Display Terminals

| | |
|-------------------------------------|----|
| 4112 | 70 |
| 4114 | 71 |
| 4014-1/4015-1 | 72 |
| 4016-1 | 73 |
| 4027A Color Graphics Terminal | 74 |
| 4025A | 75 |
| 4006/4010-1/4012 | 76 |
| PLOT 10 Graphics Software | 77 |
| 4041 Computer Controller | 78 |

Desktop Computers

| | |
|---------------------------------|----|
| 4054 | 79 |
| 4052/4051 | 80 |
| ROM Packs | 81 |
| PLOT 50 Graphics Software | 82 |

Peripherals

| | |
|--|----|
| 4909 Multi User File System | 84 |
| 4662 Interactive Digital Plotter | 85 |
| 4663 Interactive Digital Plotter | 87 |
| 4611 Hard Copy Unit | 88 |
| 4612 Hard Copy Unit | 89 |
| 4631 Hard Copy Units | 90 |
| 4632 Video Hard Copy Units | 90 |
| 4642 Matrix Printer | 91 |
| 4643 Matrix Printer | 91 |
| 4923, 4924 Digital Recorders | 92 |
| 4953, 4954, 4956 Graphic Tablets | 92 |
| 4952 Joystick | 92 |
| 4907 File Manager | 92 |
| 4634 Imaging Hard Copy Unit | 93 |

"The Graphic Standard"

Tektronix has set the standard in computer graphics for the past 13 years. We continue in the same tradition with the introduction of new products like the 4110 Series. Designed to be compatible with existing product lines, the 4110 Series offers enhanced communications and local intelligence for maximum efficiency. These new products join a broad range of graphics equipment including desktop computers, color and monochrome display terminals, hard copy and storage devices, graphics software and peripherals.

For additional product information and details on interfacing, software and accessory support, please indicate your interest on the reply card enclosed in your catalog.

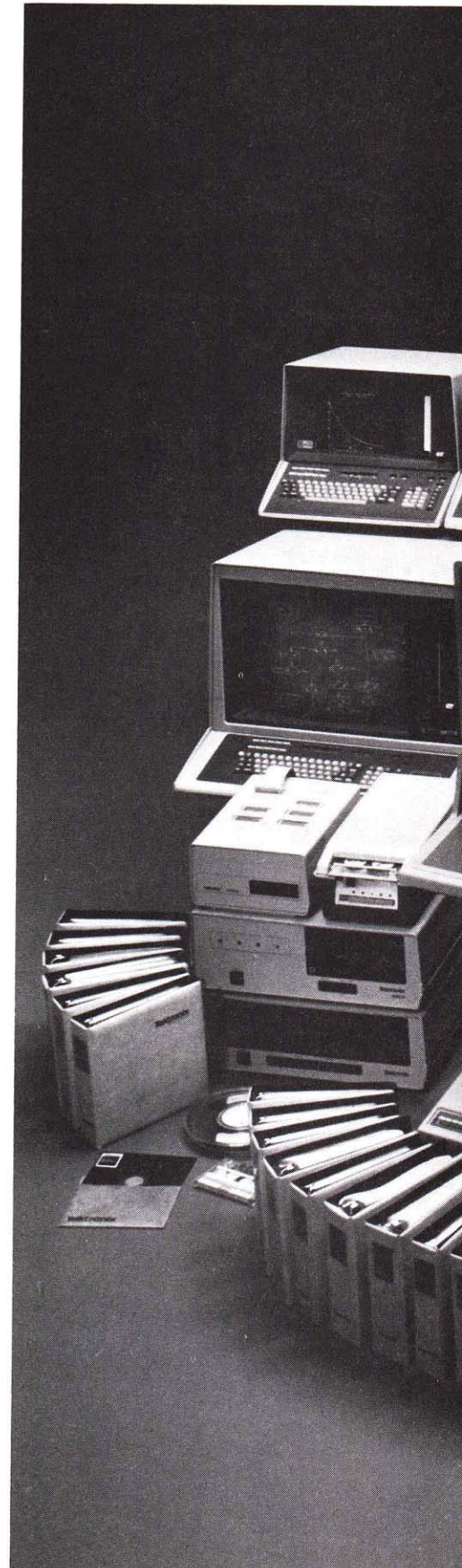



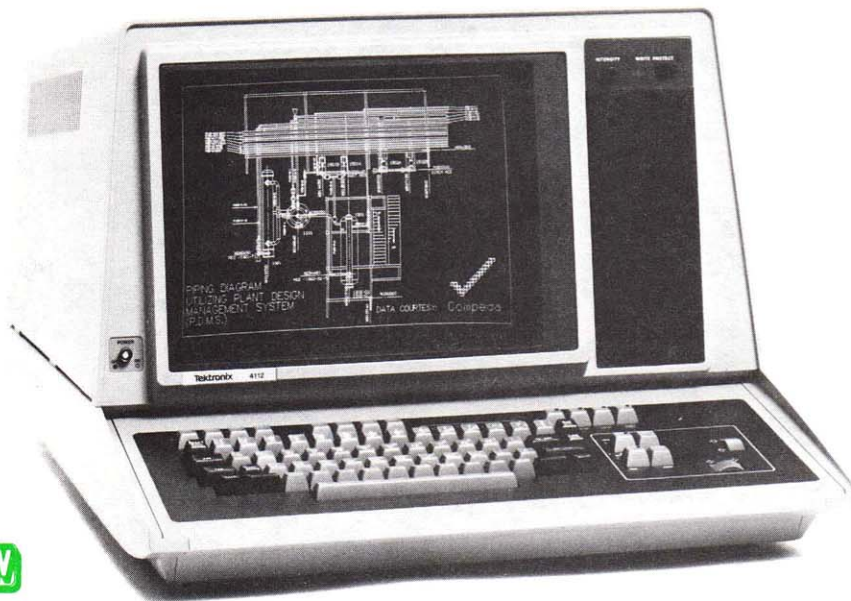

NEW

4112

Raster Scan Monochrome Display

Local Picture Segments

2-D Transforms, True Zoom and Pan up to 3 Memory Planes

Compatible with TEKTRONIX 4010 Series

New economies of communications traffic and CPU time. The 4112 capitalizes on many conveniences and special capabilities of a raster scan display. Designed to satisfy a broad range of evolving needs, from basic line graphs to high density design, the 4112 provides access to an unusually wide assortment of graphics capabilities. Its powerful local intelligence keeps user interactivity high and host dependency low.

The 4112 is designed to be compatible with the popular Tektronix 4010 Series of computer display terminals. Programs developed for the 4012 or 4014, for example, may require only minor software revisions—mostly to account for new expanded capabilities—in order to run on the 4112. By using the modular device drivers and advanced feature support of the TEKTRONIX PLOT 10 Interactive Graphics Library (IGL), updating existing programs for the new 4112 features is a simple process.

In addition, there is great commonality among all members of the new 4110 Series. The selection allows you to specify the best terminal for each need, without significant investment in increased operator training or software.

The 4112 offers a bright, flicker-free 381 mm (15 in) raster scan display with a viewable resolution of 640 x 480 points, augmented by 4096 x 4096 point addressability and by zoom and pan.

In addition, the user can specify as many as 64 viewports for simultaneous display of multiple design perspective, or for any other consolidated presentation of related information. Each viewport can be zoomed into and out of individually.

The 4112 incorporates several valuable local features that enhance user interactivity and graphics capacity, while radically reducing the load on the host and the volume of communications traffic. These features include:

Local picture segments. A local picture segment is a group of graphic primitives that describes a portion or segment of a picture. These primitives are retained in the terminal's memory to be redrawn and manipulated at any time by using the 4112's local "segments" capability. Eight programmable function keys are provided for user-definable functions that may be used locally.

Schematic components, symbols, titles and text can be defined as segments, for example, then stored in local memory and redrawn when needed, with minimal computer time and communications traffic required.

2-D Transforms. Local segments may also be rotated, scaled or moved around the screen, by a simple command from the host processor.

Zoom and pan. An addressable display space of 4096 x 4096 points is accessible locally by simple, key-actuated zoom and pan or via the host. The thumbwheel controls are used to pan the display with a rectangular cursor and to set the viewport dimensions of the magnified image.

Multiple display memory planes. Optionally, two additional bit map buffers, or memory planes, may be added to the 4112, providing as many as three display surfaces. This capability enables a number of effects, including overlays of text and/or graphic information.

Tektronix offers maintenance training classes on instruments in the 4112 Intelligent Terminal. For further training information, contact your local Sales Office or request a copy of the Tektronix Customer Training Catalog on the return card.

Secondly, the memory planes can be used to create gray scale effects, with up to eight shades of gray/displayable at once. A panel flooding feature enables easy fill-in of closed figures with gray scale or with patterns.

Definable dialog area. At any time, the user can specify the size and position of the region where communications between terminal and host are displayed. This dialog area is scrollable by the thumbwheels, allowing for easy recall of previous communications.

Memory. The standard 4112 memory consists of 32k bytes of RAM and 72k bytes of ROM. It is expandable incrementally up to a total of 672k bytes RAM.

An optional, integral flexible disk drive can be specified to add a total 494k bytes per disk of off-line mass storage with disk drive.

CHARACTERISTICS

DISPLAY

Medium — Raster-scan CRT.

Display Area — 220 mm x 254 mm (8.6 in x 11.5 in).

Phosphor Type — White P4.

Scan Type — 60 Hz non-interlaced or 50 Hz non-interlaced (optional).

KEYBOARD

Normal Keyboard — 72 typewriter paired upper and lower case, programmable and auto repeating (seven lighted).

8 user-definable programmable function keys, 4 terminal control keys, and 4 special keys for zoom and pan functions.

Other Controls — Thumbwheels control graphic cursor, zoom-pan function, and scrolling.

ALPHANUMERIC MODE

Standard Character Set — Full ASCII set of 94 displayable characters.

GRAPHICS MODE

Resolution — 640 horizontal by 480 vertical pixels.

Addressability — 4096 x 4096 points.

Gray Scale — Eight levels of gray scale are provided if two optional (three total) memory planes are included.

Interactive Graphics — Thumbwheels in the keyboard control a graphic cursor. The graphic cursor may have its shape defined by the user (with hardware cross-hairs as default). The user can also control zooming, scrolling, and the alpha cursor position by keyboard keys.

Computer Interfaces — Basic data communications interface, EIA RS-232C compatible, full or half-duplex.

Flexible Disk Characteristics — (Option 42)

8 in single-sided double-density disk.

Direct memory access.

ORDERING INFORMATION

4112 Computer Display Terminals \$9600
Option 42 Add \$2800

INTERNATIONAL POWER CORD AND PLUG OPTIONS

Option A1 Universal Euro 220 V/16A No Charge
Option A2 UK 240 V/13A No Charge
Option A3 Australian 240 V/10A No Charge
Option A4 North American 240 V/15A No Charge



NEW

4114

Direct View Storage Tube

Local Picture Segments

2-D Transforms, Refresh Support and Fast Redraw

Compatible with TEKTRONIX 4010 Series

New standards of fast graphics throughput. Enhanced user interactivity with reduced host overhead. The 4114 has been designed to satisfy the evolving needs of graphics users for faster, more versatile throughput in high density graphics applications. Its local intelligence and expandable memory can significantly reduce the delays and costs associated with over-dependence on the host computer.

The 4114 has been designed to be compatible with the popular TEKTRONIX 4010 Series of computer display terminals. Programs developed for the 4014, for example, may require only minor software revisions—mostly to account for expanded capabilities—in order to run on the 4114. By using the modular device drivers and advanced feature support of the TEKTRONIX PLOT 10 Interactive Graphics Library (IGL), updating existing programs for the new 4114 capabilities is a simple process.

In addition, there is a great commonality among all members of the new 4110 Series: project teams can share programs and peripherals while utilizing the 4110 Series terminal best suited for each application's need.

The display: more to see than ever. The 4114 is designed around a 483 mm (19-inch) direct-view bistable storage tube. Its 4096X by 4096Y addressable points (4096X by 3120Y displayable points) provide resolution high enough for the most complex engineering and scientific graphics. The 4114 offers enhanced text display with as many as 16 hardware-generated sizes of stroke upper-and-lower case ASCII characters. A large number of dot-dash line styles and markers, plus rubberbanding capability, simplify graphics development. Thumbwheel-controlled symbols enable easy placement and revision of display elements.

An intelligent evolution of graphics efficiency. Through its advanced local intelligence and its capacity to do much more per host command, the 4114 achieves new standards of productivity. Specific features of this intelligence include:

Local picture segments. A segment is a group of graphic primitives describing a portion or segment of a picture, retained as a unit in local memory to be redrawn or manipulated at any time by using the 4114's local "segments" capability.

2-D transforms. Local segments can be rotated, scaled or moved around the screen, with only a simple command from the host.

Refresh support. More than 1500 cm or approximately 3000 short vectors of flicker-free refresh.

Color enhanced refresh option for easy recognition of refresh information, for high density applications and those with a great deal of refresh manipulation, the Color Enhanced Refresh (Option 31) presents all refresh vectors in amber, for clear contrast with stored vectors.

Memory. Standard 4114 memory includes 32k bytes of RAM and 56k bytes of ROM. RAM memory is expandable up to 800k bytes total.

Fast redraw augments the powers of local intelligence. 26,000 short vectors may be redrawn in under 1/2 s.

Definable, refresh dialog area. The user may define the size and location of a scrollable dialog area—all in refresh. This area can be redefined and repositioned at any time.

Mass storage option. Single or dual integral flexible disk drive mass storage may be specified, for convenient local storage of segments, fonts, macros, and completed graphic displays. Each disk offers a 494k byte capacity.

CHARACTERISTICS

DISPLAY

Medium — Direct view storage tube 4096 x 4096 addressable points; 4096 x 3120 displayable points; Enhanced refresh; Fast redraw

Display Area — 368.3 mm x 276.9 mm (14.5 in x 10.9 in).

KEYBOARD

Normal Keyboard — 72 typewriter paired upper and lower case, programmable and auto repeating, (five lighted).

Eight user-definable programmable function keys.

Thumbwheels to control graphic cursor

ALPHANUMERIC MODE

Standard Character Set — Full ASCII set of 94 displayable characters.

Flexible Disk Characteristics — (Options 42 and 43)

8 in single-sided double-density disk.

IBM compatible soft-sectored recording format.

Cyclic redundancy checking and automatic data recovery retry for reliability.

Direct memory access.

ORDERING INFORMATION

4114 Computer Display Terminals . \$17,500

Option 31 Color Enhanced Refresh Add \$2000

Option 42 Single Flexible Disk and

Disk Controller Add \$2800

Option 43 Dual Flexible Disk and Disk Controller Add \$4200

INTERNATIONAL POWER CORD AND PLUG OPTIONS

Option A1 Universal Euro 220 V/16A No Charge

Option A2 UK 240 V/13A No Charge

Option A3 Australian 240 V/10A No Charge

Option A4 North American 240 V/15A No Charge

Tektronix offers maintenance training classes on instruments in the 4114 Intelligent Terminal. For further training information, contact your local Sales Office or request a copy of the Tektronix Customer Training Catalog on the return card.

4014-1/4015-1

483 mm (19 in), Direct-View Storage Display

Selectable Formats in Alphanumeric and Graphic Modes

High-Resolution, Interactive Graphics Capability

Plug-In Intelligence Options

APL Character Set Available



We've added some intelligent choices to the choicest of graphics. Tektronix' famous 4014-1 has long been a favorite for display of large data bases and precise detail. Its flicker-free 483 mm (19 in) screen offers priced-right performance for applications in mapping, design, manufacturing, medicine, energy exploration and many other diverse disciplines.

Firmware options provide up to 26k of graphics memory for local symbols, stroke-drawn characters, overlays, or background graphics which can be redisplayed on command from the host or keyboard. Reduce data transmission as you redraw portions of your graphics from local memory and generate circles and arcs by a single command. Add local scaling, rotation, and clipping of graphics. Buffered communications with the host and keyboard. Reduce CPU connect-time through local control of graphic tablets, plotters, and tape and disk storage. A variety of optional intelligence designed to help you keep up with new methods in mapping, process layout, financial graphing and many other applications.

Big Screen. Big Features. The 4014-1 and 4015-1 offer 1024 (X) by 780 (Y) displayable points standard and up to 4096 (X) by 3120 (Y) displayable points with the optional Enhanced Graphics Module. Its 12 million point capability is more than sufficient to solve most complex mapping and design tasks. Full 96-character ASCII includes four program-selectable alphanumeric formats which display up to 8512 characters at once.

Of course, the 4014-1 and 4015-1 are immediately compatible with the full range of Tektronix peripherals, including the 4631 and 4611 Hard Copy Units, the 4923 Digital Cartridge Tape Recorder, B-Size 4662 and C-Size 4663 Interactive Digital Plotter, plus others. Optional minibus extender allows expanded accessory and peripheral capability. And TEKTRONIX PLOT 10 Software provides a library of proven graphics packages. PLOT 10 offers versatile modular software for all levels of users. PLOT 10 Terminal Control System to link to existing applications, PLOT 10 Easy Graphing for rapid generation business or scientific graphs. For device independent applications projects add our PLOT 10 Interactive Graphics Library.

Previews and overviews. Interactive previewing on the 4014-1 can lop considerable time off normal plotter trial-and-error. As a cartographer's tool, for instance, the 4014-1 will draw precise maps of cities, states, and land formations, and isolate and enlarge those areas you choose.

The 4014-1 has become standard equipment to many phases of research, medicine, engineering, business, energy-related fields, cartography, manufacturing and others where its price/performance practically lends itself.

CHARACTERISTICS

Display Medium — Direct View Bistable storage CRT.

Display Area — 381 mm x 279 mm (15 in x 11 in).

Alphanumeric Mode — 4014-1 Full ASCII character set (94 printing characters).

4015-1 Full ASCII and APL character sets (188 total printing characters).

Character Format — Four program-selectable formats:

- 1) 74 characters per line with 35 lines per display.
- 2) 81 characters per line with 38 lines per display.
- 3) 121 characters per line with 58 lines per display.
- 4) 133 characters per line with 64 lines per display.

Alphanumeric Cursor — 7 x 9 dot pulsating cursor.

Keyboard — Typewriter paired upper and lower case with auto repeating keys 4015-1 adds APL character set.

Graphics Mode — Vector drawing time 5,000 in/s (127 m/s).

Information Density — 1024 (X) by 1024 (Y) addressable points (10 bits). 1024 (X) by 780 (Y) viewable points.

Interactive Graphic Mode — Thumbwheel controlled crosshair cursor. 3 thru 1024 addressable points horizontally. 0 thru 780 addressable points vertically.

Computer Interfaces — Basic Data Communication Interface. EIA RS-232-C compatible. Full Duplex.

We also offer a range of optional interfacing designed for communications with most of the widely used mainframes and minicomputers.

ORDERING INFORMATION

4014-1 Computer Display Terminal with Standard Data Communications Interface \$14,775
 Option 34, Enhanced Graphics Module (factory installed only) Add \$925

4015-1 Computer Display Terminal with Standard Data Communications Interface \$16,900
 Option 34, Enhanced Graphics Module (factory installed only) Add \$925

OEM terms available on these products.

Tektronix offers maintenance training classes on instruments in the 4010 DVST Graphic Terminal Series. For further training information, contact your local Sales Office or request a copy of the Tektronix Customer Training Catalog on the return card.

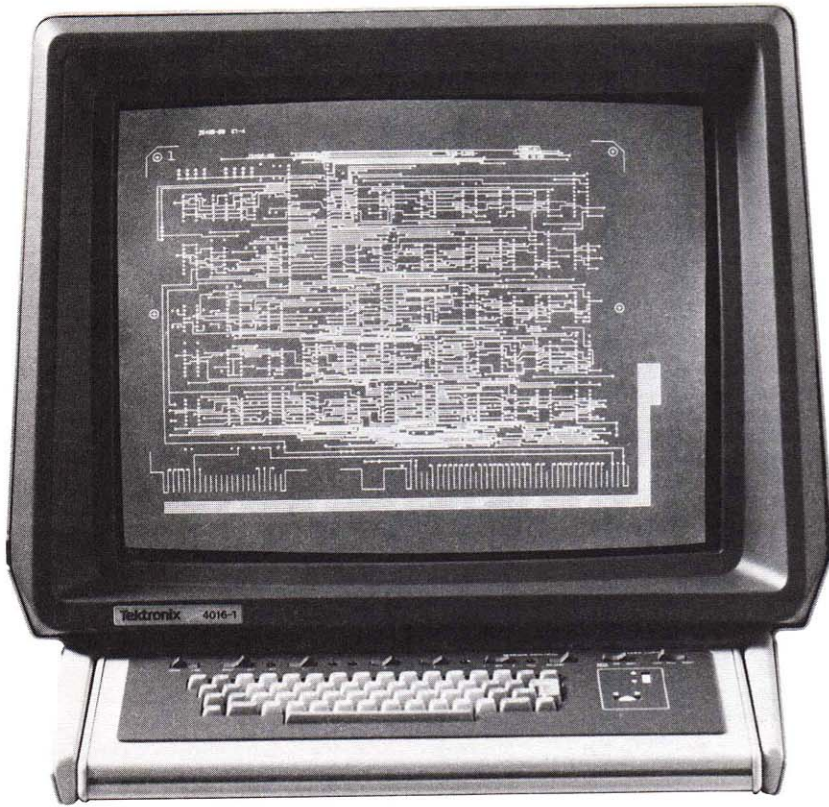

4016-1

636 mm (25 in) Direct-View Storage Display

High-Resolution, Flicker-Free Graphics

Selectable Formats in Graphic and Alphanumeric Modes

Plug-In Intelligence Options

The easiest viewing, most exceptional graphics ever. The 4016-1 was built for designers of electronic circuit boards, utility networks, automotive components, schematic diagrams, street maps or similar applications who need to work with fine detail while maintaining the total picture perspective.

With its big 636 mm (25 in) diagonal screen, 4096 (X) by 3120 (Y) viewable points, and finely etched 10 mil wide vectors, the 4016-1 is uniquely suited for displaying highly complex graphics. Using a Direct View Storage Tube (DVST) display, graphic lines are sharp, stable and flicker-free, simplifying the study of fine details. Thumbwheel-controlled crosshair cursor makes it easy to interactively manipulate the display.

Over 15,000 displayable characters. Besides enabling display of more high density graphic information than any other terminal available, the 4016-1 provides high density alphanumeric for applications, from graphic labeling to newspaper page layout. Over 15,000 characters may be displayed simultaneously and may be formatted as 179 alphanumeric characters per line, like a line printer, or in two 85 character columns, like an open book.

Three other larger character formats are standard with the 4016-1, the largest of which is suitable for group viewing.

Complete TEKTRONIX 4014-1 compatibility. The 4016-1 is compatible with 4014-1 application software, communication support, and other Tektronix peripheral devices. The 4016-1 is supported by the family of PLOT 10 Software products.

Plug-in intelligence. Using the modular 4010 bus structure, add-on low-cost options include up to 26k of usable graphics display memory, scaling, relative graphics, clipping, circular arc generation, rotation by 1° increments, user definable stroke characters, programmable keyboard, GPIB interfacing to the intelligent 4924 Digital Cartridge Tape Drive, 4907 File Manager, and 4662 and 4663 Interactive Digital Plotters, plus the 4953 or 4954 Graphics Tablet.

Commands also allow a user to digitize data with distance, time, or gradient filtering; edit graphics from a host computer, local 4907,4924 storage device or Option 40 programmable keys. Implement off-line plotting by accessing data via local storage devices.

Added enhancements. The 4016-1 includes a convenient detachable keyboard and detachable display.

Other standard enhancements include hardware generated solid, dashed, and dotted lines; point plotting with software controllable point sizes and incremental "relative graphics" plotting.

Hard copy compatibility provides 216 mm x 279 mm (8 1/2 in x 11 in) hard copies from our dependable, dry-process 4631 and 4611 Hard Copy Units.

CHARACTERISTICS

Display Medium — Direct View Bistable storage CRT. Written image bright green on green background.

Display Area — 454 mm x 340 mm (18 in x 13.5 in).

Character Set — Full ASCII character set (94 printing characters).

Standard Character Format

- 1) 74 char/line by 35 lines.
- 2) 81 char/line by 38 lines.
- 3) 133 char/line by 64 lines.
- 4) 179 char/line by 86 lines.

Optional Character Formats

- 1) 74 char/line by 35 lines.
- 2) 81 char/line by 38 lines.
- 3) 121 char/line by 58 lines.
- 4) 133 char/line by 64 lines.

Alphanumeric Cursor — 7 x 9 dot pulsating cursor.

Keyboard — Typewriter paired upper and lower case with auto repeating keys.

Graphics Mode — Vector drawing time is 8000 in/s (20,000 cm/s).

Information Display — 4096 (X) by 4096 (Y) addressable points (12 bits). 4096 (X) by 3120 (Y) viewable points.

Vector Formats — 5 formats, including straight, dotted and dashed lines.

Point Plotting Modes — Point Plot Mode: special Point Plot Mode absolutely addresses points with program control of plotted point size. Incremental Plot Mode relative addressing 1 of 8 directions, one step at a time.

Interactive Graphic Mode — Thumbwheel controlled crosshair cursor. 0 thru 1023 addressable points horizontally. 0 thru 780 addressable points vertically.

Hard Copy Mode — Switch selectable hard copy of screen using the 4611 or 4631 Hard Copy Unit.

ORDERING INFORMATION

4016-1 Computer Display Terminal with Standard Data Communications Interface **\$18,000**

INTERNATIONAL POWER CORD AND PLUG OPTIONS

Option A1 Universal Euro 220 V/16A **No Charge**
Option A2 UK 240 V/13A **No Charge**
Option A3 Australian 240 V/10A **No Charge**
Option A4 North American 240 V/15A **No Charge**

OEM terms available on these products.

Tektronix offers maintenance training classes on instruments in the 4010 DVST Graphic Terminal Series. For further training information, contact your local Sales Office or request a copy of the Tektronix Customer Training Catalog on the return card.



NEW

4027A

Full Color Graphics and Alphanumerics

PLOT 10 Compatible

Fully Supported Color Capability

Dynamic Displays Created Easily

Tektronix makes it practical to add the color dimension. The 4027A offers all the easy data entry, scrolling, and graphics capabilities of the Tektronix high performance 4020 raster-scan family. Most importantly, it provides the kind of fully supported color capability you could expect only from the world's graphics leader.

Full-color graphics, easy to grasp. Colors are selected from a 64-color palette with up to eight colors displayable simultaneously. For specifying lightness, saturation and hue, you'll find the 4027A system as easy as it is versatile.

Local capabilities include colored vectors, characters, symbols, and polygon fill. Firmware enables a second color to border the polygon ... and allows user selection of up to 120 different patterns or color combinations for special applications. Because the capabilities are initiated by firmware, not software, 4027A operation makes minimal demands on host computer communications.

Easy-to-use graphic software. For graphic representation, the 4027A uses color-enhanced PLOT 10 Easy Graphing Software. Easy Graphing simplifies even non-programmer construction of up to six curves or colored bar charts, line graphs with special symbols and dashed lines, legends, titles, and grids.

For more general color graphic applications, Tektronix offers the new PLOT 10 Interactive Graphics Library. IGL is a highly modular package offering all the support commonly required in graphic applications such as 3-D, color panels, line smoothing and many character fonts. PLOT 10 IGL is upward and downward compatible with the full line of Tektronix graphic display terminals.

Graphic input. Graphic input capability consists of a graphic crosshair cursor controlled by graphic cursor keys. In addition to reporting the coordinates back to the host, the terminal also reports the color of the designated coordinate.

Up to 32k bytes of built-in display memory, and up to 192k bytes of graphic memory, allow the same scrolling, dual screen and multiple field formatting featured in other 4020 Series Terminals.

The optional video signal output allows connection of the 4027A to external video displays for group viewing and presentations.

Gray scale representations of 4027A color displays can be made with a TEKTRONIX 4632 or 4612 Video Hard Copy Unit. Detailed, camera-ready color copies of graphs and alphanumeric data can be made on paper or acetate via the TEKTRONIX 4660 Series of Interactive Digital Plotters.

To the standard full duplex, 4027A interface options add half duplex, current loop, polling interface and IBM 3270 compatible polling controller.

All this and alphanumerics, too. In addition to graphic capabilities, the 4027A's extensive alphanumeric capabilities include full ASCII, special and user-definable character sets, and 34 rows of 80 characters.

CHARACTERISTICS

Display Size — 254 mm x 191 mm (10 in x 7.5 in).

Graphics — Standard with full screen crosshair cursor.

Color — 8 colors displayable, colors selected from a palette of 64 colors.

Patterns — 120 user definable color patterns.

Local Functions — Circle and pie generation, polygon fill.

Other 4027A Specifications — Same as 4025A.

Order 4027A Color Graphics Terminal **\$10,000**

OEM terms available on these products.

Tektronix offers maintenance training classes on instruments in the 4020 Raster Scan Terminal Series. For further training information, contact your local Sales Office or request a copy of the Tektronix Customer Training Catalog on the return card.



NEW

4025A

From Alphanumerics To Graphics

ASCII Character Set and Finger Tip Editing

Forms Ruling Option Available

The 4025A creates the perfect marriage of alphanumeric and graphics. You can create and store multiple graphs in memory, create multiple graphs per page, and scroll graphics along with alphanumeric information.

The 4025A gives you the ability to expand a computer terminal from basic alphanumeric, to forms ruling and then to graphics. No other terminal has such versatility up to and including the capacity for unsurpassed report generation.

Start with an ASCII character set and finger-tip editing. In its simplest configuration, the 4025A can display a full 34 lines of 80 characters each on its 279 mm (12 in) diagonal display screen. Complete upper-and lower-case ASCII character set is provided. Green-on-black display with adjustable brightness level keeps even long sessions easy on the eyes.

The 4025A Forms Ruling option can duplicate essentially any form. Visual attributes include enhanced blinking, inverted and underlined fields. Logical attributes include protected fields, modified, alphanumeric or numeric only.

The "send modify" command streamlines data entry by transferring only the modified, keyed-in data to the host. The fixed format remains, ready for the next series of entries. Develop or duplicate forms of any complexity with a variety of single and multiple horizontal and vertical rules selected from the Ruling Character Set. Expandable memory and scrolling let you create forms far beyond the length of the display screen.

To make data entry and editing easier, you can divide the display screen into two separate display areas, each with independent scrolling. You use the monitor area to communicate with the host and the workspace area for the form itself.

The PLOT 10 Easy Graphing Software package lets you interactively create bar charts with multiple shadings, histograms, log plots, pie charts and period axes, all with a wide variety of labeling options.

The keyboard, an office typewriter configuration, is immediately familiar to new users. Pre-defined editing keys simplify insertion, deletion and input of lines and characters. Thirteen user-defineable keys, plus nearly all other keys on the keyboard can be redefined to generate a command or character string at the touch of a finger.

A 16k memory is standard with the 4025A display, expandable to 32k, allowing buffering and scrolling of hundreds and even thousands of words.

Using TEKTRONIX 4631 and 4612 Hard Copy Units you can duplicate on-screen and buffered displays of up to 80 characters by 53 lines. The 216 mm x 279 mm (8 1/2 in x 11 in) copies are clean, dry, and sharp. For detailed, camera-ready copies of graphs and alphanumeric data, choose the TEKTRONIX 4662 Interactive Digital Plotter. The dependable 4642 Printer gives you copies of alphanumeric output only. The 4924 Digital Cartridge Tape Drive provides an inexpensive method of storing forms, graphic formats and other data.

Using the optional 4025A polling controller, you can poll multiple terminals on a single data communications line.

CHARACTERISTICS

Display Size — Video monitor display on 229 mm x 163 mm (9 in x 6.4 in).

Raster Lines — Standard 525 line scan with 480 lines displayed.

Character Set — 64/96 upper and lower case ASCII (optional character sets available).

Alphanumeric — Mode format is 34 lines, 80 characters per line, 2720 characters full screen.

Character — Generation — 7 x 9 in an 8 x 14 dot matrix (graphic cells are 8 x 14 matrix).

Cursor — Wide underscore.

Baud Rate — Selectable to 9600 baud.

Graphics — Optional.

ORDERING INFORMATION

4025A Computer Display Terminal \$5200

INTERNATIONAL POWER CORD AND PLUG OPTIONS

- Option A1 Universal Euro 220 V/16A No Charge
- Option A2 UK 240 V/13A No Charge
- Option A3 Australian 240 V/10A No Charge
- Option A4 North American 240 V/15A No Charge

OEM terms available on these products.

Tektronix offers maintenance training classes on instruments in the 4020 Raster Scan Terminal Series. For further training information, contact your local Sales Office or request a copy of the Tektronix Customer Training Catalog on the return card.



4006-1

Low Cost

Flicker-free High Resolution

Graphic and Alphanumerics

The 4006-1 is one of four solutions towards making interactive, high-resolution graphics affordable to cost-conscious disciplines and departments. Priced no more than many alphanumeric terminals, the 4006-1 makes graphic capability practical for the stock room, the classroom and the conference room as well as for other graphic applications.

The 4006-1 connects readily to most mainframes, thanks to its RS-232-C interface. With a screen capacity of 2590 alphanumeric characters in addition to graphics capability, the 4006-1 can work in configuration with existing alphanumeric terminals to interpret statistics and coordinates into meaningful charts, tables, graphs and diagrams.

CHARACTERISTICS

- Display Medium** — Direct View Bistable Storage CRT.
- Display Area** — 190.5 mm x 142.2 mm (7.5 in x 5.6 in).
- Alphanumeric Mode Format** — 35 lines, 74 character per line, 2590 characters full screen.
- Character Set** — 63 printing characters (TTY ANSI Code).
- Character Generation** — 5 x 7 dot matrix.
- Cursor** — 8 x 8 dot matrix.
- Graphics Display Mode** — Vectors only. Vector drawing time, 3.6 ± 0.2 ms.
- Information Density** — 1024 (X) by 1024 (Y) addressable points. 1024 (X) by 780 (Y) viewable points.
- Baud Rate** — Transmit and receive independently. Selectable from 75 to 4800 baud.

ORDERING INFORMATION

- 4006-1 Computer Display Terminal ... \$3600**
- Option 01, Data Communications Interface Add \$385**



4010-1

Supports Alphanumerics Plus Low-Cost Computer Graphics

Convenient Bus Structure for Peripheral Add-On

Complete PLOT 10 Software Support

Graphic Input

The 4010-1 Computer Display Terminal is an easy to use, cost effective tool that brings out the best of Tektronix' famous graphics capability. Included are flicker-free display, high-resolution graphs, charts, diagrams and renderings produced on a matrix of 1024 (X) by 780 (Y) viewable points and interactive graphics construction via thumbwheel cursor control.

The standard TTY-style keyboard enables easy data entry. Command of both alphanumeric and graphic display is so immediate that hours of hand drafting can become the matter of a few seconds.

CHARACTERISTICS

- Display Medium** — Direct View Bistable Storage CRT.
- Display Area** — 190.5 mm x 142.2 mm (7.5 in x 5.6 in).
- Alphanumeric Mode Format** — 35 lines, 74 characters per line, 2590 characters full screen.
- Character Set** — 63 printing characters (TTY ANSI Code).
- Character Generation** — 5 x 7 dot matrix with MOS Read-Only Memory. 1200 characters per second.
- Cursor** — Pulsating 5 x 7 matrix.
- Graphic Display Mode** — Vectors only. Vector drawing time 2.6 ms.
- Information Density** — 1024 (X) by 1024 (Y) addressable points. 1024 (X) by 780 (Y) viewable points.
- Graphic Input Mode** — Thumbwheel controlled cross-hair cursor. 3 through 1023 (X) 0 through 780 (Y).

ORDERING INFORMATION

- 4010-1 Computer Display Terminal with Standard Data Communication Interface \$5900**

INTERNATIONAL POWER CORD AND PLUG OPTIONS

- Option A1 Universal Euro 220 V/16A No Charge**
- Option A2 UK 240 V/13A No Charge**
- Option A3 Australian 240 V/10A No Charge**
- Option A4 North American 240 V/15A No Charge**

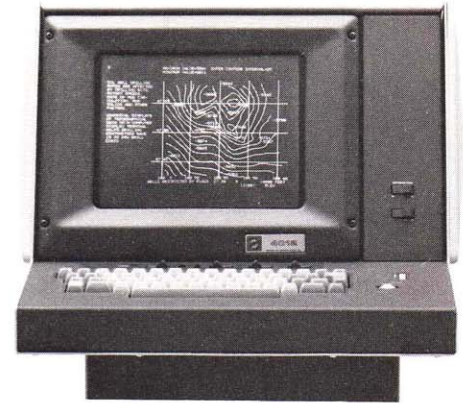

4012

High-Resolution, Flicker-Free Graphics

Full Upper and Lower Case ASCII Character Set

Conventional Bus Structure For Peripheral Add-On

The 4012 combines the world's leading graphics with complete alphanumerics. Alphanumerics can tabulate computer data, but graphics can amplify that data into usable, immediately meaningful information. High-resolution graphic presentations and the full upper and lower-case ASCII alphanumerics are available in the 4012.

The flicker-free screen provides up to 1024 (X) by 780 (Y) viewable graphic points or as many as 2590 A/N characters per display. The TTY-style keyboard simplifies input while the thumbwheel controlled crosshair cursor enhances graphic interactivity. With thumbwheel control, user can direct the X-Y cursor for speedy additions or deletions of data to the display screen.

CHARACTERISTICS

- Display Medium** — Direct View Bistable Storage CRT.
- Display Area** — 203 mm x 152 mm (8 in x 6 in).
- Alphanumeric Mode Format** — 74 characters per line; 35 lines per display; 2590 characters per display.
- Alphanumeric Cursor** — Pulsating 7 x 9 dot matrix.
- Character Set** — 94 printing characters on 7 x 9 dot matrix. (Full ASCII code).
- Character Size** — 85 mils x 105 mils.
- Character Generation** — 7 x 9 dot matrix with MOS Read-only Memory. 1,000 characters per s.
- Graphic Mode** — Vectors only. Vector drawing time 2.6 ms.
- Graphic Matrix** — 1024 (X) by 1024 (Y) addressable points. 1024 (X) by 780 (Y) viewable points.
- Graphics Input Mode** — Thumbwheel controlled cross-hair cursor. 3 through 1023 (X) 0 through 780 (Y).

ORDERING INFORMATION

- 4012 Computer Display Terminal with Standard Data Communication Interface \$7850**

INTERNATIONAL POWER CORD AND PLUG OPTIONS

- Option A1 Universal Euro 220 V/16A No Charge**
- Option A2 UK 240 V/13A No Charge**
- Option A3 Australian 240 V/10A No Charge**
- Option A4 North American 240 V/15A No Charge**

OEM terms available on these products.

Tektronix offers maintenance training classes on instruments in the 4010 DVST Graphic Terminal Series. For further training information, contact your local Sales Office or request a copy of the Tektronix Customer Training Catalog on the return card.

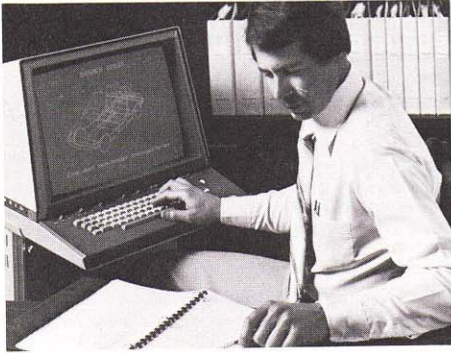

PLOT 10 Graphic Software Library

PLOT 10 is the world's leading commercial graphics library. Versatile, modular, and fully documented, it lets you start with only the code you need to do your job, then expand with modules and utilities to develop more sophisticated or specialized applications. PLOT 10 builds to high-level, "cookbook" solutions such as English-like commands for business applications and other non-programmer environments.

PLOT 10 Includes the following packages:

Terminal Control System (TCS) — A composite of FORTRAN IV subroutines, TCS contains the basic building blocks for all graphic operations. It permits modular as well as system independent programming, and supports such basic graphic functions as windowing, clipping and rotation for DVST terminals and 4660 Series Plotters.

Plotter Utility Routines — These routines link your data base, terminal and TEKTRONIX 4660 Series plotters to enable easy, powerful command of multicolored graphs, charts, maps and renderings. Digitizing is just as versatile by using the built-in joystick.

Advanced Graphing Package — AG II subroutines let a programmer tailor the size, shape and format of graphs, specifying more than 40 graphic elements.

Interactive Graphing Package — IGP simplifies the task of graph storage, editing, recall and updating, so a user with little or no programming experience can create a presentation quality graph, on DVST terminals.

Easy Graphing — A straight forward English language command structure that gives the non-programmer wide-ranging command of graphics in business and engineering decision-making tasks.

Interactive Graphics Library — IGL is a uniquely modular system of I/O, device drivers, primary commands and advanced feature support that lets the user move at will among any Tektronix display devices or technology. Advanced options such as color panel filling, many character fonts, segments and 3-D may be added.

ORDERING INFORMATION

For 4110, 4010 Series Terminals. 4006-1, 4025A and 4027A color display.

Tools for easy use of graphic and alphanumeric capabilities of Tektronix Terminals.

4010A01 PLOT 10 Terminal Control System \$1500

4010A10 PLOT 10 Terminal Control System, Implementation for IBM with TSO \$1750

Versatile software to graph your data using a powerful set of FORTRAN IV subroutines.

4010A02 PLOT 10 Advance Graphing II \$2000

Powerful graphing through English language commands for the non-programmer

4010A03 PLOT 10 Interactive Graphing Package \$2250

Correct your graphics easily with a Tektronix Terminal before plotting.

4010A04 PLOT 10 Preview Routines for Cal Comp Plotters \$500

Provides complete flexibility of character definition, including rotation, scaling, and special characters.

4010A05 PLOT 10 Character Generation System \$225

Point by point TEKTRONIX 4953 and 4954 support, plus pencil and paper input ease for many computer systems.

4010A06 PLOT 10 Graphic Tablet Utility Routines \$200

Office machine simplicity for the production of the most popular formats in graphing.

4010B01 PLOT 10 Easy Graphing Punch Paper Tape \$1380

4010B02 PLOT 10 Easy Graphing 026 Format Punched Cards \$1380

4010B03 PLOT 10 Easy Graphing Magnetic Tape \$1950

4010B04 PLOT 10 Easy Graphing RK-05 Hard Disk \$1480

4010B05 Easy Graphing 029 Format Punch Cards \$1380

Designed for device independent control of DVST, raster scan displays, and plotters. Offers a growing array of graphics control functions such as commands for color, 3-D, line smoothing, and multi font text manipulation. Provides graphic segments support for fast creation and maintenance of picture data bases. Developed in response to proposed ANSI graphics standard.

4010C01 PLOT 10 Interactive Graphics Library \$2500-10,000

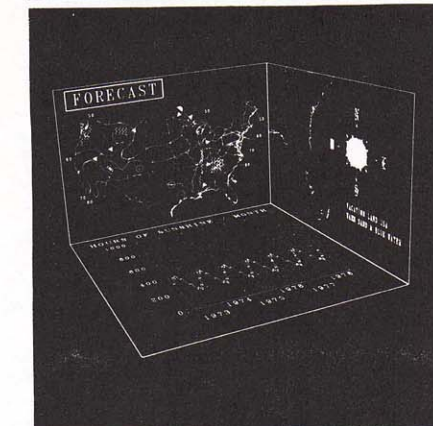
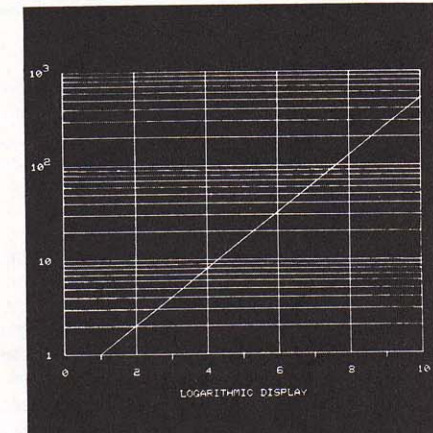
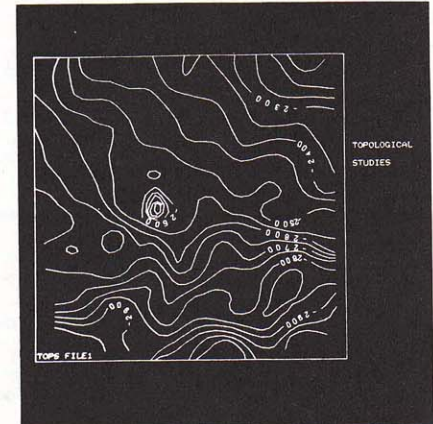
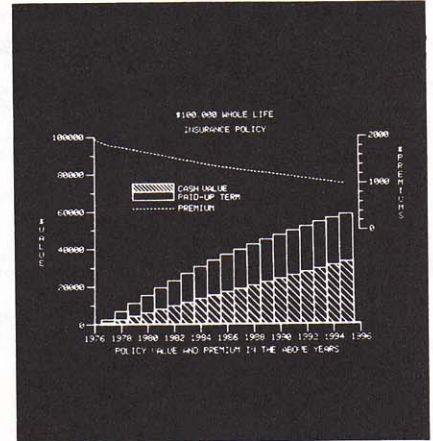



NEW
4041

GPIB
IEEE-488

The 4041 is designed to comply with IEEE Standard 488-1978 and with Tektronix Codes and Formats Standard.

Optimized for Instrumentation Control

Modular Design - Rackmount or Portable

Efficient, Easy to use BASIC Language with Extensions

Expandable Capability Through Memory (to 160 k Bytes) and Other Options

The new 4041 Controller is a powerful, flexible, expandable IEEE-488 systems controller designed to work with Tektronix and other vendor's IEEE-488 instruments. While the basic unit is intended principally for execute only environments such as production line testing, a variety of options and peripherals will equip the 4041 for full interactive flexibility in research lab applications. Tektronix full line of terminals (graphics or alphanumeric, storage or raster, and color) are compatible to create an optimum programmer interface in the more sophisticated areas. Software features similarly span the range from the occasional programmer to the sophisticated programming team tackling complex products. The basic 4041 compactness, permits configuration of very compact systems which can go into applications impractical for earlier generations of systems.

4041 Architecture

The 4041 controller contains three micro-processors, with the CPU being the powerful 16-bit 68000. Standard memory is 32k bytes (approximately 25k user-available), with optional 32k increments to 160k maximum. A 20-character alphanumeric LED display, 20 character thermal printer, DC-100 cassette drive, 18 function keys, an IEEE-488 port, and a RS-232 port are standard. A real time clock and calendar capability are standard on the 4041. Option 01 adds a second pair of ports (one IEEE-488 and one RS-232). The Option 01 IEEE-488 port has Direct Memory Access capability. Other options include an 8-bit parallel TTL port, (Option 02) the program development

ROMs and carrier (Option 30), and a program development/debug keyboard (Option 31). BASIC is an excellent language, and was chosen for the 4041. Its English-like commands, simple syntax, and line-by-line interpreter implementation combine for friendly, easy use. To improve the self-documenting characteristics and thus reduce maintenance costs, 4041 BASIC is enhanced by several features. Variable names may be up to 8 characters, allowing the programmer to select meaningful names like RISETIME, VOLTAGE 1, or DELAY. Subprograms and program lines may be named, with examples such as SRQHNDL or CALCFRMS.

4041 BASIC includes many enhancements such as FORTRAN-like subprograms. Variable passing from main to subprograms and the ability to declare any variables as local or global means that a team of programmers can work quite independently on a massive task, with the main program ultimately being not much more than a series of subprogram CALL statements. Other powerful features include optional data types (short and long floating point plus integer), a COMPRESS command to optimize memory use, a proceed mode which overlaps I/O and processing operations for maximum system speed, logical unit assignment capability, and up to 160k bytes of memory directly addressable without overlays or paging techniques.

Test and Measurement Orientation

The 4041 controller was developed and optimized as an instrument controller. Many of the IEEE-488 functions are simple high level commands in 4041 BASIC. Examples include ATN, GET, LLO, and several others. In its power-up default condition, the 4041 implements Tektronix Codes and Formats standard and thus can communicate instantly with Tektronix IEEE-488 instruments without any programmer attention to formats, syntax, delimiters, number format, etc. However, the 4041 also has virtually complete, programmable control over every IEEE-488 line and condition. When this ability is combined with the 4041's Logical Unit assignment and stream specification ability, virtually any IEEE-488 instrument or device can be easily handled. The stream specification ability means that a particular device's format, syntax, end-of-message character, and other idiosyncrasies can be described one time in a Logical Unit assignment statement. Thereafter, the programmer can control or obtain data from that instrument as easily as from an instrument which fully complies with Tektronix Codes and Formats Standard.

The error trapping and handling capabilities of the 4041 are of particular importance in test and measurement systems. Virtually any category of error — in instruments, peripherals, on the bus, or even within the 4041 — can be trapped and handled by software drivers.

MAGNETIC TAPE DRIVE

File Structure — 48 named files (max).
Capacity (physical records) — 650 typical (600 min).
Physical Record — 256 bytes.
Average Transfer Rate — 13,324 bits per s.
Search Speed — 1520 mm/s 60 in/s.
Tape Rewind — 1520 mm/s 60 in/s.
Tape Cartridge — DC 100 cassette.

PRINTER

Printing Method — Thermal, fixed head.
Capacity — 20-character alphanumeric line.
Font — 5 x 8 dot matrix printed.
Character Size — 2.5 mm high x 1.8 mm wide (.10 in high x .07 in wide).
Line Spacing — 4.23 mm (6 lines per in).
Printing Speed — 1.8 lines/s.
Feed Speed — 8.46 mm per s (.34 in/s).
Character Set — 128 Total
Paper Size — 60 mm x 25 m (2.36 in x 82 ft)

CONTROLLING THE BUS

The 4041 automatically controls all bus management signals in the proper sequence for the desired interface task and instrument interaction.

A bus management function program that uses direct IEEE-488 mnemonic commands accommodates differences in implementation of GPIB on other equipment. Virtually all legal bus states can be programmed this way, which affords a high degree of flexibility for addressing various system applications.

BUS INTERRUPTS

The 4041 has the ability to detect and respond to various types of interrupt conditions that can be generated in the GPIB. User-specified software handlers can be written to perform various tasks when these conditions occur. Interrupts can be programmably ENABLED or DISABLED.

Interrupt conditions are:

| Mnemonic | Message |
|----------|-----------------------|
| SRQ | Service Request |
| EOI | End or Identify |
| IFC | Interface Clear |
| DCL | Device Clear |
| GET | Group Execute Trigger |
| TCT | Take Control |
| MTA | My Talk Address |
| MLA | My Listen Address |

BUS COMMUNICATION

Interface and bus device addressing are programmable. This allows the user to direct message and data flow to and/or from the appropriate interface and GPIB peripheral. Information such as primary and secondary addressing, along with pertinent device-dependent information, can be attached to a specific logical unit number. Subsequent communication with that GPIB device can be directed to the logical unit, eliminating the need for redundant or repetitious statement programming.

TRANSFER RATES (IEEE-488)

Transfer rates for the standard interface are given below.

| Interrupt Mode | Input | Output |
|----------------|---------------|---------------|
| Fast Mode | Exceeds | Exceeds |
| | 5k Bytes/s | 5k Bytes/s |
| Standard Mode | Exceeds | Exceeds |
| | 16.5k Bytes/s | 19.5k Bytes/s |

SERIAL INTERFACE

The 4041 comes with a standard serial asynchronous RS-232C Interface. The 4041 can support applications requiring terminals, modem/host communication, or instrumentation with this interface protocol.

In addition to standard transmission rates from 75 to 9600 baud, transmission rates are programmable to any integer ranging from 2 to 9600 baud.

Full Duplex — Full Capability (half duplex not supported)
Transmit/Receive — Matched rate only
Bits Per Character — 5, 6, 7, or 8 bits
Stop Bits — 1 or 2
Parity — Even, Odd, One, Zero, None

For a complete description and ordering information, refer to pages 292-294.

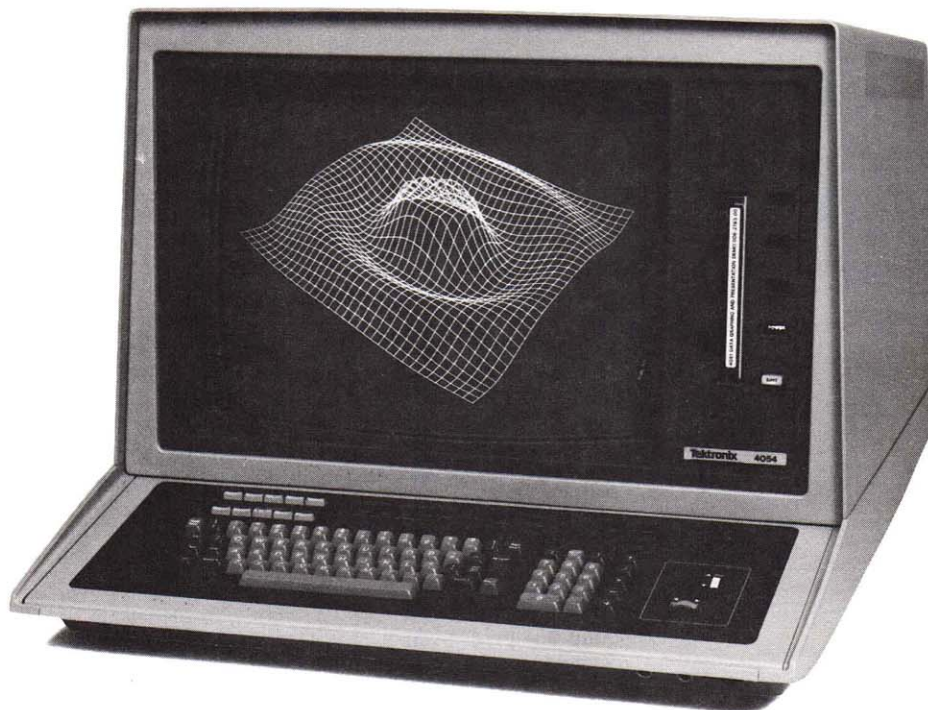

4054



The 4054 is designed to support other products which comply with IEEE Standard 488-1978.

19 In, High Resolution Display

Dynamic Graphics (Option)

Expandable Memory

Enhanced Graphics

Unequaled graphics and powerful, fast computing in an integrated desktop computer. The 4054 is the only desktop computer that combines easy-to-learn, extended BASIC with the unique features of a large-screen, high resolution Tektronix display. For rapid calculation, the 4054 has a fast processor with microcoded floating point. The state-of-the-art graphics capabilities of the 4054 provide demand hard copy on any combination of text and high density graphics (with optional hard copy unit). Fast processing coupled with simultaneous text and graphics display offer an excellent fit for many sophisticated graphics environments. In addition, the 4054's memory capacity can be expanded from a standard 32k bytes, to 64k bytes.

The 4054 has a long list of proven peripheral products. GPIB (General Purpose Interface Bus) and RS-232-C interfacing coupled with easy-to-program BASIC I/O commands allow considerable versatility in designing your own system.

The 4054 features software compatibility with the rest of the 4050 Series of desktop computers. Programs developed on the 4051 and 4052 will

operate on the 4054, giving 4054 users access to a wealth of PLOT 50 Software, already written and debugged, thus reducing program development costs often associated with new systems.

The Dynamic Graphics Option adds increased interactivity to the graphics of the 4054 Desktop Computer.

Dynamic Graphics brings the user closer to the solution by providing the graphic power to work directly with the graphic elements of the design problem. Complicated displays can be constructed quickly and easily with movable user-defined objects.

Superior graphic and alphanumeric display. The 4054 with 4096 (X) and 3125 (Y) resolution — 13 million addressable points — has all the graphics capability you will need for even the most complex display. With stroke-generated characters programmable in four sizes and eight fonts, the 4054 has the tools to alphanumerically dress up your output to suit any professional requirement. The large screen permits previewing of 132 column line printer output.

For your graphing needs there are 36 distinct dot-dash patterns, selectable under program control, providing for maximum effect of represented data. For interaction the 4054 has a thumbwheel driven, true cross hair cursor. All of these features are implemented using the extended BASIC of the 4054.

Friendly extended BASIC provides the simplicity desired for the beginner together with the flexibility and power required by the experienced programmer. Device independent keywords make program and data input/output operations easy either binary or ASCII formats. Fast, built-in BASIC functions such as SINE, LOG, SQR, etc., plus a complete set of matrix functions provide powerful computation at your fingertips.

CHARACTERISTICS

- Processor** — LSI bi-polar 16 bit, same as 4052.
- Keyboard** — Identical to 4052 keyboard but includes added thumbwheels which control crosshair cursor.
- Tape Drive** — Identical to 4052.
- CRT** — Direct view storage CRT.
- Alphanumeric** — Four program selectable formats.
72 characters per line with 35 lines per display.
79 characters per line with 38 lines per display.
119 characters per line with 58 lines per display.
132 characters per line with 64 lines per display.
- Character Set** — Full ASCII, upper/lower case, high quality, stroke generated characters.
- Special fonts** — Selectable under program control—Swedish, German, British, Spanish, Danish/Norwegian, Graphic and Business.
- Graphics** — Vector drawing time - 15k cm/s.
- Addressable resolution** — 4096 (X) by 3125 (Y).
Dot-dashed vectors, programmable in 36 visibly distinct patterns.
Crosshair cursor with built-in thumbwheels for interactivity.
- Visibility** — Flicker-free, easy-on-the-eyes display.
- Copier** — Compatible with TEKTRONIX 4631 and 4611 Hard Copy Units.

ORDERING INFORMATION

- 4054 Desktop Computer** \$20,100
- Option 24 64k Bytes Total Memory** Add \$800
- Option 30 Dynamic Graphics** Add \$3315
- Option 31 Color Enhanced Dynamic Graphics** . Add \$5315

OEM terms available on these products.

Tektronix offers maintenance training classes on the 4050 Graphic System Series. For further training information, contact your local Sales Office or request a copy of the Tektronix Customer Training Catalog on the return card.



4051

GPIB
IEEE-488

The 4051 is designed to support other products which comply with IEEE Standard 488-1978.

Low Cost

High Resolution

Graphics and Alphanumerics

Desktop computing for a whole spectrum of problem solving, data analysis, and decision making applications. The 4051 is a stand-alone computer that is approachable, affordable, and able to grow as your applications grow. From the day you plug it in, the 4051 performs productively by putting solution-oriented BASIC language and meaningful graphic information at your fingertips.

Friendly graphics. Commands like DRAW and ROTATE built into the 4051 give you full graphics flexibility while working in your units, not machine or raster units. Easy graphics accelerates analysis, decision making and model building. It supplements your intuition and gets your point across by making information easy to understand. Once you use graphics you'll wonder how you got along without it.

The GPIB bus is built-in and easy to program with the 4051 BASIC I/O commands. As the industry's choice for connecting instrumentation it is our choice for the 4051 and its many available peripherals.

It includes integrated computing, peripherals, and a GPIB (IEEE Standard 488-1978) interface. You don't have to know how the internal processor works to use it, you simply use the graphically-enhanced BASIC commands.

A 300k bytes magnetic cartridge tape drive is built into the 4051 hardware and language. No bits, no status words to check. File management commands like FIND, OLD, READ, and WRITE, retrieve or store programs and data. A comfortable typewriter keyboard is integrated into the system with a 28-character buffer that eliminates lost entries.

Friendly, extended BASIC provides both power for the sophisticated programmer and simplicity for the beginner. Input and output operations are easy to program and debug because the 4051 commands use device independent keywords. Input and output can be as simple as INPUT or PRINT or can have FORTRAN like power with PRINT, DELETE and IMAGE commands.

A data communication option permits sharing data with a host computer. The asynchronous, RS-232 interface lets you choose terminal mode communications at up to 2400 baud. Terminal modes provide performance like our popular 4012

Computer Display Terminal with local intelligence and direct data transfer between the built-in cartridge tape drive and host computer.

CHARACTERISTICS

Processor — LSI 8 bit microprocessor.

User Memory Workspace — 16k bytes standard, expandable to 32k bytes.

Keyboard — Full 128 ASCII character upper and lowercase with auto repeat 10 key numeric and 5 math function calculator key pad. Line/character editor keys.

User Definable Function Keys — 10 shiftable to 20. Keys for single step execution of programs, auto-numbering, rewinding magnetic tape, or automatic loading and execution of the first program on tape.

Tape Drive — 3M DC 300A cartridge 300k bytes maximum (dependent on number of files).

Rewind Speed — 90 ips.

Search/read Speed — 30 ips.

Structure — 256 bytes with header. File oriented access via BASIC commands

CRT — Direct view storage CRT.

Alphanumeric — 72 characters per line, 35 lines.

Character Set — Full ASCII including upper/lower case. Also includes Scandinavian, German, General European, Spanish, and Special graphic symbol fonts.

Graphic Resolution — 1024 x 780 points.

Visibility — Flicker-free, easy-on-the-eyes display.

Copier — Compatible with TEKTRONIX 4631 AND 4611 Hard Copy Units.

ORDERING INFORMATION

4051 Desktop Computer System \$6295

Option 22 32k bytes total memory Add \$1000



4052

GPIB
IEEE-488

The 4052 is designed to support other products which comply with IEEE Standard 488-1978.

Fast Processing

High Level BASIC

Expandable Memory

High performance computation and communications for a whole spectrum of problem solving, data analysis, and decision making applications. The 4052 is a desktop computer offering high performance, stand-alone computing power, flexible data communications, and easy-to-learn, extended BASIC. These features, combined with high resolution graphics, make the 4052 an excellent choice for scientific and statistical research, forecasting, data acquisition and analysis.

The 4052 is an integrated system offering all the tools necessary to immediately begin providing relevant solutions. For rapid calculation, the 4052 has a fast processor with microcode floating point. The state-of-the-art graphics capabilities of the 4052 provide for demand hard copy of any

combination of text and high-density graphics (with optional hard copy unit). Fast processing coupled with simultaneous display of text and graphics meets the needs of most application requirements.

The 4052 comes standard with 32k bytes of memory, and can be optionally expanded to 64k bytes, allowing larger and more complex programs to be handled. A 300k bytes magnetic cartridge tape drive is built-in, allowing both ASCII and binary programs or data to be easily stored and retrieved using simple file management commands in BASIC. The 4052 keyboard retains the familiar, easy-to-use format of the 4051A typewriter keyboard, yet contains subtle changes made with the user in mind like sculptured keys and non-glare keycaps.

A Family and a System. Our 4051 set the standard for high performance, affordable desktop computing. Following in the 4051's footsteps, the 4052 offers a faster processor and larger memory capacity. The 4054, with a processor similar to the 4052, offers enhanced graphics on a 19 in DVST screen. Combined, they make up the 4050 Series, the only desktop computer line with software compatibility. Programs developed on a 4051 will operate on the 4052 and the 4054 without modification.

The 4050 Series continues to set the standards for high performance, easy-to-use desktop computers. Flexible GPIB and RS-232 interfacing to a wide variety of proven peripheral products allows considerable versatility in designing a system to fit your needs. Additional peripherals can be readily integrated as your application needs grow.

Friendly extended BASIC provides the simplicity desired by the beginner and the flexibility and power required by the experienced programmer. Device independent keywords such as INPUT and PRINT make programming input and output operations easy. Fast matrix functions such as multiply, inverse, transpose, identity and determinants are built into BASIC.

Friendly graphics. Commands like MOVE, DRAW and ROTATE in BASIC allow graphic displays to be created on the 4052 using user defined units, not machine or raster units. Using graphics to display information accelerates analysis, decision making, and model building. It supplements your intuition and gets your point across by making information simple to understand.

CHARACTERISTICS

Processor — LSI bi-polar 16 bit.

User Memory Workspace — 32k standard, expandable to 64k.

Keyboard — Improved, sculptured, matte finish. Keyboard identical in other specifications to 4051 keyboard.

Tape Drive — Identical to 4051 tape drive but provides faster storage and retrieval of programs with direct-to-file operation.

CRT — Direct view storage CRT.

Alphanumeric — 72 characters per line, 35 lines.

Character Set — Full ASCII including upper/lower case.

Special Fonts — Selectible under program control — Swedish, German, British, Spanish, Danish/Norwegian, Graphic, and Business.

Graphic Resolution — 1024 x 780 viewable points, 1024 x 1024 addressable points.

Visibility — Flicker-free, easy-on-the-eyes display.

Copier — Compatible with TEKTRONIX 4631 and 4611 Hard Copy Units.

ORDERING INFORMATION

4052 Desktop Computer System \$9900

Option 24 64k bytes total memory Add \$800

Tektronix offers maintenance training classes on the 4050 Graphic System Series. For further training information, contact your local Sales Office or request a copy of the Tektronix Customer Training Catalog on the return card.

4051R06 Editor ROM Pack (4051 only)

Allows general ASCII file editing of data or programs or text (including FORTRAN, BASIC and COBOL programs) offline. Includes 29 commands such as COPY, INSERT, MOVE, SEARCH and SORT for creating, manipulating and storing ASCII text.

Order 4051R06 \$650

4052R06 Editor ROM Pack (4052 and 4054 only)

Same capability as 4051R06.

Order 4052R06 \$650

4051R07 Signal Processing ROM Pack # 1 (4051 only)

Adds seven new functions which can be applied to one dimensional data arrays; integration, differentiation (2 and 3 point), fast graphing, locating minimum and maximum, and crossing over a threshold. Functions operate 2-10 times faster than equivalent BASIC routines.

Order 4051R07 \$350

4052R07 Signal Processing ROM Pack # 1 (4052 and 4054 only)

Same capability as 4051R07.

Order 4052R07 \$350

4051R08 Signal Processing ROM Pack # 2 (4051 only)

Extends array handling capabilities by adding commands that perform Fast Fourier Transform (FFT), its inverse (IFT), convolution, correlation, windowing and related utility functions. Functions execute 7-20 times faster than BASIC routines.

Order 4051R08 \$700

4052R08 Signal Processing ROM Pack # 2 (4052 and 4054 only)

Same capability as 4051R08.

Order 4052R08 \$700

4052R09 Real Time Clock ROM Pack (4052 and 4054 only)

Provides five time related functions for date and timekeeping, elapsed time measurement and a time programmable 4050 BASIC level interrupt. All functions may be executed directly from the keyboard or may be used within a program.

Order 4052R09 \$500

4052R11 Character and Symbol ROM Pack (4052 or 4054 only)

Generates high resolution stroked characters that can be scaled, rotated and slanted to user's specifications. In addition to the over one-hundred standard characters, users can construct unique custom symbols. The degree of smoothness is selectable for quick screen previews before final plotter copy. Additional commands are provided to extend Dynamic Graphic capabilities.

Order 4052R11 \$900

4051R10 Advanced File Manager ROM Pack (4051 only)

Provides easy access to advanced file management offered by the 4909 Multi-User File Management System. Accessible using commands in BASIC, capabilities such as indexed or "keyed" files, variable length records and dynamic file allocation are supported.

Order 4051R10 \$750

4052R10 Advanced File Manager ROM Pack (4052 and 4054 only)

Same capability as 4051R10.

Order 4052R10 \$750

4050E01 ROM Expander (4051, 4052 and 4054)

Permits connecting up to eight ROM Packs to the 4050 Series Desktop Computer. Utilizes one slot of existing two slot backpack.

Order 4051E01 \$1150

Option 01 Data Communications Interface (4051, 4052 and 4054)

Allows asynchronous bit serial communications between 4050 Series Desktop Computer and any external device conforming to EIA RS-232 standard. Ease of use is facilitated by a special overlay and added language commands that make communication parameters and communications programmable.

Order Option 01 (4052/4054) Add \$1400

Order Option 01 (4051) Add \$900

Option 02 Backpack (4052 and 4054 only)

Optional four-slot backpack.

Order Option 02 Add \$400

Option 03 Backpack (4052 and 4054 only)

Optional four-slot backpack with Option 01 Data Communications Interface built-in.

Order Option 03 Add \$1700

Option 10 Printer Output Interface (4051, 4052 and 4054)

Enables 4050 Series system to output alphanumerics to any printer or output device conforming to the RS-232-C or RS-244A Standard for EIA Numerical Machine Control. Data rates are switch-selectable up to 2400 baud with the 4051, and 9600 baud with the 4052 or 4054.

Order Option 10 Add \$550

Option 30 Dynamic Graphics (4054 only)

Permits complex graphic objects to be created, saved, and recalled with simple BASIC language commands. These objects, saved in a Dynamic Graphics memory can be displayed, blinked, moved anywhere on the screen, and removed without affecting the rest of the display.

Order Option 30 Add \$3315

Option 31 Color Enhanced Dynamic Graphics (4054 only)

Contains Option 30 Dynamic Graphics (see above) with the addition of the latest technology, two color DVST. Refreshed graphics appear in an orange color while stored graphics are displayed in the familiar green. Distinguishability between refreshed and stored graphics are improved with the additional color.

**Order Option 31
(factory option only) Add \$5315**

PLOT 50 Graphics Software Library

PLOT 50 software supports the 4050 Series Desktop Computers. The PLOT 50 software provides flexible, interactive programs that aid the user in scientific, engineering and management applications through easy-to-use high quality graphics.

MATHEMATICS VOLUMES 1 & 2

Volume 1 (23 programs) and Volume 2 (16 programs) consist of routines that provide fast solutions to frequently encountered mathematical problems. Included are function analyses, conversions, integration, differentiation, linear programming, and Fast Fourier Transforms. The math volumes can be purchased separately or together at discount as the Math Library.

STATISTICS

The statistics software includes four tape cartridge-based products (statistics Volumes 1-4) and three disk-based products. These packages represent a well-rounded portfolio of statistics routines, from simple descriptive statistics to multiple linear regressions. The 4050DXX Series of statistics software has been enhanced with a special user interface to make the use of statistics extremely easy in your problem solving.

Functions include small samples analysis, analysis of variance and co-variance, polynomial and multiple linear regressions, and sophisticated non-linear regression techniques. A key feature of the packages is the use of graphics to better understand the nature of the data.

The statistics packages may be purchased separately or at discount as the Statistics Library.

MANAGEMENT GRAPHICS

Business and technical managers are supported by a number of flexible graphing packages. Business Planning and Analysis Volume 1 & 2 provide programs for basic decision making, such as Break-Even Analysis, to Time Series Analysis and Forecasting. Modeling and Reporting Software (MARS) is a general purpose modeling package that allows the user to automate the reporting processes. Data is entered, stored, and manipulated in matrix format. Presentation Aids are oriented towards the easy generation of overhead transparencies, both graphic and textual.

OTHER PLOT 50 PRODUCTS

Picture Composition allows the user to create simple or complex drawings from a tablet without being a programming expert. Graph plot provides the user with multiple graphs per page. General utilities provide subroutines for editing, duplicating, and sorting. Digitizing provides editing and computation support during graphic input. And there's more.

PLOT 50 Software supports the 4050 Series Desktop Computers, providing powerful, interactive programs to aid the user in scientific, engineering, and management application.

Each PLOT 50 volume is driven by menus, prompts and defaults that keep operation fast, friendly, logical and forgiving. You can proceed from master menu to graph, for example, in as few as four keystrokes. You can transfer operation from computer to peripheral in many programs at the stroke of a single key.

Tektronix announces 10 new PLOT 50 Software packages this year:

- 2-D Drafting
- Interactive Digitizing
- Picture Composition
- Micro Pert 2 Project Management
- Document Preparation
- Statistics: Test & Distribution
- Statistics: Analysis of Variance
- Statistics: Multiple Regression
- Statistics: Non-Linear Estimation
- Presentation Aids

At the heart of the library is Tektronix graphics: more kinds of interactive graphics and more meaningful graphics than any competitive software on the market. Access to information is of little value if the keys to understanding and communicating it aren't there, too. PLOT 50 supports the unequalled graphics capability of the 4050 Series.

The displays are not only sharper—thanks to each 4050 Series computer's high-resolution display—they're more complete, too, with features like automatically labeled data points. Or the capability to easily transform the same data into different kinds of graphs.

Most PLOT 50 is compatible with the entire 4050 Series, so you can change computers or exchange data quickly and easily.

Most importantly, PLOT 50 packs tremendous power into the fewest possible keystrokes. Combined with the processing speed of the 4052 or 4054, PLOT 50 Software can perform routines many times faster than competitive packages—and offers many capabilities simply unavailable elsewhere.

PLOT 50 lets you sit down at the computer, load the program, and proceed to the solution. Even complete newcomers to computers can put most volumes to use in less than an hour! With PLOT 50's multiple menus, help files and tutorials, continual prompting and graphic output, even operators unskilled in the application itself can perform many common tasks.

Common Data Exchange Formats

Tektronix has developed common data exchange formats for a number of the PLOT 50 packages to make re-entry of data unnecessary and sharing of data across programs very easy. Standard File Formats (SFF) allow sharing of numeric data across programs and the Graphic Model Exchange (GMX) Format allows sharing of graphic data across program. These common exchange formats represent significant productivity gains for desktop computing graphics users.

Tektronix offers OEM Software Licensing Agreements. See your Tektronix OEM representative for full details.

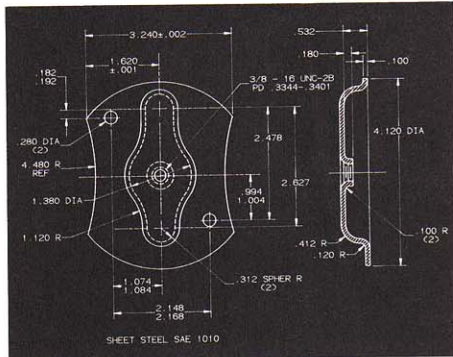

2-D Drafting

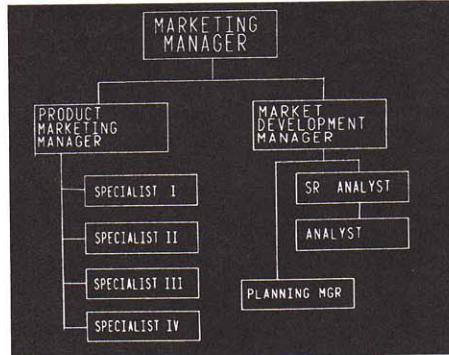

Picture Composition

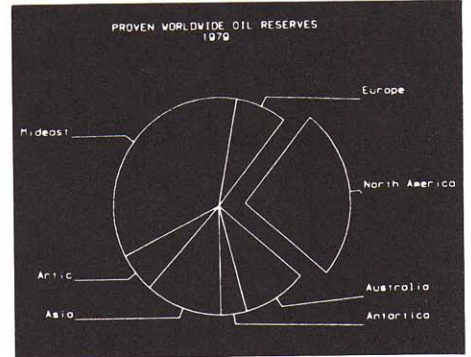

Easy Graphing

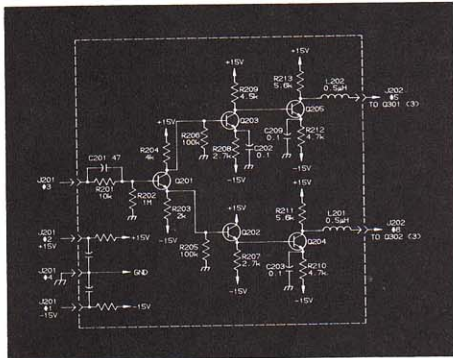

2-D Drafting

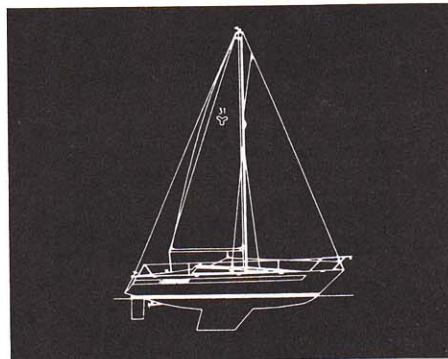

Picture Composition

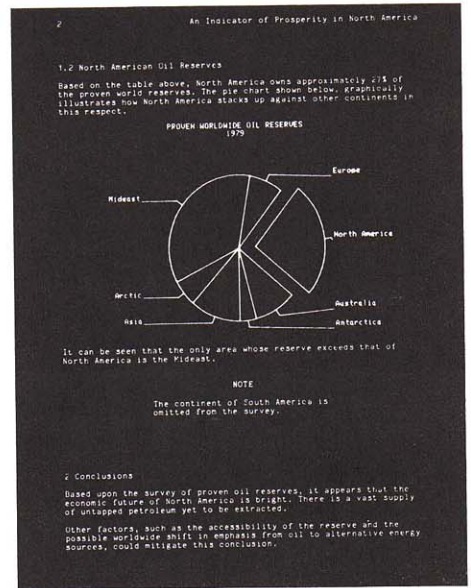

Document Preparation

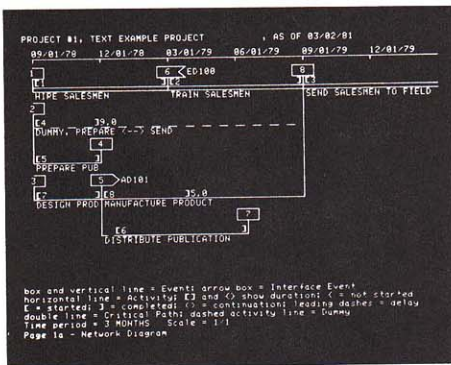

Micro Pert 2 - Project Management

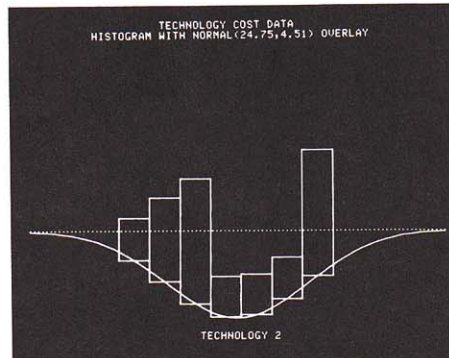

Statistics

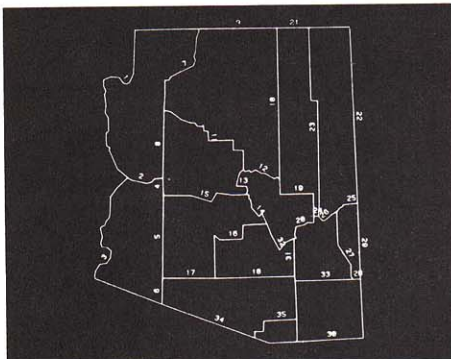

Interactive Digitizing

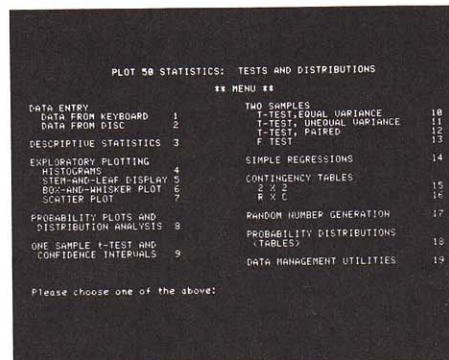

Statistics

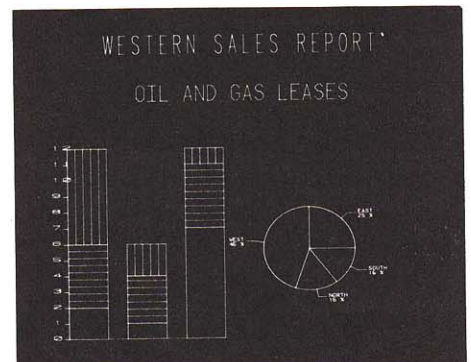

Presentation Aids Vol 1



NEW

4909

Shared Access by a Maximum of 10 Users

Public and Private File Workspaces for Operational Flexibility/File Protection

32 or 96 Megabyte Drive Capacity

Expandable up to 8 drives (768 Megabytes)

Indexed (Keyed) Files Support

Dynamically Allocated Files

Variable Length Records

Concatenated Volumes

High Speed GPIB (IEEE 488-1978) interfacing

English Command Operation Over GPIB

Time of Day Clock with Battery Backup

File Names up to 100 Characters Long

Multiple Level Library Names

The 4909 is a high performance mass storage system based on a controller which provides advanced file management between multiple desktop computers and large capacity hard disk drives.

Flexible file management provides controlled access to files, expandable records and files, and enhanced data storage and retrieval. Plug-in interfacing capability permits host interfacing flexibility and the ability to add more disk drives for expanded capacity.

Mass Storage Expandability

The 4909 offers 32 megabytes of data storage capacity as standard. Optionally, 96 megabytes of storage capacity is available. Each drive comes with a 16 megabyte removable disk cartridge allowing data transportability and fast backup. For increased capacity, additional disk drives can be added by acquiring the 4909AC Auxiliary Cabinet. This cabinet will hold one or two additional disk drives of either 32 or 96 megabyte capacity. Interfacing to the 4909 is by a plug-in disk interface which can support two hard disk drives. A maximum of four disk interface plug-ins can be used on the 4909, supplying a maximum of 768 megabytes of online mass storage capacity.

File Security

Several levels of file security are provided by the 4909. The removable disk cartridge allows large collections of files to be completely removed from the 4909 and placed in a physically secure place. For archival storage, the removable cartridge is highly effective.

Files cannot be affected at the volume level unless a master password is known. If a master password was specified when the original disk volume was formatted, subsequent reformatting cannot take place unless the master password is known, thus prohibiting the modification of existing files.

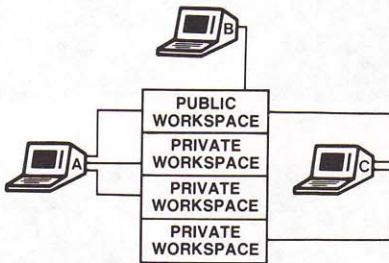

Within a multi-user environment, access to files within a private file workspace is controlled by an access list assigned to each file.

For security, users permitted to use a file within other private file workspaces can be given different levels of access, ranging from read-only to write and delete.

Multi-User Access

The cost effectiveness and contribution to productivity of a mass storage system is enhanced when two or more users are allowed to share information simultaneously. The 4909 allows the sharing and updating of files by up to 10 users. Private file access is permitted after users supply a User-ID and password when accessing the 4909. Access is permitted to a private file workspace if the user entry matches a pre-defined User-ID list maintained by the 4909.

Users who do not provide a User-ID and password when "signing-on" are automatically placed into a public file workspace. All users utilizing the public file workspace have access to the same files, each of which is collectively subject to operations currently taking place by other users within the public file workspace. Public file workspaces allow users of dedicated 4909 systems to not be burdened with multi-user "sign-on" constraints.

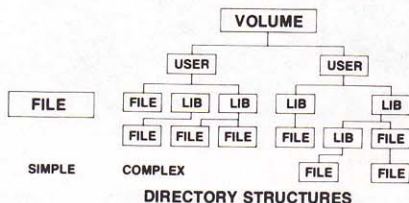

Superior File Management

The 4909 is designed for ease of use and superior file management flexibility. The 4909 lets you manage your files, they don't manage you! File names, for example, can be up to 100 characters long. Multiple levels of files called libraries are provided, allowing files to be grouped according to some particular criteria or need. When files are created, users need not worry about how big a file should be, nor what to do if they write more information than the file can hold. The 4909 provides for dynamic allocation or automatic expansion of files, eliminating this "bookkeeping" task by the user.

Indexed ("Keyed") Files

For users requiring faster, more flexible access to record information stored in files, the 4909 provides indexed files. Each record can be stored and retrieved on the basis of an alphanumeric key. The key used might be an employee's name or a product reference number. With indexed files, information can be organized better, and retrieved faster. A variety of useful commands are provided to allow complete control of indexed files.

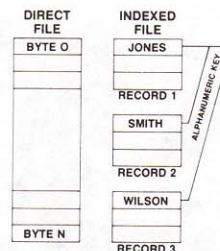

Indexed files don't have to be treated differently from regular files, like on some systems supporting this capability.

True Concatenated Volumes

The 4909 introduces the concept of "concatenated" volume. File size is no longer constrained by the capacity of the drive on which it is located. Multiple drives can logically be configured together to appear as one. Any individual file can assume the size of the total configured drive capacity. Fixed as well as removable disk cartridges can be configured together, or kept separate to allow removable cartridges to be transported between other 4909 hard disk systems. Also, when drives are configured together, users need not be concerned with specifying which of the volumes on which a particular file is stored.

Variable Length Records

Variable length records support by the 4909 provides additional flexibility in creating and updating files, allowing records to change in accordance with user requirements.

Interfacing Flexibility

The 4909 controller has eleven plug-in slots allowing a variety of special purpose interfaces to be supported. In addition to hard disk interfacing, access to desktop computers is provided using a GPIB (IEEE 488-1978) plug-in interface. Assuming the 4909 controller contained only a single disk interface, up to ten GPIB interfaces could be supported. A maximum data transfer rate of 240,000 bytes/second is possible per GPIB interface, with some performance degradation depending on the number of users, and the amount of disk access taking place.

ROM Pack Operation

Access to the 4909 from the 4050 Series of desktop computers will be via GPIB interfacing used in conjunction with a ROM pack to provide file management operation. ROM packs for the 4050 Series include the 4051R10 for use with the 4051, and the 4052R10 for use with the 4052/4054.

English Command Operation

Without a ROM pack, devices supporting any IEEE 488-1978 Standard Compatible interface can communicate directly with the 4909, using English commands. The 4909 will respond to ASCII command strings sent over the bus, and can therefore be used by a variety of non-Tektronix desktop computers or controllers.

Real Time System Clock

The 4909's real time clock, once set, automatically assigns the time and date to a file, allowing users to keep track of when files were created or updated. Files can be manipulated on the basis of their time/date "stamps," e.g. a user may want to delete all files that have not been accessed since a particular date.

ORDERING INFORMATION

| | |
|--|-----------------|
| 4909 Multi User File System | \$22,000 |
| Option 33 96 Megabytes Disk | Add \$4000 |
| 4909AC Auxiliary Cabinet | \$13,000 |
| Option 33 96 Megabytes Disk | Add \$4000 |

FIELD INSTALLABLE OPTIONS

| | |
|------------------------------------|--------|
| 4909F01 GPIB Interface | \$1600 |
| 4909F03 Disk Interface | \$1600 |
| 4909F10 Controller Expansion | \$1000 |

ROM PACK OPTIONS

| | |
|------------------------|-------|
| 4051R10 ROM Pack | \$750 |
| 4052R10 ROM Pack | \$750 |

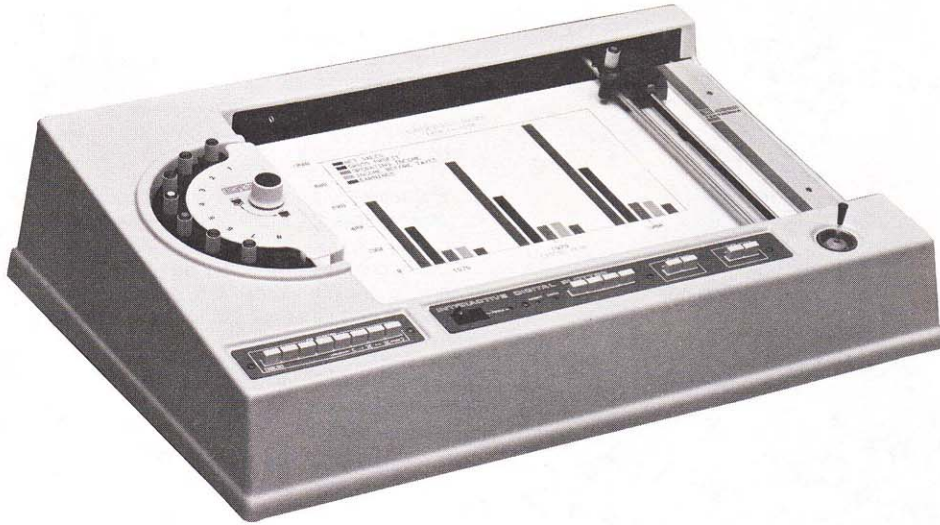

NEW

4662 Option 31

Intelligent B-Size (A3) Plotter

8-pen Turret Version

Compatible in RS-232C ASCII Environments

Supported by PLOT 10 and PLOT 50 Software

The 4662 Option 31 adds the convenience of an automatic 8-pen turret to the built-in processing and feature-packed performance of the world's most versatile small plotter.

Tektronix has always offered its plotter customers the largest selection of colors, pen types and line widths. With the Option 31 turret, you can insert any eight pens and program the 4662 to make the selection for you. Mix and match hard-nib, fiber-tip and wet-ink pens. Include fine line widths for the most precise plots, or for drawing several plots on a single page. Work with nine available colors in adding greater clarity and appeal to presentations and camera-ready plots.

You can retrofit your present 4662 with the Option 31 turret. It can be installed quickly and reliably by any Tektronix service engineer. Updating existing programs to include programmed pen selection requires the addition of just a few lines of code.

That's all part of the Tektronix design philosophy of product upgradability (we also provide 4662 owners with a field-installable 8k memory enhancement). That's why Tektronix has a worldwide reputation not only for product reliability, but for the reliability of its products as long-term investments.

From the moment you turn it on, you can see that it is convenient, cooperative, and more than competent. It automatically adjusts for a maximum 254 mm x 381 mm (10 in x 15 in) plot. To set a different plotting area or to adjust to a new paper size, you simply use the SET control buttons on the front panel to define the new area.

And once it starts moving, you can see it drawing on its microprocessor intelligence to draw curves that are really curve forms. To maintain superior accuracy and repeatability, even at speeds as high as 559 mm/s (22 ips). To select and seat each pen perfectly, whichever pen style it picks up next.

Because input data is internally buffered, you can optimize data transfer from the host processor, or move on to your next computation while the 4662 is plotting.

The 4662 Option 31 is equipped with both RS-232C and GPIB interfaces as standard.

Digitizing on any compatible Desktop Computer or host system is easy with the 4662's built-in joystick control. Move the pen to the desired position on the plot, press the CALL key, and the plotter sends the X-Y data points to the system. A GIN command causes the plotter to send the current XY pen coordinates and pen up, pen down information.

The 4662's internal alphanumeric character generator produces a full upper-lower case ASCII character set. You can request alphanumerics of any height and width, and rotate them as fine as 1° increments.

Selected characters are available in seven different standard fonts. You can plot on paper, on Mylar, or on acetate for overhead transparencies of the highest quality.

Plotter utility routines in the PLOT 10 Graphics Software Library are comprehensive and proven in thousands of sites around the world. In the PLOT 50 Library, for use with Tektronix Desktop Computers, are powerful new menu-based Picture Composition and Easy Graphing packages that take you from first idea to final plot in the fewest possible keystrokes—just as the Option 31 turret gets you there with the fewest possible delays.

OEM terms available on these products.

CHARACTERISTICS

Plotting Area — X-Axis >381 mm (15 in). Y-Axis >254 mm (10 in).

Repeatability — ±0.063 mm (±0.0025 in) same pen. ±0.25 mm (±0.010 in) pen exchanged.

Time to Maximum Velocity — ≈120 ms.

Data Resolution — 0.127 mm (0.005 in).

Plotting Rate — User programmable from 10 mm/s to 570 mm/s in 10 mm/s increments.

Point Plotting Rate — Pen action rate 10 points/s max.

Pen Control — Each pen may be selected either under software control or by operating buttons on the Pen Control Module.

Position Controls — Joystick vector rates variable from .038 mm/s to 102 mm/s (0.015 ips to 4 ips).

Writing Method — Fiber-tip hard-nib or wet-ink pens.

Paper Size — 279 mm x 431 mm (11 in x 17 in max).

Paper Retainer — Electrostatic holddown.

Front Panel Controls —

- POWER switch
- POWER indicator
- PROMPT indicator
- ERROR indicator
- LOAD switch

Disengages electrostatic holddown moves pen to upper right corner of plotting surface.

LOCAL switch

For data communication between terminal and plotter with the RS-232C interface.

PEN switch

Provides manual control of pen up-down motion.

CALL switch

Used to store coordinate points during digitizing operations.

SET controls

Two switches—SET LOWER LEFT and SET UPPER RIGHT—used for convenient page scaling and aspect ratio changes if desired. May be used to allow plotting mirror images.

JOYSTICK positioning control.

LOCATE controls

Two switches LOCATE LOWERLEFT and LOCATE UPPER-RIGHT position pen in respective corner of the currently defined page.

Pen Control Module — 1-8 switches. Exchange active pen in location corresponding to numbered switch depressed.

The following functions are activated by holding the switch in the down position until the bell rings.

STORE PEN switch causes the active pen to be stored in the turret.

[1-4] Opens turret to the 1-4 position for loading pens.

[5-8] Opens turret to the 5-8 position for loading pens.

[RETURN] Returns turret to the closed position

[FAST] Switch directs plotter to plot at full speed.

[SLOW] Switch directs plotter to plot at half speed.

[PAUSE] Causes the plotting motion to stop in the middle of a plot.

[RESUME] Causes the plotting motion to begin after a pause has been enabled, without any loss of data.

Rear Panel Controls — Four rotary hexadecimal switches to control various interface parameters.

RS-2320C interface Asynchronous full duplex data transmission at 110, 150, 300, 600 or 1200 baud. All data transmitted in ASCII.

Operating Modes — The 4662 Option 31 has 2 input modes in RS-232C. Alphanumeric (Alpha) and Graphic plot (Graphic) The 4662 Option 31 also has Graphic input (GIN) to the host.

Character Set — The alphanumerics feature includes 95 ASCII printing characters plus BELL, RS, CRT, FF, HT, LF, and VT characters, all under full program control. The alphanumeric feature may be changed to suit the individual needs by modifying Alpha Scale which allows changing character size. Alpha Scale which allows changing character size. Alpha Rotate which rotates the printing plane and Alpha Font which allows selection of 7 sets of special character fonts.

Input Power — 90 W max 60 W typical. Selection of 105 V ±14%, 116 V ±14% 210 V ±14%; 232 V ±14%. Line frequency 48 to 66 Hz.

PHYSICAL CHARACTERISTICS

| Dimensions | PHYSICAL CHARACTERISTICS | |
|------------|--------------------------|-------|
| | mm | in |
| Width | 654 | 25.75 |
| Height | 203 | 8.00 |
| Depth | 495 | 19.50 |
| Weight | kg lb | |
| | 16 | 35 |
| Shipping | 21 | 46 |

ORDERING INFORMATION

4662 Interactive Digital Plotter

Option 31 \$5300

Span Field Retrofit Kit

for standard 4662 (021-0339-00) \$1500



4662

Intelligent B-size (A3) Plotter

Multi-color Capability

Built-In RS-232 and GPIB Interface

The 4662 is the first plotter with built-in processing power. As such it has the capability to work on its own, without bogging down computational operations. Studded with state-of-the-art technology, it works with an accuracy and repeatability that no other plotter can approach for the price.

From the moment you turn it on, you can tell the difference: the 4662 automatically adjusts for 254 mm x 391 mm (10 in x 15 in) plot. There's no need to worry how the last plot was set up. When you wish to set a different plotting area or adjust to a new paper size, you simply use the SET control buttons on the front panel to define the new area. The 4662 plots on paper, vellum, mylar, acetate-film and preprinted forms.

Once it starts moving, you really notice the improvement over other plotters: the 4662's digital stepping motors and internal vector generator work at high speed, with microprocessor-controlled acceleration and deceleration.

Repeatability is excellent, time after time. There is no servo hysteresis, no drift as in potentiometric feedback systems. And no slidewires to clean, no moving electrical contacts, no servo adjustments to be made.

It's a better kind of plotter with a competitive price for which Tektronix is famous.

The complete plotter. The 4662 is not only easy to talk to; it has a great memory. Input data is internally buffered so you can optimize data transfer from your host processor, or move on to your next computation while the 4662 is plotting.

Up to four 4662's can be teamed up in series, and up to 15 4662's can be used with one GPIB device like the TEKTRONIX 4050 Series of desktop graphic computers. Each plotter can perform its own job simultaneously while the host processor turns to other tasks. A simple, unique code activates each plotter.

Digitizing on any compatible graphic terminal or host system is easy with the 4662's built-in joystick control. Move the pen to the desired position on the plot, press the CALL key, and the plotter sends the X-Y data points to the system. A GIN command causes the plotter to send the current X-Y pen coordinates and pen up, pen down information. If the pen is outside the page boundaries, boundary values are sent and a bell on the plotter signals the operator.

The 4662's internal alphanumeric character generator produces a full upper-lower case ASCII character set. You can request alpha-numeric of any height and width. Selected characters are available in seven different standard fonts. In addition, interchangeable pens and pen types offer multicolor and multiline width capability.

Plot from any point of view. Not only is character scaling possible, but alphanumerics can just as rapidly be rotated in 1° or finer increments. Drawing speed is generally as fast or faster than any other plotter in the 4662's price range. Both RS-232 and GPIB interfaces are standard at no extra cost.

Contact your local Tektronix Sales Engineer for more information on this easy-to-use, exceptional B-size plotter.

CHARACTERISTICS

- Plotting Area** — X-Axis >381 mm (15 in).
Y-Axis >254 mm (10 in).
- Repeatability** — ±0.06 mm (±0.0025 in).
- Time to Maximum Velocity** — ≈120 mm/s.
- Resolution** — 0.127 mm (0.005 in).
- Plotting Rate** — 40.6-55.9 mm/s (16-22 ips) vector dependent.
- Point Plotting Rate** — Pen action rate 10 points/s max.
- Character Set** — Full ASCII character set.
- Pen Control** — By software control or by operation of front panel PEN button. Pen may be disabled manually.
- Position Controls** — Joystick vector rates variable from 0.015 ips to 4 ips.
- Writing Method** — Fiber-tipped pen or wet ink drafting pen.
- Paper Size** — 279 mm x 432 mm (11 x 17 in) max.
- Paper Retainer** — Electrostatic hold-down.
- Drive Characteristics** — Two four-phase stepping motors, each operating a pulley/cable system to propel the pen in that motor's respective axis.

ORDERING INFORMATION

4662 Interactive Digital Plotter \$4600

- Option 01 GPIB I/F cable instead of RS-232C I/F cable No Charge
- Option 20 8k Buffer Add \$495
- Option 31 8 pen turret Add \$700
- 4662A01 PLOT 10 Utility routines software Add \$420

INTERNATIONAL POWER CORD AND PLUG OPTIONS

- Option A1 Universal Euro 220 V/16A No Charge
- Option A2 UK 240 V/13A No Charge
- Option A3 Australian 240 V/10A No Charge
- Option A4 North American 240 V/15A No Charge

OEM terms available on these products.



4663



The 4663 is designed to support other products which comply with IEEE Standard 488-1978.

Intelligent C-Size (A2) Plotter

Dual Programmable Pen Control

Nine Character Fonts

RS-232 and GPIB Product

Finally: an intelligent plotter that saves time without sacrificing flexibility. The 4663 is the first high speed C-size plotter with built-in processing power and 5.5k buffer memory to free the host from many routine computational operations. But the 4663 story isn't just the intelligence, but how intelligently it has been put to use.

The 4663 can handle either 420 mm x 594 mm (European A-2 drafting size) or 432 mm x 559 mm (American C size — 17 in x 22 in) paper, mylar or acetate with felt tip, hard-nib, or wet ink pens to give you crisp, clean camera-ready copies or overhead transparencies.

A paper advance option is available for roll stock, with form feed remotely or locally programmable. This option allows the 4663 to operate unattended with a variety of form sizes.

The plotter features dual programmable pen control with interchangeable multicolor pens and is capable of producing dotted or dashed lines from local firmware. Built-in joystick allows easy manual positioning of the pens for digitizing or page scaling adjustments.

Features like these make the 4663 a natural for printed circuit board manufacturing and metal working applications or civil engineering and drafting environments including CalComp pre-viewing and mapping.

Unique parameter entry device. This front panel card device lets you quickly identify or select operating parameters without resorting to binary switches, straps, status display devices, and volumes of operator manuals. It allows you to quickly program baud rate, pen type, acceleration, plotting speed, aspect ratio, page size and many other parameters.

These parameters can be stored up to 90 days without power. Up to four users can configure the plotter to their individual requirements with Option 37.

Excellent penmanship. Nine character fonts come standard with the 4663, including the full ASCII character set. All characters can be scaled, slanted, rotated and may be centered when used as plot symbols.

Several other performance options are offered such as downloadable character sets, and programmable macros. Arc and circle generation capability, utilizing circular interpolation, is also available. Standard fixed macros allow the current viewport to be outlined or an axis drawn.

Local functions. Various graphic functions are implemented via firmware. Page scaling, windowing, viewporting and clipping are typical.

Hardware loop through RS-232C interface is standard and optional GPIB is available.

Graphing software support. Tektronix PLOT 10 Utility Routines for the 4663 control the plotter's multiple pens, paper advance, and built-in arc and circle generation. They also control selection of built-in character fonts. The 4663 is also compatible via GPIB with the 4050 Series of desktop computers using BASIC language keywords to provide similar controls.

CHARACTERISTICS

Max Plotting Area — X-axis 569 mm (22.4 in). Y-axis 432 mm (17 in).

Repeatability — ± 0.025 mm (± 0.001).

Max Plotting Speed — 406-559 mm (16-22 ips) Vector dependent.

Point Plotting Rate — 10 pts per s max.

Character Generator — 95 ASCII, 15 x 7 Matrix, 7 Special Fonts Std.

Paper Size — European A2 size 420 mm x 594 mm, U.S. C-Size 17 in x 22 in.

Paper Retention — Electrostatic hold down, sprocket feed paper advance (Optional).

Media Types — Paper or Mylar.

Drive Characteristics — Microprocessor controlled stepping motors controlling cable system connected to pen arm.

Baud Rate — 110-9600 baud.

Standard interface — RS-232-C, full duplex, loop-through.

ORDERING INFORMATION

4663 Interactive Digital Plotter \$10,900

Option 01 GPIB I/F cable Add \$525

Option 04 GPIB only (deletes RS-232C) No charge

Option 31 circular interpolation and programmable macros Add \$525

Option 32 Math character set and downloadable characters Add \$450

Option 36 Paper advance Add \$990

Option 37 Added default parameters Add \$325

INTERNATIONAL POWER CORD AND PLUG OPTIONS

Option A1 Universal Euro 220 V/16A No Charge

Option A2 UK 240 V/13A No Charge

Option A3 Australian 240 V/10A No Charge

Option A4 North American 240 V/15A No Charge

4663A01 PLOT 10 Utility Routines

Software \$665

OEM terms available on these products.

Tektronix offers maintenance training classes on the 4663 Interactive Digital Plotter. For further training information, contact your local Sales Office or request a copy of the Tektronix Customer Training Catalog on the return card.

Hard Copy Devices

Quick and convenient copies of complex information displayed on a screen are essential to the use of graphic terminals, desktop computing systems, and video image processing systems. Graphic and alphanumeric information is recorded on paper at the press of a button, to fulfill a variety of user needs. These include the need for quick preview copy before final plotting, and copies of intermediate steps during interactive work sessions. Just as important are permanent records of results for the file, and final output of high quality for use in reports and presentations. Tektronix offers six display copying devices to cover all of these hard copy needs.

Within the product family are two devices for copying storage tube screens, and four for copying general video devices such as raster scan terminals, video cameras and monitors, or image processing systems. Tektronix' own implementation of fiber optic technology is provided in the 4631 for storage tube copy, and in the 4632, 4633A and 4634 for video imaging copy and line scanning recording copy. An innovative Tektronix implementation of electrostatic technology is offered in the 4611 for storage tube copy, and the 4612 for video copy.

Fiber optics, based on photosensitive (light exposure) techniques, gives the highest quality hard copy for dense and complex graphic displays.

Electrostatic technology, based on charge transfer techniques, provides the highest contrast black-and-white images with high quality at an economical cost per copy.

The concept of these alternative family offerings is to fulfill a variety of hard copy requirements — whether the need is for low-cost black and white terminal copy, or for high resolution gray shaded copy from a sophisticated image processing system.



NEW

4611

Low Copy Cost

High Contrast, Permanent Images

Electrostatic Process

Storage Tube Compatible

The 4611 provides permanent, dry copies of graphic and alphanumeric information displayed on storage tube screens. The 4611 is based on electrostatic (charge transfer) technology, and uses electrographic paper for high contrast, archivable copies at an economical copy cost.

The 4611 uses a unique dry toning process that is convenient, non-messy and superior to liquid toner systems. Images are permanently fused and made from inert, safe ingredients.

Compact and lightweight, the 4611 can easily be moved from desk to desk. A warm-up light and paper-out indicator are provided. All copies are vertically oriented, and the copy time is 24 seconds.

The 4611 can be multiplexed to copy up to four storage tube terminals and/or display monitors. It is compatible with the 4010 Series of computer display terminals, the 4114 terminal, the 4025 terminal, the 4050 Series of graphic computing systems, and the 4081 interactive graphics terminal. The 4611 is also compatible with Tektronix 11 in and 19 in computer display modules.

CHARACTERISTICS

- Weight** — 45 lb.
- Paper Size** — 216 mm x 277 mm (8.5 in x 11 in).
- Image Size** — 7.5 in x 5.7 in standard
7.5 in x 8.9 in when copying 4025 terminal.
- Copy Time** — 24 s (30 s when copying 4025 terminal).
- Warmup Time** — 2 min.
- Addressability** — 256 dots per in, horizontal 171 dots per in, vertical.
- Toner** — Dry magnetic 4.9 oz. per bottle.
- Paper** — Electrographic (dielectric) 500 ft per roll.

ORDERING INFORMATION

- 4611 Hard Copy Unit** \$4400
- Option 02 Four — Channel Multiplexer** \$500
- Option 31 Compatible with the 4025 Terminal ..** No Charge
- Paper — One case of two rolls, 006-2838-00** \$24
- Toner — One bottle, 006-2990-00** \$20

INTERNATIONAL POWER CORD AND PLUG OPTIONS

- Option A1 Universal Euro 220 V/16A** No Charge
- Option A2 UK 240 V/13A** No Charge
- Option A3 Australian 240 V/10A** No Charge
- Option A4 North American 240 V/15A** NO Charge

Tektronix offers maintenance training classes on Hard Copy Units and the terminals they support. For further training information, contact your local Sales Office or request a copy of the Customer Training Catalog on the return card.



NEW

4612

Low Copy Cost

High Contrast, Black and White Images

Electrostatic Process

Video Source Compatible

The 4612 provides permanent black-and-white copies of graphic and alphanumeric information from raster scan terminals and other video signal sources. Based on electrostatic technology, the 4612 uses electrographic paper for high contrast, archival copies at an economical copy cost. The 4612 uses a unique dry toning process that is convenient, non-messy and superior to liquid toner systems. Images are permanently fused and made from inert, safe ingredients.

Compact and lightweight, the 4612 can easily be moved from desk to desk. A warm-up light and paper-out indicator are provided. A special self-test switch allows the operator to verify that the unit is operating correctly. All copies are vertically oriented, and the copy time is 24 seconds. The 4612 can be multiplexed to copy up to four raster scan terminals, and can accept remote copy signals. The 4612 is compatible with the TEKTRONIX 4112 Option 11 terminal, and with a wide variety of raster scan terminals and video signal sources; including those which produce RS-170, RS-330 or RS-375A type signals.

The standard unit is prepared for use with 525 line, 60 Hz sources. Adjustment for 625 line, 50 Hz is provided as an option. In some cases, internal adjustments can also be made to accommodate non-standard video sources.

CHARACTERISTICS

Weight — 45 lb.

Paper Size — 216 mm x 277 mm (8.5 in x 11 in).

Image Size — 7.5 in x 5.8 in standard when copying 525 line, 60 Hz signals.

Copy Time — 24 s.

Warmup Time — 2 min.

Addressability — 256 dots per in, horizontal; 171 dots per in, vertical.

Toner — Dry magnetic 4.9 oz. per bottle.

Paper — Electrographic (dielectric), 500 ft per roll.

ORDERING INFORMATION

| | |
|---|------------------|
| 4612 Hard Copy Unit | \$4400 |
| Option 02 Four-Channel Multiplexer | Add \$500 |
| Option 03 Setup for 625/50 Scanning Standard | No charge |
| Option 15 Video Input Via 15 Pin Connector | No charge |

INTERNATIONAL POWER CORD AND PLUG OPTIONS

| | |
|---|------------------|
| Option A1 Universal Euro 220 V/16A | No Charge |
| Option A2 UK 240 V/13A | No Charge |
| Option A3 Australian 240 V/10A | No Charge |
| Option A4 North American 240 V/15A | No Charge |

| | |
|---|-------------|
| Paper — One case of two rolls, 006-2838-00 | \$24 |
| Toner — One bottle, 006-2990-00 | \$20 |

OEM terms available on these products.



4631 Hard Copy Unit

High Image Quality

Copies in Seconds

Fiber Optic Process

Storage Tube Compatible

The 4631 provides permanent, dry copies of any graphic and alphanumeric information displayed on the storage tube screen. The 4631's fiber optic process uses dry silver paper for the fine detail and photographic quality image needed when copying complex graphics and alphanumerics. The 4631 requires no toners or chemical additives of any kind. The entire process is clean and safe, as images are created using only light and heat.

The 4631 is easy to move wherever needed. As a special convenience, the 4631 automatically cuts and stacks all copies into its built-in tray. A four-digit copy counter is an optional feature.

Copies can be made in either vertical or horizontal format. The copy time is 18 seconds for the first copy and only 10 seconds for subsequent copies of the same display. A special "slow scanning" mode allows images on the horizontal format to be made at even higher resolution and image quality.

The 4631 can be multiplexed to copy up to four storage tube terminals and/or display monitors. It is compatible with the 4010 Series of computer display terminals, the 4114 terminal, the 4025 terminal, the 4050 Series of graphic computing systems, and the 4081 interactive graphics terminal. The 4631 is also compatible with Tektronix 11 in and 19 in computer display modules.

4632 Video Hard Copy Unit

High Image Quality

Gray Scale Capability

Copies in Seconds

Video Source Compatible

The 4632 provides permanent copies of graphic and alphanumeric information from raster scan terminals and other video signal sources. All copies are horizontally oriented. The copy time is 18 seconds for the first copy, and only 8 seconds for subsequent copies of the same display. Eight distinct shades of gray can be copied with a special gray scale enhancement option. The standard 4632 can clearly show six different shades of gray, for polygon fill-in, bar charts, and many other applications.

The 4632 can be multiplexed to copy up to four raster scan terminals, and can accept remote copy signals. The 4632 is compatible with the TEKTRONIX 4112 Terminal and with a wide variety of raster scan terminals and video signal sources, including those which produce RS-170, RS-330, RS-375A, RS-343A and RS-412A type signals. The standard 4632 is prepared for use with 525 line, 60 Hz sources. Many other adjustments are provided as options, including adjustments for 625 line, 50 Hz and for high resolution 1029 line, 60 Hz.

COMMON CHARACTERISTICS

Weight — 65 lb.

Paper Size — 216 mm x 277 mm (8.5 in x 11 in).

Warmup Time — 10 min.

Addressability — 20 dots per in, horizontal.
171 dots per in, vertical.

Paper — Standard Dry-Silver, 500 ft per roll.

4631 CHARACTERISTICS

Image Size — 225 mm x 170 mm (8.85 in x 6.7 in), horizontal format.
180 mm x 137 mm (7.1 in x 5.4 in), vertical format.

Copy Time — 18 s first copy (36 s in special scan mode).
8 s subsequent copies (17 s in special scan mode).

High Resolution (Special Scan Mode) — 340 dots per in, horizontal. 300 dots per in, vertical.

4632 CHARACTERISTICS

Image Size — 213 mm X 160 mm (8.4 in X 6.3 in).

Copy Time — 18 s first copy, 8 s subsequent copies.

Gray Shades — Min six standard min, eight with Option 06.

ORDERING INFORMATION

4631 Hard Copy Unit \$5575

4632 Video Hard Copy Unit \$5575

COMMON OPTIONS

Option 01 Copy Counter Add \$100
Option 02 Four-Channel Multiplexer Add \$600

INTERNATIONAL POWER CORD AND PLUG OPTIONS

Option A1 Universal Euro 220 V/16A No Charge
Option A2 UK 240 V/13A No Charge
Option A3 Australian 240 V/10A No Charge
Option A4 North American 240 V/15A No Charge
Paper — One roll, 006-1603-00 \$73
One case of four rolls, 006-1603-01 \$250

4631 ONLY OPTIONS

Option 31 Compatible with the 4025 Terminal .. No Charge

4632 ONLY OPTIONS

Option 03 Setup for 625 Line, 50 Hz No Charge
Option 04 Setup for 1029 line, 60 Hz No Charge
Option 05 Setup for 4023 Terminal No Charge
Option 06 Enhanced Gray Scale Add \$800
Option 07 Compatible with HP 2640 Series
Terminals Add \$350
Option 08 Compatible with DEC MINC Systems No Charge
Option 09 Setup for AT&T GEMINI 100 Systems \$60

OEM terms available on these products.



NEW

4643

Low Cost Printing

Flexible for Many Applications

Crisp, Matrix Quality Printing

Easy to Use

International Characters

High Reliability

With high reliability built-in, the 4643 is a convenient and economical choice requiring no preventive maintenance and infrequent servicing.

Fast but not expensive, the 4643 Printer uses bi-directional logic technology to print 340 characters per second. With a full 132 character line, speeds of 125 lines per minute are nominal.

Virtually no maintenance means an even greater savings, and less downtime for repairs as well. A diagnostic display and self-testing routine virtually eliminates the need for preventive maintenance calls.

The expected (head) life is more than 300 million characters with no maintenance. This figure normally means at least two full years of continuous work from a single matrix head. The fabric ribbon, continuous loop cassette is usable for at least 5 million characters. Both the matrix head and ribbon cassette are quickly operator-replaceable eliminating the need for a service call.

High quality matrix printing is assured by the unique 14-wire printing head. The 7 by 7 format print font permits easy reading and the operator can specify condensed, expanded or standard characters. In the condensed (character) face, the 4643 prints out a 132-character line format on an 8 1/2 by 11 in sheet. Because the 4643 uses impact printing, six very legible copies (including five NCR or carbon copies) can be made to save time and avoid the expense of photo copies.

Compatibility. The printer of choice for high technology systems, the standard Tektronix 4643 is RS-232 compatible and can be interfaced with most standard RS-232 data processing instruments and systems. Option 01 provides a parallel interface. The 4643 is compatible with the following Tektronix products: 4010 Series Computer Display Terminals, 4025A Terminal, and 4050 Series of Desktop Graphic Computers; the 8001 and 8002A Microprocessor Labs and 8550 Microcomputer Development Lab; the S-3250, S-3270 and S-3280 Semiconductor Test Systems; the 7612D and 7912D Programmable Digitizers, and the 7854 Oscilloscope.

STANDARD ACCESSORIES

Ribbon Cassette (118-1314-00) RS-232 Interface

ORDERING INFORMATION

4643 Printer (2400 Baud Standard) ... \$4200
 Option 01 — Parallel interface No Charge
 Option 02 — Specify Baud Rate (110, 150, 300, 600, 1200, 4800, 9600) No Charge

OPTIONAL ACCESSORIES

Pedestal (118-1335-00) \$185
 Paper Basket (118-1316-00) \$80



4642

Fast printer output is yours at low cost with the TEKTRONIX 4642 Matrix Printer. This tabletop printing unit offers 60 character-per-second output speed, along with a variety of print alternatives. It is compatible with the TEKTRONIX 4020 Series of Computer Display Terminals and 4050 Series of desktop computers. Interface is standard RS-232C.

A variety of type faces. The 4642 gives the operator a varied selection of upper and lower case type faces. The standard format prints in 80 columns, and provides a choice of regular and elongated characters. A condensed character set, selectable from a front panel switch, gives 132 column output, and again, a choice of regular or elongated characters. Characters are formed on a 5 x 6 dot matrix.

Compact, easy to use. The 4642 requires minimum space for operation. Paper feed is by friction on the standard version, which uses inexpensive roll paper. The optional tractor feed paper drive can be used with both fanfold paper and multipart forms.

A choice of features. A complete selection of features and accessories can make the 4642 Matrix Printer even more versatile. For example, Option 01, a rear feed tractor paper drive option, allows output of an original and four copies. A printer stand is available to convert the 4642 to a floor unit. The 4642-1 is the 220 V ac, 50 Hz version of the 4642. All options and accessories are identical.

ORDERING INFORMATION

4642 Matrix Printer \$2900
 Option 01 Rear Feed Tractor Assembly Add \$280
4642-1 Matrix Printer \$2900
 Option 01 Rear Feed Tractor Assembly Add \$280



4907 File Manager

The 4907 is a direct access flexible disc device with a double density read/write feature that enables up to 630k bytes capacity per disc.

An advanced multiple level file-by-name system includes a directory that maintains the user files, passwords and available space. For applications requiring additional storage capacity, several drives may be connected to the file manager. Software commands are extensive with this file manager and its compact size is small enough to let it fit on a desktop or lab bench.

Built-in ROMs and special 4050 Series Desktop Computer's ROM Packs contain the 4907 operating system software. No 4050 Series Memory is required to support the operating system. The 4907 can also be used with some of the 4010 Series of graphic terminals.

ORDERING INFORMATION

| | |
|---|---------------|
| 4907 File Manager | \$5280 |
| Option 30 Two Disc Drives Total | Add \$3000 |
| Option 31 Three Disc Drives Total | Add \$4550 |
| Option 40 4052/4054 Interface | No Charge |

OEM terms available on these products.



4924 Digital Cartridge Tape Drive

4923 Digital Cartridge Tape Recorder

Both digital recorders are highly reliable, very easy to use for data storage and retrieval. The 4923 contains an RS-232C interface which supports any compatible computer display terminal from 110 to 9600 baud.

Each tape cartridge can store approximately 300k bytes of high density digital data. Files of variable length and files containing a variable number of formatted records can be easily stored by these two storage systems.

The 4924 offers a tape fetch feature and terminal interrupt capability and can operate with Tektronix graphics terminals via the terminal IEEE-488 bus. Transfer data rates are 10k baud max. Read data operates at 762 mm/s (30 in/s) and the Fast Forward Mode allows you to skip forward or reverse at 2290 mm/s (90 in/s). Up to 15 4924 tape drives may be multiplexed to any 4050 Series Desktop Graphic Computer at any one time.

ORDERING INFORMATION

| | |
|--|---------------|
| 4923 Digital Cartridge Tape Recorder . | \$2600 |
| Option 01 RS-232-C | No Charge |
| 4924 Digital Cartridge Tape Drive | \$2990 |



4952 Joystick

For desktop computer users needing increased interactivity, the 4952 Option 02 Joystick is the last word in fingertip input control. Accurate to 0.1%, the sensitive cursor control activated by the POINTER command lets you quickly position the cursor the first time precisely.

More to build on, less to repair. By entering a command in BASIC the 4952 Joystick will put the pointer on-screen and initiate movement. Drift is negligible.

The 4952 is simplicity itself. Just move the center lever in the direction you want to move the cursor; speed is controlled by the angle and distance of the lever from the center position. And when you want to stop the cursor, simply release the lever to its natural vertical position.

Compatibility for the Joystick is assured with all terminals in our 4010 family, 4081 Interactive Graphic Systems and 4050 Series Desktop Computers.

ORDERING INFORMATION

| | |
|--|--------------|
| 4952 Joystick (4014/4015) | \$590 |
| Option 01 Joystick (4010, 4012/4013) | Add \$75 |
| Option 02 Joystick (4050 Series) | Add \$100 |

OEM terms available on these products.



4634 Imaging Hard Copy

Photographic Quality Images

Excellent Gray Scale and Copy Quality

Compatible with Most Raster Scan Video Systems

Dry, Quick, Convenient Process

Large, File-Sized Image

The TEKTRONIX 4634 Imaging Hard Copy Unit is designed to record images of photographic quality from raster scan video sources. It is suited to a variety of industrial, commercial and medical imaging applications.

The 4634 is easily coupled to video sources. It can be adjusted to accommodate a wide range of line rates: from 525-1029 lines interlaced, and from 256-512 lines non-interlaced for both 50 Hz and 60 Hz systems. If image size is reduced, higher line rates are achievable.

The 4634 is available as either a rackmount or benchtop model. The rackmount version fits into any standard 482.6 mm (19 inch) rack.

The 4634 uses a cathode ray tube (CRT) to expose the image on dry silver paper. A fiber optic faceplate on the CRT effectively couples the light output to the paper, providing photographic quality images of fine detail.

After exposure, the image is developed in a thermal processor. The entire process of exposure and development is completed in just 26 seconds. The costs of space, equipment, and labor associated with wet process films are eliminated.

Users may select two types of paper: standard performance for lowest cost per image, and high performance for optimal image quality. Both paper types are significantly less expensive than film.

The combination of high image quality, operational simplicity, speed and convenience, and low cost makes the 4634 Imaging Hard Copy Unit an excellent choice for a wide variety of raster scan video applications.

CHARACTERISTICS
RECORDING MEDIUM

Material — Dry Silver Paper — High Performance Tektronix Standard Paper.

Paper Roll Length — 152 m (500 ft).

Paper Roll Width — 216 mm (8.5 in).

GENERAL PERFORMANCE CHARACTERISTICS

Warmup Time — 20 min.

Image Format — Horizontal scan lines in direction of exiting paper motion.

Gray Shades — 12 with High Performance Paper
6 with Standard Paper.

PHYSICAL CHARACTERISTICS

| Dimensions | mm | | in | |
|------------|-------|--|-------|--|
| | | | | |
| Height | 265.8 | | 10.47 | |
| Length | 685.8 | | 27 | |
| Width | 425.4 | | 16.75 | |
| Weight | kg | | lb | |
| | | | | |
| Net | 30.5 | | 67 | |

ORDERING INFORMATION

4634 Imaging Hard Copy Unit \$8400

Option 30 Delete Rackmount Hardware Sub \$85

Option 45 END-USER set-up No charge

High Performance Paper One roll, 006-2432-00 \$165

One case of four rolls, 006-2432-01 \$560

INTERNATIONAL POWER CORD AND PLUG OPTIONS

Option A1 Universal European 220V/16A No Charge

Option A2 United Kingdom 240V/13A No Charge

Option A3 Australian 240V/10A No Charge

Option A4 North American 240V/15A No Charge

SPECIAL PRICING, TERMS AND CONDITIONS ARE AVAILABLE TO QUALIFIED OEMS. CONTACT YOUR LOCAL TEKTRONIX REPRESENTATIVE FOR COMPLETE INFORMATION.

Tektronix offers maintenance training classes on Hard Copy Units and the terminals they support. For further training information, contact your local Sales Office or request a copy of the Customer Training Catalog on the return card.

4953, 4954, 4956 Graphic Tablets

With the 4953/54/56 Graphic Tablets, you can choose one of two input device options: a pen for best convenience, or a push-button cursor where exacting accuracy is required. You can input points or vectors to digitize or display maps, graphic drawings, schematics and other designs.

From precision mapping to exacting parts outlines, Tektronix Graphic Tablets satisfy a wide range of user needs. You can select options from a written "menu" placed on a Graphic Tablet. You can store graphic input on peripheral disc or recorder devices, recall it later, and make quick, dry-process copies on a Tektronix hard copy unit.

And Tektronix offers all of the pieces you'll need with your computer for a truly interactive graphics system. Take your pick of the 279 mm x 279 mm (11 in x 11 in) 4953 model, the drawing board-sized 1016 mm x 762 mm (40 in x 30 in) 4954 model, or the 4956 in two sizes. The 4956 is an IEEE-488 device which connects to the 4050 Series Desktop Computers. Standard is 510 mm x 510 mm (20 in x 20 in) and the Option 33 version is 910 mm x 1220 mm (36 in x 48 in). The latter version is large enough to accommodate E-size engineering drawings. Power modules are compact to help curb desktop clutter for all these graphic tables.

ORDERING INFORMATION

4953 Graphic Tablet 279 mm x 279 mm (11 in x 11 in) \$3795

Cursor, 119-0622-00 \$315

4954 Graphic Tablet 1016 mm x 762 mm (40 in x 30 in) \$6190

4954F32 Pedestal \$1325

Cursor, 119-0622-00 \$315

4956 Graphic Tablet 20 in x 20 in (510 mm x 510 mm) \$5670

Option 33 Graphic Tablet 36 in x 48 in (910 mm x 1220 mm) Add \$2600

Cursor, 119-0875-00 \$365

OEM PRODUCTS

CONTENTS

| | |
|--|-----|
| Specifications & Packaging | 95 |
| 634 Video Display | 96 |
| 608/624 Direct Viewing Display | 97 |
| 620 Waveform Display | 98 |
| GMA 103 19-inch Display Module | 99 |
| GMA 101A/102A 19-inch Display Module ... | 100 |
| GMA 125 25-inch Display Module | 101 |
| 4633A Continuous Recorder | 101 |

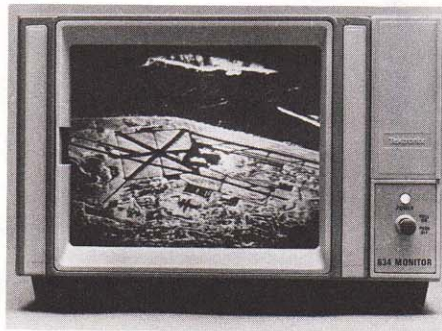

634 Video Display at 945/60 line rate

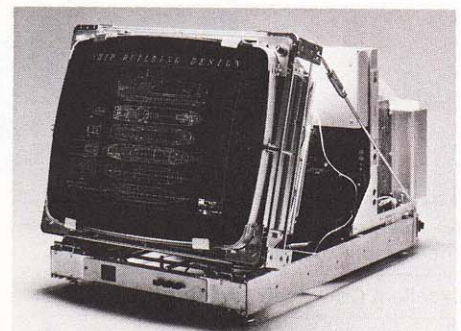

GMA 103 OEM Computer Display

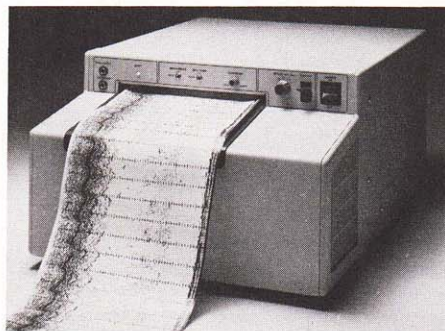

4633A Continuous Recorder



634 Video Display with aerial reconnaissance

The Tektronix OEM Commitment

Reliability. Performance. Value. Support.

When you deal with Tektronix, you're dealing with a supplier who stands behind you every step of the way. As a world leader in display technology, we're committed to building lasting OEM relationships and supporting them with continuing new product developments.

Your Tektronix resource starts with a broad and comprehensive package of OEM support: OEM pricing, terms and conditions to help make you competitive. OEM service agreements and service capability throughout the United States and in many countries. Applications engineering including interface assistance, custom mods, documentation, software compatibility, and much more.

At Tektronix, our product reliability is your foundation. Your systems can only be as reliable as the components that go into them. At Tektronix, we're committed to producing the most dependable components possible. You can be confident that the reliability we engineer into every component can help keep your customers satisfied and your service costs down. That's quality you can bank on.

Leadership in systems must begin with leadership in components. Explore the advantages of working with Tektronix: excellence in products, in OEM support, and service. Your local Tektronix OEM Representative can give you full details on how you can profit from a partnership with Tektronix.

The standard displays come without a handle, feet or covers. See your local Tektronix Representative for complete specifications, options and ordering information, or use the return card.

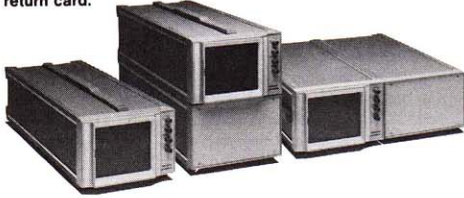

MODULAR PACKAGING AND RACK MOUNTING PACKAGING FOR THE 620

Vertical package. Includes handle, feet and covers. Order 016-0409-00 \$215

Horizontal package. Includes handle, feet and covers. Order 016-0410-00 \$215

Rackmount kits for the 620
Slide-out 19 in rack assembly which rackmounts one 620 and an empty compartment horizontally. In the compartment you may put your custom electronic circuitry and combine it with the display. Includes frame, covers and rack slides. Not available with Options 06, 23, 28. Order 016-0404-00 \$245

Slide-out 19 in rack assembly which rackmounts two 620s side by side. Includes covers and rack slides. Not available with Options 06, 23, 28, 31. Order 016-0405-00 \$215

Small-width packaging. Smaller-width packaging removes controls (intensity, focus, spot position) from the right side of the CRT. Allows OEM to mount elsewhere in this system. Request quote from your Tektronix representative.

RACKMOUNTING FOR 606B, 608, 624

Rackmount and Empty Cabinet Kit for 606B, 608, and 624. Slide-out 19 in rack assembly which mounts a display monitor and an empty compartment horizontally. In the compartment you may put your custom electronic circuitry and connect it to the display, all in one enclosure. Order 040-0601-00 \$290

Display/Power Module Kit. Allows rackmounting of 606B, 608, and 624 with TM 503 Power Module. Minimizes mechanical design time. Simply design your own electronics using TM 500 Custom Plug-in kits described on p. 298. Then plug them in. Fits standard 19 in rack. Order 040-0624-01 \$90

Rackmounting kit for 606B, 608, and 624. Slide-out 19 in rack assembly which rackmounts any two of the above displays side by side. Includes covers and rack slides. Order 040-0600-00 \$180

Rackmount-to-Cabinet Conversion, required to convert a rackmount 606B, 608 and 624 to a cabinet style. Order 040-0602-00 \$160

KEY SPECIFICATIONS FOR X-Y DISPLAYS

See your local Tektronix representative for complete specifications, options and ordering information, or use the return card.

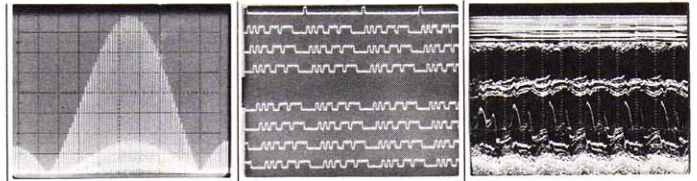

| | 608 | 620 | 624 |
|---|--|--|-------------------|
| Spot Size ¹ | 0.26 mm (10 mils) | 0.38 mm (15 mils) | 0.30 mm (12 mils) |
| Display Size | 9.8 x 12.2 cm | 10 x 12 cm | 9.8 x 12.2 cm |
| Acceleration Potential | 22.5 kV | 12 kV | ≈18 kV |
| Bandwidth, X-Y ² | ≥5 MHz | ≥2 MHz | ≥3 MHz |
| Bandwidth, Z ² | ≥10 MHz | ≥5 MHz | ≥5 MHz |
| Rise Time | ≤35 ns | | ≤70 ns |
| Input R and C, X-Y ³ | 1 MΩ, ≤60 pF | 1 MΩ 47 pF | 1 MΩ <47 pF |
| Input R and C, Z ³ | 1 MΩ, ≤60 pF | 1 MΩ <47 pF | 1 MΩ <47 pF |
| X-Y Phase Difference | ≤1° to 1.5 MHz | ≤1° dc to 500 kHz | <1° to 1.0 MHz |
| Recommended Source Impedance, X-Y and Z | ≤10 kΩ | ≤10 kΩ | ≤10 kΩ |
| Temperature Range | 0°C to +50°C | 0°C to +50°C | 0°C to +50°C |
| Power Requirements ⁴ | 61 W | See footnote ⁴ | 61 W |
| Included Accessories | Lined external implosion shield (graticule) for adjustment purposes. | Lined external implosion shield (graticule) for adjustment purposes. | |
| Recommended Cameras ⁵ | C-5C, C-59A, C-28 | C-5C, C-5C Opt. 01, C-28 | C-5C, C-28 |

- ¹ Measured at 0.5 μA.
- ² Full spec would read: "dc to . . ." appropriate figure.
- ³ "|| <" means "paralleled by less than".
- ⁴ Line voltage selector allows operation from 100, 110, 120, 200, 220, and 240 V (±10% on each range). 48 to 440 Hz (except the 624 which excludes 220). Number given shows watt max at nominal line voltage. The 620's power requirements are 90-132 and 180-250 V ac; 48-440 Hz line frequency. 22 W max. 0.2A at 120 V ac 60 Hz.
- ⁵ External 15 V dc 750 mA power supply required for C-28.

APPLICATIONS FOR SELECTED OEM IMAGING PRODUCTS

KEY SPECIFICATIONS FOR 634 VIDEO DISPLAY

| Video Display | 634 | 634 Opt. 01 | |
|----------------------------------|--|-------------|----------|
| Resolution | Worst case | 1100 line | 650 line |
| | Nominal | 1400 line | 800 line |
| Display Size | 9x12 cm (flat screen) | | |
| Position Accuracy/ Non-Linearity | ≤0.5% within 9 cm circle, ≤1% in corners. For Option 01: 1% within 9 cm circle, 2% at corners. | | |
| Brightness | 515 cd/m ² (150 fL) max. | | |
| Brightness Non-uniformity | Less than ±10% | | |
| Bandwidth | 1 Hz - 10 MHz std. 20 MHz Video bandwidth available as Option 14. | | |

Note: Standard 634 accepts the line/field rate of 525/60 and 625/50. Discrete line rates of 675/60 through 1083/60 can be accommodated using option 15. *Merged raster lines.

| Recommended Display | Medical Instrumentation | Electronic Test Equipment | Defense Electronics | Analytical Instrumentation |
|--|--|--|--|--|
| 634 Very High Resolution Video Display | Ultrasound raster scan Computerized tomography Multi-imaging cameras | High-density graphics, alphanumerics and imaging | Reconnaissance & surveillance Target acquisition FLIR LLLTV | Electron microscopy |
| 608 High Brightness X-Y Display | Ultrasound M-Mode Real time Sector scan B-scan | Spectrum analysis | Navigation and control Automated test systems Simulators IR imaging | Mass Spectrometry Nondestructive testing NMR FTIR |
| 620 General Purpose X-Y Display | Ultrasound: A-mode Physiological measurements | Logic analyzers Automated test equipment Spectrum analysis RF-sweepers TV waveform monitor | Electronic counter-measures Radar-A scopes Sonar PPI | Nondestructive testing Multi-channel pulse height analyzers |

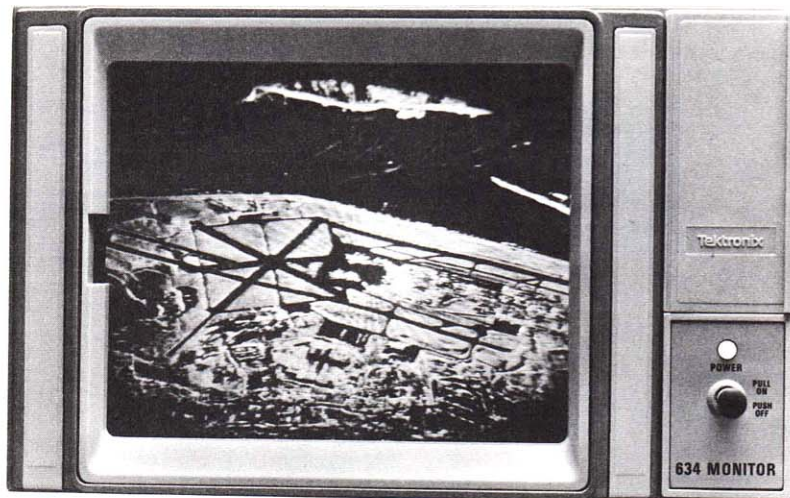

634

High Resolution Video Display for Critical Applications (1400 lines, shrinking raster)

< 1/2% Non-Linearity Inside the 9 cm Quality Area

Excellent Gray Scale and Brightness Uniformity

Extremely High Resolution, Low Distortion Displays for Demanding Applications.

The 634 raster scan monitor delivers extremely high quality video images for both viewing and photography. Applications include: medical diagnostic imaging, military infrared imaging, and automated test systems.

The 634 has been specifically designed to deliver the superior performance required to meet those demands.

Textronix distortion requirements surpass normal standards. With the 634, you'll have less than 1/2% distortion inside the 9 cm quality area. Outside: less than 1%. And the 634 has an optically flat screen to preserve geometric correctness in viewing and photographic applications.

Resolution vastly outperforms other monitors. Resolution on video displays can be separated into two categories: Vertical and horizontal.

Vertical resolution, of course, is limited by the video line rate used. At the RS-170 rate of 525/60, approximately 480 lines are visible. Option 15 extends the 634 line rate to 1083/60, and accordingly improves the vertical resolution.

When we talk about the 634's 1400-line nominal horizontal resolution, we're only counting the white lines. If we added all the black and white lines, that resolution would approximate 2800 lines. And that far surpasses anything else on the market. In addition, dynamic focusing assures crisp images, even in the corners.

Optimum gray scale. The 634 is designed to faithfully display gray scale images on its P45 CRT. Because of the demanding performance required by our engineers, the CRT was designed by Tek Labs, and utilizes an advanced gun

design. Excellent brightness uniformity — (variation is less than $\pm 10\%$ across the screen) means that results are consistent from point to point on the screen.

Built for the job. The 634 is not an upgraded television monitor. It has been conceived, designed and constructed as a high-precision imaging display. Its design continues the tradition of superior CRT technology expertise developed by Tektronix.

The sliding panel packaging optimizes service access and each instrument is fully calibrated to strict Tektronix standards before leaving the factory.

Safety Options. The 634 is available with safety options. UL 544 (Medical/Dental) listing, for stand-alone applications, includes covers and feet. You may select the UL 544 Component Recognition option if you intend to house the 634 in your system. Certifications required by many other industries or governments are also available.

Optional features. You may also order an optional video reverse feature which provides black on white or white on black imaging. This is particularly valuable in medical imaging, where many doctors prefer to view the scan as a black image on a white background. Manual or TTL levels will activate video reversal.

A remote-programming option permits control of contrast, brightness focus and blanking by the user's system. And there is a dc option that eliminates the ac power supply, lowering weight, cost and power consumption, while permitting operation from your system's dc power.

Qualified OEMs may also order the 634 with certain custom modifications including matching colors. See your Tektronix representative for complete applications assistance and pricing.

High line rate capability. The 634 is available, on a standard basis, at 525/60 and 625/50 rates. Common rates of 675/60, 875/60, 945/60, 1023/60 and 1083/60 can be accommodated using Option 15. These higher rates allow the systems builder maximum flexibility in selecting desired vertical resolution. The optionally available 20 MHz video amplifier is recommended for use with high line rates.

CHARACTERISTICS

DISPLAY PERFORMANCE

Monochrome CRT Display — 9 cm vertical; 12 cm horizontal; 15 cm diagonal (6 in.); flat screen, magnetic deflection; 4 x 3 aspect ratio.

Resolution — Measured by the shrinking raster method with no interlacing, center screen at 100 cd/m² (30 fL) (merged raster lines, not TV lines).

634 — 1100 lines, worst case; 1400 lines, nominal.

634 Option 01 — 640 lines, worst case; 800 lines, nominal.

Position Accuracy/Non-Linearity —

634 — $\leq 0.5\%$ within 9 cm circle, $\leq 1\%$ in corners.

634 Option 01 — $\leq 1\%$ within 9 cm circle, $\leq 2\%$ in corners.

Brightness — 515 cd/m² (150 fL) maximum.

Brightness Uniformity — Better than $\pm 10\%$ over the scan area, measured by J16 Photometer.

Phosphor Type — P45.

VIDEO INPUT

Description — Composite video with negative sync. RS-170 compatible.

Signal Level — 0.35 V p-p to 2 V p-p.

Maximum Safe Input — ± 5 V p-p.

Bandwidth 634 — 1 Hz to 10 MHz

634 Option 14 — 1 Hz to 20 MHz.

Impedance — 75 Ω with loop through and switchable termination.

Return Loss — 46 dB to 5 MHz with internal 75 Ω termination and power on.

Dc Restoration — Referenced to back porch.

RASTER

Vertical Rate — 50 to 60 Hz.

Horizontal Rate 634 — 15,750 Hz.

634 Option 15 — 32,490 Hz, adjustable $\pm 10\%$.

Note: Our standard instrument will accept the line/field rate of 625/50. With Option 15, parts are supplied to permit setup at rates between 675/60 and 1083/60 (RS-343A compatible). Contact your Tektronix Sales Engineer for further information.

SAFETY

Department of D.H.H.S. (BRH Rule 1020 10 (C) (1) standard, UL 544 Listing (Option 06) and UL 544 Component Recognition (Option 09). C.S.A. certified.

ORDERING INFORMATION

634 Video Display \$2900

With standard resolution of 1400 merged raster lines nominal, 1100 line worst case (center screen at 100 cd/m²(30 fL), without handle feet and covers.

Option 01 Sub\$60

Standard resolution of 800 merged raster lines nominal, 650 lines worst case (center screen at 100 cd/m [30 fL])

PERFORMANCE OPTIONS

Option 11 External Sync—switchable Add \$40

Option 13 Video Reverse Add \$85

Option 14 20 MHz Video Amplifier Add \$145

Option 15 High Line Rate. Factory calibrated at 1083/60.

User changeable to rates between 675/60 and 1083/60 with supplied parts kit Add \$280

Option 16 Remote Brightness, Contrast, Focus, Video Reverse, Blanking Add \$60

Option 20 Dc Supply— +23 V, -22 V, +9 V

(unregulated) Sub \$20

SAFETY OPTIONS

Option 06 UL 544 Listing (covers included; not available with Options 20 or 28) Add \$100

Option 09 UL 544 Component Recognition No Charge

MECHANICAL PACKAGE OPTIONS

Option 23 Handle, Feet and Covers (not available with Options 06, 20 or 28) Add \$80

Option 28 Covers only (not available with Options 06,20,23).

Rackmount kit to mount two 634s side by side in 19 in rack.

Not compatible with Option 20. 016-0403-00* \$215

Rackmount Kit to mount one 634 and one empty cabinet side by side. Not compatible with Option 20.

016-0402-00 \$265

*OEM PRICING NOT AVAILABLE ON RACKMOUNT KITS. QUANTITY DISCOUNT INFORMATION IS AVAILABLE ON REQUEST.

SPECIAL PRICING, TERMS AND CONDITIONS ARE AVAILABLE TO QUALIFIED OEMS. CONTACT YOUR LOCAL TEKTRONIX REPRESENTATIVE FOR COMPLETE INFORMATION.

608/624

High Brightness X-Y Displays

Ambient Light Viewing

High Resolution

Expansion Mesh Halo Suppression

Excellent Gray Scale

Optional UL 544 Listing

The 608 is our finest directed beam viewing monitor. It is extremely well suited for high performance display applications, such as medical and military imaging and electronic instrumentation. The related 624, a comparable but more economical alternative, provides excellent direct viewing capability for systems that require good performances at a more favorable price. The 608's high usable brightness of up to 240 cd/m² (70 fL), a 0.25 mm (10 mil) spot size, and large 9.8 x 12.2 cm screen, all combine to give you optimum viewing capability. Where such a high degree of clarity or brightness is not required, we recommend the 624 with a 0.3 mm (12 mil) spot size, display brightness of 135 cd/m² (40 fL), and a screen size of 9.8 x 12.2 cm. Both instruments produce detailed displays that are easy to read in high ambient light and that result in quality photographs.

Special CRT design suppresses expansion mesh halo. Characteristic of both instruments, this suppresses secondary electron emissions, the annoying stray light that ordinarily gives lower contrast and a "washed out" appearance that interferes with high brightness gray scale displays.

Expansion mesh halo suppression results in a more readable display with subtle and accurate gray scale gradation for precise measurement or analysis.

High resolution. The 608 displays both excellent gray scale images and detailed waveform displays, thanks to its small 0.25 mm (10 mil) spot size (0.3 mm or 12 mils for the 624). In addition, imaging is critically sharp from corner to corner particularly on the 608, which utilizes dynamic focusing.

A wide range of options for broad interface capability. You may order your 608 or 624 with an internal graticule with 8 x 10 divisions, etched on the inside of the screen for minimal parallax. Other options facilitate control of either display by your system. The TTL blanking option blanks the Z axis with any TTL logic source. And an optional 25-pin connector permits connection of X, Y and Z input signals.

The wide deflection factor—adjustable from 50 mV/div to 0.25 V/div (up to 1.25 V/div with extended gain range option)—facilitates integration with a broad range of designs. An optional metal bezel lets you use heavy cameras, including those with motorized roll film backs, without causing distortion, defocus or light-leaks.

In addition, optional full differential inputs help reject unwanted common-mode signals such as ground noise and power supply hum. Additionally the 608 can be ordered with a gamma correction option for photographic applications: This produces linear light output changes with a linear change of Z-axis input, typically within 20 percent.

Both the 608 and 624 are available with UL 544

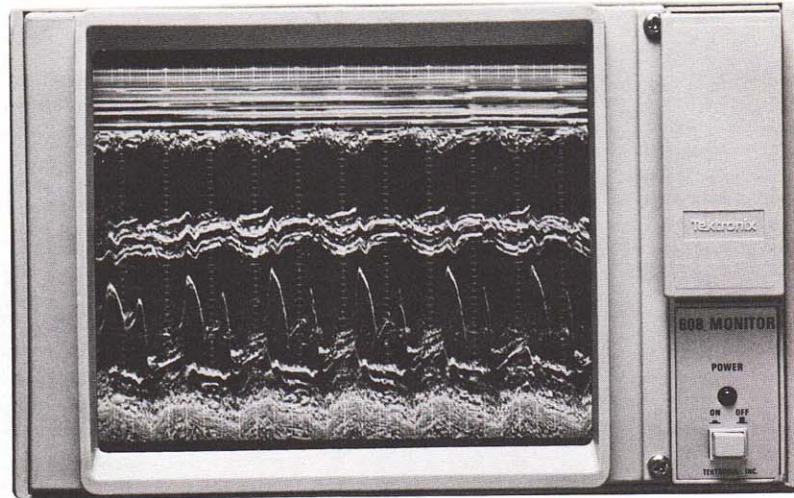

Listing. Handle, feet and covers are included. If you house the 608 or 624 in your system you may select UL 544 Component Recognition.

Packaging further expands flexibility. Packaging option include carrying handle, protective covers and feet. Rackmount kits can also be ordered for either 608 or 624, further extending packaging versatility, and providing space for your electronic circuitry.

CHARACTERISTICS

CRT DISPLAY

Cathode Ray Tube — Flat-faced, electrostatic deflection. P31 Phosphor standard.

Display Size — 9.8 cm vertically, 12.2 cm horizontally. Internal graticule is available without charge (Option 01) with 8 x 10 divisions (1.22 cm/div).

Display Linearity — The voltage required to produce a 2.5 cm deflection at any point on the CRT will not vary more than 5%.

Spot Size — 608 — 0.25 mm (10 mils) at 170 cd/m² (50 fL), with maximum usable brightness of 240 cd/m² (75 fL). 624 — 0.3 mm (12 mils) at 170 cd/m² (50 fL).

Acceleration Potential

608 — 22.5 kV overall.

624 — ≈ 18 kV overall.

VERTICAL AND HORIZONTAL AMPLIFIERS

Bandwidth 608 — Dc to ≥ 5 MHz.

624 — Dc to ≥ 3 MHz.

Deflection Factor — Adjustable < 50 mV/div to > 0.25 V/div. Option 22 (5X attenuator) extends deflection factor to > 1.25 V/div.

Input R and C

608 — 1 MΩ paralleled by < 60 pF.

624 — 1 MΩ paralleled by < 47 pF.

X-Y Phase Difference

608 — Not more than 1° to at least 1.5 MHz.

624 — Not more than 1° to at least 1.0 MHz.

Maximum Input Voltage — ± 100 V (dc plus peak ac).

Linear Common-Mode Signal Range (with Option 21) — ± 3 V, nonattenuated. (Option 22 extends range 5X to ± 15 V.)

Common-Mode Rejection Ratio (with Option 21) — At least 100:1 from DC to at least 100 kHz. Option 22 (5X attenuator) reduces cmrr to 40:1 to 100 kHz.

Recommended Source Impedance — 10 kΩ or less.

Z-AXIS AMPLIFIER

Z-axis amplifier permits intensity modulation of the writing beam.

Bandwidth

608 — Dc to 10 MHz over the usable range.

624 — Dc to 5 MHz over usable range.

Sensitivity range is adjustable from 0 to +1 V to 0 to +5 V for full intensity control. Zero V input cuts off intensity with front panel control at midrange.

Input R and C

608 — 1 MΩ ± 1% paralleled by < 60 pF.

624 — 1 MΩ ± 1% paralleled by < 47 pF.

Linear Common-Mode Signal Range (with Option 21) — ± 5 V, nonattenuated.

Common-Mode Rejection Ratio (with Option 21) — ≥ 100:1 to 100 kHz.

ORDERING INFORMATION

608 Display \$2690
(without handle feet or covers)

624 Display \$2640
(without handle, feet or covers)

PERFORMANCE OPTIONS

Option 10 25-pin Remote Program Connector X, Y and Z, single ended inputs Add \$50

Option 20 Without ac supply (± 18 V unregulated dc supply required. (Not available with Option 06) (624 only) Sub \$30

Option 21 Full Differential Inputs (X, Y, and Z) Add \$50

Option 22 5X Attenuators Add \$35

Option 24 Linearized Z-Axis (Gamma Correction) (608 only) Add \$75

Option 25 TTL Blanking Add \$75

SAFETY OPTIONS

Option 06 UL 544 Listed, includes handle, feet and covers Add \$100

Option 09 UL 544 Component Recognition No Charge

MECHANICAL PACKAGING OPTIONS

Option 01 Internal graticule No Charge

Option 23 Handle, Feet and Covers (not available with Options 06 and 28) Add \$80

Option 28 Covers only (not available with Options 06 and 23) Add \$70

Option 29 Metal Bezel Add \$70

Rackmount kit to mount two 608s or 624s side by side, or one 608 or 624 and a 606B side by side in a 19 in rack. Order 040-0600-00 \$180

Rackmount kit to mount one 608 or 624 and one empty cabinet side by side in a 19 in rack. Order 040-0601-00 \$290

SPECIAL PRICING, TERMS AND CONDITIONS ARE AVAILABLE TO QUALIFIED OEMs. CONTACT YOUR LOCAL TEKTRONIX REPRESENTATIVE FOR COMPLETE INFORMATION.

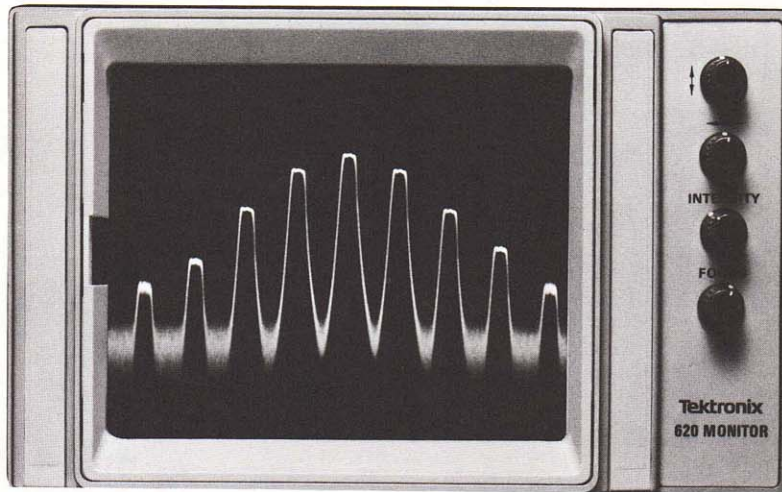

620

General Purpose X-Y Waveform Display

Many Packaging Options

Exceptionally High Reliability

The 620 can be used in any situation requiring an economical, X-Y waveform display. Electronic instrumentation applications include pulse height, network, spectrum, logic and signal analyzers and digitizers. The 620 is also used in mechanical measurement instruments for vibration tests and NDT. And in the medical field it is used for A-mode imaging. The 620 offers spot size of 0.38 mm (15 mils), a 10 x 12 cm screen, and usable brightness up to 100 cd/m² (30 fL).

Built-in reliability. The typical power requirement of about 22 watts means less power drain and a lighter weight power supply, so your overall system can be lighter, more compact, and generate less heat. An option allowing dc operation from your power supply further reduces power consumption and weight. By using fewer parts and lower power, display and system reliability are improved, and service costs can be lower.

Packaged the way you want it. The 620 comes with a wide variety of packaging options which allow you to easily integrate the display into your system.

620 standard package. Easily mounts in your custom cabinetry. The operator controls are conveniently positioned to the right of the CRT.

The 620 narrow package (Mod BD). Easy to install in your product. Mount in any position: Horizontal, vertical, angled or upside down. All electronics are on one side, for simplified interface and adjustments.

Once installed in your product, only the CRT screen and metal bezel show. Position the four operator controls wherever you want. Controls can even be mounted internally. Just 17.5 cm (6.9 in) wide, to save you space. Weighs only 3.5 kg (7.7 lb), to help make your product lighter.

The Display Narrow Package requires external dc power (+ 18 V to 26 V dc unregulated), which must be supplied by your system. Mod BD cannot be powered directly from ac sources. All power connections and input signals are made to interconnect pins inside the monitor. Connector pins and cables are supplied with the unit.

620 stand-alone package. With handle, feet and covers: An excellent choice for your remote monitor.

620 horizontal and vertical packages. An empty compartment next to or below the display provides space for your custom circuitry, resulting in an integrated enclosure. You can assemble this package for your product and save valuable development and tooling costs. The handle fits on top of the vertical package and on the side of your choice for the horizontal package. Option 31 allows you to use your own power supply and a single ac power cord.

620 rackmount package. Slide-out 19 in rack assembly mounts one 620 and one compartment for your electronics alongside. Or, you can mount two 620s side by side.

NOTE: While the 620 Display Narrow Package is configured for dc power only, the standard 620 is configured for ac power (built-in supply). It can also be configured for dc power.

Any 620 package can be ordered with UL 544 Component Recognition, for applications where the 620 is directly inserted into an OEM system. UL 544 Listing is also available and includes handle, feet and covers.

Comprehensive support services. All Tektronix displays are backed by a worldwide service network. Comprehensive, easy-to-read manuals and complete drawings are provided, and complete drawings are available to speed mechanical integration. Spare parts documentation is available to optimize serviceability and lower your spare parts inventory cost.

CHARACTERISTICS CRT DISPLAY

Cathode Ray Tube — 16.5 cm (6.5 in) flat-faced rectangular CRT with P31 Phosphor.

Spot Size — 0.38 mm (15 mils) at 0.5 μ A.

Display Size — 10 cm vertically, 12 cm horizontally.

Graticule — External graticule included as accessory. Internal 8 x 10 div (1.22 cm/div) graticule available as Option 01.

Display Linearity — The voltage required to produce a 2.5 cm deflection from any point on the CRT will not vary more than 5%.

Acceleration Potential — 12 kV.

VERTICAL AND HORIZONTAL AMPLIFIERS

Bandwidth — Dc to 2 MHz.

Setting Time — 1 μ s from any point on the CRT within 0.05 cm of final position.

Deflection Factor — Adjustable, ≤ 0.9 V to ≥ 1.5 V per 10 cm (vertical), ≤ 0.8 V to ≥ 1.2 V per 10 cm (horizontal).

Input R and C — 1 M Ω shunted by < 47 pF.

X-Y Phase Difference — $\leq 1^\circ$ dc to 500 Hz.

Max Input Voltage — ± 25 V (dc plus peak ac).

Recommended Source Impedance — 10 k Ω or less.

Z-AXIS AMPLIFIER

Linear Z-Axis — Amplifier permits intensity modulation of the writing beam. Positive input to + input increases the display intensity. Can be reversed by internal change.

Bandwidth — Dc to ≥ 5 MHz.

Input Sensitivity Range — Not adjustable. 1.0 V will produce maximum brightness with Intensity Control set at mid-range.

INCLUDED ACCESSORIES

External Graticule.

CABINET DIMENSIONS

(without modular packaging)

| Dimensions (without modular packaging) | cm | in |
|---|-----------|-----------|
| Height (without feet) | 13.26 | 5.22 |
| Width | 21.40 | 8.43 |
| Length | 50.04 | 19.70 |
| Weight (without handle, feet and covers) | kg | lb |
| Net | 5.33 | 11.75 |
| Shipping (without handle, feet and covers) | 6.89 | 15.2 |

MOD BD DISPLAY NARROW PACKAGE

The 620 Display Narrow package (Mod BD) is designed to be easily incorporated within your cabinetry.

CABINET DIMENSIONS FOR NARROW PACKAGE

| Dimensions | cm | in |
|--|-------|-------|
| Height (without feet) | 12.88 | 5.07 |
| Width | 17.46 | 6.88 |
| Length (overall) | 47.68 | 18.77 |
| OPENING NEED FOR BEZEL (\approx) | | |
| Height | 12.97 | 5.11 |
| Width | 14.14 | 5.11 |
| Cornerradii | 0.48 | 0.19 |

ORDERING INFORMATION

| | |
|--|------------------|
| 620 Display (without handle, feet and covers) | \$1400 |
| Option 01 Internal Graticule | No Charge |
| Option 06 UL 544 Listed includes handle, feet and covers | Add \$100 |
| Option 09 UL Component Recognition* (not compatible with Option 06) | No Charge |
| Option 10 Remote 25-pin program connector, X, Y, and Z-axes. Single ended inputs only. (Not available with Option 31) | Add \$50 |
| Option 20 Delete ac power. External dc power required (+17 to 26 V, ≈ 0.9A). (Not available with Option 06 or 31) | Sub \$25 |
| Option 23 handle, feet and covers (not available with Options 06, 28, 31 and modular packaging) .. | Add \$80 |
| Option 25 TTL Blanking* | Add \$50 |
| Option 28 With cover only—no trim strips (not available with Options 06, 23, 31 and modular packaging) .. | Add \$70 |
| Option 31 Delete all rear panel BNCs, dc power connector and ac power supply and switch. Option 31 includes provision for external dc power (+17 V unregulated). All power connections and input signals are made to interconnect pins inside monitor. Not compatible with Options 06, 10, 20, 23 and 28. Can be used with 016-0409-00 or 016-0410-00 packaging | Sub \$25 |
| 620 Mod BD Display Narrow Package, without handle, feet and covers. Dc power only. Request quote. | |

RACKMOUNT KITS

| | |
|--|--------------|
| Rackmount to one 620 in a 19 in rack. Includes frame, covers and rack slides. Not available with Options 06, 23, 28, Order 016-0404-00 | \$245 |
| Rackmount for two 620s side by side in a 19 in rack. Includes covers and rack slides. Not available with Options 06, 23, 28, and 31 Order 016-0405-00 | \$215 |
| *Also available for 620 Narrow Package. | |

MODULAR DRESS PACKAGING

| | |
|--|--------------|
| Vertical Package — Consists of empty compartment, connecting hardware, handle, feet, and covers Order 016-0409-00 | \$215 |
| Horizontal Package — Consists of empty compartment, connecting hardware, handle, feet, and covers Order 016-0410-00 | \$215 |

SPECIAL PRICING, TERMS AND CONDITIONS ARE AVAILABLE TO QUALIFIED OEMS. CONTACT YOUR LOCAL TEKTRONIX REPRESENTATIVE FOR COMPLETE INFORMATION.

NEW

GMA 103

19 Inch High Performance

Modular Graphic and Alphanumeric Display

Storage and Color Refresh Capability

The GMA 103 is a high performance member of the GMA display product family which provides the new feature of color enhanced refresh. The family features are: A) a blending of storage and refresh technology, B) modular construction and C) performance, interface and packaging options to configure a display to fit your application.

Color refresh for quick differentiation of refresh from stored information. The powerful combination of having storage and refresh display technology combined in one computer display module is further enhanced by the use of color. Stored information appears in the familiar green color while refresh data is displayed in a new yellow-orange hue. The result is that working files in refresh are easily distinguished from even the most dense fixed or more finalized stored files.

The dynamics of color enhanced refresh. The flicker-free data density and detail of storage. The GMA 103 will display up to 40 vector meters (1,575 vector inches) (30 Hz refresh rate) of refreshed data while simultaneously having all the benefits of storage technology. The storage mode presents high resolution, high density graphics at a low cost. Color refresh adds selective erase, interactivity and dynamic motion with the same high resolution of storage. By placing fixed or finalized data in store while retaining dynamic or working data in refresh, you can achieve high density, interactive graphics while making maximum use of your computer to address the application task rather than support the display.

Modular Construction. The CRT, low voltage power supply and printed circuit board modules are arranged on a unique high-strength wireform chassis. This construction not only supports different performance, interface and packaging options but permits easy removal of modules for field service.

Options Addressed to the OEM. The standard instrument is driven as an X-Y directed beam display using analog inputs. Space has been left in the card cage for you to add up to three circuit boards with your application options. Our Option 43 High Speed Vector/Dot Character Generator can be plugged into two of these positions to give you a completely digital interface (16 bit word format plus control and status signals). You

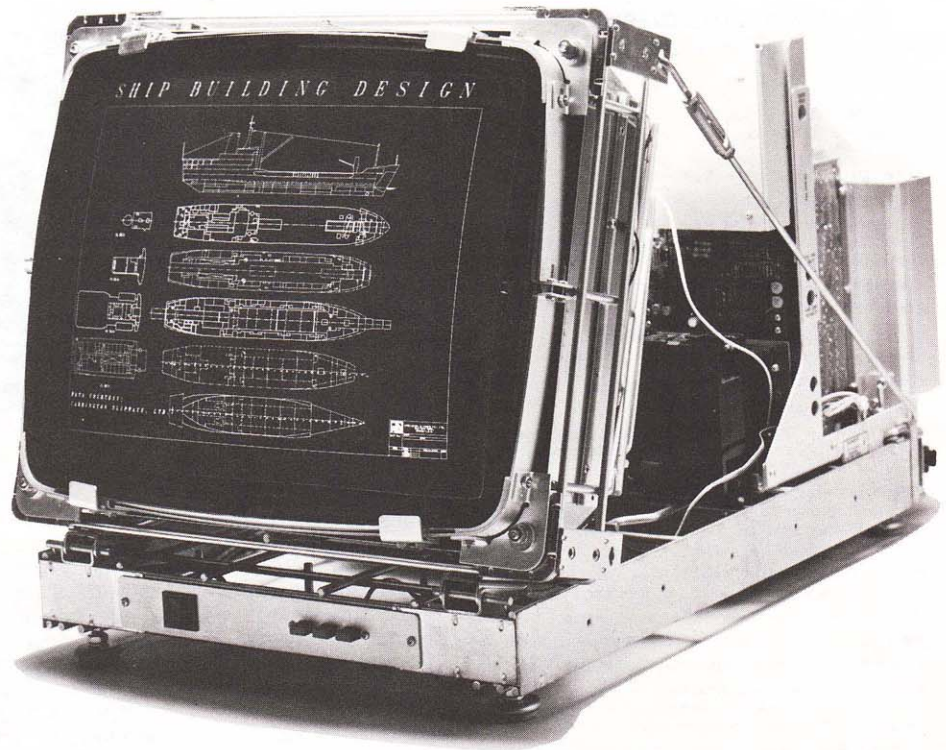

can use your interface connector or ask for our Option 34 (analog) or Option 35 (digital) connector as appropriate. The standard instrument has a colored glass filter and is compatible with Tektronix hard copy units. The display can be supplied with the CRT module tilted as far back as 15° and oriented in either the horizontal or vertical (page) format. Several support options are also available.

Operation. All display functions are completely programmable and designed to interface to TTL logic. The display functions are Write-Thru, Non-Store, Brite, Defocus, Center, Copy, Erase, View and G Busy. The X-Y inputs are analog, the beam resting at center screen with zero volts applied. The GMA 103 is completely compatible with other members of the GMA family. If refresh is already being used in a GMA family display, no new signals are required to support color refresh.

Write-Thru. Displays refreshed information on the screen concurrently with stored data.

Non-Store. Allows the GMA 103 to be used as a refresh-only display at a higher viewing contrast.

Defocus. Increases the spot size slightly. May be used in store or refresh modes.

Brite. Increases the intensity slightly for storing wide vectors or boldface characters. To be used in conjunction with DEFOCUS.

Center. Resets the origin shift circuitry used to protect the CRT during repeated over-write operation.

Copy. Initiates hard copy when attached to a TEKTRONIX 4611 or 4631 Hard Copy Unit.

Erase. Activates full screen erasure of stored information.

View. Switches the GMA 103 back to the View Mode after it has switched to the nonprogrammable Hold Mode.

Hold. Automatically activated to reduce the brightness of the stored display after 112 seconds of display inactivity, thus increasing CRT life. Supplying a positive-going edge to **G-BUSY** will prevent the display from dropping into the Hold Mode. Inputs on the **Z-AXIS** normally serve this purpose.

In addition to the control functions, other signals are provided by the GMA 103 to indicate status. **SLU** and **D-BUSY** are outputs provided to let the system know whether or not to send the display any additional data. If either of these signals is set true, another function is taking place and data should not be sent.

A CRT anti-burn circuit is provided to protect against burning the CRT phosphor in the event that X and Y deflection is not commanded to move or is lost with the writing beam on. In addition, the screen is automatically erased after 30 minutes from the last **Z-AXIS** or **G-BUSY** pulse or **VIEW** initiate, thus preventing residual images.

Special Performance or Packaging Requirements? Your local Tektronix Sales Engineer can describe all standard options, and put you in touch with Tektronix Application Engineers to resolve special requirements.

Continued overleaf

DISPLAY CHARACTERISTICS

CRT — 483 mm (19 in) diagonally measured Direct View Storage Tube.

Addressable Area — 267 mm x 356 mm (10.5 in x 14 in).

Stored Resolution — Screen Center, 157 line pairs/mm (40 line pairs/in). Screen periphery, 138 line pairs/mm (35 line pairs/in).

Stored Dot Writing Time — 5 μ s or less.

Stored Vector Writing Rate — 150 m/s (5900 in/s).

Refreshed Vector Writing Rate — (Write-Thru and Non-Store) 1200 m/s, (47,240 in/s), 40 vector meters, (1575 vector in) (maximum) at 30 frames/s.

Viewing Time — At least 15 minutes at specified resolution.

Erase Time — 1.5 s \pm 20%.

DEFLECTION AMPLIFIERS

X-Y Inputs — Differential.

Origin —

(X=0, Y=0 Volts) — Center screen.

Origin Shifter — Shifts display origin to one of eight locations. Resets to a beginning point after a Center command. Total travel is 4.5 mm (0.179 in).

Polarity (with respect to X-Y inputs) — X = long axis, Y = short axis, selected by jumpers: + V moves beam right (X) and up (Y) when applied to "+" inputs. -V moves beam left (X) and down (Y) when applied to "-" inputs.

Input Sensitivity — Long axis: 10 V p-p full screen \pm 2.5%. Short axis: 7.5 V p-p full screen \pm 2.5% of long axis.

Maximum Input Voltage — \pm 6.5 V (dc + peak ac).

Input Impedance — 10 k Ω \pm 10% paralleled by < 100 pF.

Slew Rate (non-linear operation) — 5000 m/s.

Settling Time (non-linear operation) — 1 μ s + 2 μ s/cm to within one spot diameter for vector lengths > 1 cm. 3 μ s to within one spot diameter for vector lengths \leq 1 cm.

Positional Accuracy — All points within the CRT addressable area are addressable with an accuracy of \pm 1.25% of the long axis dimension.

Z-AXIS

Input Requirements — TTL compatible. LO True. (Strap selectable to HI True).

Rise Time — 70 ns, limited to 1 MHz continuous repetition rate.

Input Impedance — 50 Ω . (Strap selectable to 75 Ω or 93 Ω).

OTHER CHARACTERISTICS

Remote Control — All operating modes can be controlled by applying appropriate TTL LO True signals to the appropriate control line at the interconnect board. These modes are Erase, View, Copy, Write-Thru, Non-Store, Brite, Defocus, Center and G Busy.

Status Signals — Output signals provided to indicate status of display are D Busy and SLU. The HCU status signal is available when an appropriate hard copy device is connected.

CHARACTERISTICS

| Horizontal Format | 0° tilt | | -15° tilt | |
|-------------------|---------|------|-----------|------|
| | mm | in | mm | in |
| Height | 461 | 18.2 | 450 | 17.7 |
| Width | 487 | 19.2 | 487 | 19.2 |
| Depth | 705 | 27.8 | 660 | 26.0 |
| Vertical Format | 0° tilt | | -15° tilt | |
| | mm | in | mm | in |
| Height | 563 | 22.2 | 547 | 21.5 |
| Width | 425 | 16.8 | 425 | 16.8 |
| Depth | 705 | 27.8 | 660 | 26.0 |

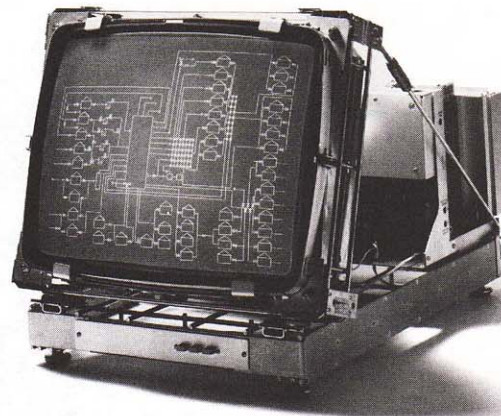

GMA 101A/GMA 102A

Both the GMA 101A and GMA 102A are 483 mm (19 in) diagonal modular graphic and alphanumeric storage displays. The GMA101A is a storage-only display. The GMA102A is a higher performance instrument that also has refresh capability. Both are configured for optimum modularity, with printed circuit board modules arranged on a unique high-strength wireform chassis. This construction not only supports different performance, interface and packaging options, but permits easy removal of modules for field service.

The GMA 101A — high resolution storage.

The GMA 101A makes the benefits of low cost, high resolution storage technology graphics available to the OEM system builder in a modular display. This family member is tailored for an application that emphasizes storage graphics. You can use our options or yours to take advantage of the very fast stored data-drawing capability of the GMA101A — 100 m (3900 inches) per second. At this drawing rate, the entire screen can be redrawn in less than one second, permitting effective zooming or panning. In addition, data or picture editing can proceed with minimal thought-process interruption. You can achieve high density interactive graphics while freeing your computer to address the application rather than drive the display.

The GMA 102A — storage and refresh.

With the GMA 102A, you can display up to 40 vector meters (1575 vector inches) (30 Hz refresh rate) of refresh data while simultaneously having all of the benefits of storage technology. The storage mode presents high resolution, high density graphics at low cost, while the refresh feature adds the benefits of selective erase, interactivity and dynamic motion with the same high resolution of storage. By placing fixed or finalized data in store while retaining dynamic or working data in refresh, you can achieve high density, interactive graphics while making maximum use of your computer to address the application task rather than support the display.

Operation — both instruments. All display functions are completely programmable and designed to interface to TTL logic. They are Write-Thru (GMA 102A only), Non-Store, Brite, Defocus, Center, Copy, Erase, View and G Busy.

Options Addressed to the OEM. Both instruments in the standard display format are driven as X-Y directed beam displays using analog inputs. Both have clear glass filters and are compatible with Tektronix hardcopy units. On either, the display can be supplied with the CRT module tilted as far back as 15° or oriented in either the horizontal or vertical (page) format. Space has been left in the card cage for you to add up to three circuit boards with your application options. Additionally, on the GMA 102A, our Option 42 Vector Generator or Option 43 Vector/Character Generator can be plugged into two of these positions to give you a completely digital interface (16 bit word format plus control and status signals).

On both instruments, you can use your interface connector or ask for our Option 34 (analog) or Option 35 (digital) connector as appropriate.

GMA 125

The GMA 125 was designed exclusively for systems builders, and is intended to satisfy display applications of the greatest size and complexity. It incorporates 65 percent more workspace than even our own previous industry leaders, the 483 mm (19 in) GMA 101A and GMA 102A. Like other members of the GMA series, it provides low cost, high resolution, storage tube graphics and unique flexibility of performance, interfacing and packaging.

Further, the GMA 125 offers that same powerful combination of simultaneous storage and re-freshed displays that was first provided in the GMA 102A.

The detail of storage. The dynamics of re-fresh. The GMA 125 features a 635 mm (25 in) CRT that offers unequalled information display capacity. Adjacent points that would be indistinguishable on a smaller screen can be seen as distinct units on the GMA 125. It is ideal for group viewing and for greater graphics detail. A new 110° CRT provides greater display brightness with less energy consumption in a more compact package.

The GMA 125 will display up to 50 vector meters (1968 vector inches) of refreshed data, enabling all the benefits of selective erase, interactivity and dynamic motion with the same high resolution of storage.

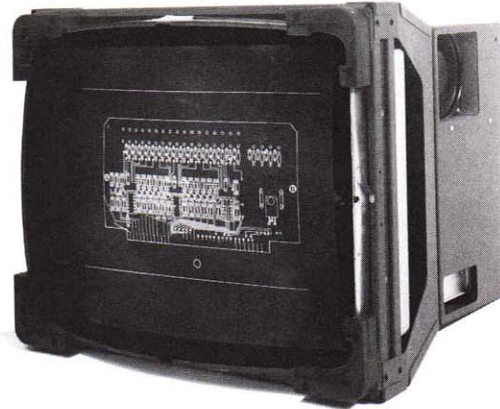

By placing fixed or finalized data in store while retaining dynamic or working data in refresh, you can work interactively with high density graphics and alphanumeric while making maximum use of processing power to address the application rather than support the display.

Modular design assures ideal building economy. Order CRT, chassis and power supply only, or configure your GMA 125 to best fit your own manufacturing capabilities and system specifications. The welded-steel, symmetrically structured chassis may be rotated vertically or horizontally, and tilted. Space is left in the card cage for your own application options. Or you can plug in our Option 42 Vector Generator or Option 43 Vector/Character Generator to provide you with a

completely digital interface (16 bit word format plus control and status signals). You can use your interface connector or our analog or digital interface options.

Colored light filters and several other support options are also available.

Operation. The standard display instrument is driven as an X-Y directed beam display using analog inputs. The CRT beam is positioned at center screen with zero volts applied. All other display functions are completely programmable and designed to interface to TTL logic. The display functions are Write-Thru, Non-Store, Brite, Defocus, Center, Copy, Erase, View and G Busy. The Z-axis input is a digital signal.

4633A

Line Scan Recorder

Black on White or Gray Scale

Excellent Copy Quality

100 mm/s Paper Speed

The Tektronix 4633A Continuous Recorder is designed to provide hard copy output from systems that provide a Z-axis input signal simultaneously with an X-axis (horizontal ramp) signal. It is uniquely suited to the requirements of the medical echocardiography market and can also be modified to suit other applications where there is a need for recording real time data.

The 4633A has three basic speeds, selectable on the front panel: 10 mm/s, 25 mm/s, and 50 mm/s. Another switch allows the operator to double each of the three basic speeds. This provides a maximum speed capability of 100 mm/s and also gives the operator considerable operational flexibility.

The 4633A is available as either a rackmount or benchtop model. The rackmount version fits into any standard 19 inch rack.

The medium: high performance/low cost, dry process, full-size paper. The 4633A is designed for high performance/low cost dry silver paper: The state of the art in dry process gray scale.

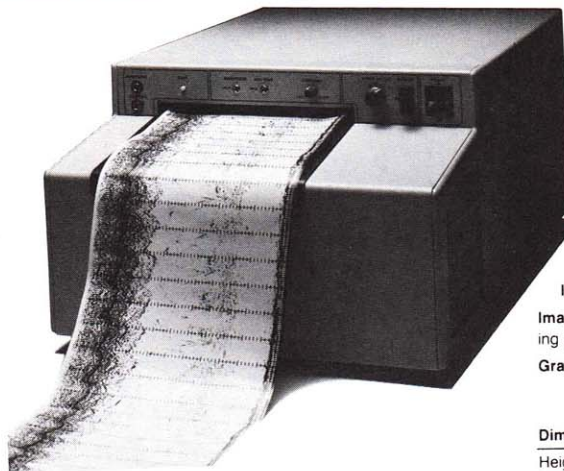

After the paper has been exposed by a fiber optic CRT, it passes through a processor, where the latent image is thermally developed. The developed image is transported by a conveyor through an opening in the front panel.

Unwanted interruptions will be minimal. Big 500-foot paper rolls mean few time-outs for reloading. The paper is a full 8 1/2 inches wide.

The 4633A's image quality, convenience, reliability, and competitive pricing combine to make it a valuable component of an OEM system.

CHARACTERISTICS

Recording Medium

Material — Dry silver paper — High performance.

Paper Roll Length — 152 m (500 ft).

Paper Roll Width — 216 mm (8.5 in).

GENERAL PERFORMANCE CHARACTERISTICS

Warmup Time — 20 min.

Image Width — 14-20 cm (5.5-7.9 in).

Image Format — Scan lines perpendicular to direction of exiting paper.

Gray Shades — 5 levels min.

PHYSICAL CHARACTERISTICS

| Dimensions | mm | in |
|------------|--------|-------|
| Height | 265.9 | 10.47 |
| Length | 655.4 | 25.80 |
| Width | 425.4 | 16.75 |
| | kg | lb |
| Weight | ≈ 30.5 | 67.0 |

4633A OPTIONS

Option 30 Delete Rackmount Hardware

INTERNATIONAL POWER CORD AND PLUG OPTIONS

Option A1 Universal Euro 220 V/16A No Charge

Option A2 UK 240 V/13A No Charge

Option A3 Australian 240 V/10A No Charge

Option A4 North American 240 V/15A No Charge

SUPPLIES

High Performance Paper — One roll, order 006-2432-00
One case, order 006-2432-01.

TEK

COMMUNICATIONS DIVISION

Providing quality products designed to test, measure and monitor television, RF, and audio electronic signals is the responsibility of Tek's Communications Division. Austin Basso, division sales manager, shown here with representative spectrum analyzer, cable tester, and television instruments, exemplifies our continuing commitment to the markets we serve. Through a cohesive network of domestic and international sales and service locations, each with personnel experienced and knowledgeable in the communications marketplace, we bring Tektronix performance and support to our customers throughout the world.

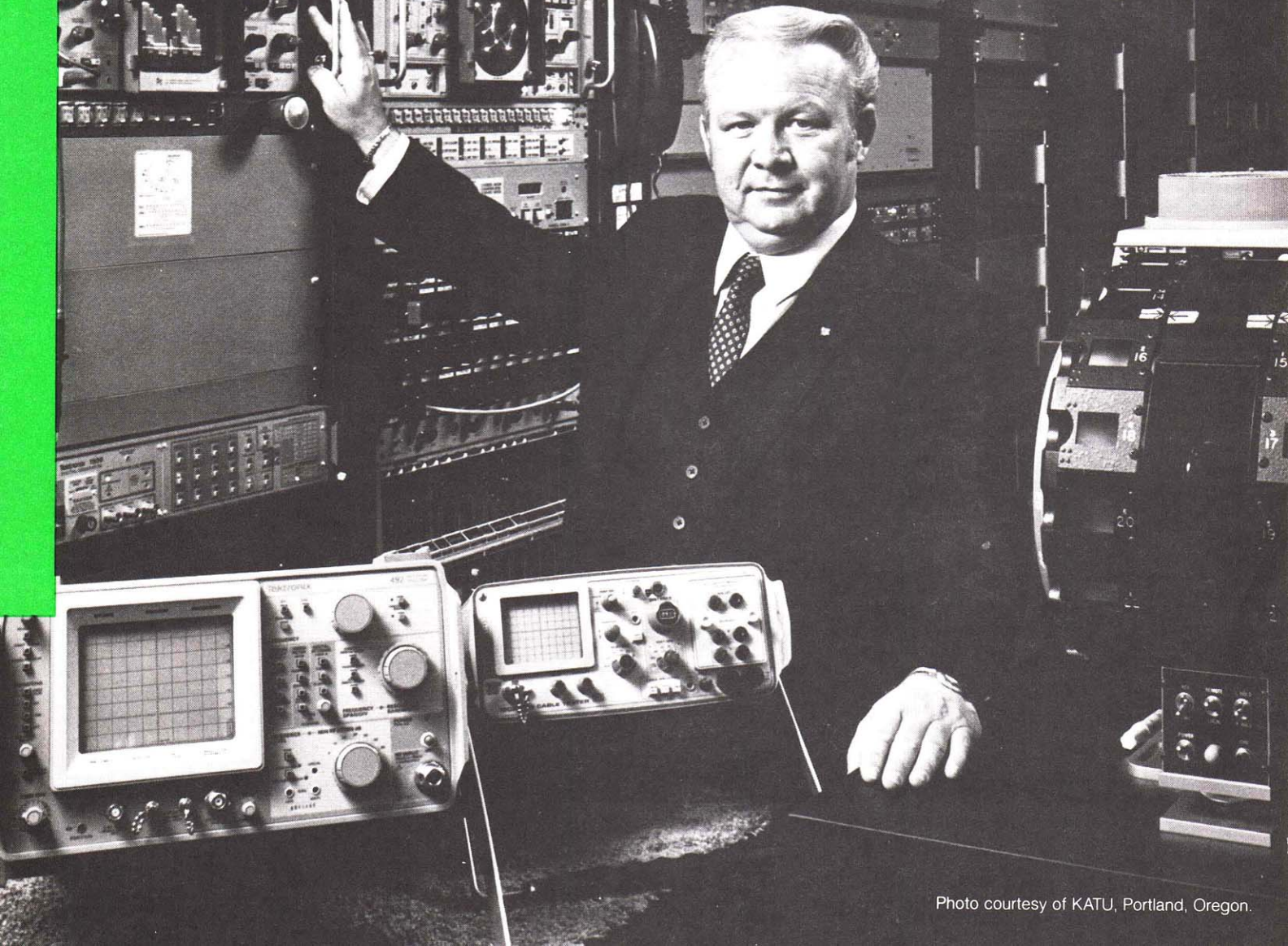
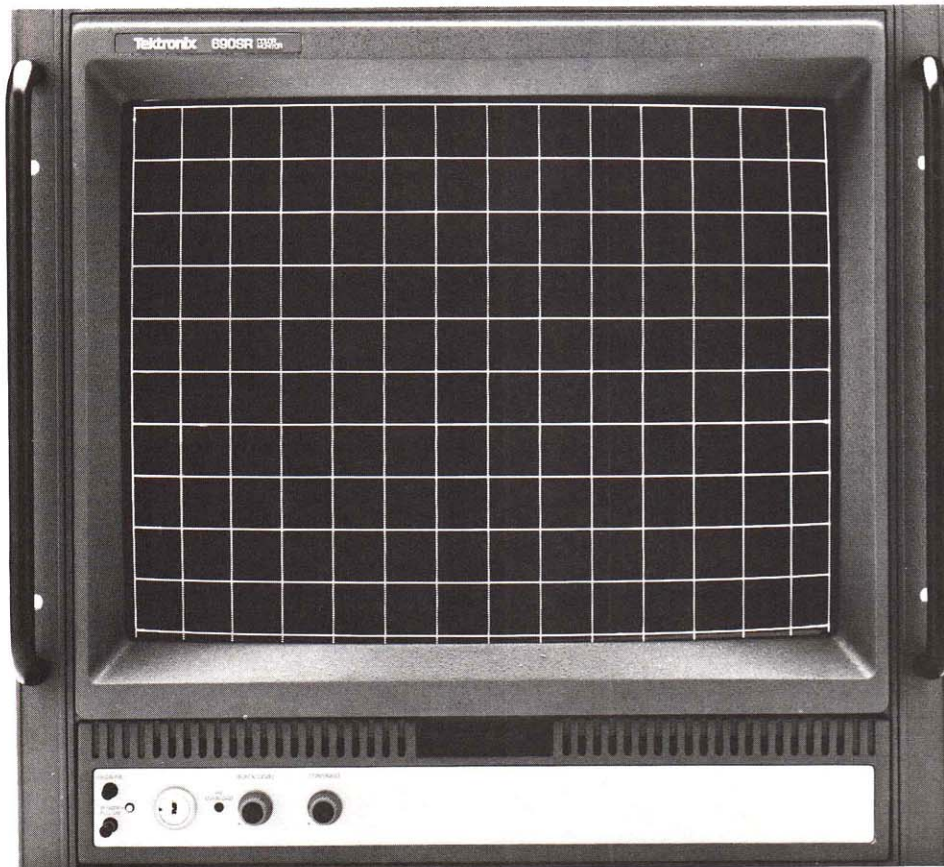

Photo courtesy of KATU, Portland, Oregon.

TELEVISION PRODUCTS

CONTENTS



690SR Picture Monitor

Color Picture Monitors

| | |
|--|-----|
| 690SR, 69M00, 69M41 | 104 |
| 650HR, 650HR-1, 651HR, 651HR-1, 653HR, 653HR-1, 655HR, 655HR-1, 656HR, 656HR-1 | 105 |

Waveform Monitors

| | |
|------------------|-----|
| 1480 | 106 |
| 528A | 107 |
| 520A | 108 |
| 1420, 1424 | 109 |

Television Demodulators

| | |
|--|-----|
| 1450-1, 1450-2, TDC, TDC-1, TDC-2 | 110 |
|--|-----|

Signal Generators

| | |
|-----------------|-----|
| 143 | 111 |
| 1410/1411 | 112 |
| 148/1470 | 113 |

| | |
|---------------------------------|-----|
| 1900 Transmitter Test Set | 114 |
|---------------------------------|-----|

| | |
|---|-----|
| 1980 ANSWER Automatic Video Management Set | 115 |
|---|-----|

The following page contains a synopsis of Tektronix Television products. For details about worldwide standards, other products, and complete descriptions, contact your nearest Tektronix office listed on pages 366-368.

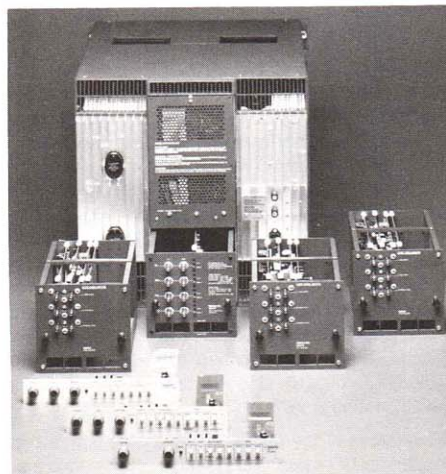

Interface Modules add versatility by helping fit the 690SR to a wide variety of user requirements. New modules will become available to keep it configurable to your needs.

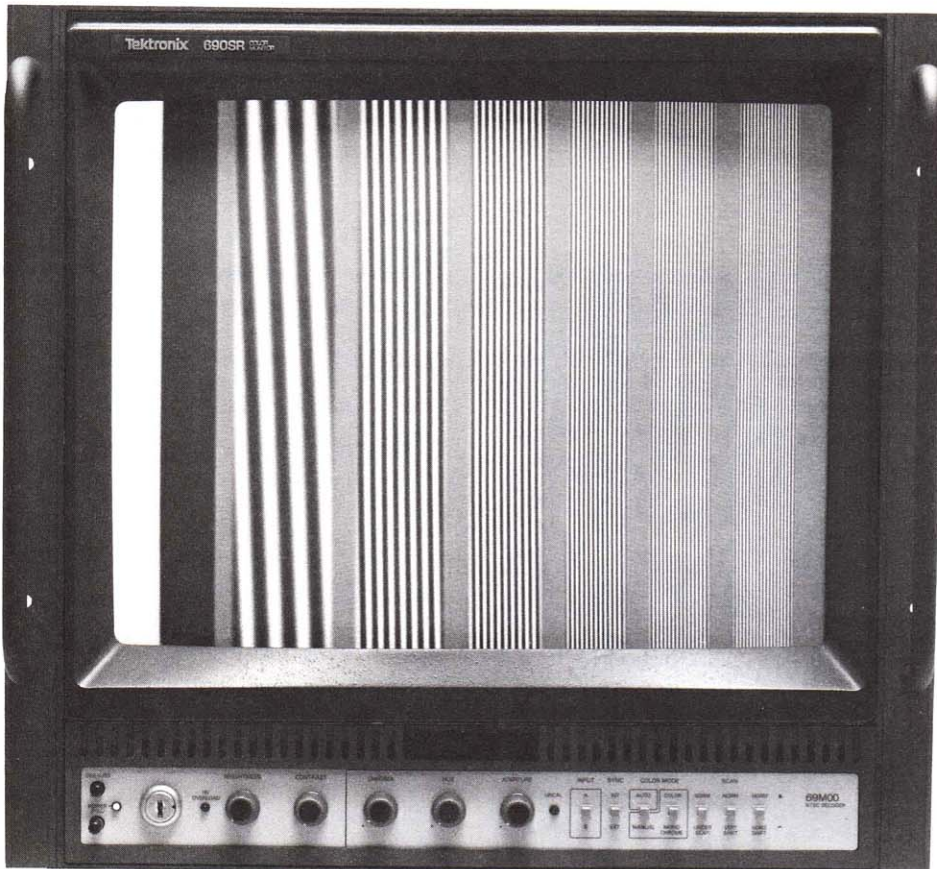

690SR Option 01

NEW

690SR Television Color Monitor

High-Resolution, Dot-Shadowmask CRT

Precise Color Convergence

Stabilized Color Balance

Rugged Construction

Preset Controls

Plug-in Decoder

Recommended for Critical Picture Evaluation

The 690SR is a new tool for the television industry to meet critical needs for picture evaluation and quality control. With a high resolution delta gun, dot shadowmask picture tube and precise, stable decoding circuitry, the 690SR offers faithful rendition of picture details and ease of closeup viewing. The optional medium resolution CRT provides uniform screen appearance and excellent resolution at greater viewing distances. With either picture tube, Tektronix unique color convergence system provides accurate color registration over the entire screen — less than 0.5 mm maximum error, equivalent to less than 0.18% of picture height — so that fine details can be observed anywhere in the picture.

Stabilized circuitry compensates for picture tube aging and maintains accurate color balance. Front panel controls for brightness, contrast, chroma, hue and aperture have detent positions so that the monitor may be returned to its preset condition quickly and accurately. Adjustments for the preset positions of front panel controls are located within a lockable front drawer together with virtually all other adjustments needed for routine servicing.

Decoders are available for NTSC and PAL standards. A flexible modular plug-in design permits the 690SR to accommodate changes in standards and additional modules will become available to meet future needs. Three systems are available at this time, comprising: the 690SR Option 01, which is an NTSC color monitor including a 69M00 notch filter decoder module installed in a 690SR mainframe; the 690SR Option 02*, which is an NTSC color monitor including a 69M01* comb or notch filter (switchable from front panel) decoder module installed in a 690SR mainframe, and; the 690SR Option 11*, which is a PAL color monitor including a 69M10* decoder module installed in a 690SR mainframe.

All versions of the 690SR are available with a high resolution CRT (standard) with 0.31 mm dot triad spacing, or with a medium resolution CRT (Option 25) which has 0.43 mm dot triad spacing. EBU phosphor colorimetry is also available (Option 27)*. All versions of the 690SR are supplied with rack slides for mounting in a 19 inch standard rack.

*Available early in 1982.

690SR Option 42
RGB Multirate Color Monitor

Scan Rates from 15 to 37.5 kHz

Adjustable Picture Size

Full Video Gray Scale

Flexible Interface

Modular Construction

High Performance for Television or
Computer Graphics

Excellent Color Convergence over Entire
Screen

The 690SR Option 42 has been designed to provide an accurate display of high quality images and computer graphics. Wide range scan circuits, excellent convergence and modular construction make the 690SR Option 42 an ideal choice for laboratory experiments and for systems where easy reconfiguration to different scan formats will make it possible for one monitor to do many jobs.

The 690SR Option 42 will operate over a horizontal scan rate range of 15 to 37.5 kHz, covering the range from standard television formats to above the 1280 by 1024 pixel format used for high resolution graphics. With the additional feature of adjustable picture size and aspect ratio, the 690SR Option 42 can be used for displays in unconventional formats. Excellent color convergence — less than 0.5 mm maximum error anywhere on the screen — is maintained over the entire rate range with only slight readjustment of controls.

The high resolution picture tube (0.31 mm dot triad spacing) is standard with all versions of the 690SR; however, a medium resolution CRT (0.43 mm spacing) is available as Option 25. Long persistence phosphors for flicker reduction in interlaced graphics displays is Option 26.

The 690SR Option 42 is an RGB monitor including a 69M41 interface module installed in a 690SR mainframe. Either internal sync on green or external sync may be used. The 690SR Option 42 is supplied with hardware for rack mounting.

ORDERING INFORMATION

| | |
|--|---------------|
| 690SR Television Color | |
| Monitor Mainframe | \$7950 |
| Option 01 NTSC Interface Installed | Add \$1100 |
| Option 25 Medium Resolution CRT | Sub \$250 |
| Option 26 Long Persistence Phosphors (High Resolution only) | Add \$150 |
| Option 42 Multirate RGB Interface Installed | Add \$2000 |
| 69M00 NTSC Decoder | |
| Interface Module | \$1100 |
| 69M41 RGB Interface Module | \$1000 |

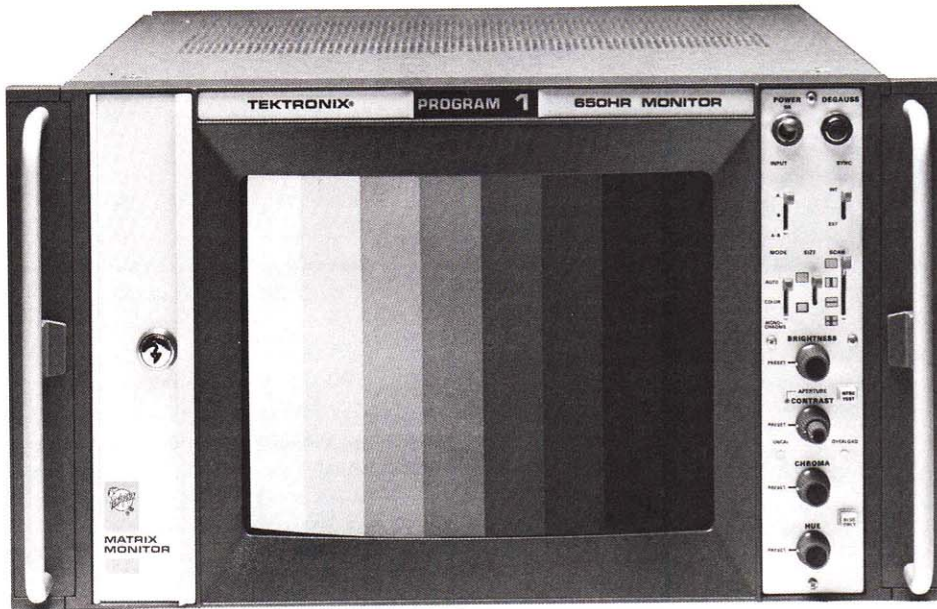

650HR Series NTSC, PAL Color Picture Monitors

Precise Color Tracking Over Full Signal Range

Two Switchable Inputs Isolated from Ground for Hum Rejection

External Sync Switching Capability

Differential (A-B) Inputs for Sync Timing and Burst Phasing Adjustments

High Resolution Trinitron CRT

Variable Aperture Correction

NTSC, PAL, and Dual Standard Versions — RGB Inputs Optional

Rapid Retrace — Entire Active Picture Area can be Displayed in Underscan

Precision Decoding — Outputs may be used to Present Vector Displays on X-Y Oscilloscopes

Unique "Blue Only" Capability for Optimizing VTR Settings

ORDERING INFORMATION

When ordering, please use the exact nomenclature given here. All 650HR Monitors are shipped with rackmounting hardware. Cabinet version hardware is also included.

| | |
|---------------------------------------|---------------|
| 650HR NTSC | \$5350 |
| 650HR-1 NTSC + RGB | \$5545 |
| 651HR PAL | \$5580 |
| 651HR-1 PAL + RGB | \$5810 |
| 655HR NTSC + PAL | \$6125 |
| 655HR-1 NTSC + PAL + RGB | \$6365 |

Accurate vector displays on X-Y oscilloscopes such as the TEKTRONIX 1424 are made possible by the precision decoder outputs on TEKTRONIX 650HR Series Monitors.

Color Picture Monitors — NTSC, PAL, SECAM, RGB

In addition to having stable, consistent color characteristics, Tektronix Color Picture Monitors provide underscan and vertical and horizontal delay for detailed examination of the entire picture. A special high resolution Trinitron CRT and adjustable aperture correction provide consistently high picture sharpness. Isolated differential inputs for encoded/composite or RGB signals, flexible synchronization and unique Blue Only mode permit the 650HR Series Monitor to meet a variety of needs — both in television systems for displaying and monitoring television picture quality and in special systems where a laboratory quality display is required.

650HR Series SECAM Color Picture Monitors

Color Sequencing from Field Identification Signals or Line Burst

Precision Decoding Allows use of R-Y, B-Y Outputs for Vector Display Measurements

PAL/SECAM Version Available (656HR) with Front Panel Selection of Decoding Standard

RGB Inputs (Optional) Includes R-Y, B-Y Output

Variable Aperture Correction

Vertical and Horizontal Delay Display Modes

Reduced Chrominance Line Crawl

Indicates Color Sequence Error

Rapid Retrace — Entire Picture Area is Displayed in Reduced Scan

Two Switchable Inputs Isolated from Ground for Hum Rejection

ORDERING INFORMATION

When ordering, please use the exact nomenclature given here.

| | |
|---|---------------|
| 653HR SECAM MONITOR | \$6355 |
| 653HR-1 SECAM + RGB | \$6570 |
| 656HR SECAM + PAL | \$6980 |
| 656HR-1 SECAM + PAL + RGB | \$7190 |
| Option 01 MiniQuick Connectors for 653HR, 656HR | Add \$130 |
| Option 01 MiniQuick Connectors for 653HR-1, 656HR-1 | Add \$195 |

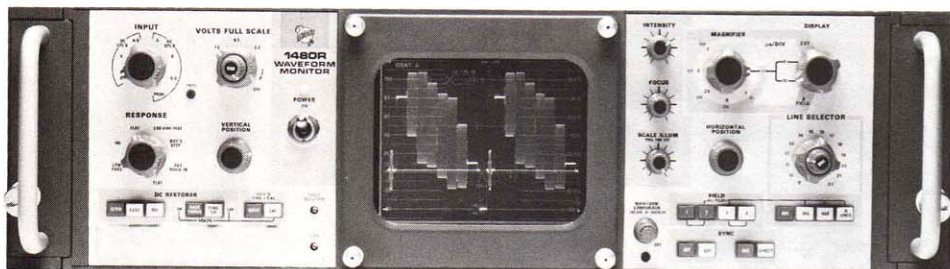

1485R Option 01 PAL/NTSC Dual Standard Waveform Monitor (Rackmount)

1480 Series

Bright CRT Especially Suitable for Vertical Interval Testing

Advanced Measurement Modes

Amplitude Measurement Accuracy Approaching 0.2%

Digital Selection of Line and Field

Probe Input Option

15 Line Display for VTR Applications

The 1480 Series of Waveform Monitors.

There are 1480 Series Monitors for PAL, PAL-M, NTSC, and SECAM. Dual standard units are also available. The differences between the monitors in the series are essentially confined to what lines in the vertical interval are selectable, what vertical amplifier response modes are available, and to the field selection modes. Dual-Standard Monitors automatically recognize the signal standard in use and indicate that standard on the front panel.

Vertical interval testing. The bright CRT of the 1480 Series eliminates many of the VITS monitoring difficulties associated with previous waveform monitors. CRT brightness is sufficient to allow you to easily see one Vertical Interval Test Signal selected out of four fields, even in a well-lighted area. This solution to VITS display problems required the design of a very high light-output CRT, which is only one of the unique features of the 1480 Series.

More accuracy, greater resolution. The 1480s provide several advanced measurement modes for more accuracy. These allow you to make amplitude measurements to an accuracy approaching 0.2%. In one mode, a precision display offset is used. A proven video measurement technique, offsetting displays with an amplitude standard is an easy-to-use method that achieves accuracy by eliminating parallax and transfer errors. Transfer errors are eliminated because the signal is compared to a precise 1 V standard rather than to graticule calibration. Measurements made with comparison techniques also are highly consistent and repeatable. When the signal precisely matches the standard, signal amplitude will be determined to the value and accuracy of the offset. The tolerance of the internal calibration signal used as the standard is 0.2%.

Sure line selection, positive field identification. Digital selection of field and line assures positive identification of displayed information. For example, selection of line 18 of field 2 assures display of line 18, field 2. Digital techniques will not allow an incorrect selection.

Response selection and a unique auxiliary mode. Many television measurements require the filtering of some components from the composite signal. For example, luminance signal rejection by 3.58 MHz or 4.43 MHz subcarrier filters for differential gain measurements. A selection of appropriate filters is provided in the 1480s, including low pass, IRE, subcarrier, and one for staircase linearity measurements called differentiated staircase. When specialized or unique measurements require a special filter, you may insert that filter between the auxiliary video output and auxiliary input. The auxiliary video input mode, selected by the response control, allows you to add a filter or other device without breaking into the program line. The auxiliary video input and output are buffered by amplifiers to provide a precise 75 Ω source and load.

In the 1480 Series, monitor focus and brightness controls compensate for changes when switching from a two field setting to a faster time base and can easily be set to an optimum level.

The fastest sweep time is 0.1 μ s per division, fast enough and bright enough to examine T pulses. The 1480s are calibrated in μ s with a basic 2% time base accuracy (3% when using the magnifier). X50 is the greatest range of magnification with steps of 10, 5, 2, and 1.

The sync recognizer has two modes: AFC and Direct. This provides a way to display jitter or to stabilize a jittery display.

ORDERING INFORMATION

When ordering, please use the exact nomenclature given here.

| | |
|--|-------------------|
| 1480C NTSC Waveform Monitor | \$4840 |
| 1480R NTSC Waveform Monitor | \$4840 |
| 1481C PAL Waveform Monitor* | \$5035 |
| 1481R PAL Waveform Monitor* | \$5035 |
| 1482C PAL-M Waveform Monitor | \$5420 |
| 1482R PAL-M Waveform Monitor | \$5420 |
| 1485C PAL/NTSC Dual Standard Waveform Monitor* | \$5325 |
| 1485R PAL/NTSC Dual Standard Waveform Monitor* | \$5325 |
| Option 01 1 MΩ, 20 pF Probe Input (probe not included) | Add \$245 |
| Suggested Probe: P6108 10X Probe. | |
| 2 m order 010-6108-03, 3 m order 010-6108-05 | \$90 |
| Option 02 With Carrying Case (Cabinet Version Only) | \$115 |
| Option 03 With Blank CRT | No Charge |
| Option 04 Tone Wheel Sync (1480C, 1481C, 1482C, and 1485C only. Replaces 529 or T04 in some RCA VTRs — Check with RCA for retrofit compatibility) | Add \$665 |
| Option 05 Tone Wheel Sync (1485C only — check with RCA for retrofit compatibility) | Add \$655 |
| Option 06 124 Ω WECO Style Inputs (1480R only) | Add \$1660 |
| Option 07 Slow Sweep.** | Add \$405 |
| Option 08 SECAM Field Identification (1481C, 1481R, 1485C and 1485R only) | Add \$275 |

*1481C/R, 1485C/R meets European Broadcast Union Tech. 3221-E, Guiding Principles for design of Television Waveform Monitors.

** Option 07 satisfies EBU Tech. 3221-E §3.2.2.

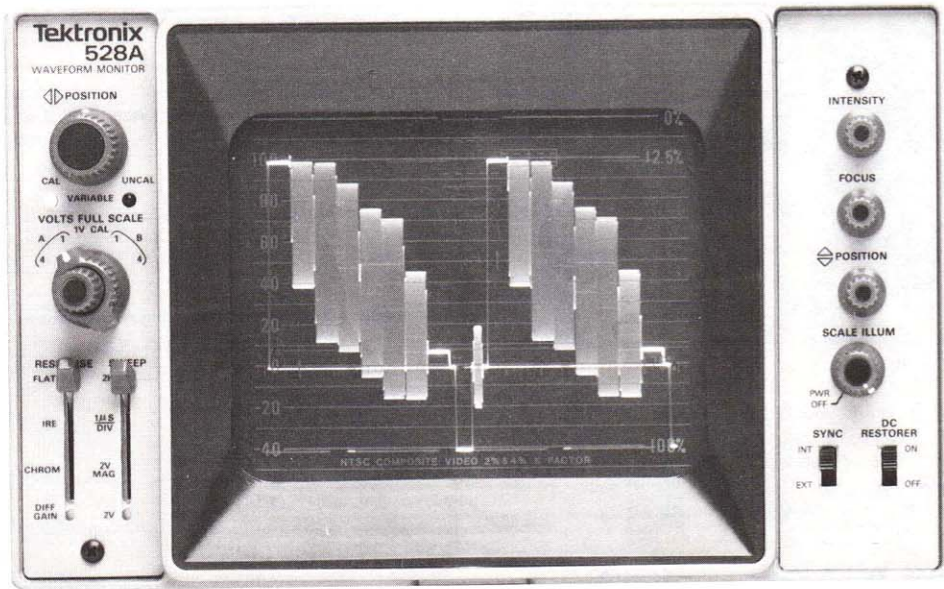

NEW

528A

Internal Graticule CRT

Ac or Dc Input Coupling

Video Output of Displayed Signal

Precise Frequency Response

Line Tilt and Pulse Response (K Factor) Measurements

Different Versions for 525 or 625 Line Systems

UL 1244 Listed and Certified to CSA 556B

The TEKTRONIX 528A Waveform Monitor is intended for television measurement and monitoring applications, adding new features and capabilities to the well known 528.

The 528A provides bright, easy-to-read waveform displays on a 125 mm (5 inch) CRT with illuminated internal graticule for parallax-free waveform monitoring and measurement while only requiring 5 1/4 inches of vertical height and 1/2 rack width mounting space. This permits mounting the 528A side-by-side with another 528A or other monitors, such as the TEKTRONIX 1420 Vectorscope. A version of the 528A in a carrying case is also available.

Selectable from the front panel, either of two 75-ohm video inputs may be displayed and the selected input is available on the rear panel VIDEO OUT connector for routing to a picture monitor or other device. These inputs are normally ac coupled, but are easily set for dc coupling.

Calibrated 1 volt and 4 volt full scale sensitivities are provided for displaying video and sync levels and a VARIABLE VOLTS FULL SCALE control permits uncalibrated displays from 0.25 volts to 4.0 volts full scale. A built-in 1 volt calibration signal may be switched on to confirm the vertical calibration.

Input signal characteristics can be isolated by using the RESPONSE switch in the FLAT position for full bandwidth display, IRE position for IEEE Standard 205 roll off display, CHROMA position for a display without luminance components, or DIFF GAIN position for displaying the differential gain error of the input signal. A dc restorer, which may be turned off when not required, maintains the back porch at an essentially constant level regardless of changes in signal amplitude, average picture level, and color burst. Selectable external sync capability is also provided.

Horizontal sweep selection includes: 2H (two line), 1 μ s (expanded two line), 2V (two fields) and 2V MAG (expanded two-field). Displays of RGB and YRGB waveforms from a color camera are provided for by using a rear panel 9-pin interface.

This compact instrument is especially suited for monitoring signals from studio camera outputs, video system inputs and outputs, production switchers, and editing consoles. The 528A allows the operator to adjust and monitor video and sync levels, check and adjust system timing, ensure continuity of the signal and perform camera alignment procedures. The 528A also meets many of the requirements of video tape recorder monitoring bridges for VTR alignment and set-up, differential gain measurements, line time tilt measurements, and pulse response (K factor) measurements. In general, the 528A is well-suited for all television applications where consistent video quality monitoring is a requirement.

ORDERING INFORMATION

When ordering, please use the exact nomenclature given here.

| | |
|--|---------------|
| 528A Waveform Monitor (for 525 line) | \$2175 |
| Option 01 Without cover | Sub \$30 |
| Option 02 With blue protective carrying cabinet .. | Add \$65 |
| Option 03 Modified for use with 625 line (CCIR) television systems and wired for use with 230 volt ac 50 Hertz power sources (unless otherwise specified). | No Charge |

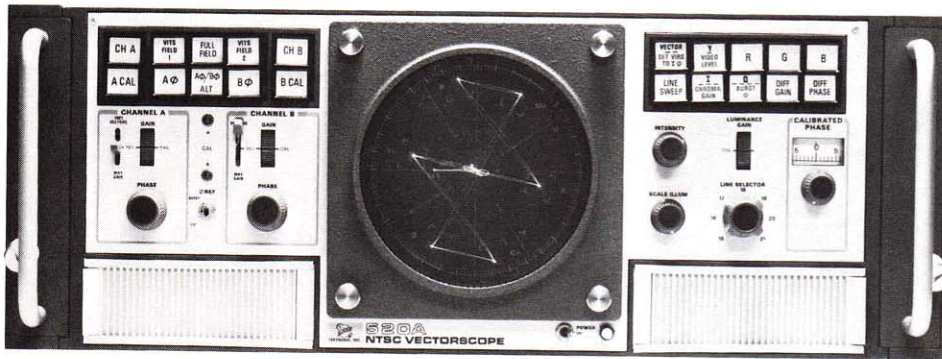

R520A NTSC (525/60 3.58 MHz) 520A (NTSC), 521A (PAL), AND 522A (PAL-M) VECTORSCOPES

520A Series

Luminance Amplitude

Chrominance Amplitude and Phase

Differential Phase

Differential Gain

The vector display shows the relative phase and amplitude of the chrominance signal on polar coordinates. To help identify these coordinates, the graticule has points corresponding to the proper phase and amplitude of the primary and complementary colors: R(Red), B(Blue), G(Green), Cy (Cyan), Y_L (Yellow), and M_G (Magenta).

Any errors in the color encoding, video-tape recording, or transmission processes which change these phase and/or amplitude relationships cause color errors in the television picture. Polar coordinate displays, such as those obtained on the 520A, 521A, and 522A CRT, have proved to be the best method for showing these errors.

The polar display permits measurement of hue in terms of relative phase of the chrominance signal with respect to the color burst. Amplitude is expressed in terms of the displacement from center (radial length) toward the color point which corresponds to 75% (or 100%) amplitude of the particular color being measured.

The outer boxes around the color points correspond to phase and amplitude error limits ($\pm 10^\circ$, $\pm 20\%$). For the 520A (NTSC) the inner boxes indicate $\pm 2.5^\circ$ and 2.5 IRE units, of optimum per EIA specification RS-189A. For the 521A (PAL) and 522A (PAL-M), the inner boxes indicate $\pm 3^\circ$ phase angle and $\pm 5\%$ amplitude.

An internally generated test circle, used with the vector graticule, verifies quadrature accuracy, horizontal to vertical gain balance, and gain calibration for chrominance signal amplitude measurements. Two methods of measuring phase

shifts are provided. You can accurately read large phase shifts from the parallax-free vector graticule. A precision calibrated phase shifter with a range of 30° , spread over 30 inches of dial length, is provided for measuring small phase shifts.

Dual Vector Displays. In dual-channel operation, successive samples of channels A and B are displayed on a time-shared basis. The switching rate is locked to horizontal sync, and switching transients are blanked. You can conveniently compare input/output signals from video equipment on channel A or B for phase and/or amplitude distortion.

Time Base Displays. The linear time base operates at the line rate. Color signals may be demodulated along any desired axis, I, Q, and R-Y (for NTSC), and U, and V (for PAL and PAL-M), and displayed at the line rate on a linear time base.

Red (R), Green (G), Blue (B), and Luminance (Y). The 520A, 521A, and 522A provide a luminance channel that permits the separation and display of the luminance (Y) component from the composite color signal. You can also combine the Y component with the output of the chrominance demodulators for R, G, and B displays at a line rate. You can make amplitude measurements of color signal components with an accuracy of 3%.

Vertical Interval Test Signal Observation. You can display vertical Interval Test Signals from front-panel selected lines of either field 1 or 2 on the 520A Vectorscope. For the 521A (PAL) and the 522A (PAL-M), you can display ITS from either fields 1 and 3 or fields 2 and 4.

Differential Gain and Differential Phase Measurements. The two main chrominance signal distortions — differential gain and differential phase — can be measured on the 520A (NTSC), 521A (PAL), and 522A (PAL-M) Vectorscopes. Differential gain is a change in color subcarrier amplitude as a function of luminance level. In the reproduced color picture, saturation will be distorted in the areas between the light and dark portions of the scene. Differential gain measurements with accuracy to better than 1% can be made.

Differential phase is a phase modulation of the chrominance signal caused by changes in the luminance signal level. The hue will vary with scene brightness in the reproduced color picture. Differential gain and differential phase occur separately or together. You can read differential phase errors from the precision calibrated phase shift control to 0.2° .

Included Accessories — Smoke-gray filter, installed (378-0581-00); power cord (161-0036-00). Rackmount: Same as cabinet but includes rackmounting hardware, and slide-out assembly.

ORDERING INFORMATION

When ordering, please use the exact nomenclature given here.

| | |
|---|---------------|
| 520A NTSC VECTORSCOPE (Cabinet) | \$6675 |
| R520A NTSC VECTORSCOPE (Rackmount) | \$6675 |
| 521A PAL VECTORSCOPE (Cabinet) | \$6940 |
| R521A PAL VECTORSCOPE (Rackmount) | \$6940 |
| 522A PAL-M VECTORSCOPE (Cabinet) | \$7470 |
| R522A PAL-M VECTORSCOPE (Rackmount) | \$7470 |

OPTIONAL ACCESSORIES

75 Ω Voltage Step-Up Termination — When used with a Tektronix Vectorscope, the 75 Ω Voltage Step-up Termination provides a X5 increase in chrominance amplitude and lets you make more accurate Differential Gain and Differential Phase measurements. Input impedance to the termination is a constant 75 Ω . Use of the termination requires a source of external sync to the vectorscope.

For use with 520A (NTSC), 522A (PAL-M) Vectorscopes:
BNC Connectors, order 011-0100-01 **\$70**

For use with the 521A Vectorscope:
BNC Connectors, order 011-0109-00 **\$85**

Single Sideband Chroma Amplitude Corrector —
Designed for use with a Tektronix Vectorscope in transmitter applications where a vestigial sideband signal is being demodulated with a detecting diode. The corrector provides a X2 increase in chrominance amplitude and passes luminance components with little or no attenuation. Input impedance is 75 Ω .

For use with 520A (NTSC), 522A (PAL-M) Vectorscope:
BNC Connectors, order 011-0107-01 **\$70**

For use with the 521A Vectorscope:
BNC Connectors, order 011-0108-01 **\$105**

Recommended Camera for display photographs; C-59P with Adapter 016-0295-01. See Camera section of this catalog for information.

R520A Cradle Assembly — For mounting the 520A in a WECO backless rack **order 426-0667-00** **\$33**

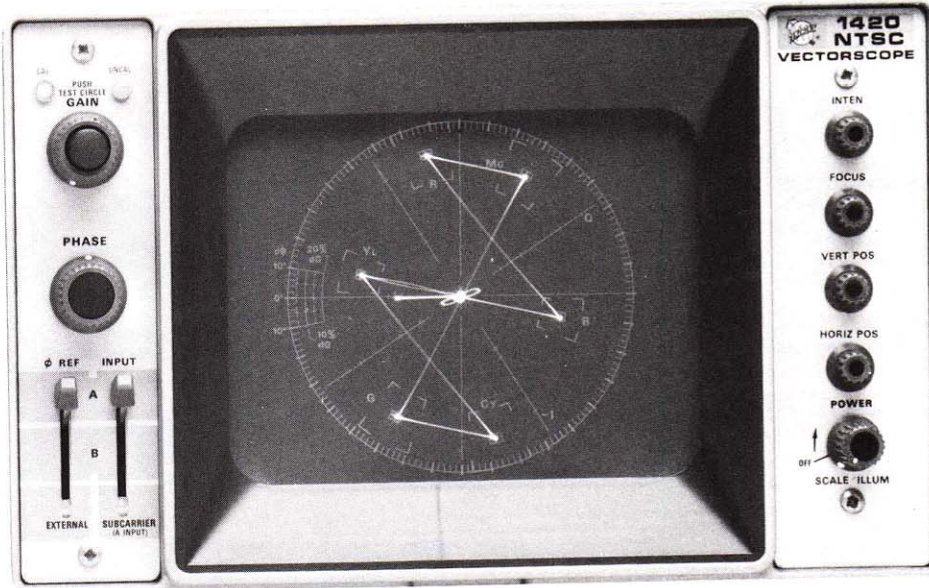

1420 Series

Half Rack Width

Two Loop-Through Inputs

Continuous 360° Phase Control

External Subcarrier Input

Illuminated Internal Graticule

X-Y Display Version

Each 1420 Series Vectorscope is a compact, half rack width instrument designed for vector display of the chrominance and burst components of the composite video signal. This series provides a low-cost way to meet basic vectorscope requirements in CCUs, VTRs, and similar applications. The 1420 is particularly well suited for side-by-side rackmounting with the TEKTRONIX 528A Waveform Monitor.

It weighs a little over 15 pounds with an optional carrying case.

The parallax-free internal graticule is designed for the vector display of color bars and burst. A special graticule feature allows you to determine gain or phase errors to reasonable accuracy for many applications—within 2° and 5% (for higher resolution differential gain and phase measurements use a 520A Series Vectorscope.)

Two signal inputs, an external subcarrier reference input, and a PAL pulse input (1421 and 1422 only) are provided on the rear panel. The "A" signal input is equipped with a switchable attenuator; use it for viewing large signals such as the subcarrier signal. Select the signal to be displayed and the locking signal for the subcarrier regenerator with two front panel lever switches. On the 1421 and 1422, a push-pull switch lets you select the external subcarrier reference signal. All models have continuous 360° phase control of the displayed signal. PAL and PAL-M displays on the 1421 and 1422 are switchable to an NTSC format.

NEW 1424 X-Y DISPLAY MONITOR

The 1424 X-Y Display Monitor provides a vector display of the chroma portion of the television signal by utilizing the decoder in a TEKTRONIX 650HR Picture Monitor or other suitable monitor. By interfacing the 1424 with the proper picture monitor vector displays for NTSC, PAL and SECAM color television systems can be obtained. Dual standard displays can be obtained by interfacing the 1424 with a TEKTRONIX 655HR (NTSC & PAL) Picture Monitor or a 656HR (SECAM & PAL) Picture Monitor.

The Z-axis input allows the writing beam to be modulated for special applications.

ORDERING INFORMATION

When ordering, please use the exact nomenclature given here.

| | |
|--|-----------|
| For NTSC, 1420 Vectorscope | |
| (Factory Wired for 115 V) | \$2700 |
| For PAL, 1421 Vectorscope | |
| (Factory Wired for 230 V) | \$2810 |
| For PAL-M, 1422 Vectorscope | |
| (Factory Wired for 115 V) | \$3050 |
| 1424 - Standard NTSC/PAL | |
| XYZ Display | \$2335 |
| Rack Adapter , (when ordering the vectorscope for use in the adapter, Option 01), 016-0115-02 | \$180 |
| Without Cabinet Option 01 | Sub \$30 |
| With Carrying Case Option 02 | Add \$65 |
| Option 03 (1424 only) — Special NTSC/PAL* | |
| XYZ display | Add \$100 |
| Option 04 — (1424 only) External SECAM graticule, blank CRT | Add \$100 |
| Option 05 — (1424 only) Combination NTSC/PAL* | |
| Internal graticule CRT | Add \$100 |
| *For Ampex VTR's — check with Ampex for compatibility. | |

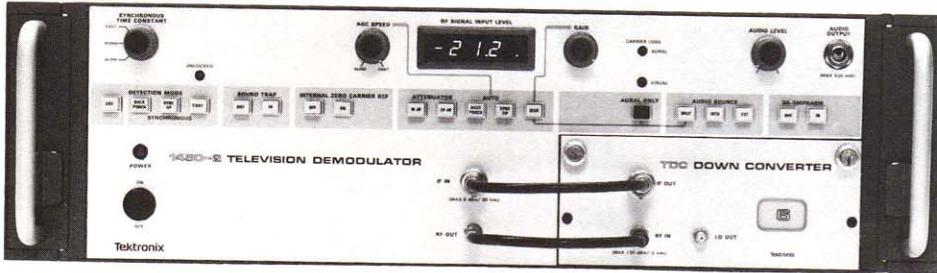

1450

Measurement Quality Performance

Precise Nyquist Slope provided by SAW Filter

Wide Dynamic Range with Constant Bandpass Characteristic

Synchronous and Envelope Detection

UHF and VHF Fixed Channel and Tunable Down Converters

Conforms to EIA Standard RS-462 (1450-1 only)

The 1450-1 (System M) and 1450-2 (System B/G) Demodulator Mainframes combine with Tektronix Television Down Converters to provide an accurate link between the transmitter's RF signal and video baseband measuring equipment. Demodulation distortion is virtually eliminated and a transparent picture of the transmitter output is provided.

Tunable or Fixed-Channel Down Converters.

For demodulating an RF signal at a TV channel frequency, the 1450-1 (M) and 1450-2 (B/G) Demodulator Mainframes must be used with a Tektronix Television Down Converter (TDC). Three compatible TDCs are available for each system and provide a selection between tunable and fixed-channel performance. The TDC Fixed-Channel Down Converter supports a specified system channel number. Tunable Down Converters available for System M VHF and UHF channels are the TDC1 and TDC2 respectively.

Demodulation of the transmitter IF signal may be accomplished by using only the mainframe.

Detection Modes. The 1450 Series Demodulators provide both synchronous and envelope detection.

Synchronous detection is required to eliminate quadrature distortion so that the transmitter's actual performance may be determined. 1450 Series Demodulators have two synchronous detector's operating in phase quadrature.

This feature is provided to assist in the measurement of transmitter incidental carrier phase modulation (ICPM). A special ICPM graticule for the 1480 Waveform Monitor is provided with each 1450 Series Demodulator. An application note on ICPM measurement is available from Tektronix.

Envelope detection is required to accurately measure differential phase. The envelope detector in 1450 Series Demodulators has a linear transfer characteristic down to 3% carrier and is able to provide optimum modulation depth indication.

Tektronix-Developed Surface Acoustic Wave Filter.

The 1450-1 (System M) and 1450-2 (System B/G) features a surface acoustic wave (SAW) filter developed by Tektronix. It provides more precise Nyquist slope characteristics without group delay distortion, improves long- and short-term stability, and lowers maintenance costs.

Digital Readout of RF Input Signal Level.

The 1450 Series Demodulators include a 3-digit front panel display that provides easy readout of the RF input signal level. The readout can be used for calibrated field strength measurements and is useful in determining how the demodulator signal-to-noise ratio is affected by RF input signal levels.

Split and Intercarrier Sound. For making measurements or adjustments on aural transmitters, the 1450-1 and 1450-2 feature both split and intercarrier sound channels. The split carrier channel, which will operate without the presence of the visual carrier, may be used when making measurements on the aural transmitter only.

Four audio outputs give added measurement capability: a 600 Ω output, two low-impedance outputs for driving a speaker or headphones, and a calibrated output for making deviation measurements with an ac voltmeter or an oscilloscope.

Note in figures 1 through 4 how synchronous detection eliminates the quadrature distortion errors introduced during envelope detection. True transmitter performance may now be determined.

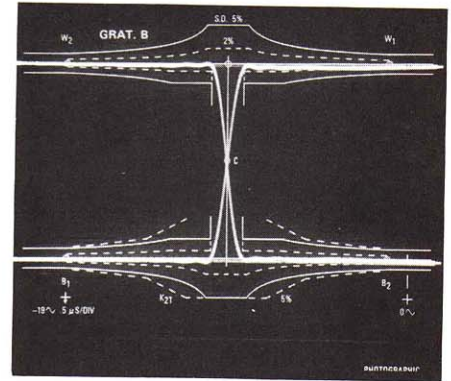

Figure 1.

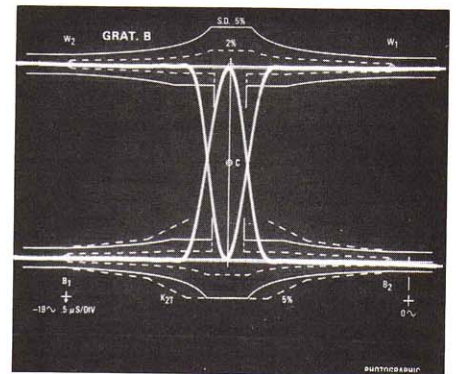

Figure 2.

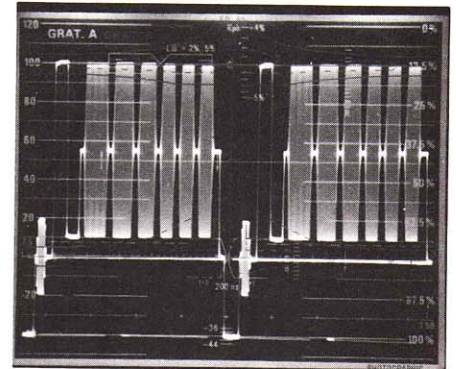

Figure 3.

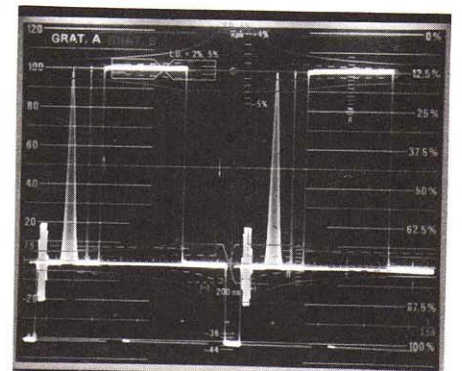

Figure 4.

ORDERING INFORMATION SYSTEM M

When ordering, please use the exact nomenclature given here.

1450-1 (order one vision IF option) **\$11,950**

Option 01 37 MHz vision IF No Charge

Option 02 38.9 MHz vision IF No Charge

Option 03 45.75 MHz vision IF No Charge

TDC Fixed Channel Down Converter (stipulate channel number when ordering) **\$2950**

TDC-1 Tunable Down Converter — System M, VHF Band **\$6375**

TDC-2 Tunable Down Converter — System M, UHF Band **\$6375**

Order one vision IF Option and Option 11 or 14. If your country is not listed, contact your nearest Sales Office for a quotation.

Option 01 37 MHz vision IF No Charge

Option 02 38.9 MHz vision IF No Charge

Option 03 45.75 MHz vision IF No Charge

Option 11 System M countries No Charge

Option 14 System M countries No Charge

Countries: System M (Option 11)

Antigua, Argentina, Barbados, Bermuda, Brazil, Canada, Chile, Colombia, Costa Rica, Cuba, Curacao, Dominican Republic, Ecuador, El Salvador, Guam, Guatemala, Johnston Islands, Korea, Mexico, Micronesia, Netherlands Antilles, Nicaragua, Panama, Peru, Phillipines, Puerto Rico, Samoa, St. Kitts, Surinam, Taiwan, Trinidad/Tobago, Uruguay, U.S.A., Venezuela, Virgin Islands.

Countries: System M (Option 14)

Japan and Okinawa.

ORDERING INFORMATION SYSTEM B/G

1450-2 (Order one vision IF option and one group delay option) **\$11,950**

Option 02 38.9 MHz vision IF No Charge

Option 09 +90/-170 ns group delay No Charge

TDC Fixed Channel Down Converter (stipulate channel number when ordering) **\$2950**

Order one vision IF option and Option 12. If your country is not listed, contact your nearest Sales Office for a quotation.

Option 02 38.9 MHz vision IF No Charge

Option 12 System B/G countries No Charge

Countries: System B/G (Option 12)

Algeria, Austria, Bahrain, Bangladesh, Belgium,* Brunei, Cyprus, Denmark, East Germany, Egypt, Ethiopia, Finland, Ghana, Gibraltar, Greece, Guinea, Hong Kong,* Iceland, India, Indonesia, Iran, Israel, Italy (UHF), Jordan, Kenya, Kuwait, Lebanon, Liberia, Libya, Malta, Mauritius, Netherlands, Nigeria, Norway, Oman, Pakistan, Portugal, Qatar, Rhodesia, Saudi Arabia,* Sierra Leone, Singapore, Spain, Sudan, Sweden, Switzerland, Syria, Tanzania, Tunisia, Turkey, Uganda, United Arab Emirates, West Germany, Yemen Arab Republic, Republic of Yemen, Yugoslavia, Zambia.

*System B only.

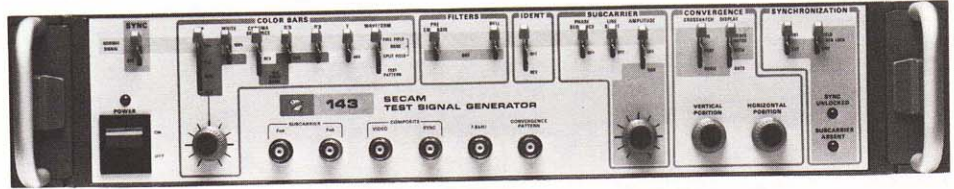

Rackmount version: cabinet version has carrying handle less mounting hardware.

143

Stand-Alone Broadcast-Quality SECAM Sync and Test Signal Generator

Will Gen-Lock to a SECAM Composite Video Signal

Composite Color Bars, Convergence Patterns, and RGB Color Bar Signals

Provisions for Modifying Test Signal Components

The TEKTRONIX 143 SECAM Test Signal Generator provides all the test and drive signals required to align and maintain SECAM television equipment. You can easily control all test signal components and synchronization modes from the front panel. Easy-to-change internal programming provides additional test signal capability to satisfy your unique testing requirements.

Test signals provided by the 143 are fully-encoded color bars, convergence pattern, and RGB color bar signals. You can select color bars in either a full-field or split-field configuration. Amplitude, white level, and chroma sequence can be changed from the front panel. You can also switch off the D'R, D'B and Y signal components individually using front panel controls.

The convergence pattern consists of movable vertical and horizontal lines plus dots. All three signals are available in any combination. A 7 x 9 or 14 x 17 crosshatch pattern may be internally selected.

RGB color bars signals are available from three separate rear-panel outputs at all times and are independent of the position of the front panel controls.

The 143 may be operated from its own internal standards or gen-locked to a SECAM composite video signal. Color lock may be referenced to either the vertical identification signals or the line burst. Front panel LEDs indicate the gen-lock status.

Additional outputs provide useful auxiliary signals including line and field drive, line and field blanking, composite sync, and two specialized output signals. These two signals are a 12.5 Hz squarewave (for identification of the SECAM 4 field sequence), and a 7.8 kHz squarewave (for synchronizing a waveform monitor to view either D'B or D'R lines only, while the 143 is generating a complete test signal). As a special convenience, the two unmodulated carrier (rest) frequencies are brought out to the front panel. It's easy to verify 143 calibration whenever routine maintenance or recalibration is performed.

ORDERING INFORMATION

When ordering please use the exact nomenclature given here:

143 SECAM Test Signal Generator
(Cabinet) **\$9450**

R143 SECAM Test Signal Generator
(Rackmount) **\$9450**

Option 01 minQUICK connectors **Add \$255**

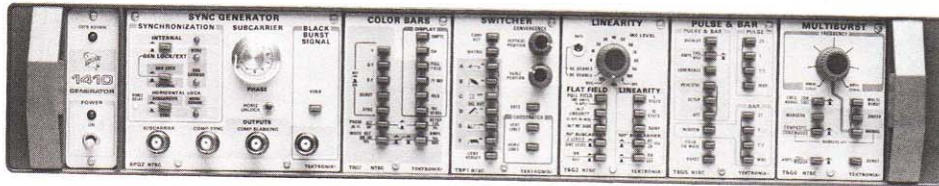

1410R Mainframe with SPG2, TSGs 7, 3, 5, 6 and TSP1 installed.

1410 Series Generators

NTSC and PAL Standards

Genlock and Non-Genlock Sync Generators

Five Test Signal Generators and One Test Signal Switcher

RS-170-A Sync Generation (1410 only)

SMPTE Color Monitor Alignment Signal (1410 only)

The 1410 NTSC and 1411 PAL Series Sync Pulse and Test Signal Generators are functionally identical within the specifications of each television system. They all offer versatile card-set construction that gives you the advantages of configurability at prices generally associated with single-piece units. With each series you have access to a wide selection of sync pulse and test signal generators that can be combined with the mainframe in the color standard of your choice. If you need additional test signal capabilities in the future, our flexible card sets assure retrofit capability for you.

Mainframes

The mainframe unit for each generator series includes the power supply, an extender board, an interface board, and color-standard circuitry. Two color-standard circuits are available for the 1410. The standard 1410 Mainframe generates chrominance subcarrier at $3.579545 \text{ MHz} \pm 10 \text{ Hz}$. An Option 01 Mainframe generates chrominance subcarrier at $3.579545 \text{ MHz} \pm 1 \text{ Hz}$. The color standard circuitry for the PAL 1411 Mainframe has a chrominance subcarrier frequency of $4.43361875 \text{ MHz} \pm 1 \text{ Hz}$.

Each $\pm 1 \text{ Hz}$ color standard has a proportional control oven for the oscillator circuit. A front-panel lamp indicates proper operation of the oven.

Sync Generators

Genlock sync generators are available for NTSC and PAL color standards. Non-genlock models are also available.

Each sync generator performs three basic functions: provides all the usual color sync generator functions and outputs including color framing. Provides the timing signals for the test signal generators installed. Provides a black burst signal.

Several useful features are incorporated in the 1410 Series sync generators. These features include:

Positive SCH Phasing. The relationship of color subcarrier to horizontal sync is strictly maintained whether operating on the generator's internal reference or in the genlock mode. If, when operating in the genlock mode, the incoming signal is not SCH phased, the generator sync and subcarrier outputs will still remain SCH phased. A color frame identification pulse output is provided.

Adjustable Blanking Widths. Internal adjustments provide for adjustment of horizontal and vertical blanking width to allow for the widening of blanking that occurs when the video signal is processed.

Slow Lock Mode. A slow genlock mode is provided for applications where the incoming video signals are not synchronous and switching the genlock input to these various signals may upset the system.

Test Signal Generators

Five test signal generators are available for the 1410 Series Mainframes. These are: Color Bars, Convergence, Linearity, Pulse and Bar, Multiburst.

The color bar generator provides full field bars, bars/Y REF, and bars/reverse bars. The TSG7 (NTSC) also includes SMPTE color bars for color monitor alignment and EIA bars. The TSG11 (PAL) also provides EBU color bars.

The convergence pattern generator provides dots, and vertical and horizontal lines. All elements of the signal are positionable. The convergence pattern conforms to IEEE Standard 202.

The linearity signal generator provides 5 and 10 step staircase, ramp, modulated pedestal, and flat field with adjustable level. Modulation level is selectable at either of two levels and, if desired, may be switched off. Average picture level (APL) of the signal is variable in fixed increments and a bouncing APL (rate adjustable) is also provided.

The pulse and bar generator provides a \sin^2 pulse, a modulated pulse, a line rate bar, a modulated bar, and a field squarewave. The shape of the \sin^2 pulse and the line bar risetime are selectable at 2T, T, or T/2. Provisions for reduced amplitude signals and setup are also included.

The multiburst generator provides the multiburst signal and a sweep frequency signal. Both signals are available in either a low or a high frequency range to facilitate testing in either an operational or a laboratory environment. Special facilities are provided for simplified amplitude measurements. For example, on the multiburst the white flag marks both the upper and lower burst excursions and the frequency packets are phase modulated. The sweep frequency signal has both amplitude and frequency markers.

The test signal switcher provides all of the functions of the convergence pattern generator plus a single, switched output of all the test signals.

ORDERING INFORMATION

| | |
|------------------------------|---------------|
| 1410C Generator | \$1540 |
| 1410R Generator | \$1540 |
| 1411C Generator | \$1980 |
| 1411R Generator | \$1980 |

Options: Consult with local Tektronix Sales Office for available options.

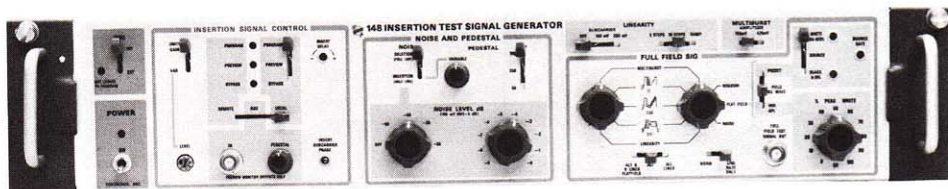

148

PAL Test Signal Generator

ITS Insertion

Full Field and In-Service Noise Measurements

The Tektronix 148 Insertion Test Signal (ITS) Generator provides all the test signals needed for testing PAL video transmission systems. Test signals are available as both full-field composite video and as ITS inserted into the incoming program signal's vertical blanking interval. All timing information for ITS insertion is derived from the incoming composite video signal.

Full field test signals provided include multiburst, linearity, flat field, window, noise, line 17, line 330 and line 331. Variable and bouncing average picture level (APL) are also provided.

Facilities are provided for the deletion and addition of insertion test signals (ITS) on the program video.

Since ITS insertion/deletion involves active circuit elements in the program line, program line fail safe operation is provided in the event of instrument malfunction, loss of sync, or power failure. A preview monitor output permits observation of the ITS deletion/insertion program before committing same to the program signal. Preview/program operation can be locally or remotely controlled.

Provisions are made for adding an externally generated ITS to the program line.

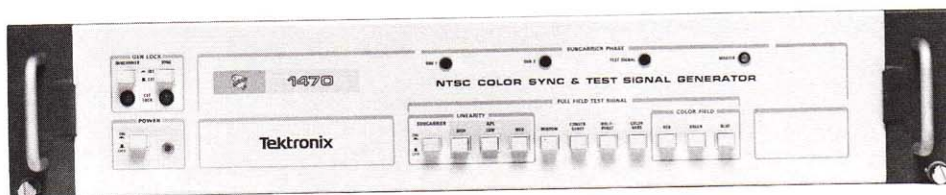

1470 Series

Full Color Sync Generator with Genlock

Locks to Most Helical Scan VTRs

Test Signal Generator

The 1470 Sync and Test Signal Generator is a compact, full color, genlock sync generator providing a full selection of high quality test signals.

The synchronizing functions of the 1470 allow for operation as a master sync generator or as a slave fully or partially timed from external sources. Color genlock capable of locking to most helical scan VTRs is a standard feature. Multiple subcarrier phasing controls are provided to simplify system timing and adjustable widths are provided on horizontal blanking and drive and vertical blanking.

Test signals included in the 1470 are color bars, linearity, multiburst, convergence pattern, window, and red, green, and blue color fields. High and low APL is provided on the linearity signal to facilitate measurements of differential gain and phase.

ORDERING INFORMATION

When ordering please use the exact nomenclature given here.

148 Test Signal Generator \$6825
R148 Test Signal Generator
 (Rackmount Model) \$6825

OPTIONAL ACCESSORIES

Noise Measurement Filters

External filters are required with the 148 Generator when making noise measurements. For systems using 625/50 standards

Low Pass 5.0 MHz 625/50
 order 015-0213-00 \$110

Noise Weighting 5.0 MHz 625/50
 order 015-0215-00 \$80

Low Pass 6.0 MHz 625/50
 order 015-0220-00 \$100

Unified Noise Weighting Network
 order 015-0283-00 \$50
 (per CCIR recommendation 568, use only with 5.0 MHz Low Pass Filter 015-0213-00).

ORDERING INFORMATION

**1470 Color Sync and Test Signal
 Generator** \$3380

Option 01, Sync Generator without Genlock Sub \$260

1474 Color Sync Generator \$1760

Option 01, Sync Generator without Genlock Sub \$260

Rack Mounting — The 1470 and 1474 are shipped ready to install.

GV3257A Automatic Change Over Unit \$1500

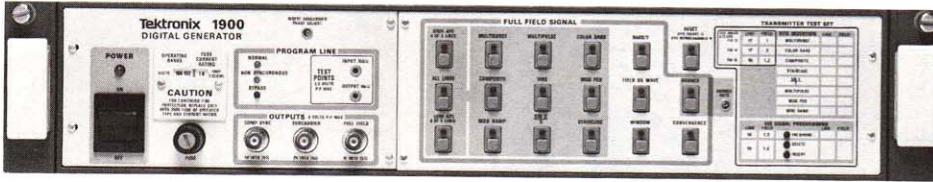

1900

10 Bit Digital NTSC Test Signal Generator

VITS Insertion

Digital Word Input and Output

Versatile Remote Control Facilities

The 1900 Digital Test Signal Generator and VITS Inserter is designed for state-of-the-art performance testing on NTSC video systems and equipment. Available in three different versions, this generator supports a wide range of transmitter, studio, common carrier, and equipment manufacturing applications. The three 1900 versions available are the Transmitter Test Set, the Studio Test Set, and the NTC 7 Test Set. Each version provides a special test signal complement, and all three offer these unique 1900 features:

10-bit digital signal generation increases test signal accuracy and long-term stability.

PROM memory allows easy signal modification when industry signal formats change.

SMPTE Color Bars, Sin x/x, and Multipulse signals facilitate the alignment of color monitors and enhance testing of frequency response and group delay. Each version of the 1900 contains one or more of these new test signals.

FCC or NTC 7 VITS and VIRS meet most testing requirements and provide a reference signal for automatic video correctors.

Digital signal output allows accurate alignment of D to A converters, while digital signal input allows alignment of A to D converters and facilitates conversion of user generated digital signals to an analog format.

RS-232-C and ground closure interfaces allow wide-ranging remote control functions and application versatility.

STANDARD ACCESSORIES

For the Cabinet and Rackmount 1900

1900 Remote Control Unit 015-0374-00; Interconnecting Cable, 1.83 m (6 ft) 012-0108-00; 1 Power Cord, 3-wire

Additional Standard Accessory for the R1900:

1 Slide Section pr drawer (351-0636-00)

ORDERING INFORMATION

When ordering, please use the exact nomenclature given here.

1900 Transmitter Test Set
(cabinet model) **\$8720**

R1900 Transmitter Test Set
(rackmount model) **\$8720**

Option 01 Studio Test Set **No Charge**

Option 02 NTC 7 Test Set **No Charge**

OPTIONAL ACCESSORIES

1900 to Remote Control Unit 6.7 m (22 ft) Interconnecting Cable **012-0251-00** **\$270**
Diagnostic PROM for instrument service **067-0964-00** .. **\$125**

1980

All-Digital Circuitry

Automatic Operation

Programmability In ANSWER BASIC

The 1980 ANSWER is an automatic measurement set offering total video test capabilities. It's programmed to make both NTC 7 and FCC measurements of all industry standard VITS and full field signals. Amplitude, phase, and timing parameters can all be determined quickly and accurately. With ANSWER you can make virtually every standard video measurement and have fast, automatic results.

ANSWER is designed for maximum versatility and testing power. The following special features give you quality measurement performance for a wide variety of applications:

Automatic Measurements Allow Quick Evaluation of VIT or Full Field Signals

NTC 7 and FCC Measurement Routines Provide Detailed Analysis of Signal Amplitude, Phase, and Timing

Simple Display Format Means Measurement Results are Easy to Read and Understand

User-Definable Measurement Limits Quickly Identify an Out-of-Tolerance Condition

Programmability Accommodates Present and Future Needs Without Additional Hardware (Answer BASIC)

Plus, RS-232-C Interface Compatibility Adapts to Almost any Application of the Broadcast Plant, an Unattended Transmitter Site, or even a Common Carrier Satellite System

High Measurement Accuracy. ANSWER provides consistent measurement accuracy with high repeatability. Special features like signal offset and gain control, dither generation, and signal averaging minimize possible errors. These techniques reduce noise on the incoming signal and provide an effective resolution of 11 bits. This means you can use ANSWER for the most stringent measurement problems and have fast, accurate results.

Automatic Operation. ANSWER is programmed with 37 individual measurements, many of which are combined into easy-to-use amplitude, phase, and timing routines. All of these operations are completely automatic and may be invoked using simple, one-word commands. You can tell ANSWER whether to run a whole measurement routine, a partial measurement routine, or a single measurement — periodically or on command. Results are ready within minutes and offer a high repeatability you can depend on.

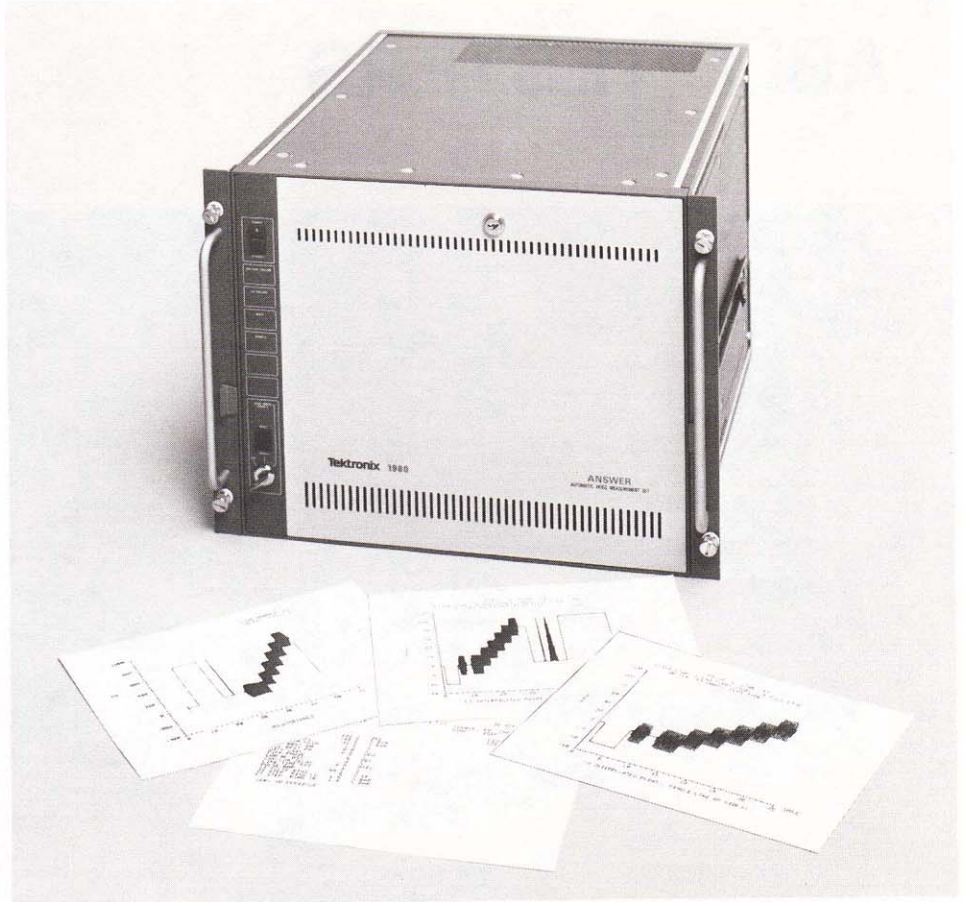

In-Service Measurements. ANSWER measures virtually all signal parameters on an in-service basis. Many of these measurements, including timing, do not even require the presence of a VIT signal. This full in-service capability minimizes the need for out-of-service measurements, so time may be spent on maintaining the system rather than on isolating system problems.

However, if the need should arise for out-of-service monitoring, ANSWER is ready with measurements for field-time, long-time, and dynamic-gain distortions.

Amplitude, Phase, and Timing. ANSWER provides a complete set of amplitude and phase measurements for both NTC 7 and FCC. These measurements include such parameters as sync, burst, and bar amplitudes; differential gain and phase; and chrominance-luminance distortions.

ANSWER also provides a complete set of timing measurements. These measurements give you detailed information on synchronizing signal parameters.

Comprehensive Display Format. ANSWER displays measurement solutions in a simple, straightforward manner. The final measurement printout indicates the types of measurement performed, the resultant data, and the units of measure. The printout heading, especially useful for documentation, tells you the exact date and time the measurements took place. At a glance, you see all pertinent parameters of the incoming video signal.

With ANSWER, you can be sure of your video transmission quality.

ORDERING INFORMATION

When ordering, please use the exact nomenclature given here.

| | |
|---|--------------------|
| 1980 ANSWER | \$20,800 |
| Option 01: NTSC Applications Software* | Add \$5,200 |
| Option 02: PAL Applications Software* | Add \$5,200 |
| Option 12: Automatic Call Equipment | Add \$500 |

*Option 01 or 02 is required.

TDR CABLE TESTERS

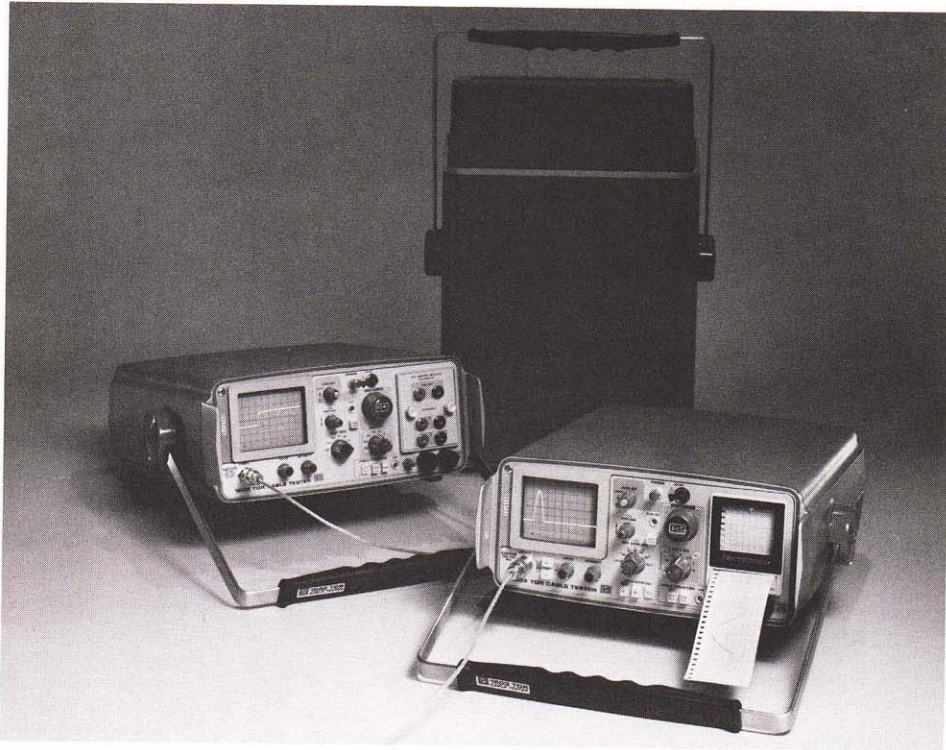

Portable —
Battery Powered, Self-Contained, Light

Rugged —
Meets MIL-T-28800, Type III, Class 3, Style A

Versatile —
Test Any Type Paired Conductor and Coax Cable

Easy to Use —
Produces Results with Minimal Operator Training

Time Domain Reflectometry *TDR

The portable, rugged 1502 and 1503 TDR Cable Testers are field maintenance tools that are simple to operate and will test any transmission cable under virtually any conditions. The 1502 is appropriate for testing coax and other cables in aircraft, ships, radar sites, etc. The 1503 tests long runs of coax or twisted pair cables in telephone and other communications applications.

These units use a technique called Time Domain Reflectometry (TDR) to identify and locate cable faults. When connected to a line in the cable, the unit sends out an electrical pulse that is reflected back to the unit by a fault in the cable. Fault type is identified by the shape of the display, and fault distance is determined by the displayed interval from the test pulse to the fault pulse.

For easy carrying and operating in tight spaces, these units are lightweight and small and will operate at least five hours on the internal, rechargeable batteries.

Since permanent records are useful in cable maintenance, an optional, plug-in chart recorder is available for paper recording of the test. The standard plug-in X-Y Output module can drive an external X-Y Recorder.

1502

This unit is directly calibrated in reflection coefficient (ρ) and distance. The 1502 uses a step-pulse and provides fault resolution to 0.6 inch on short cables. The 1502 performs to a maximum of 2000 feet, but with decreasing resolution as the fault distance increases. The unit is matched to 50-ohm cables, but may be used on others by adjusting the front panel GAIN control or using optional impedance adapters.

1503

For long cables, the 1503 provides high-energy, 1/2-sine-shaped pulses. Range of the 1503, dependent upon cable type, is up to 50,000 feet. Resolution capability provides for resolving faults as close together as three feet on short cables. Impedance levels of 50, 75, 93 and 125 ohms are selectable.

1503 Option 01

1503 Option 01 has DISTANCE CAL switches that make it more convenient for fault location in a variety of cables including coax. When the 1503 Option 01 has been calibrated for each cable before trouble occurs, and the records are kept, the DISTANCE CAL switches can be set exactly and damage location can begin immediately.

Metric instruments (1502, 1503)

For distance measurements in meters, instead of feet, there is Option 05 of both the 1502 and 1503. These instruments are fully metric versions of the 1502 and 1503 with no conversion from feet to meters involved.

The 1502 Option 05 has a distance resolution of 1.5 cm and measures 500 meters.

The 1503 Option 05 has a resolution of .9 meter and measures 10,000 meters.

PA1 Cable Comparator

The PA1 Cable Comparator is used with the 1503 to amplify the test pulse and test two lines at the same time. This means instant comparison of a bad line with a good one, the ability to see cross-talk and a clear picture of faults on noisy or lossy lines.

The PA1 is connected between the 1503 and the cable to be tested, with the results displayed on the 1503 for measurement.

*Also known as cable radar.

1502

TEST SIGNAL

Shape — Step rise.
Amplitude — 225 mV nominal (into 50 Ω load), dc coupled.
Aberrations — Within ±5% during 1st 10 ft after rise. Within ±0.5% peak beyond 10 ft NOISE FILTER "out."
System Reflected Rise — ≤0.07 ft (≤140 ps).
Jitter — ≤0.02 ft (≤40 ps) for X.1.
 ≤0.1 ft (≤200 ps) for X1.
Test Connector — BNC.
Termination — 50 Ω, within ±2%.
Max Input — DO NOT APPLY EXTERNAL VOLTAGE.

VERTICAL SYSTEM

Display Range — ±4 div.
Accuracy — Within ±3%.
Calibration Point — 2 div = 1 μ.
Deflection Factor — 5 m_p/div to 500 m_p/div, 7 steps, 1-2-5 sequence.
Variable — ≥3.5:1 from calibration point.
Displayed Noise — NOISE FILTER switch "out": ±5 m_p or less.
 NOISE FILTER switch "in": ±2 m_p or less.

HORIZONTAL SYSTEM

Distance Controls —
Distance Dial —
Range — 0 to 100 ft for X.1.
 0 to 1000 ft for X1.
Accuracy — Within ±2% of reading ±0.05 ft for X.1.
 Within ±2% of reading ±0.5 ft for X1.
Feet/div Control —
Range — 0.1 to 20 ft/div for X.1. 1 to 200 ft/div for X1.
Accuracy — Within 2% of full CRT screen.
CABLE DIELECTRIC Scales (V_p/V_{air}) — SOLID POLY, 0.66; SOLID PTFE, 0.70; OTHER VAR, 0.55 to 1.0. VAR is calibrated for air when turned fully cw.
Sweep Repetition — 40 Hz within +0 Hz, -10 Hz with NOISE FILTER switch "out." 4 Hz within ±20% with NOISE FILTER switch "in." 20 s/sweep nominal in chart recorder mode (dependent upon chart recorder).

1502 Included Accessories — Watertight front cover, TDR slide rule (003-0700-00); 50 Ω BNC terminator (011-0123-00); precision 50 Ω Cable (012-0482-00); viewing hood (016-0297-00); X-Y output module (016-0606-00); replacement fuses (for front panel) 110 V ac (159-0032-00) or 220 V ac (159-0029-01); power cord (161-0066-00); mesh filter (CRT) (378-0055-00); BNC female-to-female adapter (103-0028-00).

UNIQUE 1502 OPTION 05 CHARACTERISTICS TEST SIGNAL

Aberrations — Within ±5% during 1st 300 cm after rise. Within ±0.5% peak beyond 300 cm NOISE FILTER "out."
System Reflected Rise — ≤2.1 cm (≤140 ps).
Jitter — ≤0.6 cm (≤40 ps) for X.1.
 ≤3 cm (≤200 ps) for X1.

HORIZONTAL SYSTEM

Distance Controls —
Distance Dial —
Range — 0 to 25 m for X.1.
 0 to 250 m for X1.
Accuracy — Within ±2% of reading ±0.02 m for X.1.
 Within ±2% of reading ±0.2 m for X1.
METERS/DIV CONTROL —
Range — 0.025 to 5 m/div for X.1.
 0.25 to 50 m/div for X1.

ORDERING INFORMATION

1502 TDR Cable Tester \$5225
Option 04 (with recorder) Add \$900
Option 05 (metric version) No Charge
Option 76 (P7 Phosphor) Add \$35
 234 V International Power Cord and Plug Options A1 thru A4 available, see page 10 for full description.

1502 OPTIONAL ACCESSORIES

Chart Recorder — 016-0506-04 \$950
Chart Paper (roll) — 006-1658-01 \$6.50
Chart Paper (100 roll case) — 006-1658-02 \$490
Accessory Pouch — 016-0351-00 \$25
Impedance Adapter —
 50/75 Ω — 017-0091-00* \$95
 50/93 Ω — 017-0092-00* \$95
 50/125 Ω — 017-0090-00* \$95
 *Should be purchased with following two parts:
Connector, BNC Female-to-GR — 017-0063-00 \$43
Connector, BNC Male-to-GR — 017-0064-00 \$60

**Static Suppressor for 1502 (helps protect front end from damage) — 011-0132-00 \$29.00

1503

Shape — 1/2 sine within ±20%.
Amplitude — 10 V ±20% unterminated.
 5 V ±20%, terminated, ac coupled.
Aberrations — -30 dB p-p. (Equivalent to ±1.6%).
Duration — ≤10 ft (10 ns),*
 ≤100 ft (100 ns),*
 ≤1000 ft (1000 ns),*
 *Duration times are within ±20% at half amplitude.
Jitter — ≤1 ft for X10 (≤2 ns).
 ≤10 ft for X100 (≤20 ns).

Test Connector — BNC.
Termination — 50 Ω, 75 Ω, and 93 Ω, within 1%; 125 Ω within 3%.
Max Input — ±400 V (dc + peak ac at max frequency of 440 Hz).

VERTICAL SYSTEM

Display Range — ±4 div.
Accuracy — Within ±0.25 dB (within ±3%).
Calibration Point — 2 div = 0 dB.
Deflection Factor — 0 to 60 dB, 7 steps, 10 dB per step.
Variable — 0 to 18 dB additive to steps.
Displayed Noise — NOISE FILTER switch "out": -80 dB RMS, random.
 NOISE FILTER switch "in": -86 dB RMS, random.

HORIZONTAL SYSTEM

Distance Controls —
Distance Dial —
Range — 0 to 2,500 ft at X10
 0 to 25,000 ft at X100.
Accuracy — Within 2% of reading ±2 ft for X10.
 Within 2% of reading ±20 ft for X100.
Feet/div Control —
Range — 5 to 500 ft/div at X10. 50 to 5000 ft/div at X100.
Accuracy — Within 2% of full CRT screen.
CABLE DIELECTRIC Scales (V_p/V_{air}) — SOLID POLY, 0.66; FOAM POLY, 0.81; VAR, 0.31-1.0. VAR is calibrated for air when turned fully cw.

Distance Cal Scales, Option 01 only (V_p/V_{air}) — Selectable from 0.2 to 1.0 in 0.01 increments.

Sweep Repetition — 40 Hz within +0 Hz, -10 Hz with NOISE FILTER switch "out." 20 s/sweep nominal in chart recorder mode (dependent upon chart recorder). 4 Hz within ±20% with NOISE FILTER switch "in."
1503 Included Accessories — Watertight front cover, replacement fuses (for front panel) 110 V ac (159-0032-00) or 220 V ac (159-0029-01); power cord (161-0066-00); viewing hood (016-0297-00); 50 Ω BNC terminator (011-0123-00); X-Y output module (016-0606-00); mesh filter (CRT) (378-0055-00); 9 ft BNC-to-clip-lead cable (012-0671-02).

UNIQUE 1503 OPT 05 CHARACTERISTICS TEST SIGNAL

Duration — ≤3 m (10 ns),*
 ≤30 m (100 ns),*
 ≤300 m (1000 ns),*
 *Duration times are within ±20% at half amplitude.
Jitter — ≤0.2 m for X1 (≤2 ns).
 ≤2 m for X10 (≤20 ns).

HORIZONTAL SYSTEM

Distance Controls —
Distance Dial —
Range — 0 to 500 m at X1.
 0 to 5,000 m at X10.
Accuracy — Within 2% of reading ±0.2 m for X1.
 Within 2% of reading ±2 m for X10.
METERS/DIV CONTROL —
Range — 1 to 100 m/div at X1.
 10 to 1000 m/div at X10.

ORDERING INFORMATION

1503 TDR Cable Tester \$4550
Option 01 (Distance Cal) Add \$325
Option 04 (with recorder) Add \$900
Option 05 (metric version) No Charge
Option 76 (P7 Phosphor) Add \$35
 234 V International Power Cord and Plug Options A1 thru A4 available, see page 10 for full description.

1503 OPTIONAL ACCESSORIES

Chart Recorder — 016-0506-04 \$950
Chart Paper (roll) — 006-1658-01 \$6.50
Chart Paper (100 roll case) — 006-1658-02 \$490
Isolation Network (for balanced lines) — 013-0169-00 \$155
Adapter Cables (BNC-to-Clips) —
 9 foot — 012-0671-02 \$50
 30 foot — 012-0671-03 \$60
Accessory Pouch — 016-0351-00 \$25
Direct Current Adapter with Filter (for use with standard 12 V automobile lighter plug with negative ground)
25 foot cord — 015-0327-00 \$120

1502 & 1503 COMMON CHARACTERISTICS POWER SYSTEM

Line Voltage — 117 V ac ±20%, 48 to 410 Hz, (234 V ac ±20%, 48 to 410 Hz available with Options A1-A4).
Battery Pack —
Operation — At least 5 hr (+20°C to +25°C charge and discharge temperature) including 20 chart recordings.
Full Charge Time — 16 hr.
Typical Charge Capacity —

| Charge Temperature | Discharge Temperature | | |
|--------------------|-----------------------|----------------|-------|
| | -15°C | +20°C to +25°C | +55°C |
| 0°C | 40% | 60% | 50% |
| +20°C to +25°C | 65% | 100% | 85% |
| +40°C | 40% | 65% | 55% |

EXTERNAL RECORDER INTERFACE (STANDARD X-Y MODULE)

Horizontal — 0.1 V/div, source impedance is 10 kΩ.
Vertical — 0.09 to 0.13 V/div (adjustable), source impedance is 10 kΩ.

PHYSICAL CHARACTERISTICS

| Dimensions | cm | in |
|-----------------------------------|-----------|------------|
| Height | 12.7 | 5.0 |
| Width (with handle) | 31.5 | 12.4 |
| (without handle) | 30 | 11.8 |
| Length (handle extended) | 47.5 | 18.7 |
| (handle not extended) | 41.9 | 16.5 |
| Weight | kg | lbs |
| Net (with front cover and acces.) | 8.2 | 18 |
| (without front cover or acces.) | 7.3 | 16 |
| Domestic Shipping (complete) | 11.1 | 24.4 |
| Export Shipping (complete) | 16.3 | 36 |

PA1 Cable Comparator

Test Pulse Amplitude —
 15 V for 10 ns pulse width
 25 V for 100 ns and 1000 ns pulse widths
 Voltages ±20%
60 Hz Rejection — 40 dB.

PHYSICAL CHARACTERISTICS

| Dimensions | cm | in |
|---------------|-----------|-----------|
| Height | 15.3 | 6.00 |
| Width | 18.4 | 7.25 |
| Length | 29.2 | 11.5 |
| Weight | kg | lb |
| Net | 8.25 | 3.75 |
| Shipping | 6.75 | 14.85 |

POWER SYSTEM

Battery Powered — Requires four (4) ASA "D" size alkaline cells (not provided).
Service Life — 100 hours min.

ENVIRONMENTAL CHARACTERISTICS

Military Specification MIL-T-28800, Type II, Class 2, Style B was used as guideline for the environmental specifications.
Operating Temperature — -15°C to +5°C.
Water Resistance — Splash and drip proof. Cover removed.
Vibration — 3.0 g; 5 to 55 Hz.
Shock, Mechanical Pulse — 30 g, 1/2 sine shock.

Order PA1 Cable Comparator \$450

LOGISTICS INFORMATION

For logistics data, see Tektronix Logistics Data Book.

SPECTRUM ANALYZERS & SWEPT FREQUENCY SYSTEMS

CONTENTS

Portable Spectrum Analyzers

| | |
|----------------------------------|-----|
| 496/496P 1 kHz to 1800 MHz | 120 |
| 492/492P 50 kHz to 220 GHz | 122 |
| Waveguide Mixers | 125 |

Plug-In Spectrum Analyzers

| | |
|--------------------------------|-----|
| 7L14 10 kHz to 1800 MHz | 126 |
| 7L18 1.5 GHz to 60 GHz | 127 |
| 7L5 20 Hz to 5 MHz | 128 |
| 7L12 100 kHz to 1800 MHz | 130 |
| 5L4N 20 Hz to 100 kHz | 131 |

Tracking Generators

| | |
|---------------------------------------|-----|
| TR502/TR503 100 kHz to 1800 MHz | 132 |
| 1405 Sideband Adapter | 133 |
| Accessories | 134 |

7000 Series Plug-in Versatility

Three Models Provide Digital Storage.

With the introduction of the new 7L14, there are now three members of the Tektronix family of digital storage plug-in spectrum analyzers. They provide frequency coverage from 20 Hz to 60 GHz—the 7L18 covers 1.5 to 60 GHz, the 7L14 from 10 kHz to 1800 MHz, and the 7L5 from 20 Hz to 5 MHz. Digital storage provides: flicker-free displays that are easy to interpret; averaging and peak detection; accurate waveform comparisons; and it stores for long periods to measure amplitude changes and frequency drift.

Family Characteristics that make Spectrum Analysis Easier. The 7000 Series Family of spectrum analyzer plug-ins are compatible with any Tektronix 7000 Series Oscilloscope Mainframe, including the new 7854 Oscilloscope Mainframe for micro-processor-based processing of spectra to aid in complex measurements. Spectra and data can be transferred via the 7854's GPIB interface. These spectrum analyzers provide unequalled flexibility and versatility. With a 7000 Series Mainframe on your bench, you select the spectrum analyzers that fit your requirements. And they interchange quickly with each other and with 30 other Tektronix test and measurement plug-ins.

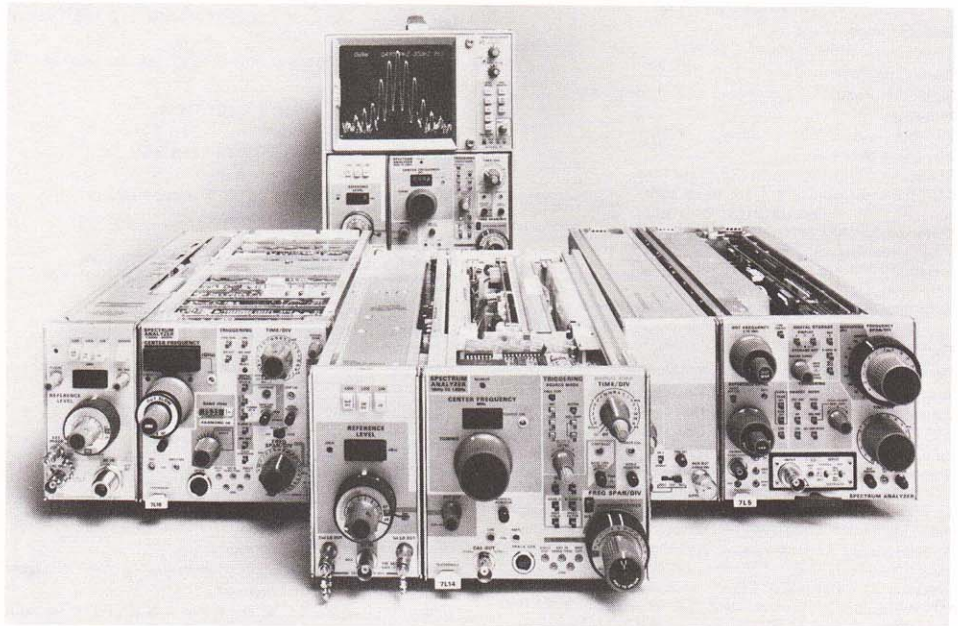

These spectrum analyzer plug-ins display alphanumeric readout for referencing and easy documentation. And each analyzer can withstand up to one watt input levels to save expensive front end repairs caused by inadvertent overloading.

Other Plug-in Spectrum Analyzers from Tektronix. The popular, economical 7L12 has capabilities similar to the 7L14 at a lower price. It is somewhat lower in performance and does not have digital storage. Front-end protection is available as an accessory.

5000 Series Mainframe owners can also add spectrum analyzer capability in the 20 Hz to 100 kHz range with the 5L4N Plug-in. This analyzer is ideal for audio, distortion and noise measurements.

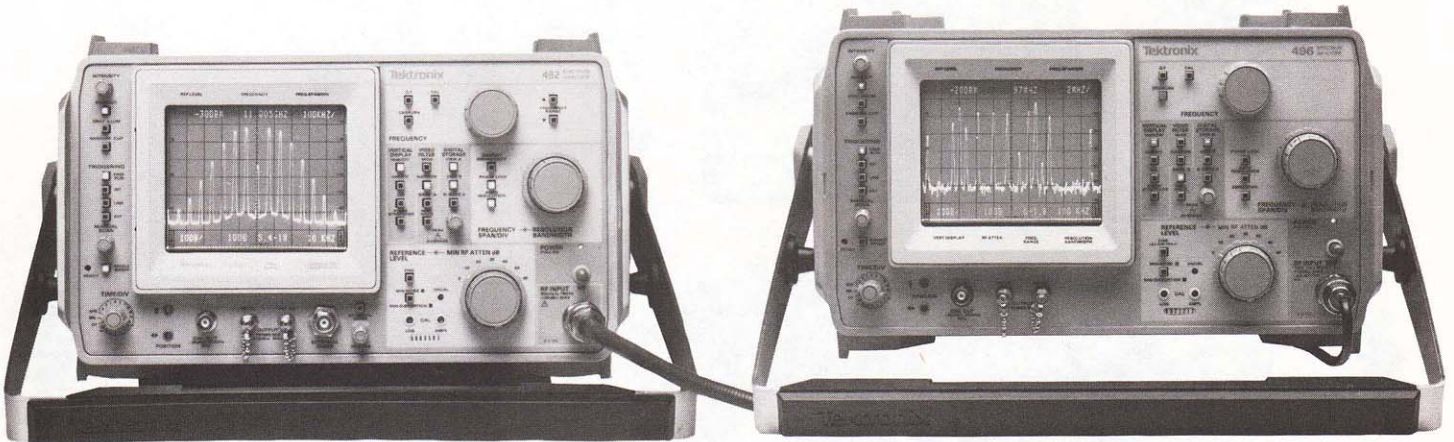

Performance for the Lab that goes into the Field

The TEKTRONIX 492 and 496 are two spectrum analyzers that go where you go. Their compact size, light weight, and rugged design combine to offer unmatched portability in laboratory quality analyzers.

Single-handle carry and portable form factor make them ready to travel. The 492 and 496 move as easily in the field as in the design lab or systems test area. They even fit under an airplane seat.

You can count on the same exceptional performance no matter where you're working. If its antenna test measurements, point-to-point transmission maintenance, or any number of critical field applications, the 492 and 496 work with you.

For on site applications reduced warmup time means reduced measurement time. Long term frequency drift of 5 kHz/10 minute after 30 minutes warmup is typical for the 492/492P and 2 kHz/10 minute is typical for the 496/496P.

Here's Proof of Their Performance

The TEKTRONIX 492 has the widest amplitude calibrated frequency range of any spectrum analyzer on the market: 50 kHz to 220 GHz using external waveguide mixers above 21 GHz. The VHF/UHF 496 covers from 1 kHz to 1.8 GHz.

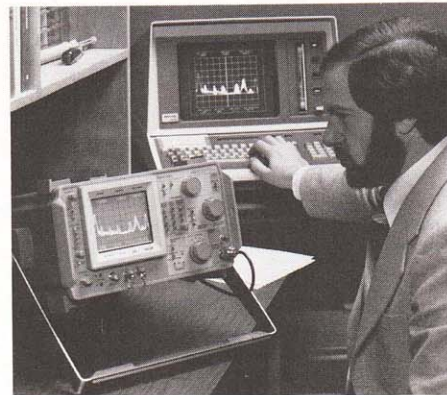

They offer 80 dB dynamic range on-screen and excellent sensitivity, with an average noise level of -123 dBm at 100 Hz resolution bandwidth for the 492, -127 dBm at 30 Hz resolution bandwidth for the 496. Low phase noise -70 dBc at only 3 kHz offset—for accurate small-signal analysis. High stability for single source spectral purity analysis, with residual FM of no more than 50 Hz peak-to-peak for the 492, 10 Hz peak-to-peak for the 496. For precise measurement of signal differences, there's amplitude comparison in super-fine 0.25 dB steps. And the 496 provides 1 kHz frequency resolution in ΔF mode. All this and more in one compact package that goes where you go.

Easy to Use - Anywhere

Tektronix designed the 492 and 496 to handle your measurement task with micro-processor-aided ease. Setting frequency, span and reference level is a simple three-knob operation. Most-used functions are automatically controlled. Digital storage and signal processing eliminate time-consuming display adjustments. And constant tuning rate helps you position a signal quickly and accurately. All part of the convenience and capability the 492 and 496 deliver, on site or on the bench.

TEK 1 kHz TO 1800 MHz PORTABLE SPECTRUM ANALYZERS

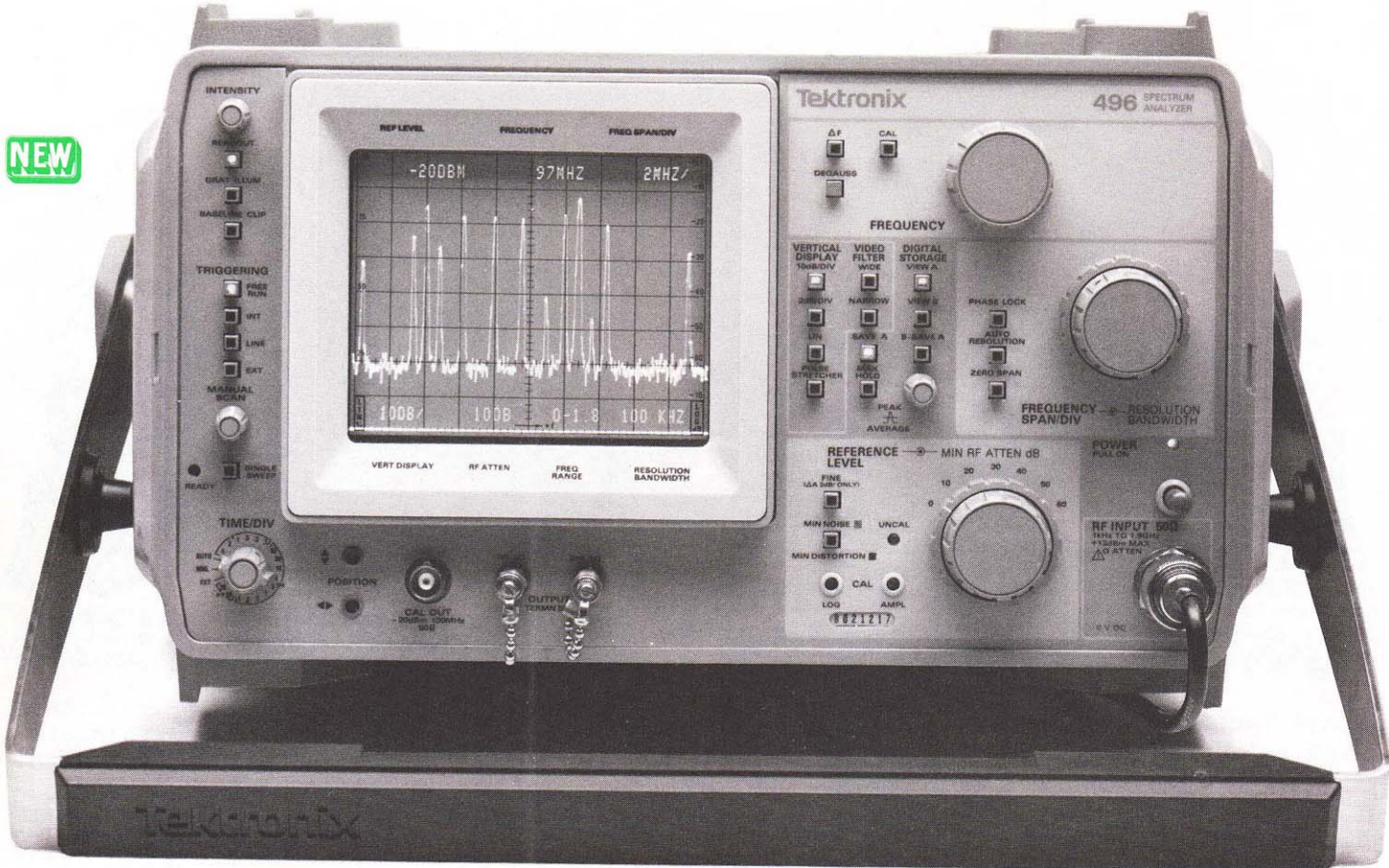

The 496P complies with IEEE Standard 488-1978, and with Tektronix *Codes and Formats* Standard.

496 **496P** **GPIB**
IEEE-488

Microprocessor Aided Controls

Automatic Modes

**Portable Form Factor
(Compact Size/Light Weight)**

1 kHz to 1800 MHz Coverage

Amplitude Comparison in 0.25 dB Steps

1 kHz Frequency Resolution in ΔF Mode

CRT Readout of all Important Parameters

Fully Calibrated in Amplitude and Frequency

80 dB Dynamic Range

GPIB/Fully Programmable (496P)

Three-knob Operation

Environmentalized per MIL-T 28800B

Digital Storage and Signal Processing

The 496 provides high performance spectrum analysis and measurements in the 1 kHz to 1.8 GHz range. Its high stability and 80 dB dynamic range meet your demands for proof-of-performance measurements, on site or on the bench.

The 496 offers state of the art performance and rugged portability. Resolution bandwidth can be varied from 1 MHz to 30 Hz over the entire frequency range. Automatic phase lock stabilization reduces incidental FM to 10 Hz p-p; phase noise sidebands are at least -75 dBc at 30 times the resolution offset. Frequency drift with phase lock is no greater than 330 Hz in ten minutes. And the 496 provides 1 kHz frequency resolution in ΔF mode.

Easy to use. Anywhere.

Simple 1,2,3 knob adjustment sets center frequency, frequency span and reference level. Power on sequence automatically normalizes operational settings and provides maximum input protection.

Digital storage eliminates time-consuming display adjustments. SAVE A, B MINUS SAVE A, MAX HOLD and AVERAGE modes let you compare, subtract, save maximum values or noise average (smooth) your spectral displays. Constant tuning rate lets you position the signal quickly and accurately at any frequency span.

Microprocessor-aided controls take care of the rest. Most-used functions are automatically controlled.

The 496 Goes Where You Go

Light weight and compact size combine to provide unmatched portability in a laboratory quality spectrum analyzer. With its single-handle carry, the 496 is easily moved around the design lab or systems test area, to the field, or wherever it may be needed.

It even fits under an airplane seat.

Automate your Spectrum Analysis with the 496P

The 496P is the fully programmable/GPIB compatible version of the 496 Spectrum Analyzer. Operation, features and benefits of the 496P are essentially the same as the 492P. See discussion on pages 123 and 124. 496 Spectrum Analyzer specifications also apply to the 496P.

Manual instruments can be converted to programmable instruments at a later time. Contact your Tektronix Sales Engineer for details.

496/496P CHARACTERISTICS

ELECTRICAL CHARACTERISTICS

The following characteristics and features apply to the 496/496P Spectrum Analyzer after a 30-minute warm up period unless otherwise noted.

FREQUENCY RELATED

- Center Frequency Range** — 1 kHz to 1800 MHz.
- Frequency Accuracy** — ± 5 MHz +20% of span/div.
- *Frequency Readout Resolution** — 1 MHz. **496P TUNE Command Accuracy (Span/div ≤ 50 kHz)** — $\pm 7\%$ or ± 100 Hz, whichever is greater.
- *Delta Frequency Readout Accuracy (Span/div ≤ 50 kHz)** — $\pm 5\%$ of the Delta Frequency Readout.
- Residual FM (short term), Phase-lock ON** — ≤ 10 Hz p-p over 20 mS.
- Residual FM (short term), Phase-lock OFF** — ≤ 1 kHz p-p over 20 mS.
- Long Term Drift** —
(At Constant Temperature and Fixed Center Frequency) —
 Phase Lock on 3.3 kHz or less in 10 Min.
 Phase Lock off 33 kHz or less in 10 Min.

Resolution Bandwidth (-6 dB) — 30 Hz, then 100 Hz to 1 MHz in decade steps, plus an AUTO position. Resolution bandwidth is within 20% of selected bandwidth.

Resolution Shape Factor (60 dB/6 dB) — 7.5:1 or less. 15:1 or less for 30 Hz Resolution Bandwidth.

Noise Sidebands — At least 75 dBc at 30 times the Resolution Bandwidth offset from the Center Frequency (70 dBc for 100 Hz Resolution Bandwidth or less).

Frequency Span/div Range — From 50 Hz/div to 100 MHz/div in a 1-2-5 sequence.

Max Span — When selected, the entire effective frequency range is scanned and displayed.

Zero Span — When selected, the horizontal axis of the CRT is calibrated in time (instead of frequency). The span/div readout is changed to time/div.

Frequency Span/div Accuracy — Within 5% of the selected span/div over the center eight divisions of the ten-division CRT display.

* ΔF mode provides incremental frequency measurements to the nearest kHz plus direct center frequency readout to the nearest kHz between 1 kHz and 1500 kHz (Phase Locked).

AMPLITUDE RELATED

Reference Level Range (full screen, top of graticule) — -123 dBm to +40 dBm (+40 dBm includes maximum safe input of +30 dBm and 10 dB of IF gain reduction) for 10 dB/div and 2 dB/div LOG modes. 20 nV/div to 2 V/div (1 W maximum safe input) in LIN mode.

Reference Level Steps — 10 dB, 1 dB, and 0.25 dB for differential (Δ) measurements in LOG mode. 1-2-5 sequence and 1 dB equivalent increments in LIN mode.

Reference Level Accuracy — Accuracy is a function of changes in rf Attenuation, Resolution Bandwidth, Display Mode and Reference Level. See amplitude accuracies of these functions. The rf attenuator steps 10 dB for reference level changes above -30 dBm (-20 dBm when Min Noise is active) unless Min rf Attenuation is greater than normal. The IF gain increases 10 dB for each 10 dB Reference Level change below -30 dBm (-20 dBm when Min Noise is active).

Display Dynamic Range — 80 dB at 10 dB/div, 16 dB at 2 dB/div, and 8 divisions in LIN mode.

Display Amplitude Accuracy — ± 1.0 dB/10 dB to a maximum cumulative error of ± 2.0 dB over the 80 dB window and ± 0.4 dB/2 dB to a maximum cumulative error of ± 1.0 dB over the 16 dB window. LIN mode is 5% of full scale.

Differential Amplitude — Delta A mode provides differential measurement in 0.25 dB increments.

Display Flatness — ± 1.5 dB, 1 kHz to 1800 MHz measured with ≥ 10 dB RF attenuation.

Sensitivity — Resolution Bandwidth Average Noise Level.

| | |
|---------|----------|
| 30 Hz | -127 dBm |
| 100 Hz | -123 dBm |
| 1 kHz | -115 dBm |
| 10 kHz | -105 dBm |
| 100 kHz | -95 dBm |
| 1 MHz | -85 dBm |

SUPRIOUS RESPONSE

Residual (no input signal, referenced to mixer input) — -100 dBm or less.

Third-Order Intermodulation Distortion (Min Distortion mode) — At least -70 dBc below any two on-screen signals within any frequency span.

Harmonic Distortion (cw signal, Min Distortion mode) — At least -60 dBc for a full-screen signal.

L. O. Emissions (reference to input mixer) — -70 dBm maximum

INPUT SIGNAL CHARACTERISTICS

- Rf Input** — Type N female connector.
- Input Impedance** — 50 Ω ; vswr 1.45 maximum with 10 dB or more rf attenuation.
- Input Level (optimum level for linear operation)** — -30 dBm referred to input mixer. Full screen not exceeded and MIN Distortion control setting.
- 1 dB Compression Point** — -18 dBm, no rf attenuation.
- Maximum Input Level** — +30 dBm (1 W) continuous (rf attenuation at 0 dB). 75 W peak (20 dB or more R. F. Attenuation) for 1 μ s or less pulse width and 0.001 maximum duty factor, Dc must never be applied to R. F. input.

OUTPUT SIGNAL CHARACTERISTICS

- Calibrator (Cal Out)** — -20 dBm ± 0.3 dB at 100 MHz ± 1.7 kHz.
- 1st and 2nd LO** — Provides access to the output of the respective local oscillators (1st LO +7.5 dBm minimum to a maximum of +15 dBm, 2nd LO -16 dBm minimum to a maximum of +15 dBm). These ports must be terminated in 50 Ω at all times.
- Vertical** — Provides 0.5 V $\pm 5\%$ of signal per division of video above and below the centerline.
- Horizontal Out** — Provides 0.5 V either side of center. Full range -2.5 V to +2.5 V $\pm 10\%$.
- Pen Lift** — TTL compatible, nominal +5 V to lift pen.
- IF Out** — Output of the 10 MHz IF. Level is ≈ -16 dBm for a full screen signal at -30 dBm input reference level. Nominal impedance 50 Ω .
- 496P Only: IEEE Std 488-1978 Port (GPIB)** — In accordance with IEEE-488 Standard.
- Probe Power** — Provides operating voltages (+5 V, +15 V, -15 V, and Ground) for active probes.

GENERAL CHARACTERISTICS

- Sweep Time** — 20 μ s/div to 5 s/div in 1-2-5 sequence (20 μ s/div in Auto).
- CRT Readout** — Displays: Reference Level, Frequency, Frequency span/div, Vertical Display, rf Attenuation, and Resolution Bandwidth.
- Input Voltage** — 90 to 132 Vac or 180 to 250 Vac, 48 to 440 Hz.
- Power** — 210 W maximum, 3.2 A, at 115 V and 60 Hz.

ORDERING INFORMATION

- 496 Spectrum Analyzer** \$22,950
- 496P Fully Programmable/GPIB Spectrum Analyzer** \$26,950

496 to 496P Conversion — Conversions made by your Tektronix Service Center. Contact your Spectrum Analyzer Sales Engineer or Service Center for details.

- Rackmount, Option 30** Add \$790
- Rackmount with all inputs through rear panel, Option 31** Add \$840
- Benchmount, Option 32** Add \$940

INTERNATIONAL POWER CORDS & PLUG OPTIONS

- Option A1 Universal Euro 220 V/16A** No Charge
- Option A2 UK 240 V/13A** No Charge
- Option A3 Australian 240 V/10A** No Charge
- Option A4 North American 240 V/15A** No Charge

PERIPHERAL PRODUCTS FOR (496P SPECTRUM ANALYZER)

- 4041 System Controller** \$4995
- 4052 Graphic Computing System Controller** \$9900
- 4611 Hard Copy Unit** \$4400
- 4631 Hard Copy Unit** \$5575
- 4662 Interactive Digital Plotter** \$4600
- 4924 Digital Cartridge Tape Drive** \$2990

OPTIONAL ACCESSORIES

- 1405 TV Sideband Analyzer** \$5000
- TR 503 Tracking Generator** \$6300
- For more information on the TR 503 see page 132.
- Hard Case (transit) (016-0658-00)** \$625
- Soft Case (016-0659-00)** \$125
- Polaroid Film Pack C-59AP** \$1165
- C-5C Camera** \$500

Note: The 496 Spectrum Analyzer system is compatible with all TEKTRONIX C-50 Series Cameras.

TEK 50 kHz to 220 GHz PORTABLE SPECTRUM ANALYZERS

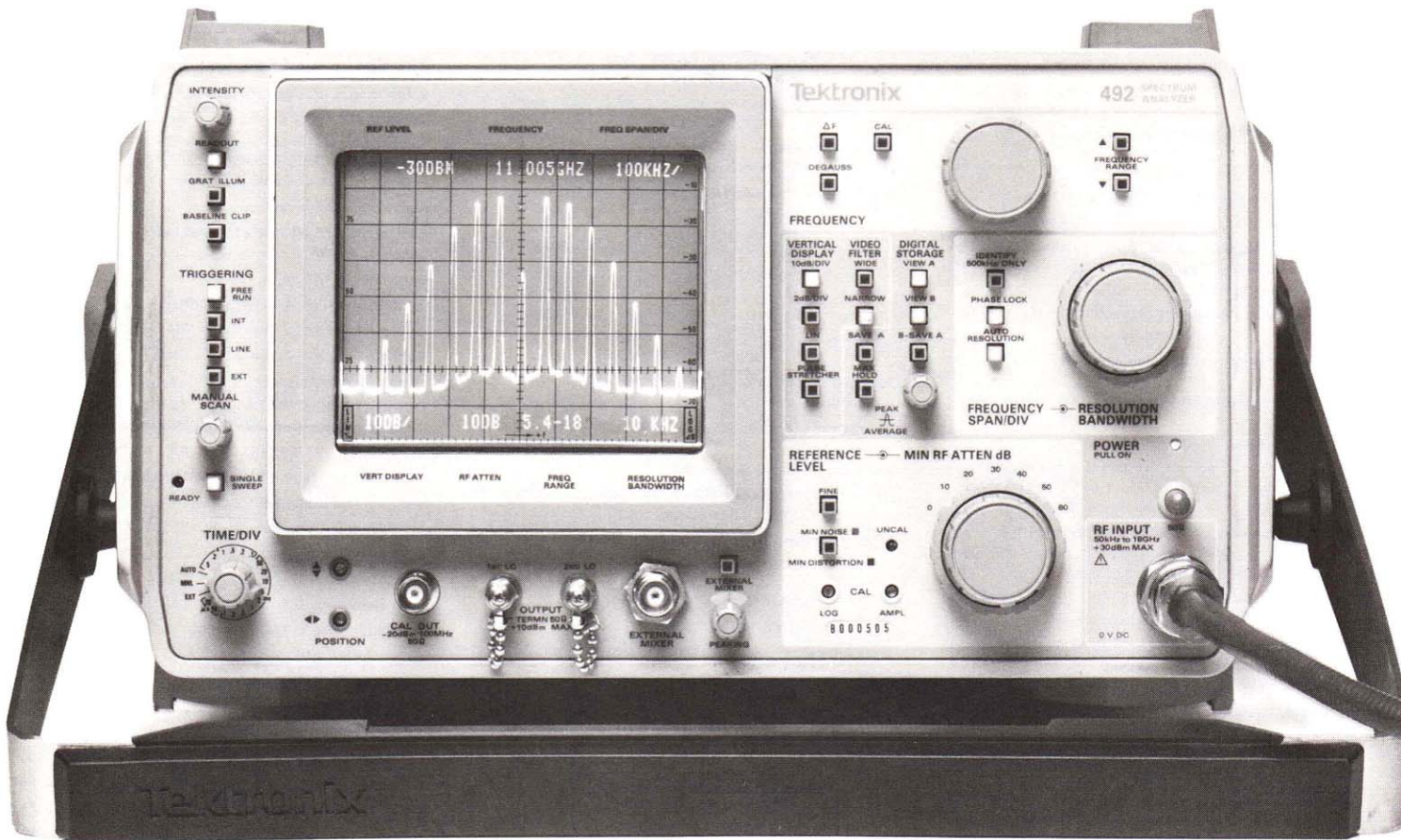

The 492P complies with IEEE Standard 488-1978, and with Tektronix Codes and Formats Standard.

492 **492P** **GPIB**
 IEEE-488

Microprocessor Aided Controls

Automatic Modes

Portable Form Factor
(Compact Size/ Light Weight)

Usable Frequency Range
From 50 kHz to 220 GHz

Amplitude Comparison in 0.25 dB Steps

CRT Readout of all Important Parameters

Fully Calibrated in Amplitude and Frequency

80 dB Dynamic Range

Wide Range of Options

GPIB Programmable (492P)

Three-knob Operation

Environmentalized per MIL-T-28800B

Digital Storage and Signal Processing

Freedom from Spurious Responses
Through Preselection

Lab Quality You Can Get a Handle on.

The 492 is a high performance, rugged, state of the art instrument of compact size, with microprocessor logic control. Full programmability via GPIB (IEEE 488-1978) compatibility is available for the 492P version.

Three-knob operation provides use as simple as 1, 2, 3 through microprocessor coupled functions such as resolution bandwidth, video bandwidth, sweep time, frequency span, rf attenuation, and reference level. Measurement accuracy is enhanced through the use of Δ dB mode, which switches in 0.25 dB steps.

Digital storage and processing facilitate trace comparisons and add measurement capability through the MAX HOLD function for frequency drift and amplitude change measurements. Arithmetic operations can be performed between traces or between a trace and a reference. Digital noise averaging mode results in trace smoothing. With digital storage, the display is steady and without flicker, even at the lowest sweep speeds; plus, trace values may be retained as long as power is on.

492P Makes Spectrum Analysis Automatic, and Easy.

Two Instruments in One.

The 492P is a fully programmable version of the 492 Spectrum Analyzer. It incorporates all of the 492's lab quality performance and ease of use features when used as a manual instrument. Push

the "Reset to Local" button and the 492P becomes a 492—with operation from the front panel. But, most important, the 492P opens the way to automated spectrum analysis and documentation via its IEEE-488 (GPIB) interface.

This versatility makes the 492P useful in many applications in the lab, factory or field.

Programmability/GPIB features can be added to manual 492 Spectrum Analyzers, serial number B03XXXX and above, and all 496 Spectrum Analyzers. This means if you want to postpone a programmability/GPIB decision because of budget constraints, or for any other reason, you can convert your 490 Series Spectrum Analyzer later. Conversions are made by your nearest Tektronix Service Center.





When used with the TEKTRONIX 4052 Graphic Computing System controller and 4631 Hard Copy Unit, or with the 4662 Digital Plotter, the 492P can provide test results in both graphic and numeric form for the evaluation of microwave signal sources.

With or Without a Controller

Switches on the rear panel select the mode of operation as a GPIB instrument. In the normal TALKER/ LISTENER mode, the 492P listens to and executes commands from a GPIB controller. All important front panel settings can be operated remotely. Some functions are controlled with more detail through the bus than possible from the front panel.

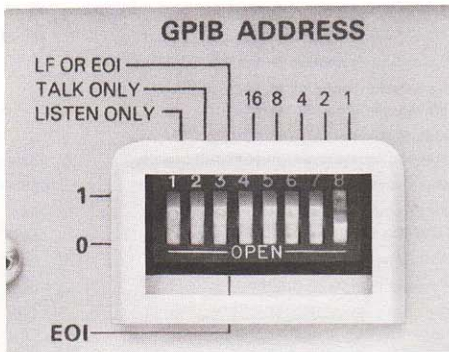

Easy to Use

The 492P is designed for ease of operation via the GPIB, just as the 492 is designed for front panel operational ease. Most commands for program control are simply abbreviations of the front panel nomenclature.

The 492P's high level command language and the similarity of commands and responses simplify programming and make program listings easily readable for editing.

Put it to Work

With the programmable 492P on your measurement team, repetitive measurements can be done the same way every time. Your throughput will increase—and your confidence in results. And, the internal processing and high level programming language makes software development faster. You get high power results with easy programming. When you look at the total performance capability of the 492P, you'll recognize its value: ease of operation both as a programmable and manual instrument. Wide frequency range. The versatility to go where you go. Into the lab for automated testing; into the field for data collection.

492/492P CHARACTERISTICS

ELECTRICAL CHARACTERISTICS

The following characteristics and features apply to the 492/492P Spectrum Analyzers after a 30 minute warmup period unless otherwise noted.

Frequency Range — 50 kHz to 21 GHz with internal mixer, to 220 GHz with external mixers. Option 08 deletes coverage above 21 GHz (calibrated mixers to 140 GHz available from Tektronix).

Frequency Accuracy — $\pm 0.2\%$ or 5 MHz whichever is greater +20% of span/div.

Frequency Readout Resolution — Within 1 MHz.

Frequency Span per Division — 10 kHz to 500 MHz plus zero and full band max span, down to 500 Hz with Option 03—in 1-2-5 sequence.

Frequency Span Accuracy — $\pm 5\%$ of span/div, measured over center eight divisions.

Resolution Bandwidth @ 6 dB Points — 1 MHz to 1 kHz (100 Hz for Option 03) in decade steps within $\pm 20\%$, manually or automatically selected.

Resolution Shape Factor (60/6 dB) — 7.5; maximum.

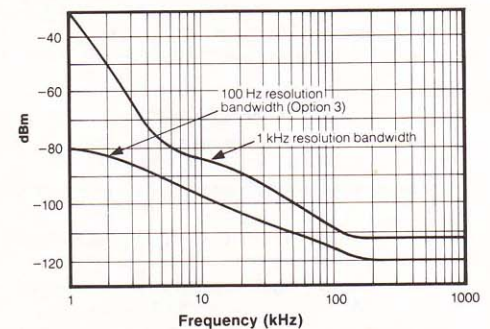

Figure 1 Typical low end frequency performance for the 492 with Option 01

SPIRIOUS RESPONSES

Residual (no input signal) — 100 dBm or less referenced to input mixer for fundamental conversion.

Harmonics — At least -60 dBc for full screen signal in the Min Distortion mode to 21 GHz. At least -100 dBc for pre-selected Option 01: 1.7 to 21 GHz.

Intermodulation — 3rd order products at least -70 dB down from two full screen signals within any frequency span in the Min Distortion mode. At least -100 dB down for two signals spaced more than 100 MHz apart from 1.7 to 21 GHz for pre-selected Option 01.

L.O. Emissions (referenced to Input mixer) — -10 dBm max; -70 dBm max for Option 01.

STABILITY

Residual FM — (1 kHz p-p) n (mixing number) for 20 ms time duration, improves to (50 Hz) n for 20 ms with phaselock Option 03.

Long Term Drift — 200 kHz/hour unphaselocked, 3 kHz/10 min phaselocked for fundamental mixing.

Noise Sidebands — At least 75 dBc @ 30X resolution offset (70 dBc for 1 kHz resolution) for fundamental mixing.

AMPLITUDE RELATED

Reference Level Range — -123 dBm to +40 dBm (+30 dBm maximum safe input) for 10 dB/div and 2 dB/div LOG modes. 20 nV/div to 2 V/div (1 W max safe input) in the LIN mode.

Reference Level Steps — 10 dB, 1 dB, and 0.25 dB for relative level (Δ) measurements in LOG mode. 1-2-5 sequence and 1 dB equivalent increments in LIN mode.

Reference Level Accuracy — Amplitude change of 0.25 dB ± 0.05 dB, 1 dB ± 0.2 dB, 10 dB ± 0.5 dB; to a maximum of ± 1.4 dB for 60 dB and ± 2 dB for 90 dB reference level change when gain change and attenuation do not offset each other.

Display Dynamic Range — 80 dB @ 10 dB/div, 16 dB @ 2 dB/div and 8 divisions linear.

Display Amplitude Accuracy — ± 1 dB/10 dB to max of ± 2 dB/80 dB; ± 0.4 dB/2 dB to max of ± 1 dB/16 dB, $\pm 5\%$ of full screen in LIN mode.

Resolution Bandwidth Gain Variation — ± 0.5 dB.

SENSITIVITY AND FREQUENCY RESPONSE

| Frequency Range | Mixing Number (n) | Average Noise Level for 1 kHz Resolution | | Frequency Response With 10 dB Attenuation | |
|-------------------|-------------------|--|---|---|-----------------------|
| | | No Preselection | Preselected Option 01 | No Preselection | Preselected Option 01 |
| 50 kHz-1.8 GHz* | 1 | -115 dBm | -110 dBm | ±2.5 dB | ±1.5 dB |
| 50 kHz-4.2 GHz* | 1 | -115 dBm | -110 dBm | ±1.5 dB | ±2.5 dB |
| 1.7-5.5 GHz | 1 | -115 dBm | -110 dBm | ±1.5 dB | ±2.5 dB |
| 3.0-7.1 GHz | 1 | -115 dBm | -110 dBm | ±1.5 dB | ±2.5 dB |
| 5.4-18 GHz | 3 | -100 dBm | -95 dBm (12 GHz) -90 dBm (18 GHz) -85 dBm | ±2.5 dB | ±3.5 dB |
| 15-21 GHz | 3 | -95 dBm | -85 dBm | ±3.5 dB | ±5.0 dB |
| 100 MHz-18 GHz*** | 3 | -95 dBm | -85 dBm | ±3.5 dB | ±4.5 dB |

With Tektronix optional high performance waveguide mixers

| | | | | | |
|---------------|----|----------|--|---------|--|
| 18-26 GHz | 6 | -100 dBm | | ±3 dB | |
| 26-40 GHz | 10 | -95 dBm | | ±3 dB | |
| 40-60 GHz | 10 | -95 dBm | | ±3 dB | |
| 60 to 90 GHz | | -85 dBm | | ±3 dB** | |
| 90 to 140 GHz | | -75 dBm | | ±3 dB** | |

*Low frequency end performance does not include effects due to zero Hz feedthrough.

**Typical over any 5 GHz bandwidth.

***Includes frequency band switching error of 1 dB maximum.

INPUT CHARACTERISTICS

Internal Mixer — Type N female connector, VSWR 1.45 to 18 GHz and 3.5 to 21 GHz; with 10 dB or more attenuation.

Optimum Level for Linear Operation — -30 dBm referenced to mixer.

1 dB Compression Point — -28 dBm from 1.7 to 2 GHz for Option 01; otherwise -10 dBm.

Maximum Safe Input Level — +13 dBm without Option 01, +30 dBm (1 W) with Option 01, zero rf attenuation.

Attenuator Power Limit — +30 dBm (1 w) continuous, 75 W peak for 1 μs or less pulse width and 0.001 maximum duty factor.

OUTPUT CHARACTERISTICS

Calibrator — -20 dBm ±0.3 dB, 100 MHz ±1.7 kHz.

1st LO — +7.5 dBm @ 50 Ω nominal +15 dBm max.

2nd LO — -16 dBm @ 50 Ω nominal +15 dBm max.

Vertical Out — 0.5 V ±5%/division, 1 kΩ nominal.

Horizontal out — 0.5 V ±10%/division, 1 kΩ nominal.

Pen Lift — TTL, 5 V nominal.

IF Out — -15 dBm nominal for full screen, -30 dBm display; 10 MHz, 50 Ω.

GPIB Control — IEEE-488 input/output control for 492P.

MISCELLANEOUS

Sweep Time — 20 μs to 5 s/div (10 s/div in auto) in 1-2-5 sequence.

CRT Readout — Reference level, center frequency, frequency range, vertical display mode, frequency span/div resolution bandwidth and rf attenuation.

CRT — 8x10 cm, P31 Phosphor.

Power — 90 to 132 Vac, 180 to 250 Vac, 48 to 440 Hz, 210 W max with all options.

Environmental Characteristics — Per MIL-T-28800B Type III, Class 3, Style C.

PHYSICAL CHARACTERISTICS

Configuration — Portable, 44 lb (all options), 6.9 x 12.9 x 19.7 in without handle or cover.

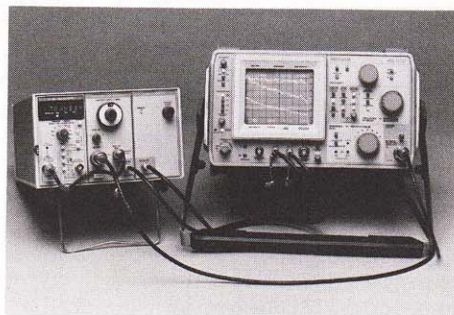

The 492 or 496 with TR503 Tracking Generator constitutes a calibrated swept frequency source covering 100 kHz to 1.8 GHz.

ORDERING INFORMATION

492 Spectrum Analyzer \$21,300
492P Spectrum Analyzer \$27,500

492 to 492P Conversion — Conversion made by your Tektronix Service Center. For 492's including Option 08 **Order 040-1038-00** **Request Quote** for 492's not including Option 08
Order 040-1037-00 **Request Quote**

Option 01 — Internal Preselection **Add \$3900**
 Provides calibrated preselected filtering of first mixer for each frequency band.

Option 02 — Digital Storage **Add \$1900**
 Provides multiple memory display storage with Save A, Max Hold, B Minus Save A, display averaging, and storage bypass.

Option 03 — Frequency Stabilization/100 Hz Resolution **Add \$3500**
 Provides first local oscillator stabilization by phase locking the oscillator to an internal reference. Also provides 100 Hz resolution.

Option 08 — Delete External Mixer Capability **Sub \$1750**
 Deletes external mixer capability which provides internal switching and connection capability to connect and use external waveguide mixers.

Option 20 — General Purpose 12.4 to 40 GHz Waveguide Mixer Set **Add \$520**
 Includes three mixers (12.4 to 18 GHz, 18 to 26.5 GHz, and 26.5 to 40 GHz) and attaching hardware to extend the upper frequency.

Option 21 — High Performance 18 to 40 GHz Waveguide Mixer Set **Add \$1970**
 Includes two mixers (18 to 26.5 GHz and 26.5 to 40 GHz) and attaching hardware to extend the upper frequency.

Option 22 — High Performance 18 to 60 GHz Waveguide Mixer Set **\$3220**
 Includes three mixers (18 to 26.5 GHz, 26.5 to 40 GHz, and 40 to 60 GHz) and attaching hardware to extend the upper frequency.

Rackmount, Option 30 **Add \$790**

Rackmount Option 31 with all inputs through rear panel **Add \$840**

Benchmount, Option 32 **Add \$940**

PERIPHERAL PRODUCTS FOR 492P SPECTRUM ANALYZER

4041 System Controller \$4995
4052 Graphic Computing System Controller \$9900
4611 Hard Copy Unit \$4400
4631 Hard Copy Unit \$5575
4662 Interactive Digital Plotter \$4800
4924 Digital Cartridge Tape Drive \$2990

INTERNATIONAL POWER CORD AND PLUG OPTIONS

Option A1 Universal Euro 220V/16A **No Charge**
Option A2 UK 240V/13A **No Charge**
Option A3 Australian 240V/10A **No Charge**
Option A4 North American 240V/15A **No Charge**

OPTIONAL ACCESSORIES

The following listed accessories are optional to all models and configurations of the 492 system, and may be ordered in any combination.

General Purpose 12.5 to 40 GHz Waveguide Mixer Set (not for Option 08)(016-0640-00) \$660
1405 TV Sideband Adapter \$5000
TR 503 Tracking Generator \$6300
For more information on the TR 503 see page 132.
High Performance 18 to 140 GHz Waveguide Mixer Set (WM 490-2) \$2010
High Performance 18 to 60 GHz Waveguide Mixer Set (WM 490-3) \$3260
Microwave Comb Generator (067-0885-00) \$1800
TV Trigger Synchronizer (015-0261-00) \$360
Hard Case (transit) (016-0658-00) \$625
Soft Case (016-0659-00) \$125
Polaroid Film Pack C-59AP \$1165

C-5C Camera \$500
 Note: The 492 Spectrum Analyzer is compatible with all TEK-TRONIX C-50 Series Cameras.

A limited quantity of the 491 is still available. Call your nearest Spectrum Analyzer Sales Engineer for information.

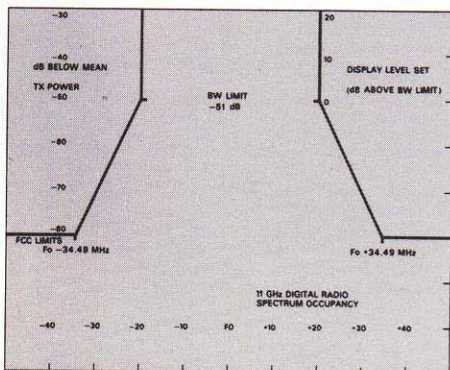
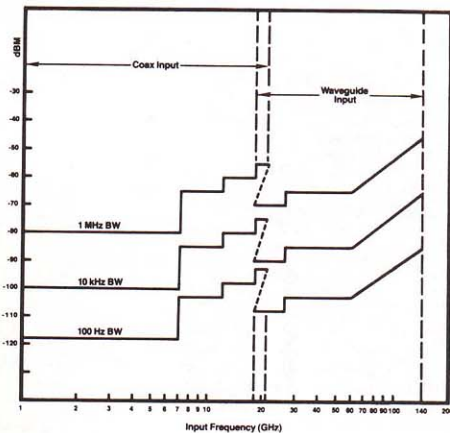

CRT mask for digital radio application. Ask about the modified 492 optimized for digital radio measurements.

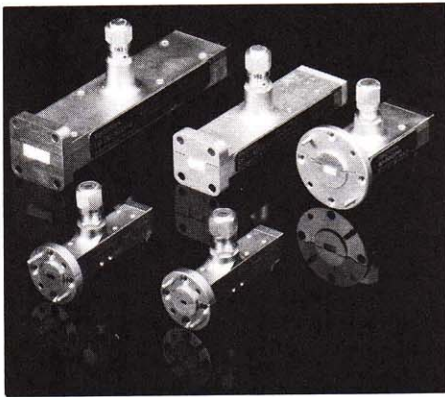

490 Series Waveguide Mixers

The 490 Series Tektronix Waveguide Mixers cover from 18 to 140 GHz with at least -75 dBm sensitivity. They are designed specifically for use with the TEKTRONIX 492 and 7L18 Spectrum Analyzers.

The two microwave mixers cover ranges 18 to 26.5 GHz and 26.8 to 40 GHz. They have field replaceable diodes and frequency response of ± 3 dB when used with the spectrum analyzers indicated above.

The three millimeter wave mixers cover ranges 40 to 60 GHz (also specified at ± 3 dB frequency response), 60 to 90 GHz and 90 to 140 GHz.

The units are all gold plated brass, conforming to MIL-G-45204 Class 1, Type 1 specifications and will withstand harsh environments. Each set comes complete with a container for spare diodes, a 28 inch cable, a 32 page instruction manual and a wood storage box with foam cutout storage locations for all five mixers.

PERFORMANCE CHARACTERISTICS

For All Waveguide Mixers — Max cw RF input level: +10 dBm (10 mW).

Maximum PULSED RF Input Level — 1 W peak with 0.001 max duty factor and 1 μ s max pulse width.

L.O. Requirement — +7 dBm min, +15 dBm max, +10 dBm typical.

Bias Requirement — -2.0 to +0.5 V with respect to the mixer body through a current limiting resistor, to provide 0 to 20 mA of bias current.

For the 18 to 60 GHz Waveguide Mixers — 3 dB compression point (saturation): -10 dBm (typical).

Conversion Loss — 30 dB typical (when used in the proper spectrum analyzer frequency band).

ORDERING INFORMATION

When ordering, please use the nomenclature given below:

| | |
|---|--------|
| 18 to 26.5 GHz: WM 490 K | \$975 |
| 26.5 to 40 GHz: WM 490 A | \$975 |
| 40 to 60 GHz: WM 490 U | \$1250 |
| 60 to 90 GHz: WM 490 E | \$2400 |
| 90 to 140 GHz: WM 490 F | \$2600 |
| 18 to 40 GHz set (items 1,2): WM 490-2 | \$2010 |
| 18 to 60 GHz set (items 1,3): WM 490-3 | \$3260 |
| 18 to 90 GHz set (items 1,4): WM 490-4 | \$5660 |
| 18 to 140 GHz set (items 1,5): WM 490-5 | \$8260 |

ELECTRICAL CHARACTERISTICS

| Frequency Range | Sensitivity ¹ (dBm) | Frequency Response ² | Amplitude Accuracy ³ |
|-----------------|--------------------------------|---------------------------------|---------------------------------|
| 18-26.5 GHz | -100 | ± 3 dB | ± 6 dB |
| 26.5-40 GHz | -95 | ± 3 dB | ± 6 dB |
| 40-60 GHz | -95 | ± 3 dB | ± 6 dB |

¹Equivalent average noise level at 1 kHz bandwidth.

²Maximum amplitude variation across each waveguide mixer band (with peaking control optimized) in response to a -30 dBm CW input signal to the waveguide mixer.

³Maximum reference level error with respect to the internal calibrator. Amplitude accuracy can be improved 3 dB by measuring amplitude responses in each band with respect to a known external waveguide signal source level.

| Frequency Range | Typical Sensitivity ⁴ (dBm) | Typical ⁵ Frequency Response | 3 dB Compression Point (Saturation) |
|-----------------|--|---|-------------------------------------|
| 60-90 GHz | -95 @ 60 GHz -85 @ 90 GHz | ± 3 dB | -15 dBm @ 60 GHz -5 dBm @ 90 GHz |
| 90-140 GHz | -85 @ 90 GHz -75 @ 140 GHz | ± 3 dB | -5 dBm @ 90 GHz 0 dBm @ 140 GHz |

⁴Equivalent average noise level at 1 kHz bandwidth. ⁵Over any 5 GHz bandwidth.

PHYSICAL CHARACTERISTICS

| Frequency Range | Length | Width | Height | Weight | Flange |
|-----------------|-------------------|---|---|----------------|------------|
| 18-26.5 GHz | 8.97 cm (3.53 in) | 2.22 cm (.875 in) | 3.68 cm (1.45 in) | 180 g (6.5 oz) | UG-595/U |
| 26.5-40 GHz | 6.93 cm (2.73 in) | 1.90 cm (.750 in) | 3.35 cm (1.32 in) | 100 g (3.7 oz) | UG-599/U |
| 40-60 GHz | 4.52 cm (1.78 in) | 1.84 cm ⁶ (.725 in) ⁶ | 2.45 cm ⁶ (.980 in) ⁶ | 80 g (2.9 oz) | UG-383/U-M |
| 60-90 GHz | 4.31 cm (1.70 in) | 0.89 cm ⁶ (.350 in) ⁶ | 2.29 cm ⁶ (.900 in) ⁶ | 40 g (1.5 oz) | UG-387/U |
| 90-140 GHz | 4.31 cm (1.70 in) | 0.89 cm ⁶ (.350 in) ⁶ | 2.29 cm ⁶ (.900 in) ⁶ | 40 g (1.5 oz) | UG-387/U-M |

⁶Excludes contribution to dimension due to the diameter of the round waveguide flange. Overall length contribution of flange is included.

Typical Frequency Response for 18-60 GHz Waveguide Mixers.

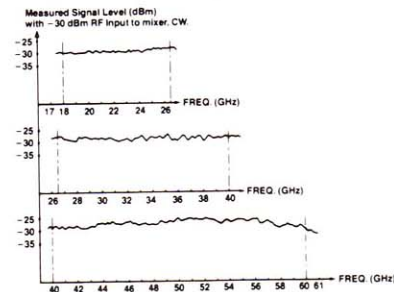

Typical Frequency Response for 60-140 GHz Waveguide Mixers.

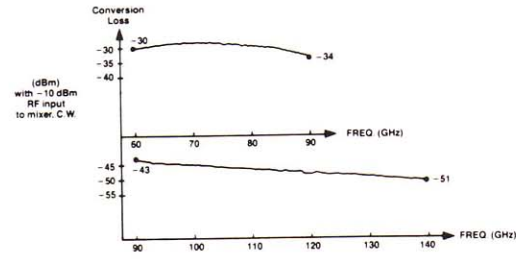

490 Series Spectrum Analyzers Rackmount/Benchmount Options

The following options denote mechanical configurations of the 492/492P/496/496P. Option 30 is a rackmount configuration for the 49X with standard front panel input/outputs. Option 31 is a rackmount configuration with rear panel input/output capability. Option 32 is a benchmount configuration that basically adds side covers and trim to an Option 30 or 31 transforming it into a stackable bench top configuration.

The Option 30 and 31 Rackmount is a standard

19 inch rack width and comes with standard rackmount fittings. A spectrum analyzer accessories storage drawer is also included. Dimensions are 22.23 x 42.9 x 63.5 cm (8.75 x 16.89 x 25.00 in). Weight is 54 lb; including the spectrum analyzer.

The Option 32 Benchmount is approximately the same size as the Rackmount but is dressed with side and top panels and carrying handles and feet. The Benchmount provides a convenient surface for stacking other instruments. Dimensions are 23.5 x 45.7 x 63.5 cm (9.25 x 17.9 x 25.00 in). Weight is 57 lb; including the spectrum analyzer.

See Ordering Information on page 121 and 124.

NEW

7L14

10 kHz to 1800 MHz Frequency Range

30 Hz to 3 MHz Resolution

4:1 Resolution Bandwidth Shape Factor

70 dB On-Screen Dynamic Range

Input Limiter Protects Mixer Up to One Watt Can be Connected to Input for Any Setting of Rf Input Attenuator

Digital Display and Signal Processing (Max Hold, Save A, Split and Comparison Features, and Algebraic Addition)

CRT Readout of all Major Parameters

Swept Frequency Measurements with TR502

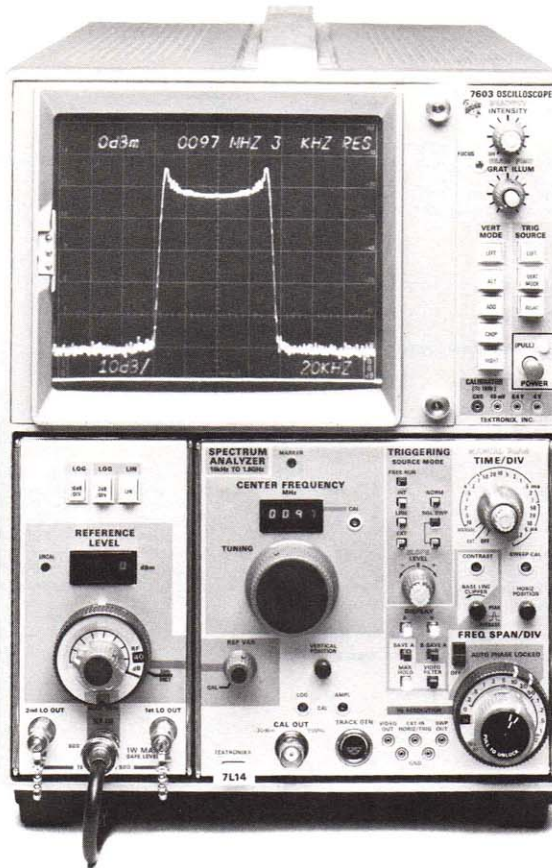

Above 100 kHz — +30 dBm to -110 dBm in 10 dB calibrated steps.

Display Flatness — ± 1.5 dB, with respect to 50 MHz, over any selected frequency span.

Sensitivity — At 50 MHz, applicable from 100 kHz to 1.8 GHz.

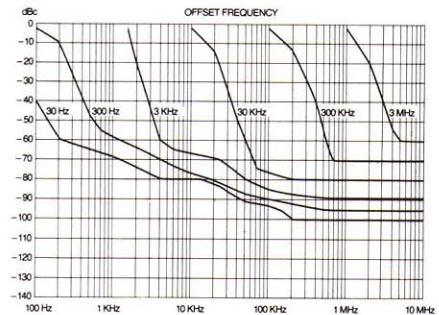

Spurious Responses —

Residual — < -100 dBm (referenced to the 1st mixer input).

Second Order Intermodulation Products — 100 kHz -1.8 GHz; down 70 dB or more from two -40 dBm signals, within any frequency span.

Third Order Intermodulation Products — 100 kHz -1.8 GHz; down 70 dB or more from two -30 dBm signals, within any frequency span.

Amplitude Characteristics —

Rf Attenuator — Calibrated in 10 dB steps.

Accuracy — ± 0.25 dB or 1.2% of dB reading; whichever is greater.

IF Gain —

Range — 70 dB (80 dB when operating in 30 Hz resolution bandwidth)

Step Accuracy — ± 1 dB per 10 dB step to ± 2 dB max over entire range.

GENERAL CHARACTERISTICS

Noise Sidebands — -70 dBc; 25 resolutions away.

Sweep — Triggered manual, external.

Sweep Time — 10 s/div to 1 μ s/div in a 1-2-5 sequence.

Accuracy — $\pm 6\%$ of selected time/div.

Triggering Modes — INT, EXT, EXT in HORIZ/TRIG and LINE.

Sensitivity — ± 0.5 div of internal signal (p-p) and/or ± 0.5 V (p-p) of ext signal.

INPUT SIGNAL CONNECTORS

Rf Input —

Maximum Input Power Level — +30 dBm.

Maximum Input Power Level to the Rf Attenuator ≥ 10 dB — 1 W average (including dc), 100 W peak simultaneously.

Input Impedance: 50 Ω ; vswr 1.35 max with 10 dB of rf attenuation.

External Horizontal/Trigger Input Connector —

Input Voltage Range — Typically 0 V to 10 V for 10 div/sweep. Typically 0.5 V (p-p) to trigger the sweep circuits. 40 V peak max.

OUTPUT SIGNAL CONNECTORS

CAL OUT — -30 dBm, ± 0.3 dB at 50 MHz, $\pm 0.01\%$.

1st LO OUT and 2nd LO OUT —

SWP OUT and Video Output —

ENVIRONMENTAL CHARACTERISTICS

The 7L14 meets its electrical characteristics over the environmental limits per MIL-T-28800 Type III, Class 6, Style E Instruments. The 7L14 is operable over the limits of a MIL-T-28800 Class 5 instrument. The 7L14 is physically and electrically compatible with all TEKTRONIX 7000 Series Mainframes.

INCLUDED ACCESSORIES

Spectrum Analyzer Graticule. Clear plastic implosion shield with LOG, LIN, REF, and f (frequency) direction markings, 337-1439-01 for 7603 Oscilloscope and 337-1159-02 for other 7000 Series Oscilloscopes. Amber Light Filter: 378-0684-01; Light Filter: 378-0625-07; 50 Ω Coaxial Cable, with BNC connectors. 6 ft: 012-0113-00; BNC Male to N Female Adapter: 103-0058-00.

ORDERING INFORMATION

7L14 Spectrum Analyzer \$16,900

7603 Display Mainframe \$2555

7613 Variable Persistence Mainframe \$4680

MAINFRAME OPTIONS

Option 06 Internal SA Graticule Add \$50

Option 08 Protective Front Cover Add \$100

Frequency Range to 2.5 GHz; ask about the 7L14 Mod 139U.

The 7L14 Plug-in Spectrum Analyzer spans the VHF/UHF frequency range with wide dynamic range and high stability to meet the demands for proof-of-performance measurements.

Resolution Bandwidth can be varied from 3 MHz to 30 Hz over the entire frequency range. This meets the requirements for displaying TV signals, radar, broadcast systems, communications equipment plus any other type of signal in the frequency range up to 1.8 GHz. Automatic phase lock ensures ease of use plus the excellent oscillator stability necessary for demanding signal measurements. Incidental FM is typically 10 Hz p-p and the phase noise sidebands are greater than -70 dBc at 25 resolution bandwidths away.

The 7L14 features digital storage which provides flicker-free, constant intensity displays regardless of sweep speed. Automatic overload protection of the first mixer in the 7L14 is provided by a built-in limiter. Signals up to one watt can be connected to the input for any setting of the rf input attenuator. The input is ac-coupled to provide protection from large amplitude (<50 V) line frequency (50/60 Hz) signals. Frequency coverage down to 1 kHz can be obtained by deleting the built-in limiter. Talk to your Tektronix Sales Engineer for details.

7L14 CHARACTERISTICS

The following characteristics and features apply to the 7L14 Spectrum Analyzer after a warm up period of 20 minutes.

FREQUENCY RELATED

Center Frequency —

Range — 10 kHz to 1.8 GHz.

Readout Resolution — Within 1 MHz.

Readout Accuracy — $\pm(5$ MHz + 20% of frequency span/div).

Frequency Span — 200 Hz/div to 100 MHz/div. In calibrated steps in a 1-2-5 sequence.

Accuracy — Within 5% of the span selected.

Linearity — Within 5% of the span selected.

Max Span — Provides 1.8 GHz of span.

Zero Span — Provides fixed frequency operation for time domain display.

Resolution Bandwidth —

Range — 30 Hz to 3 MHz, in decade steps.

Accuracy (6 dB down) — Within $\pm 20\%$ of the resolution selected.

Shape Factor (60/6 dB) — 4:1 or less for 3 MHz to 300 Hz; 12:1 or less for 30 Hz resolution.

Signal Level Change Between Any Two Bandwidths — ± 0.5 dB at room temperature. ± 2.0 dB max over temperature.

Residual FM — 13 Hz (p-p) when phaselocked ± 10 kHz (p-p) for 20 ms when not phaselocked.

Stability — At a fixed temperature after two hour warm up; ± 2 kHz/hour phaselocked; ± 75 kHz/hour not phaselocked.

AMPLITUDE RELATED

Display Modes —

Log 10 dB/div — Provides 70 dB dynamic range.

Accuracy — Within 0.15 dB/dB to 2 dB max over 70 dB dynamic range.

Log 2 dB/div — Provides 14 dB dynamic range.

Accuracy — Within ± 0.4 dB/2 dB to 1.0 dB max over 14 dB dynamic range.

LIN — Within 10% over 8 divisions. Deviation between display modes (for full screen signal) ± 2 dB from 2 dB/div to 10 dB/div 0.5 divisions from 2 dB/div to LIN.

Reference Level —

Below 100 kHz — +30 dBm to -50 dBm, as the center frequency approaches 10 kHz.

7L18

30 Hz Resolution to 12 GHz

Microprocessor-aided
Front Panel Controls

Digital Display and Signal
Processing (Max Hold, Save A,
Split and Comparison Features,
and Algebraic Addition)

Calibrated Reference Level
Includes Internal Preselector

60 GHz with Optional Waveguide
Mixers

Preselected for Freedom from
Spurious Responses

80 dB Display Dynamic Range

< 10 Hz Residual FM
(Fundamental Mixing)

Fits all 7000 Series Mainframes
including USM-281 C

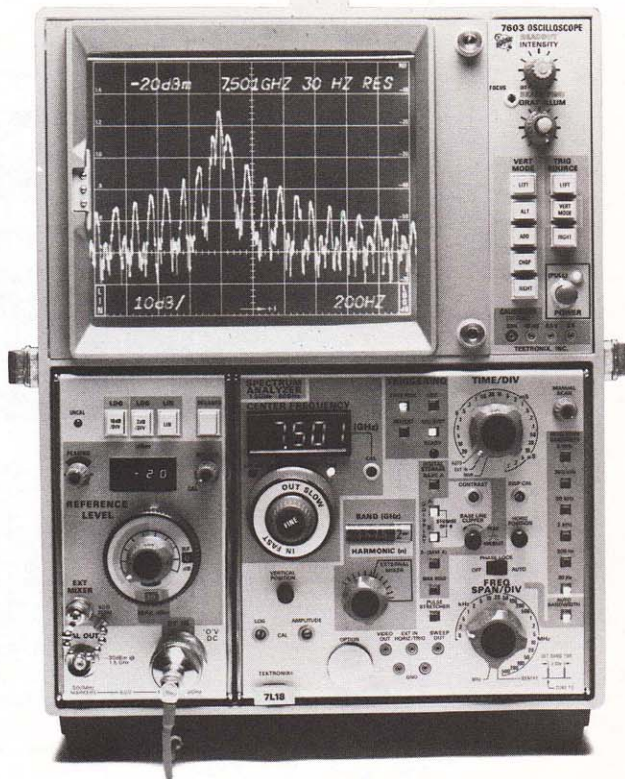

7L18 CHARACTERISTICS
FREQUENCY RELATED

Frequency Range — 1.5 GHz to 60 GHz
Tuning Range — With internal mixer: 1.5 GHz to 18 GHz.
With external mixer: 12.5 GHz to 60 GHz.

Frequency Span — Per Division: 20 calibrated span widths from 200 Hz/div to 500 MHz/div in a 1-2-5 sequence. Max span: depends on mixing mode. Span widths = N x 2 GHz where N is the mixing mode. Maximum span full screen is 8.5 GHz with internal mixer (9.5 to 18 GHz band). Zero span: non-sweeping tunable receiver mode.

Tracking Preselector — Internal and automatic 1.5 to 18 GHz. Rejection of harmonic mixing, image and multiple responses >70 dB.

| Frequency Bands— | (N = mixing mode) |
|----------------------------|-------------------|
| With internal mixer | N = 1— |
| 1.5 GHz to 3.5 GHz | N = 1— |
| 2.5 GHz to 4.5 GHz | N = 1+ |
| 3.5 GHz to 7.5 GHz | N = 2— |
| 6.5 GHz to 12.5 GHz | N = 3+ |
| 9.5 GHz to 18.0 GHz | N = 5— |
| With external mixer | (N = mixing mode) |
| 12.5 GHz to 24.5 GHz | N = 6+ |
| 14.5 GHz to 28.5 GHz | N = 7+ |
| 16.5 GHz to 32.5 GHz | N = 8+ |
| 18.5 GHz to 36.5 GHz | N = 9+ |
| 20.5 GHz to 40.5 GHz | N = 10+ |
| 30.5 GHz to 60 GHz | N = 15+ |

Frequency Accuracy — Dial Accuracy: (5 MHz + 20% of frequency span/div) x N [typically (1 MHz) x N with degauss activated].

Span Accuracy — 5% over center 8 horizontal divisions (typically 3%).

Stability — Residual FM stabilized 10 Hz p-p x N (typically 2 Hz p-p x N).

Frequency Drift — Long term drift: (at fixed center frequency after 2 hr warm up). Stabilized: 2 kHz/hr x N. Unstabilized: 50 kHz/hr x N.

Setability — Within 1 MHz for 1.5 GHz to 18 GHz (after 2 hr warmup). Within 10 MHz with external mixers (after 2 hr warmup).

Resolution — Bandwidth range: Selectable 6 dB bandwidths from 30 Hz to 3 MHz in decade steps plus auto. Shape factor: 4:1. 60 dB to 6 dB points, 300 Hz to 3 MHz, 12:1, 60 dB to 6 dB points, 30 Hz. Bandwidth accuracy: 6 dB points, 20%.

Phase Noise Sidebands — When phase locked, for fundamental (N=1) conversion: -70 dBc min at frequency offsets >20X resolution bandwidth settings.

Table 1
Sensitivity and Frequency Response with Internal Mixers — (Average noise level specified for 300 Hz resolution bandwidth. Frequency Response with 10 dB input attenuator setting.)

| Frequency Range (GHz) | Mixing Mode | Average Noise Level (dBm Max) | *Frequency Response Optimum Peaking (dB Max) |
|-----------------------|-------------|-------------------------------|--|
| 1.5—3.5 | 1— | -119 | ±1.5 |
| 2.5—4.5 | 1+ | -119 | ±1.5 |
| 3.5—7.5 | 2— | -109 | ±2.0 |
| 6.5—12.5 | 3+ | -107 | ±2.5 |
| 9.5—18.0 | 5— | -92 | ±3.0 |

*Includes mixer frequency response, RF attenuator frequency response, internal preselector frequency response, mixing mode gain variation, RF input vswr.

Table 2
Sensitivity and Frequency Response with External Mixers — (Average noise level specified for 3 kHz resolution bandwidth.)

| Frequency Range (GHz) | Mixing Mode | Average Noise Level (dBm Max) | Frequency Response (dB Max) |
|-----------------------|-------------|-------------------------------|-----------------------------|
| 12.5—18.0 | 6+ | -85 | — |
| **18.0—26.5 | 7+ | -90 | ±3 |
| **26.5—40 | 10+ | -85 | ±3 |
| **40—60 | 15+ | -75 | ±3 |

**High Performance Mixer Line.

AMPLITUDE RELATED

MEASUREMENT RANGE
Log Reference Level — -110 dBm to +40 dBm (+30 dBm max safe input level).

Log Display Dynamic Range — 80 dB.
Linear — 8 divisions with calibrated reference levels.
RF Attenuation Range — 6 steps @ 10 dB/step.

IF Gain Range — 9 steps @ 10 dB/step -20 dBm to -110 dBm (with zero RF attenuation) (-20 dBm is reduced noise position).

Sensitivity and Frequency Response — See tables 1 and 2.
Amplitude Accuracy — IF gain variation with different resolution bandwidths (at 25°C). Log: ±0.5 dB.

Reference level variation due to band switching: ±1.0 dB.
Display — Log 10 dB/div: ±1.0 dB/10 dB to a max of 2.0 dB. Log 2 dB/div: ±0.4 dB/2 dB to a max of 1.0 dB. Linear: ±10%.

IF Gain: ±1.0 dB/10 dB, ±2 dB max.
RF Attenuator: ±0.3 dB/10 dB to a max of ±0.7 dB.
Calibrator output: Amplitude -30 dBm ±0.5 dB, frequency 2.0 GHz ±0.01%. Absolute Calibration Accuracy 1.5 to 18 GHz. Overall accuracy is a function of measurement technique and includes the following parameters: Amplitude calibrator + band switching error + IF gain switching + RF attenuator switching + logging error + flatness + digital quantizing error (if digital storage is used). With appropriate technique, absolute accuracy of ±2.5 dB is usually achievable (1.5 to 18 GHz).

INPUT CHARACTERISTICS

Input Impedance — 50 Ω nominal (1.5 to 18 GHz).
Connector — Type "N" female.
Vswr — ≤1.35 for attenuator settings of ≥10 dB.
Maximum Input Level — 1 watt (+30 dBm).
Optimum Input Level — ≤ -30 dBm with zero RF attenuation.
Input Compression Point — ≥ -28 dBm from 1.5 to 1.8 GHz. ≥ -18 dBm from 1.8 to 18 GHz (both with zero RF attenuation).
L.O. Emission — -80 dBm, 1.5 to 18 GHz (10 dB input attenuator setting).

SPIRIOUS RESPONSES

Residual — (No signal present at input) with input attenuation at 0 dB, ≤ -110 dBm.

Intermodulation Distortion — Third order down 70 dB or more from any two full screen signals, when IF gain is not set to red zone (reduced noise position).

Mixed — All harmonic mixing, image and multiple responses down 70 dBc to 18 GHz.

DIGITAL STORAGE AND SIGNAL PROCESSING

Multiple memory display storage (A & B memory).
Save "A".
Digital display averaging.
Max hold.
B minus "Save A".
Disable for non-storage viewing.

GENERAL

Sweep Characteristics — 1 μs/div to 20 s/div in a 1, 2, 5 sequence plus auto, manual, and external. Accuracy ±5%.

Triggering Modes — Internal, external, free run, single sweep. Triggering source line, internal, external. Sensitivity: 1 div internal, 0.5 volt external (50 volts max).
Frequency Range: 15 Hz to 1 MHz.

Video Output — 500 mV ±5%/div of display.
Pulse Stretcher — Enhances pulsed RF measurements.

Degauss — Improves frequency measurement accuracy.
X, Y Output — Front panel pin jacks.

Uncal Light — Provides indication of uncalibrated display amplitude.

Peaking — Optimizes sensitivity and frequency response.

INCLUDED ACCESSORIES

1 Spectrum Analyzer Graticule 337-1439-01; 1 Spectrum Analyzer Graticule 337-1159-02; 1 50 Ω coaxial cable, 10 in 012-0208-00; 1 Adapter, BNC female to N male 103-0045-00; Plug-in to Mainframe Securing Kit 016-0637-00.

ORDERING INFORMATION

| | |
|---|-----------|
| 7L18 Spectrum Analyzer | \$17,500 |
| *7603 Oscilloscope | \$2555 |
| R7603 Oscilloscope (Rackmount) | \$2955 |
| Option 06 Internal S A Graticule | Add \$50 |
| Option 08 Protective Front Cover (Cabinet Only) | Add \$100 |
| *Suggested Mainframe: 7603 Option 08/Option 06 for maximum transportability. Has protective front cover (Option 08) and Spectrum Analyzer Graticule (Option 06). See 7000 Series pages for oscilloscope specifications and options. | |

OPTIONAL ACCESSORIES

| | |
|--|--------|
| General Purpose Waveguide Mixers | |
| Set 016-0640-00 | \$660 |
| Mixer 119-0097-01 12.4 to 18 GHz | \$145 |
| Mixer 119-0098-01 18 to 26.5 GHz | \$180 |
| Mixer 119-0099-01 26.5 to 40 GHz | \$220 |
| Cable 012-0748-00 | \$20 |
| Case 004-1651-00 | \$35 |
| High Performance Waveguide Mixers | |
| Set WM 490 3 | \$3260 |
| Mixer WM 490 K 18 to 26.5 GHz | \$975 |
| Mixer WM 490 A 26.5 to 40 GHz | \$975 |
| Mixer WM 490 U 40 to 60 GHz | \$1250 |
| Cable 012-0649-00 | \$25 |
| Case 004-1651-00 | \$35 |

7L5

Three-Knob Operation

Synthesizer Stability for Six-Digit Accuracy of Center Frequency Setting

Improved Digital Storage and Averaging

Reference Level Selection in 1 dB Steps

Absolute Calibration in dBm, dBV or Volts/Div

Tracking Generator Option for Swept Component Measurements

Changeable Input Impedance Modules to Accommodate any Impedance Requirement

Wide Dynamic Range and Nanovolt Sensitivity

Preset Reference Level and Dot Frequency for Extra Input Protection

CRT Readout of all Major Parameters

B Minus "Save A" Feature

The 7L5 is an audio/baseband spectrum analyzer plug-in that provides exceptional frequency accuracy and operator convenience through a combination of frequency synthesizer and digital technology.

The center frequency can be set with six digit accuracy immediately after turn-on. A built-in micro-computer decodes control settings, processes frequency span and reference level information and optimizes sweep time and resolution for the span chosen.

To accommodate a wide variety of user preferences, the 7L5 uses changeable plug-in input modules providing a variety of input impedances such as 50, 75, 600, or 1 meg-ohm. The built-in computer automatically adjusts the calibrator to provide the correct reference level for the impedance chosen.



Changeable modules permit the 7L5 user to adapt to new measurement requirements. Modules now available are the probe compatible L3 and L3-1. The L3 offers selectable internal 50 Ω , 1 M Ω , or 600 Ω impedance, while the L3-1 offers 75 Ω , 1 M Ω or 600 Ω . The module you select calibrates displays for the impedance in use.

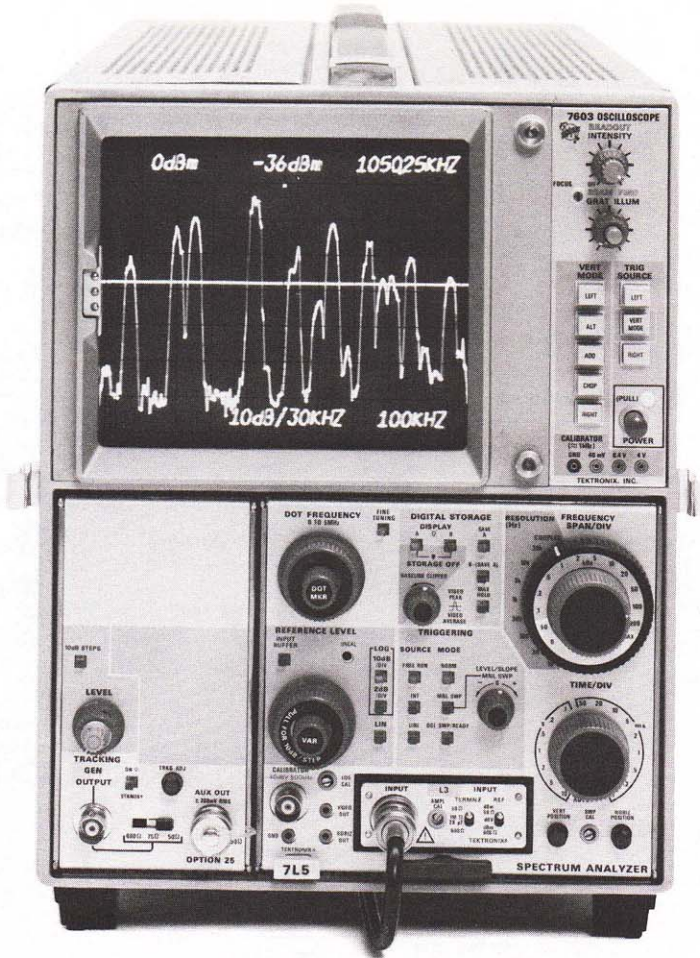

7L5 Option 25 Spectrum Analyzer with L3 Plug-in Module in a 7603 Option 06 Mainframe with internal spectrum analyzer graticule.

Digital storage, in addition to providing clean, easy-to-interpret displays, also makes such special functions as digital averaging and peak detection possible. The display is stored electronically and updated during each sweep. Two complete displays can be held in memory for comparison. A max hold function stores the maximum signal level over long periods of time to measure amplitude and frequency drift.

CRT readout displays the center frequency, reference level, resolution bandwidth, dB per division and frequency span.

The B minus "Save A" feature provides algebraic subtraction of two traces, so that changes in multi-signal spectra can be monitored.

7L5 CHARACTERISTICS

The following characteristics and features apply to the 7L5 Spectrum Analyzer and its options. They are applicable over the environmental specification criteria for the 7000 Series Mainframes.

FREQUENCY CHARACTERISTICS

Range — Input frequency range is 20 Hz through 5.0 MHz. Dot frequency range is 0 Hz through 4999.75 kHz tuned in 250 Hz steps. Dot accuracy: 0°C to 50°C \pm (20 Hz + 10^{-5} of dot frequency); 20°C to 30°C \pm (5 Hz + 2×10^{-6} of dot frequency).

Drift — Frequency drift is \leq 5 Hz/hour.

Residual Incidental Fm — Residual fm is \leq 1 Hz (p-p) for frequency spans of 50 Hz/div to 2 kHz/div. Residual fm is \leq 40 Hz (p-p) for frequency spans of 5 kHz/div to 500 kHz/div.

Resolution Bandwidth — 8 resolution bandwidths range from 30 kHz to 10 Hz. COUPLED switch position electronically couples resolution to span/div selection so that both are controlled by the same knob. Bandwidth accuracy @ 6 dB down is within 20% of selected resolution. Shape factor (60:6 dB ratio) is 10:1 or better for 10 Hz to 1 kHz and 5:1 or better from 3 kHz to 30 kHz. Amplitude change between resolution bandwidths is \leq 0.5 dB for 30 kHz to 100 Hz and \leq 2.0 dB for 30 kHz to 10 Hz.

SWEEP CHARACTERISTICS

Frequency Span — Provides calibrated frequency spans from 50 Hz/div to max (500 kHz/div) within 4% in 1-2-5 sequence.

Horizontal linearity is within 4% over the entire 10 div display. A 0-Hz/div position is provided for time domain operation.

CHARACTERISTICS WITH PLUG-IN INPUT IMPEDANCE MODULE

| INPUT CHARACTERISTICS Input Impedance — | L3 | L3-1 |
|--|---|------------------------------------|
| | | 50 Ω, 600 Ω 1 MΩ/28 pF |
| Input Power — Max input power for reference levels: above 0 dBm below 0 dBm | +21 dBm +21 dBm 100 V (peak AC + DC) @ 1 MΩ input z | |
| AMPLITUDE CHARACTERISTICS | | |
| Residual Response — Internally generated spurious signals (referred to input). | -143 dBV or less -138 dBV for calibrator and harmonics | |
| Sensitivity — Equivalent input noise for each resolution bandwidth setting is measured in VIDEO AVERAGE mode with 10 s/div sweep rate and INPUT BUFFER control off. Equivalent input noise for resolution bandwidth of: | 50 Ω *(equal to or better than) | 1 MΩ *(equal to or better than) |
| 10 Hz | -135 dBm | -148 dBV |
| 30 Hz | -133 dBm | -146 dBV |
| 100 Hz | -130 dBm | -143 dBV |
| 300 Hz | -125 dBm | -138 dBV |
| 1 kHz | -120 dBm | -133 dBV |
| 3 kHz | -115 dBm | -128 dBV |
| 10 kHz | -110 dBm | -123 dBV |
| 30 kHz | -105 dBm | -118 dBV |
| Sensitivity is further degraded 8 dB with INPUT BUFFER on. Noise level increases approx 10 dB operating in VIDEO PEAK mode. | | |
| Intermodulation Distortion — Within any frequency span, intermodulation products for two, on screen, signals of any input level: | 3rd order products at least 75 dB down 2nd order products at least 72 dB down at least 80 dB down | |
| of any input level up to -53 dBV/-40 dBm (50 Ω): | 2nd and 3rd order products at least 80 dB down | |
| of any input level with INPUT BUFFER on: | 2nd and 3rd order products at least 80 dB down | |
| Display Flatness — Peak-to-peak display variation over any frequency span. | 0.5 dB max (25 Hz to 5 MHz) 0.75 dB max (20 Hz to 5 MHz) (Add 0.5% quantization error in digital storage) 80 dB (full 8 div) | |
| On-screen Dynamic Range — | | |
| Reference Level** — In LOG mode, reference level refers to top horizontal graticule line. Calibrated in dB steps. | 1 dB and 10 dB steps | |
| Range — LOG 10 dB/div mode | -70 dBm to +21 dBm (50 Ω) -83 dBV to +8 dBV (1 MΩ) | |
| LOG 2 dB/div mode | -128 dBm to +21 dBm (50 Ω) -141 dBV to +8 dBV (1 MΩ) | |
| LIN mode | 20 nV/div to 200 mV/div in a 1-2-5 sequence | |
| Accuracy — When calibrated @ -40 dBV in LOG mode. | Within 0.2 dB/dB, to max of 0.25 dB/10 dB change in reference level | |
| Display Dynamic Range Accuracy — | | |
| LOG 10 dB/div mode | 0.05 dB per dB to 2 dB max for 80 dB full screen. | |
| LOG 2 dB/div mode | 0.1 dB per dB to 1 dB max for 16 dB full screen | |
| LIN mode | ±5% | |

*Note: dBm = dBV - 10 Log Z + 30 where Z = impedance
Example: dBV = [dBm (600 Ω) - 2.22]

**Note: A > sign is displayed by the reference level readout when the reference level is not calibrated and the UNCAL light is on. A < sign is displayed when the reference variable is out of its detent.

Sweep Rate — Time per div is selectable from 10 s/div to 0.1 ms/div in 1-2-5 sequence. An AUTO position permits automatic selection of optimum time/div depending on resolution and span/div settings.

Sweep rate accuracy is within 5% of the rate selected.

Triggering — Provides two triggering sources, INT (internal) and LINE, in addition to a FREE-RUN position.

When INT is selected, ac coupled signal components from the mainframe trigger source (left or right vertical amplifiers) are used.

When LINE is selected, ac coupled sample of mainframe ac line voltage is used.

Three triggering modes are NORM (normal), SGL SWP/READY (single sweep), and MNL SWEEP (manual sweep).

Trigger level is ≥ 1.0 div of internal signal for both NORM and SGL SWP modes over the approximate frequency range of 30 Hz to 500 kHz.

OUTPUT CONNECTORS

Video Out — Front-panel pin jack connector supplies the video (vertical) output signal at an amplitude of 50 mV/div ±5% (about the CRT vertical center) with source impedance of 1 kΩ. (Analog signal prior to digitization for storage).

Horiz Out — A front-panel pin jack connector supplies horizontal output signal (negative-going sawtooth that varies from about 0 to about -6 V dc with a source impedance of 5 kΩ).

Calibrator — Front-panel BNC connector supplies a calibrated 500 kHz squarewave output signal (derived from the analyzer's time base). Output amplitude is within ±0.15 dB of -40 dBV into the plug-in impedance.

OPTION 25 TRACKING GENERATOR CHARACTERISTICS

Frequency Range — 20 Hz to 5.0 MHz.

Output Impedance — 50 Ω, 75 Ω, or 600 Ω selected by a front panel switch.

Amplitude — The output level is calibrated in dBm or dBV and selectable in 10 dB or 1 dB steps. A vernier provides continuous variation between calibrated steps.

Range —
50 Ω, 0 dBm to -63 dBm
75 Ω, -6 dBm to -69 dBm
600 Ω -17 dBm to -80 dBm

Accuracy — (Max Output calibrated at 500 kHz)
50 Ω, 0 dBm ±0.25 dB
75 Ω, -6 dBm + 0.4, -0.2 dB
600 Ω -17 dBm +0.5, -0.1 dB

Attenuator —
Range: 0 to 63 dB in 10 dB or 1 dB steps.
Accuracy: Within 0.2 dB/dB to a max of 0.25 dB/10 dB absolute.

Flatness —
50 Ω and 75 Ω: Within 0.5 dB p-p.
600 Ω: Within 1.0 dB p-p.
Total System Flatness (7L5 with Option 25)
50 Ω and 75 Ω: Within 1.0 dB p-p.
600 Ω: Within 1.25 dB p-p.

Dynamic Range (7L5 with Option 25) — ≥110 dB.

Residual FM (p-p) —
Spans to 2 kHz/div: 2 Hz (7L5 with Option 25).
Spans 5 kHz/div or greater: 40 Hz (7L5 with Option 25).

Stability — 25 Hz/5 minutes after 10 minute warm-up decreasing to 25 Hz/hr max after 1 hr.

Spurious Suppression, 10 Hz to 5.0 MHz (harmonic and non-harmonic) — 40 dB or more with respect to the carrier.

Auxiliary Output — ≥200 mV RMS into 50 Ω.

ORDERING INFORMATION

7L5 Spectrum Analyzer \$9100
(Spectrum Analyzer requires L Plug-in Module.)

Option 25 with Tracking Generator Add \$1450
For a separate tracking generator. (One-wide field modification to be attached to an existing 7L5) Order 040-0810-00 \$1500

Included Accessories — Graticule, Spectrum Analyzer 337-1159-00 (7000 Series), and 337-1439-01 (7603). Filter, light blue 378-0684-00.

L3 Plug-in Module (1 MΩ, 50 Ω, 600 Ω) \$1500

Option 01 (1 MΩ, 75 Ω, 600 Ω) No Charge

†7603 Oscilloscope \$2555

†R7603 Oscilloscope (Rackmount) \$2955

Option 06 Internal S A Graticule Add \$50

Option 08 Protective Front Cover (Cabinet Only) Add \$100

†7704A Oscilloscope \$3995

†R7704 Oscilloscope \$6665

†Suggested Mainframe. See 7000 Series pages for oscilloscope specifications and options.

OPTIONAL ACCESSORIES

Tracking Generator, one-wide field modification kit, to be attached to an existing 7L5 040-0810-00 \$1500

2701 50 Ω Step Attenuator \$575

2703 75 Ω Step Attenuator \$600

75 Ω to 50 Ω Min Loss Attenuator (Ac Coupled)

011-0112-00 \$60

P6105 10X Probe, (2m) 010-6105-03 \$95

BALANCED INPUT TRANSFORMER

Frequency Range — 50 kHz to 3 MHz, usable from 10 kHz to 20 MHz.

Flatness — 0.25 dB p-p maximum (50 kHz to 3 MHz) including nominal 0.1 dB insertion loss.

Common-Mode Rejection — 25 dB minimum (50 kHz to 3 MHz).

Output Termination — Switchable between 124 Ω, 135 Ω, and NONE for bridging or external termination.

Connectors — WECO (0.37 in with 0.090 center) on 0.625 in spacing for balanced input. BNC for single-ended output.

Balanced Input Transformer 013-0182-00 \$270

Limited quantities in the L1 and L2 are still available. Call your nearest Spectrum Analyzer Sales Engineer for information.

7L12

100 kHz to 1800 MHz in One Display

Fully Calibrated Displays

300 Hz to 3 MHz Resolution

4:1 Resolution Bandwidth Shape Factor

70 dB On-screen Dynamic Range

IM Distortion 70 dB below Full Screen

Spurious Free Operation

Automatic Phase Lock

-115 dBm Sensitivity

The 7L12 Spectrum Analyzer is a modern, high-performance, swept front-end type of analyzer covering the frequency range up to 1.8 GHz. The unit employs phase lock stability and an ample selection of resolution bandwidths in an economical field or laboratory instrument.

The unit has a 3 MHz resolution mode for accurate measurement of pulse phenomena; the zero-span mode may be used to present a demodulated display of a signal for time domain measurements. A 4:1 resolution bandwidth shape filter introduced by Tektronix permits close-in measurements not possible with conventional filters. Noise measurements are also easily made due to the high sensitivity, video filters, and equivalent resolution and noise power bandwidth of the instrument.

The 7L12 fills two holes in any 3- or 4-hole 7000 Series Mainframe and features a complete time base so that other oscilloscope or time domain plug-ins may be used simultaneously. As with all 7000 Series Plug-ins, CRT READOUT will display the major parameters. For the 7L12, these include; reference level, dB/div, frequency span and resolution.

7L12 CHARACTERISTICS FREQUENCY CHARACTERISTICS

Range — 100 kHz to 1.8 GHz. (Usable below 100 kHz with degraded performance.)

Resolution Bandwidth — Resolution bandwidth selections from 300 Hz to 3 MHz. Shape factor 60 dB to 6 dB is 4:1 or better.

Stability — Within 50 kHz, after 2 hour warm-up, over a one hour period at a fixed temperature when phase locked. Within 100 kHz, when not phase locked, over a 1 hr period, at a fixed temperature.

Incidental Fm — 200 Hz (p-p) max when phase locked. 20 kHz (p-p) when not phase locked.

AMPLITUDE CHARACTERISTICS

Reference Level Range — Calibrated levels in decade steps from -100 dBm to +30 dBm, within ± 2 dB.

Log 10 dB/div:

70 dB dynamic range. Accuracy ± 0.1 dB/dB to a max of 1.5 dB.

Log 2 dB/div:

14 dB dynamic range. Accuracy ± 0.4 dB/2 dB to a max of 1.0 dB.

Linear:

— Provides a linear display, within 10%.

Cw Sensitivity — (Signal + noise = twice noise in LIN mode).
-115 dBm at 300 Hz, -108 dBm at 3 kHz, -100 dBm at 30 kHz, -90 dBm at 0.3 MHz, -80 dBm at 3 MHz. Sensitivity may decrease 2 dB at 1.7 GHz and 4 dB at 1.8 GHz.

Flatness — ± 1.5 dB over any frequency span.

7L12 with 016-0155-00 Blank Panel in 7613 Option 06 Variable Persistence Mainframe with internal spectrum analyzer graticule.

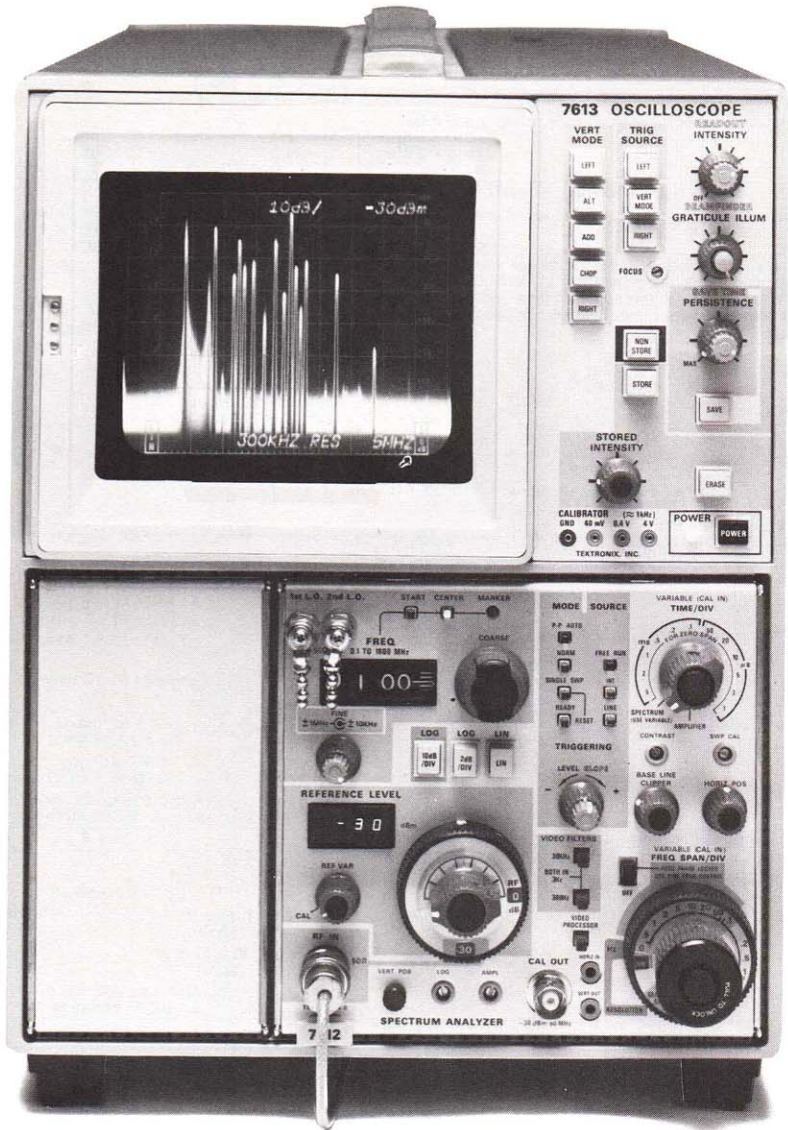

Spurious Responses —

Residual — (No signal present at input) with input attenuation at 0 dB. ≤ -100 dBm.

Intermodulation Distortion — Third order down 70 dB or more from two -30 dBm signals within any frequency span. Second order down 70 dB or more from two -40 dBm signals.

Mixed — All image, harmonic related, and out-of-band mixing responses are ≥ 70 dB down from a level of -30 dBm to the input mixer (0 dB input attenuation).

Dynamic Range — 70 dB. The VARIABLE control provides gain adjustment between any two 10 dB steps.

INPUT CHARACTERISTICS

Impedance — 50 Ω , nominal.

SWEEP CHARACTERISTICS

Frequency Span — 500 Hz/div to 100 MHz/div. A MAX SPAN position provides ≈ 1.8 GHz (180 MHz/div of span), and a 0 position provides fixed frequency operation for time domain display.

Sweep Modes and Rate — 10 ms/div to 1 μ s/div.

Triggering — Trigger signal source can be external, internal, or line voltage.

OUTPUT CONNECTIONS

Calibrator — 50 MHz comb, -30 dBm at 50 Ω .

Vert Out — ≈ 2 V full screen.

Horiz In — For use with chart recorder.

1st LO — For use with tracking generator or 1405 Sideband Adapter.

2nd LO — For use with tracking generator.

INCLUDED ACCESSORIES

Spectrum Analyzer Graticule, Clear plastic implosion shield with LOG, LIN, REF, and f (frequency) direction markings 337-1439-01 for 7403N and 7603 Oscilloscopes and 337-1159-02 for other 7000 Series Oscilloscopes, Amber Light Filter: 378-0684-01; Light Filter: 378-0625-07; 50 Ω Coaxial Cable, with BNC connectors, 6 foot: 012-0113-00; BNC Male to N Female Adapter: 103-0058-00.

ORDERING INFORMATION

| | |
|--|---------------|
| 7L12 Spectrum Analyzer | \$9350 |
| 7603 Mainframe | \$2555 |
| Option 06 Internal SA Graticule | Add \$50 |
| Option 08 Protective Front Cover | Add \$100 |
| Option 77 P7 Phosphor and Internal S A Graticule | Add \$35 |
| 7613 Variable Persistence Mainframe | \$4680 |
| Option 06 Internal S A Graticule | Add \$50 |
| Option 08 Protective Front Cover | Add \$100 |
| 7K11 CATV Pre-amplifier | \$1000 |

Extended Frequency Range to 2.5 GHz. Ask about the modified 7L12.

5L4N

- 20 Hz to 100 kHz
- Selectable Impedance
- Calibrated Appropriate to Impedance Selected
- Single-Ended Input
- Differential (Balanced) Input
- On Screen Dynamic Range 80 dB (Full 8 div)
- Intermod >70 dB Down
- Resolution Bandwidth 10 Hz to 3 kHz
- Auto Resolution
- Built-in Tracking Generator
- 20 Hz to 20 kHz Log Sweep*

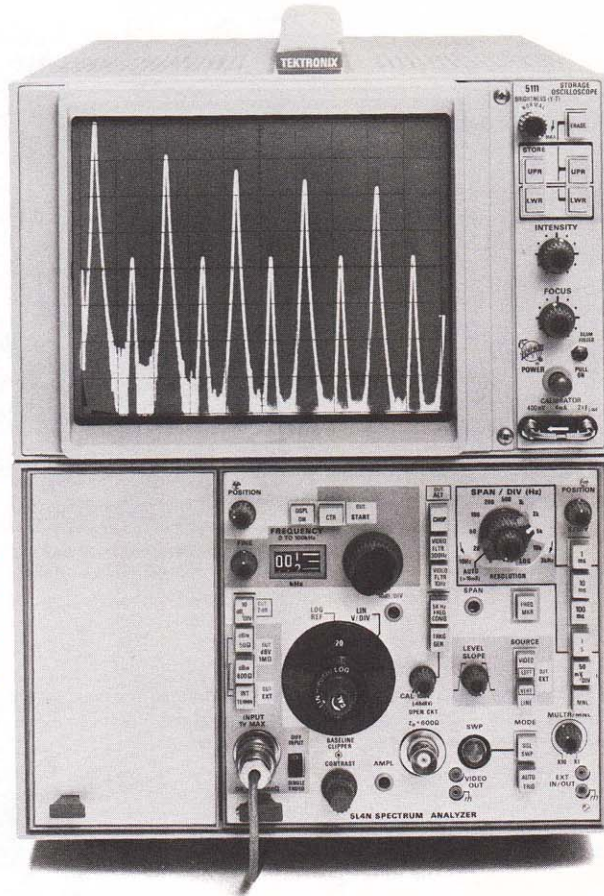

5L4N Spectrum Analyzer with 016-0452-00 Blank Plug-in Panel in a 5111 Storage Oscilloscope.

The 5L4N is a 20 Hz to 100 kHz spectrum analyzer that offers both high performance and economy. The analyzer features selectable input impedances, 80 dB of dynamic range and a built-in tracking generator.

This spectrum analyzer is especially suited for noise and distortion studies in the audio range and comes equipped for 20 Hz to 20 kHz log sweeps.

Many educators prefer this economical analyzer to teach frequency-related theory and demonstrate practical application in the areas of speech, sound, music, vibration, audio, broadcasting and many others.

5L4N Spectrum Analyzers can be used with any 5100 Series Mainframe. Only two compartments are occupied by the analyzer so that, with the addition of a vertical plug-in, basic oscilloscope functions may be obtained. We recommend the use of a 5111 Storage Oscilloscope for maximum utilization of the analyzer.

*100 Hz to 100 kHz also available.

FREQUENCY CHARACTERISTICS

Range — 20 Hz to 100 kHz. Accuracy ± 3 kHz (fine tune control midrange and span/div calibrated for 10 kHz).

Resolution Bandwidth — The resolution bandwidth is continuously variable from 3 kHz to 10 Hz. An AUTO mode provides the best resolution for the frequency scan and sweep rate selected. Signal level change over the resolution bandwidth range is 2 dB or less. Line frequency modulation of 50 Hz or more can be resolved up to 70 dB below the signal level. In the log sweep

mode the resolution bandwidth changes with frequency giving an effect similar to octave bandwidth sweeps.

Stability — Within 30 Hz over a 10 min period, at a fixed ambient temperature.

Incidental Fm — 2 Hz (p-p) or less.

AMPLITUDE CHARACTERISTICS

Reference Level Range —

Log 10 dB/div:
from -10 dBm/dBV to -70 dBm/dBV, within 0.4 dB/10 db to max of 1 dB at -70 dBm/dBV.

Log 2 dB/div:
from -10 dBm/dBV to -130 dBm/dBV within 0.4 dB/10 db to max of 1 dB at -70 dBm/dBV and 3 dB at -130 dBm/dBV.

Linear:
from 50 mV/div to 20 nV/div within 5% decade.

Cw Sensitivity (Signal Level + Noise = 2X Noise) — The following characteristics are applicable with the input internally terminated, or with a 600 Ω or less source impedance.

Resolution Bandwidth

| Display Mode | 3 kHz | 10 Hz |
|------------------|----------|----------|
| dBV | -123 dBV | -147 dBV |
| dBm 50 Ω | -110 dBm | -134 dBm |
| dBm 600 Ω | -121 dBm | -145 dBm |
| LINEAR | 680 nV | 45 nV |

Flatness (20 Hz-100 kHz) — Flatness remains within ± 0.2 dB, over any selected frequency span, with respect to the level of -40 dBV signal at 5 kHz. Intermodulation Distortion—with two signals, within any frequency span, that are less than or equal to the reference level:

- 10 dBm/dBV ≥ 70 dB down
- ≤ -20 dBm/dBV ≥ 75 dB down

Internal Spurious Signals — Equal to or ≤ -130 dBm/dBV referred to the input. Line related spurious ≤ -120 dBm/dBV.

Display Dynamic Range — 80 dB (8 div).

INPUT CHARACTERISTICS

Selectable Impedance — 1 M Ω /47 pF or 600 Ω or 50 Ω (single-ended or differential).

Differential Input Characteristics — Full screen limit is ≈ 300 mV to 400 mV. Common-mode rejection ratio is 70 dB or more.

Single-Ended Input Characteristics — Max signal input for linear operation: -10 dBm/dBV or 0.316 V RMS.

SWEEP CHARACTERISTICS

Linear Frequency Span — 20 Hz/div to 10 kHz/div, 1-2-5 sequence. 4% accuracy.

Log Frequency Span — 100 Hz to 100 kHz internally reprogrammable from 20 Hz to 20 kHz.

Zero Frequency Span — Analyzer operates as a fixed tuned receiver for time-domain displays.

Internal Sweep Sources — Time base 1 s/div to 1 ms/div (increased up to X10 with multiplier).

Triggering — Internal at least 0.1 div. External at least 250 mV. Slope and level selection are provided. Auto Trigger provides a sweep baseline when a trigger signal is absent. Single sweep provided.

Manual Sweep — Provided.

External Sweep — Requires 0 V to 500 mV ± 50 mV; from a 1 k Ω or less source to sweep the full span.

OUTPUT CONNECTIONS

Tracking Generator — 600 Ω source. Calibrated output level is -40 dBV ± 0.2 dB (10 mV) open circuit, or -46 dBV when terminated into 600 Ω . Output level can be varied from ≈ 0.001 V to 0.1 V open circuit.

5 kHz Freq Comb — 600 Ω source of 5 kHz $\pm 0.005\%$ markers for span calibration.

Video Out — Provides 250 mV $\pm 5\%$ of video signal per display div (0 V to 2 V). Source impedance is about 1.0 k Ω .

Ext In/Out — Provides 500 mV ± 25 mV, per div of span from 0 to 5 V, when using internal or manual sweep.

INCLUDED ACCESSORIES

013-0156-00 Adapter, Floating BNC to Dual BNC. 175-1178-00 BNC to Pin Jack Adapter Cable. 331-0429-00 Log Graticule (20 Hz-20 kHz).

ORDERING INFORMATION

5L4N Spectrum Analyzer \$4720

We recommend that the Plug-in 5L4N be ordered with a storage mainframe.

5111 Storage Oscilloscope (Cabinet) \$2100

Option 02 Protective Front Cover Add \$25

R5111 Storage Oscilloscope (Rackmount) \$2150

OPTIONAL PLUG-INS FOR TIME DOMAIN USE

5A15N Single Trace Amplifier \$300

5B10N Time Base Amplifier \$460

OPTIONAL ACCESSORIES

010-0160-00 10X Probe P6006 (6 ft.) \$80

016-0452-00 Blank Plug-in Panel \$15

2701 Step Attenuator (50 Ω) \$575



600 Ω Attenuator, 51 dB in 1 dB steps
011-0093-00 \$295

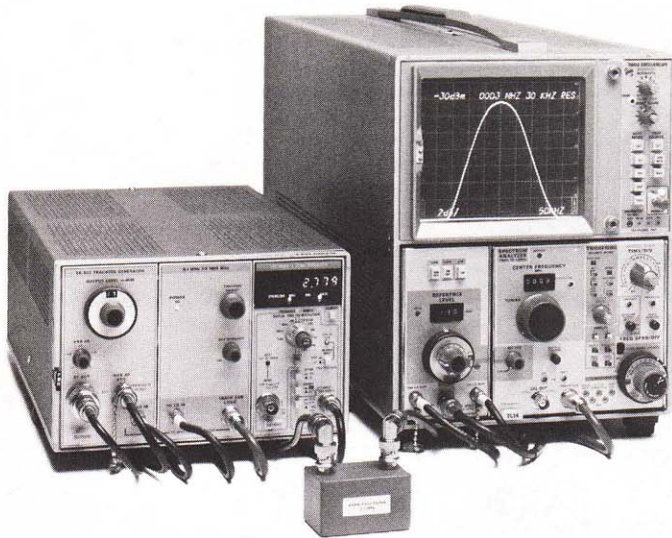

For swept frequency tests and precise frequency measurements, the TR 502 Tracking Generator may be used with a DC 508A Option 07 Digital Counter, in a TM 503 Option 07 Power Module, with a 7L14 Spectrum Analyzer in 7603 Option 06 Mainframe.

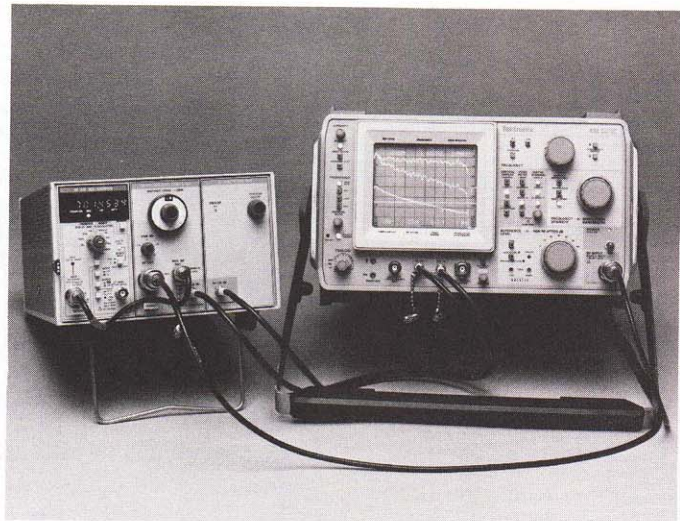

TR 503 Tracking Generating used with a DC 508A Option 01 Digital Counter, in a TM 503 Power Module, with a 492 Spectrum Analyzer.

TR 502/TR 503

TR 502 Has Automatic Counter Dot Marker When Used with DC 508A Option 07 and 7L14

The TR 502 works with the 7L12 and 7L14 and the TR 503 works with the 492/492P/or 496/496P Spectrum Analyzers to provide constant level, calibrated rf sources for swept frequency tests to 1800 MHz.

When used as a cw source, with the analyzer in a manual mode, these systems have excellent stability. This stability enhances the narrow bandwidth measurement capability of the analyzer/tracking generator combination.

The tracking generators are two-wide units compatible with the TM 500 Modular Instrument Series.

The TR 502/TR 503 AUX RF OUTPUT may be used to drive a frequency counter. Frequencies up to 1800 MHz may be measured accurately in the presence of high level adjacent signals to the sensitivity limits of the analyzer.

The tracking generator sweep rates are controlled with the spectrum analyzer, and the output level is controlled from the tracking generator. The output frequency of the tracking generator is the same as the frequency of the analyzer at any instant of the sweep.

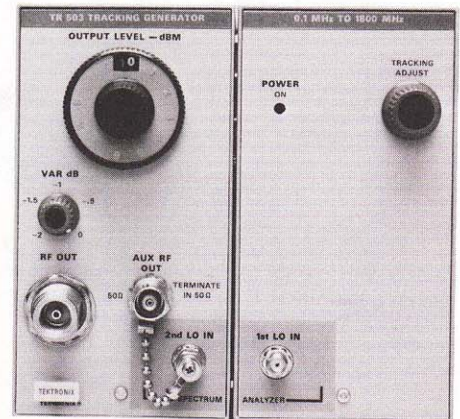

OUTPUT CONNECTORS

Rf Out — 50 Ω nominal impedance, vswr 2:1 or less.

Aux Rf Out — For use with frequency counter.
Included accessories TR 502 — Two 50 Ω coaxial cables (012-0649-00), logic interface cable, (012-0648-00), adapter N male to BNC female (103-0045-00), Adapter 3mm male to BNC female (015-1018-00), retainer plug-in (343-0604-00).

Included accessories TR 503 — Two 50 Ω coaxial cables, 28.5 in. (012-0649-00), Adapter, N male to BNC female (103-0045-00), Retainer Plug-in 343-0604-01.

CHARACTERISTICS

| | TR503/492/492P 496/496P | TR502/7L14 | TR502/7L12 |
|-------------------------|---|--|--|
| Freq. Range | 100 kHz — 1.8 GHz | 100 kHz — 1.8 GHz | 100 kHz — 1.8 GHz |
| Output Level | (Max) 0 dBm \pm 0.5 dB | 0 dBm \pm 0.5 dB | 0 dBm \pm 0.5 dB |
| Range | 0 to -59 dB in 10 dB and 1 dB steps | 0 to -59 dB in 10 dB and 1 dB steps | 0 to -59 dB in 10 dB and 1 dB steps |
| Flatness | Within \pm 2.25 dB Max from 100 kHz to 1.8 GHz (Typically \pm 1.5 dB) | Within \pm 2 dB max from 100 kHz to 1.8 GHz (Typically \pm 1.5 dB) | Within \pm 3.0 dB max from 100 kHz to 1.8 GHz (Typically \pm 2.0 dB) |
| Dynamic Range | \geq 110 dB | \geq 110 dB | \geq 100 dB |
| Residual FM | 50 Hz p-p | 10 Hz p-p | 200 Hz p-p |
| Output Impedance | 50 Ω Nominal, VSWR 2:1 or less to 1.8 GHz | 50 Ω nominal, VSWR 2:1 or less to 1.8 GHz | 50 Ω nominal, VSWR 2:1 or less to 1.8 GHz |
| Auxiliary Output | 0.1 V RMS into 50 Ω Load | 0.1 V RMS into 50 Ω Load | 0.1 V RMS into 50 Ω Load |
| Spurious Output | Harmonic 20 dBc Non Harmonic 40 dBc | Harmonic 20 dBc Non Harmonic 40 dBc | Harmonic 20 dBc Non Harmonic 40 dBc |

ORDERING INFORMATION

TR 502 Tracking Generator \$6300

Suggested Complementary Items

TM 503 Option 07 Power Module \$310

DC 508A Option 07 Digital Counter \$1825

Blank Panel 016-0195-03 \$21

10 dB, 3 mm attenuator 307-0553-00

(used in the 2nd LO input line to improve

TR 502/7L12 isolation) \$30

TR 503 Tracking Generator \$6300

Suggested Complementary Items

TM 503 Power Module \$285

DC 508A Option 01 Digital Counter Add \$1775

Blank Panel 016-0195-03 \$21



1405/7L12 TV Sideband Analyzer System.



1405 TV Sideband Adapter

Response of Transmitter Under Test Within ± 0.2 dB

Frequency Response of Rf and If Circuits for Transmitters with Frequency to 1 GHz

Video Circuits Can Be Swept

For In-service Testing, Use of External Blanking Allows Either Full-field or Single-line Operation

Check Aural Fm Deviation with Built-in Bessel Null Technique

Flexible Marker System Will Accept Standard Crystals

To analyze the sideband response of a television transmitter, the 1405 Sideband Adapter is used with a spectrum analyzer, such as the 7L12 or 7L14. The 1405 generates a composite video signal, the "picture" portion of which is a constant-amplitude sinusoidal signal that sweeps 15-0-15 MHz. This signal is applied as modulation to a television transmitter; the output is then displayed on the spectrum analyzer, and appears as the response curve of the transmitter under test. The 1405/Spectrum Analyzer combination will display the frequency response characteristics of rf and if circuits for transmitters with frequencies to 1 GHz. Video circuits (zero frequency offset) can also be analyzed.

Complete specifications and prices are available in the Television Products Catalog.

ORDERING INFORMATION

1405 TV Sideband Adapter (525/60 Markers) \$5000
Option 01 TV Sideband Adapter (625/50 Markers) Add \$200

OPTIONAL ACCESSORIES

Rackmount-conversion kit for mounting 1405 or 1405 Option 01 in std. 19 in rack 016-0489-00 \$285

2701, 2703 Step Attenuators

The 2701 and 2703 Step Attenuators are laboratory quality, bench top instruments for attenuation of large value radio frequency signals. The 2701 50 Ω Attenuator is particularly useful in making receiver sensitivity and distortion measurements. The range of attenuation is 0 to 79 dB, selected in 1 dB steps with tens and units cam switches. A front-panel switch selects DC, AC, or DC TERM (a 50 Ω precision termination).

The 2703 75 Ω Step Attenuator is tailored for television, CATV, telephone and radio applications. A front panel switch extends the range to 109 dB, making the attenuator an ideal accessory for wide-range measurements such as cross modulation, signal-to-noise and receiver sensitivity. A dc block has been incorporated for both rear-panel ports to protect the attenuator against accidental burnout from high dc offsets or ac power on center conductors.

The board assemblies and thick-film hybrid attenuation chips used in both instruments are mounted in a sturdy metal housing; solid top and bottom plates provide excellent mechanical and electrical stability. The two cam switches which select individual chips operate through gold-plated switch contacts. Held on a four-layer circuit board with spring clips, the chip substrates can be replaced easily in the field.

The attenuators may be used for frequencies up to 2 GHz, with slight degradation of the attenuation accuracy and vswr characteristics specified at 1 GHz.

ORDERING INFORMATION

2701 50 Ω Step Attenuator \$575
2703 75 Ω Step Attenuator \$600

STEP ATTENUATOR CHARACTERISTICS

| CHARACTERISTICS | 2701 | 2703 |
|-------------------------|--|---|
| Attenuation | 0 to 79 dB in 1 dB steps | 0 to 109 dB in 1 dB steps (Including extra 30 dB range) |
| Impedance | 50 Ω nominal | 75 Ω nominal |
| Frequency | Dc to 1 GHz | 3 kHz to 1 GHz* |
| Max Average Input Power | 1.5 W to 65°C. | 1.5 W to 65°C |
| Signal Coupling | Dc, ac, and dc terminated at one port only | Ac only both PORTS* |
| Size | 7.5 in lg x 4.5 in w x 2.5 in h | 7.5 in lg x 4.5 in w x 2.5 in h |
| Connector | Type BNC Female 50 Ω | Type BNC Female 75 Ω |

*Blocking capacitors may be removed for specialized applications.

7K11 CATV Preamplifier

This plug-in preamplifier is designed for spectrum analyzer applications where extra sensitivity is required. This amplifier is tailored to the CATV and field intensity measurement markets, providing a 75 Ω input impedance and calibration in dBmV. The low noise figure makes the preamplifier well-suited for signal-to-noise and low-level radiation measurements.

CHARACTERISTICS

(with 7L12 and 7L14)

Frequency Range — 30 MHz to 890 MHz.

Display Flatness — ± 1.0 dB, with respect to the level at 50 MHz over the frequency range of 50 MHz to 300 MHz; increasing to +2.0 dB, -2.5 dB over the full frequency range.

Sensitivity — Signal + noise = 2X noise, in LIN mode at 50 MHz, -90 dBmV at 30 Hz, -80 dBmV at 300 Hz, -73 dBmV at 3 kHz, -65 dBmV at 30 kHz, -55 dBmV at 300 kHz, -45 dBmV at 3 MHz. Noise figure is no >5 dB.

Intermodulation Distortion (with 7L12 or 7L14) — Imd products and harmonics from two signals within the frequency range are 70 dB or more down from the reference level for: third order intermodulation with two signals at the reference level (full screen).

Reference Level — Calibrated level in 1 dB steps from +79 dBmV to 0 dBmV. Accuracy is referenced to the +30 dBmV calibrator at 50 MHz.

Input Impedance — 75 Ω .

Calibrator — 50 MHz $\pm 0.01\%$ with an absolute amplitude level of +30 dBmV ± 0.3 dB, from 75 Ω .

Accessories — BNC to BNC 50 Ω Cable, 5.5 in: 012-0057-01; BNC to F Adapter: 013-0126-00; BNC to BNC 75 Ω Cable, 42 in: 012-0074-00.

Order 7K11 CATV Preamplifier \$1000

A limited quantity of the SW 503 Option 01 is still available. Call your nearest Spectrum Analyzer Sales Engineer for information.

PADS AND ADAPTERS

| | |
|---|--------|
| 75 Ω to 50 Ω Minimum Loss Attenuator with dc block, 5.7 dB loss 011-0112-00 | \$60 |
| 75 Ω to 50 Ω Matching Attenuator with 11.25 dB conversion factor from dBm to dBmV with dc block 011-0118-00 | \$60 |
| Fixed 10 dB attenuator with 3 mm fittings for use with TR 502 with 7L12 307-0553-00 | \$30 |
| Dc Block BNC to BNC max dc potential 50 volts 015-0221-00 | \$85 |
| "F" Female to BNC Male Adapter 013-0126-00 | \$15 |
| BNC Female to "F" Male 103-0158-00 | \$8.50 |
| Calibrator Jumper 50 Ω BNC to BNC 5.5 in 012-0214-00 | \$35 |
| Jumper Cable BNC to BNC 50 Ω 42 in 012-0057-01 | \$17 |
| Jumper Cable BNC to BNC 75 Ω , 42 in 012-0074-00 | \$17 |
| "N" Female to BNC Male 103-0058-00 | \$7.00 |

PROTECTIVE VINYL COVERS

For extra protection in field environments, soft vinyl covers are available to fit over the entire cabinet model mainframe or instruments.

| | |
|--|------|
| 7000 Series 3 Hole Mainframe Cover 016-0192-01 | \$20 |
| 7000 Series 4 Hole Mainframe Cover 016-0531-00 | \$20 |
| 5000 Series Mainframe Cover 016-0544-00 | \$25 |

RIGID FRONT COVERS

Solid snap on or friction fit covers are available to protect the instruments in transit or field use.

See appropriate spectrum analyzer and mainframe ordering information regarding the Option 08 Protective Front Cover for 7603 and 7613, or the Option 02 Protective Front Cover for 5100 Series Mainframes.

Protective Front Cover for existing 7603 or 7613 Mainframes:

| | |
|-------------------------|-------|
| Blue, 040-0835-00 | \$130 |
| Gray, 040-0628-00 | \$135 |

GRATICULES, FILTERS

Plastic Implosion Shield and S A Graticule 7613 and 7623 Mainframes 378-0625-07

Plastic Implosion Shield and S A Graticule 7403 and 7603 Mainframes 337-1439-01

Plastic Implosion Shield and S A Graticule All other 7000 Series Mainframes 337-1159-02

(Internal graticules are available with most 7000 Series Mainframes)

Emc Metal Screen Mesh Filter for 7500, 7700 Series Instruments 378-0603-00

Emc Metal Screen Mesh Filter for 7400 Series Instruments 378-0696-00

Audio 20-20 kHz Log Graticule for 5000 Series Instruments 331-0429-00

Complete selection of colored filters is available in the accessories section.

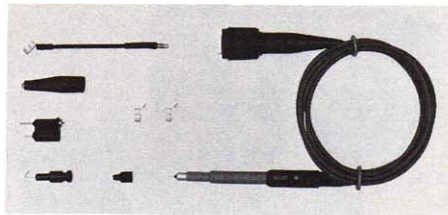

PROBES

A variety of probes is available in varying frequency and impedance ranges that can be used with the 7L12, 7L14, 492 and 496 Spectrum Analyzers:

| | |
|---|-------|
| FET Probe P6201 to 900 MHz 010-6201-01 | \$990 |
| FET Probe P6202A to 500 MHz 010-6202-03 | \$530 |
| Conventional Probe P6056 Dc to 3.5 GHz 6 ft. 010-6056-03 | \$140 |
| Conventional Probe P6057 Dc to 1.4 GHz with Adapter 010-6057-03 | \$145 |
| Current Probe P6022 to 150 MHz 015-0135-00 | \$325 |

Complete specifications are available in the probes and accessories section.

CAMERAS

A camera can greatly enhance the versatility of a spectrum analyzer. Many different units are available. However, the most popular units for the 5000, 7000 and 490 Series Spectrum Analyzers are:

| | |
|---------------------------------|--------|
| Polaroid Film Pack C-59AP | \$1165 |
| C-5C Camera | \$500 |

Complete specifications on all cameras are available in the Camera section.

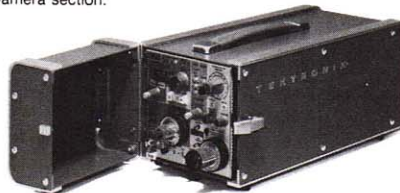

CARRYING CASES AND MOUNTS

Specialized carrying cases are available in 2 forms to protect your spectrum analyzer.

Metal carrying cases are available for the 7L12 or 7L14 Plug-in units.

Military style fiberglass and foam type transit cases can be custom fitted to many of the instruments.

A special mounting bracket assembly can be fitted to bolt the analyzer securely into the mainframe if desired. Securing Kit, fits 7L12 or 7L14

016-0637-00

3-wide Carrying Case for 7L14, 7L5 Option 25, etc. 016-0626-00

2-wide Carrying Case for 7L12, 7L5, etc. 016-0625-00

Luggage-type Carrying Case for 7603 Opt 08, 7613 Opt 08 016-0628-00 (Analyzer must have 016-0637-00 Securing Kit)

Hard Case (transit) for the 49X (016-0658-00)

Soft Case for the 49X (016-0659-00)

016-0637-00 Securing Kit)

016-0658-00)

016-0659-00)

Your local Sales Office or representative can quote prices and availability on any of these accessories.

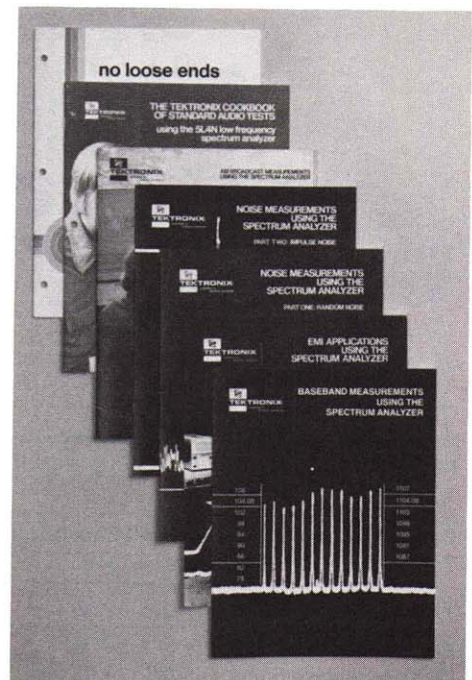

Numerous application notes and magazine article reprints on spectrum analyzer measurements are available. Notes on baseband, emc, am, fm, two-way radio and television measurements, audio amplifier testing, noise and pulse testing, and others have been written to help you with your measurements.

In addition, our staff of specialists stands ready to help you solve any special measurement problems. Contact your local Tektronix Sales Office or representative.



Option 08 protective front cover is shown with 7613 Mainframe.

INSTRUMENTS DIVISION

The Instruments Division provides the world its largest selection of instruments which generate, acquire and analyze electronic events. Digital and analog technologies are applied, along with systems control and interfacing, in support of a broad range of applications for engineers, scientists and technicians. Jim Koehn, division sales manager, is shown with just a few of the hundreds of instruments contained in the following pages. Jim is standing in the central lobby of the division's new 489,000 square foot manufacturing facility near Vancouver, Washington.

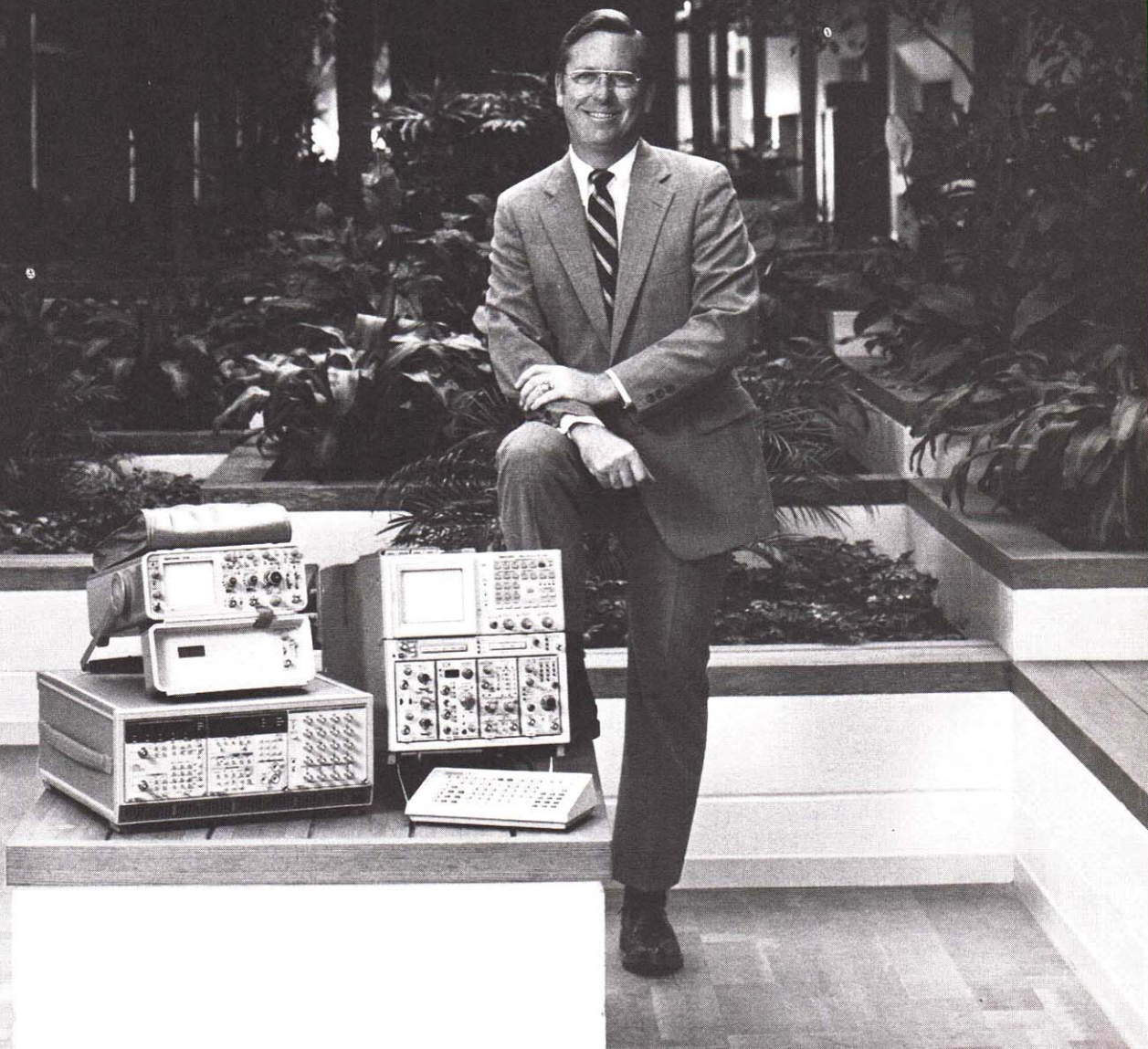

CONTENTS

| | |
|--|-----|
| Modular vs Monolithic Design | 136 |
| Portability | 137 |
| CRT vs Digital Storage | 138 |
| CRT Characteristics..... | 140 |
| Key Specifications & Features | |
| Oscilloscopes & Related Equipment | 141 |
| Amplifier Considerations | 141 |
| Time Bases | 142 |
| Sampling | 142 |

TWO BASIC CONFIGURATIONS

There are two basic configurations for test and measurement instruments. Modular instruments, more often called plug-in or laboratory models when referring to oscilloscopes, combine a mainframe and one or more interchangeable plug-in subassemblies. Integrated instruments, such as monolithic oscilloscopes, are one-piece units.

Although portable instruments are traditionally designed as integrated units, not all monolithic instruments meet all the objectives of portability. On the other hand, some modular systems, such as the Tektronix General Purpose Instrument line, are designed for easy transport right into the field. See the reference section on portability for more details.

Modular Design

Versatility is the primary advantage of a modular instrument. Many more functions than could be economically or practically combined in a single unit can be made available in separate plug-ins. You, the user, can then choose the ones that serve you best.

Because a modular instrument is so versatile, it can also make use of advances in instrument design. New plug-ins or mainframes can be added, that within the basic limitations of the other units, add new functions or higher performance.

Modularity also allows plug-ins and mainframes to be shared between various uses. For example, with the TM 500 Line, the same general test and measurement plug-ins used in the lab for design work can be quickly inserted into a portable mainframe and easily carried to a service problem. Alternately, where demand warrants it, the identical model plug-ins can be supplied to both field service and laboratory personnel, assuring the repeatability of measurements and minimizing training time.

MODULAR NONSTORAGE OSCILLOSCOPES

| Product | Bandwidth** | Minimum Deflection Factor | Number of Traces | Maximum Sweep Rate | Delayed Sweep | Page | Price† |
|-----------------|--|---|----------------------|--------------------|---------------|------------|------------------|
| 7104 | 1 GHz | 10 mV/div at BW | up to 4 | 200 ps/div | X | 156 | \$18,945 |
| 7904 R7903 | 500 MHz | 10 mV/div at BW 10 μV/div 1 mA/div | up to 4 | 500 ps/div | X | 158 158 | \$8000 \$7545 |
| 7844 | 400 MHz | 20 mV/div at BW 10 μV/div 1 mA/div | up to 4 Dual-Beam | 1 ns/div | X | 160 | \$11,900 |
| 7704A Opt 09 | 250 MHz | 20 mV/div at BW 10 μV/div 1 mA/div | up to 4 | 2 ns/div | X | 162 | +\$500 |
| 7704A | 200 MHz | 10 mV/div at BW 10 μV/div 1 mA/div | up to 4 | 2 ns/div | X | 162 | \$3995 |
| 7603 | 100 MHz | 5 mV/div at BW 10 μV/div 1 mA/div | up to 4 | 5 ns/div | X | 164 | \$2555 |
| 5440 | 50 MHz | 5 mV/div at BW 10 μV/div 0.5 mA/div | up to 8 | 5 ns/div | X | 210 | \$2390 |
| 5110 | 2 MHz | 1 mV/div at BW 10 μV/div 0.5 mA/div | up to 8 | 100 ns/div | X | 214 | \$1300 |
| 7603N11S | Ruggedized oscilloscopes system [meets or exceeds MIL-0-24311 (EC) (AN/USM 281 Specs)] | 5 mV/div at BW | up to 2 | 5 ns/div | X | 166 | \$7160 |

**Bandwidths are real time

†Price does not include plug-ins.

Sampling plug-ins that extend bandwidths to 14 GHz are available for most mainframes.

Plug-ins can also extend the original instrument range to other functions. Digital multimeters, curve tracers, spectrum analyzers and logic analyzers are just a few examples of the many specialized plug-ins Tektronix offers for modular oscilloscopes.

Oscilloscopes

There are two lines of Tektronix Modular Oscilloscopes to choose from. The Tektronix 5000 Series uses two amplifier plug-ins plus one time base. The Tektronix 7000 Series, which offers higher performance in a number of areas, can accept up to two vertical-channel plug-ins and two time bases or other horizontal units simultaneously. In-depth coverage begins on page 148.

General Purpose Instruments

The Tektronix TM 500 Line is a modular system. One-three-four-five-and six-compartment mainframes accept a broad selection of plug-in units. The mainframe unit provides a common primary power supply, keeping total instrument weight, size, and cost down. Just as importantly, TM 500 Mainframes also provide a signal control and data interface between modules. This allows TM 500 units to work either individually or together as integrated measuring systems. The Tektronix General Purpose Instrument line is extensive: more than 40 units, including power supplies, signal sources, oscilloscopes modules, a logic analyzer, digital multimeters, counter/timers, and more. Custom plug-in kits allow you to add your own unique circuits. With this feature, you can also apply TM 500's capability to unusual applications. In-depth coverage begins on page 252.

Other Modular Devices

| | |
|---|----------|
| Logic Analyzers | page 43 |
| Spectrum Analyzers | page 118 |
| Waveform Digitizing Instruments and Systems | page 143 |
| Curve Tracers | page 301 |

Integrated and Monolithic Devices

Taking the other design approach to instrument design, integrated instruments are optimized for a single range of functions. One-piece instrument design provides reduction in weight, increased ease of use, smaller size, and usually lower power requirements when a definite function is required.

Many oscilloscopes of this type are particularly designed for portable use, with rugged cases, environmental protection, and internal or external battery power. In-depth coverage begins on page 222.

Tektronix also offers many other one-piece products designed to be used alone or as elements of larger systems. Each performs its specialized task economically yet fully because it is designed for a specific type of use:

| | |
|------------------------------|----------|
| Data Communication Analyzers | page 26 |
| Graphic Terminals | page 68 |
| OEM Imaging Products | page 94 |
| TV Products | page 103 |

To sum up, modular instruments feature versatility, opportunities for tailor-made selection of functions, and a wide range of measurement capability. Integrated designs are strongest in economy for single functions, ruggedness, and portability.

PORTABLE NON-STORAGE OSCILLOSCOPES

| Product | Bandwidth | Minimum Deflection Factor | Dual-Trace | Maximum Sweep Rate | Delayed Sweep | Page | Price |
|---------|-----------|-----------------------------|------------|--------------------|---------------|------|--------|
| 485 | 350 MHz | 5 mV/div at BW | X | 1 ns/div | X | 228 | \$6975 |
| 475A | 250 MHz | 5 mV/div at BW | X | 1 ns/div | X | 230 | \$4410 |
| 475 | 200 MHz | 2 mV/div at BW | X | 1 ns/div | X | 230 | \$3960 |
| 465B | 100 MHz | 5 mV/div at BW | X | 2 ns/div | X | 232 | \$2995 |
| 465M | 100 MHz | 5 mV/div at BW | X | 5 ns/div | X | 234 | \$3500 |
| 2337 | 100 MHz | 5 mV/div at BW | X | 5 ns/div | X | 223 | \$3350 |
| 2336 | 100 MHz | 5 mV/div at BW | X | 5 ns/div | X | 223 | \$3075 |
| 2335 | 100 MHz | 5 mV/div at BW | X | 5 ns/div | X | 223 | \$2775 |
| 2215 | 60 MHz | 2 mV/div at BW | X | 5 ns/div | X | 226 | \$1400 |
| 2213 | 60 MHz | 2 mV/div at BW | X | 5 ns/div | X | 226 | \$1100 |
| 335 | 35 MHz | 10 mV/div at BW 1 mV/div | X | 20 ns/div | X | 236 | \$2760 |
| 305 | 5 MHz | 5 mV/div at BW | X | 100 ns/div | X | 237 | \$2120 |
| 221 | 5 MHz | 5 mV/div at BW | X | 100 ns/div | X | 238 | \$1600 |
| 213 | 1 MHz | 20 mV/div at BW 5 mV/div | | 400 ns/div | X | 239 | \$2100 |
| 212 | 500 kHz | 10 mV/div at BW 1 mV/div | X | 1 μs/div | X | 240 | \$1545 |
| SC 504† | 80 MHz | 5 mV/div at BW | X | 5 ns/div | | 286 | \$2910 |
| SC 502† | 15 MHz | 5 mV/div at BW 1 mV/div | X | 20 ns/div | | 288 | \$2140 |

†The SC 502 and SC 504 are oscilloscopes that must be plugged into a TM 500/TM 5000 Mainframe for operation. Please turn to page 252 for more information.

Portable Oscilloscopes

For oscilloscopes, a combination of factors must be considered. Small size and lightweight are obviously important, but the degree depends on the application and the uses. Similarly, ruggedized cases or dustcovers may be required. The Tektronix 200 Series Oscilloscopes, for example, are less than 8 x 14 x 23 cm (3 x 6 x 9 in), weigh less than 1.6 kg (3.5 lb) and are specifically designed and packaged for field use. The 300 Series all weigh less than 5 kg (11 lb). The high-performance Tektronix 400 Series models, 10.5 to 15 kg (21 to 33 lb), are designed as portables too. Our most recent oscilloscopes also reflect the emphasis on portability. The 2213 and 2215 are dual trace, delayed sweep, 60 MHz instruments that weigh less than 6.1 kg (13.5 lb). The 2300 100 MHz portable scopes are not only lightweight (starting at 7.7 kg/17 lb) but they are also the ultimate in ruggedness for field use. The 2335, 2336, and 2337 meet or exceed the U.S. military specs for humidity, temperature range, vibration, electromagnetic interference, and shock.

For many applications, internal battery power is often essential. On the other hand, the weight of internal batteries can be a disadvantage if they are rarely needed. In some applications power is always available, since it must be provided to the equipment being tested. Tektronix Portable Oscilloscopes cover the full range of power options. The 200 Series and some 300 Series oscilloscopes have internal batteries. The other 300 Series models and high performance portables, such as the Tektronix 400 Series, are line operated. However, external battery packs are available as accessories for both the 300 Series and the 400 Series.

The 468 combines digital storage, GPIB capability, and a 100 MHz non-storage capability.

Portable General Purpose Instruments

Many of these same factors apply to other instruments besides oscilloscopes. The TM 500 General Purpose Instrument line, for example, has several configurations designed for portability. The TM 515 Traveler Mainframe travels like luggage but works like a lab bench set-up. Although it is attractive and convenient enough to treat as carry-on luggage (it will even go beneath your seat in most airplanes), the TM 515 is designed to take rugged travel. It carries up to five TM 500 Plug-in instruments. Again, relatively light weight, rugged construction, and convenient size are the key to portability.

Plug-ins include: pulse generators, function generators, other signal generators, amplifiers and filters, oscilloscopes and monitors, lab power supplies, digital counter/timers, digital multimeters, special plug-ins, and custom plug-ins.

All of the TM 500 Plug-ins are portable when used with portable TM 500 Mainframes; TM 515 5-compartment Traveler Mainframe, TM 503 3-compartment Mainframe with carrying case or protective cover, TM 504 4-compartment Mainframe with carrying case or protective cover.

In-depth coverage of TM 500 products begins on page 252.

Other Portables

The 490 Series Spectrum Analyzers combine lab performance and ease of operation in a compact, lightweight package. The 492/492P offers a frequency range of 50 kHz to 21 GHz, extendable to 60 GHz with Tektronix external waveguide mixer, and to 220 GHz with commercially available mixers. The 496/496P covers 1 kHz to 1.8 GHz. The 492P/496P are GPIB programmable via IEEE-488 1978 interface.

Still other Tektronix portable instruments meet special requirements far above simple movability. The 1502 and 1503 TDR Cable Testers, for example, are designed to work outdoors in any weather, including pouring rain.

For movement within limited areas, Tektronix SCOPE-MOBILE® Carts and Lab Carts are available in several configurations. A typical setup might include a 400 Series Oscilloscope on the top shelf with two TM 503 Mainframes underneath. These carts are particularly useful for in-plant servicing, school and research laboratories, and similar applications.

| | |
|---------------------|----------|
| Logic Analyzers | page 43 |
| TDR Cable Testers | page 116 |
| Spectrum Analyzers | page 118 |
| SCOPE-MOBILE® Carts | page 344 |

DIGITAL OSCILLOSCOPES AND WAVEFORM DIGITIZERS

STORAGE

Tektronix storage instruments continue to display a waveform after the input signal ceases. The period of retention runs from a few seconds to essentially unlimited storage time depending on the type of storage used.

Storage oscilloscopes allow easy, accurate evaluations of slowly changing phenomena that would appear only as slow-moving dots. They are also needed for viewing rapidly changing nonrepetitive waveforms whose images would otherwise flash across the CRT too quickly to be evaluated. Storage can also reduce the time to photograph scope traces by allowing you to "compose" the picture. Unwanted displays can be erased as many times as necessary before the photograph is taken.

Storage is used in other Tektronix products, too. For terminals, CRT storage provides an economical means of retaining graphic and alphanumeric displays without requiring refresh circuitry. Curve tracers with a storage CRT show a wider range of waveforms. And monitors with storage find a wide variety of applications.

Types Of Storage

Tektronix products use two basic kinds of Storage—digital and CRT type.

The fundamental difference between the digital storage scope and CRT storage is the form of storage. Digital scopes store data representing waveforms in a digital memory; CRT storage scopes store waveforms within the CRT, either on a mesh or special phosphor.

| Type | Analog BW | Max Dig Rate | Vert. Res. | Data Words per Waveform | Max No. Stored Waveform | Useful* Storage BW (SS) | Equip** Stor BW (rep) | Page | Price |
|--------|-----------|-------------------|------------|-------------------------|-------------------------|-------------------------|-----------------------|------|----------|
| 468 | 100 MHz | 25 MHz | 8 Bit | 512 in Alt. 256 in chop | 4 | 10 MHz | — | 242 | \$6270 |
| 5223 | 10 MHz | 1 MHz | 10 Bit | 1024/plug-in | 4 | 100 kHz | 10 MHz | 208 | \$4505 |
| 7854 | 400 MHz | 500 kHz Ext Clock | 10 Bit | Up to 1024 | Up to 40 | 50 kHz | 400 MHz | 177 | \$11,950 |
| 7912AD | 500 MHz | 100 GHz | 9 Bit | 512 | 1 | 500 MHz | 500 MHz | 181 | \$24,800 |
| 7612D | 90 MHz | 200 MHz | 8 Bit | Up to 2048 | Up to 16 | 20 MHz | — | 179 | \$26,400 |

*Useful Storage Bandwidth is a measure of the highest frequency sinewave that can be stored in a single sweep and displayed in a visually useful manner. This is dependent on both the maximum digitizing rate as well as the display reconstruction technique used.
 **Equivalent Storage Bandwidth indicates the highest frequency repetitive signal that can be stored and displayed with less than 3 dB loss of signal amplitude using equivalent time digitizing techniques.

Digital Storage

Digital storage requires digitizing and reconstruction processes. "Digitizing" consists of "sampling" and "quantizing". Sampling is the process of obtaining the value of an input signal at discrete points in time; quantizing is the transformation of that value into a binary number by the analog-to-digital converter (ADC) in the digital scope. You determine how often digitizing occurs by the time base. The time base uses a digital clock to time the analog-to-digital (A/D) conversion and to store the data in memory. The rate at which this happens is the digitizing rate (or sampling rate). Once the data is in the digital memory, it can be read out and reconstructed for displaying or further waveform processing.

Digital storage is typically very easy to use and gives the user crisp, clear displays. Because the data is stored in memory no fading or blooming will occur, and storage time is essentially unlimited. This type of storage is excellent for many applications involving single shot or low repetition signals, or where further signal processing is desired.

Bistable

The bistable-phosphor CRT uses a special phosphor with two stable states: written and unwritten.

The storage mode allows waveforms to be stored and displayed a minimum of several hours (in some cases much longer) or until erased by operator.

Bistable storage is an easy kind of storage to use. It is also usually the most inexpensive. Some principal applications include mechanical measurements, signal comparisons, and data recording. Most bistable phosphor CRT's have a split-screen viewing area which allows each half to be used independently for storage displays. The split-screen feature provides many unique advantages. With this system, a reference waveform can be stored on one half of the screen and the other half can be used to store the effect that calibration adjustments or the insertion of filters, etc, have on circuit operation. If desired, this technique can be used where the reference portion operates in the stored mode and the other half of the display, operating in the nonstored mode, monitors an external input.

An example of the usefulness of the split-screen feature is in speech therapy. The normal speech pattern is recorded on the upper half of the storage screen and the patient's attempts to match this pattern are recorded on the lower half. With split-screen operation, the lower half showing the trial waveform can be erased as many times as desired without affecting the stored information on the upper screen.

Variable Persistence

Variable persistence storage allows a continuous gradation between the bright written level and the dark reference.

The variable persistence mode also allows for the selection of the time a stored image will be retained. The storage persistence can be adjusted so the entire waveform can be viewed, yet the stored trace fades from view just as the new waveform is being plotted. With the save feature, an entire display can be stored for further analysis if desired.

CRT STORAGE PERFORMANCE

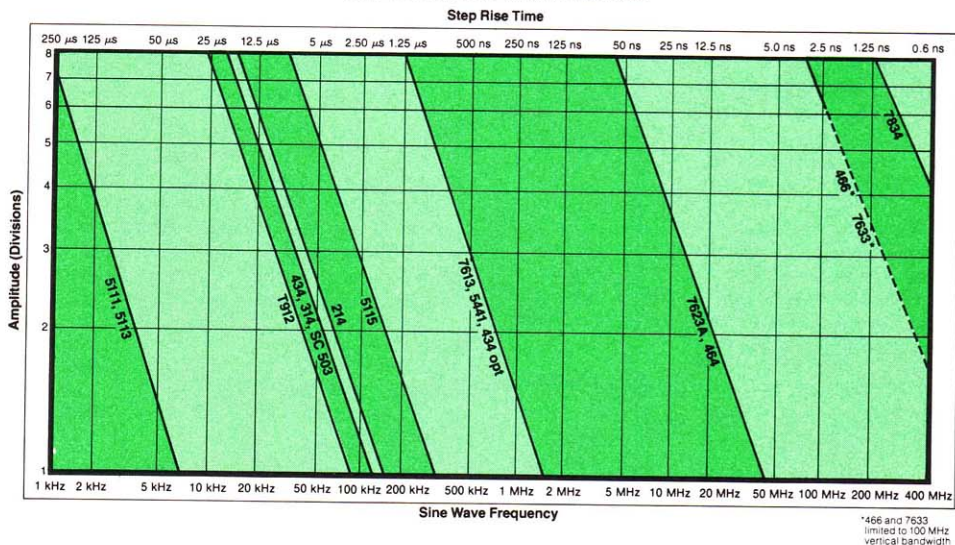

CRT STORAGE OSCILLOSCOPES
(in order of Stored Writing Speed)

| Product | Stored Writing Speed | View Time | Type of Storage | Bandwidth** | Minimum Deflection Factor | Number of Traces | Delayed Sweep | Plug-in | Page | Price |
|---------|--------------------------|--------------------|---------------------------|-------------|--|-------------------|---------------|---------|------|----------|
| 7834 | 5500 div/μs | 30 s †† | Fast Variable Persistence | 400 MHz | 20 mV/div at BW 10 mV/div at 325 MHz | Up to 4 | X | X | 169 | \$11,000 |
| | 776 div/μs | 30 min minimum | Fast Bistable | | | | | | | |
| | 12 div/μs | 30 s †† | Variable Persistence | | | | | | | |
| | 0.2 div/μs | 30 min minimum | Bistable | | | | | | | |
| 466 | 3000 div/μs | 15 s †† | Fast variable persistence | 100 MHz | 5 mV/div at BW | Up to 2 | X | | 244 | \$6385 |
| | 3 div/μs | 15 s †† | Variable persistence | | | | | | | |
| 7633 | 2200 div/μs | 30 s †† | Fast variable persistence | 100 MHz | 5 mV/div at BW 10 μV/div 1 mA/div | Up to 4 | X | X | 172 | \$7295 |
| | 400 div/μs | 30 min minimum | Fast bistable | | | | | | | |
| | 3 div/μs | 30 s †† | Variable persistence | | | | | | | |
| | 2 div/μs | 30 min minimum | Bistable | | | | | | | |
| 7623A | 150 div/μs | 30 s †† | Fast variable persistence | 100 MHz | 5 mV/div at BW 10 μV/div 1 mA/div | Up to 4 | X | X | 172 | \$5585 |
| | 50 div/μs | 30 min minimum | Fast bistable | | | | | | | |
| | 0.5 div/μs | 30 s †† | Variable persistence | | | | | | | |
| | 0.03 div/μs | 30 min minimum | Bistable | | | | | | | |
| 464 | 110 div/μs 0.5 div/μs | 15 s †† 15 s †† | Fast variable persistence | 100 MHz | 5 mV/div at BW | Up to 2 | X | | 244 | \$5165 |
| 7613 | 5 div/μs | 1 hr | Variable persistence | 100 MHz | 5 mV/div at BW 10 μV/div 1 mA/div | Up to 4 | X | X | 174 | \$4680 |
| 5441 | 5 div/μs | 1 hr | Variable persistence | 50 MHz | 5 mV/div at BW 10 μV/div 0.5 mA/div | Up to 8 | X | X | 211 | \$4060 |
| 434 | 5 div/μs | 4 hr | Bistable split screen | 25 MHz | 10 mV/div at BW 1 mV/div | Up to 2 | | | 246 | \$4400 |
| 5115 | 0.8 div/μs | 10 hr | Bistable split screen | 2 MHz | 1 mV/div at BW 10 μV/div 0.5 mA/div | Up to 8 | X | X | 215 | \$2235 |
| 214 | 0.5 div/μs | 1 hr | Bistable | 500 kHz | 10 mV/div at BW 1 mV/div | Up to 2 | | | 248 | \$2100 |
| 314 | 0.4 div/μs | 4 hr | Bistable | 10 MHz | 2 mV/div at BW | Up to 2 | | | 247 | \$3345 |
| SC 503† | 0.4 div/μs | 4 hr | Bistable | 10 MHz | 1 mV/div at BW | Up to 2 | | | 287 | \$3150 |
| DM 64 | 0.25 div/μs | 1 hr | Bistable | 10 MHz | 1 mV/div at BW | Up to 2 | | | 251 | |
| T912 | 0.25 div/μs | 4 hr | Bistable | 10 MHz | 2 mV/div at BW | Up to 2 | | | 249 | \$1890 |
| 5113 | 0.2 div/μs | 10 hrs | Bistable split screen | 2 MHz | 1 mV/div at BW 10 μV/div 0.5 mA/div | Up to 8 dual-beam | X | X | 215 | \$2970 |
| 5111 | 0.02 div/μs | 10 hr | Bistable split screen | 2 MHz | 1 mV/div at BW 10 μV/div 0.5 mA/div | Up to 8 | X | X | 214 | \$2100 |

**Bandwidths are real time. Sampling plug-ins that extend bandwidths to 14 GHz are available for most mainframes.

†The SC 503 is an oscilloscope that must be plugged into a TM 500/TM5000 Mainframe for operation. Please turn to page 252 for more information.

††View times are at full stored display intensity. They may be increased by using reduced intensity in the save display mode.

Applications for variable persistence storage include real time, spectrum analysis, time-domain reflectometry, sampling and other measurements which require slow sweep displays. For fast repetitive sweeps, the storage persistence can be set so multiple traces are displayed before the first trace fades from view. Then you can view changes in signal response with changes in circuit conditions, time, or adjustments. This method can also be used to provide display integration so that only the coincident portions of a repetitive signal are displayed. Any aberration or jitter not common to all repetitive traces will not be stored

or displayed. Low repetition rate, fast rise time signals that are not discernible on conventional CRT's can be easily viewed.

This type of storage provides the best display when storing displays with varying intensities, such as delayed sweep or with Z-axis intensity modulation. Variable persistence storage provides very good displays for photographs due to the high contrast between dark background and bright waveforms.

Fast Transfer

Fast transfer storage uses a tube with a special intermediate mesh target. This target, which is optimized for speed, captures the waveform and then transfers it to a slower, longer-storing electrode. The second target can be designed to offer bistable or variable persistence modes, in combination with the transfer mesh or by itself.

Several Tektronix Oscilloscopes use this combination of capabilities to provide unique multimode storage. By front-panel controls, users of these instruments can select the operating mode suited to the specific measurement situation.

CATHODE-RAY TUBE PHOSPHOR DATA

Human Eye Response

An important factor in selecting a phosphor is the color or radiant energy distribution of the light output. The human eye responds in varying degrees to light wavelength from deep red to violet. The human eye is most sensitive to the yellow-green region; however, its responsiveness diminishes on either side in the orange-yellow area and the blue-violet region. The eye is not very receptive to deep blue or red.

If the quantity of light falling on the eye is doubled, the brightness "seen" by the eye does not double. The brightness of a color tone as seen is approximately proportional to the log of energy of the stimulus.

The term **luminance** is the photometric equivalent of brightness. It is based on measurements made with a sensor having a spectral sensitivity curve corrected to that of the average human eye. The SI (international metric standard) units for luminance are candelas per meter squared, but the English footlamberts are still used extensively in the U.S. One footlambert = 3.43 candelas/m². The term **luminance** implies that data has been measured or corrected to incorporate the CIE standard eye response curve for the human eye. CIE is an abbreviation for "Commission Internationale de L'Eclairage" (International Commission on Illumination). The luminance graphs and tables are therefore useful only when the phosphor is being viewed.

Phosphor Protection

When a phosphor is excited by an electron beam with an excessively high current density, a permanent loss of phosphor efficiency may occur. The light output of the damaged phosphor will be reduced, and in extreme cases complete destruction of the phosphor may result. Darkening or burning occurs when the heat developed by electron bombardment cannot be dissipated rapidly enough by the phosphor.

The two most important and controllable factors affecting the occurrence of burning are **beam-current density** (controllable with the Intensity, Focus, and Astigmatism controls) and the length of **time** the beam excites a given section of the phosphor (controllable with the Time/Div control). Of the total energy from the beam, 90% is converted to heat and 10% to light. A phosphor must radiate the light and dissipate the heat, or like any other substance, it will burn. Remember, burning is a function of intensity and time. Keeping the intensity down or the time short will save the screen.

Selecting A Phosphor

The catalog description of each oscilloscope indicates the phosphor normally supplied or offered as an option. Special phosphors are available for applications which require different characteristics. For example, P11 is excellent for waveform photography but due to its short persistence it is not well suited for applications requiring visual observation of low-speed phenomena. For more specific information regarding the best-suited phosphor for your particular applications, please confer with your Tektronix Sales Engineer, Representative or Distributor. They know the factors that must be considered in selection of a phosphor for any given application.

Phosphors are rated in several parameters, such as color of fluorescence or phosphorescence, decay, etc. The table below describes the more commonly used phosphors.

COMPARATIVE CRT PHOSPHOR DATA

| Phosphor | Fluorescence | Phosphorescence Where Different from Fluorescence | Relative Luminance ¹ | Relative Photographic Writing Speed ² | Decay | Relative Burn Resistance | Comments | Ordering Information Option |
|----------|-----------------|---|---------------------------------|--|-----------|--------------------------|--|-----------------------------|
| P1 | Yellowish-green | — | 50% | 20% | Medium | Medium | Replaced by P31 in most applications | Special order |
| P4 | White | — | 50% | 40% | Med-Short | Medium high | Television displays | 74 |
| P7 | Blue | Yellowish-green | 35% | 75% | Long | Medium | Long decay, double-layer screen | 76 |
| P11 | Purplish-blue | — | 15% | 100% | Med-Short | Medium | For photographic applications | 78 |
| P31 | Yellowish-green | — | 100% | 50% | Med-Short | High | General purposes, brightest available phosphor | 80 |
| P39 | Yellowish-green | — | 27% | NA ⁴ | Long | Medium | Photographic applications | 40 |
| P43 | Yellowish-green | — | 40% | NA ⁴ | Medium | Very High | High current density phosphor | Special order |
| P44 | Yellowish-green | — | 68% | NA ⁴ | Medium | High | Bistable storage | |
| P45 | White | — | 32% | NA ⁴ | Medium | Very High | Monochrome TV displays | |

¹Measured with Tektronix J16 Photometer and J6523 Luminance Probe which incorporates a CIE standard eye filter. Representative of 10 kV aluminized screens. P31 as reference.

²P11 as reference with Polaroid 410 film. Representative of 10 kV aluminized screens.

³Low level lasts over one minute under conditions of low ambient illumination.

⁴Not available.

KEY SPECIFICATIONS AND FEATURES
for oscilloscopes and related equipment

AMPLIFIER CONSIDERATIONS

Rise Time and Bandwidth

Two vital capabilities generally sought in an oscilloscope are sufficient bandwidth and adequate rise time.

Although rise time is usually the more important parameter when working with faster waveforms, signal bandwidth is commonly specified for lower speeds. The frequency response of most scopes is designed so that there is a constant that allows you to relate the bandwidth and rise time of the instrument. This constant is 0.35 and the rise time and bandwidth are related by this approximation:

$$T_r = \frac{0.35}{BW}$$

A simple way to apply the formula is:

$$T_r \text{ (nanoseconds)} = \frac{350}{BW \text{ (Megahertz)}}$$

For the Tektronix 2200 Series instruments with a bandwidth of 60 MHz, the rise time is 5.8 nanoseconds.

Bandwidth is defined as the frequency range in which signals are handled with less than a 3 dB loss compared to midband performance. Since modern oscilloscopes work well at low frequencies down to dc, bandwidth here commonly refers to the highest frequency which can be displayed with a 3 dB or less error.

Most oscilloscope designs make use of gradual roll-offs at the high-frequency end, so in many cases a scope will be useful far beyond its specified bandwidth. Waveshapes may be altered and amplitudes reduced somewhat.

In terms of rise time, scopes ideally should have a vertical system capable of responding at least five times as fast as the fastest applied step signal (thus having a rise time less than 1/5 as great). In such a case, the rise time of the signal indicated on the scope will be in error by less than 2 percent.

Using the 1/5 and 0.35 factors together, the minimal requirements for scope bandwidth for accurate rise time measurements can be estimated using the following rule of thumb:

$$\text{Bandwidth (minimal)} \approx \frac{1.70}{\text{Fastest Rise Time}}$$

Very accurate absolute rise time measurements are not always important. When simply comparing the rise times of two signals, scopes with a rise time equal to the rise time of the signals applied are usually considered adequate.

Besides indicating bandwidth for the vertical channel, many oscilloscope specifications also include a bandwidth figure for the horizontal and trigger channels.

Bandwidth and rise time figures also apply to many other Tektronix instruments. Signal sources, probes, amplifiers, TDR systems and many other test instruments are characterized in part by rise time. Frequency response figures are given for portable patient monitors, spectrum analyzers and many TV products. The specifications will indicate values where these figures are relevant.

Sensitivity (Deflection Factors)

Although sensitivity specifications are most often associated with oscilloscope vertical channels, specifications can also be provided for horizontal channels and trigger circuits with external inputs. Similarly, various other instruments may have a sensitivity specification relating minimum input level to some function or output level.

Sensitivity, in the case of oscilloscopes, refers to the input needed to produce a stated deflection of the spot on the CRT. Specifications typically are given in millivolts per centimeter or division.

At a given state of the art, sensitivity is a trade-off with bandwidth. The small amount of noise in even the best input circuit will mask signals which are too weak. Raising the bandwidth increases the noise picked up by the amplifiers, requiring more of a signal to create a clear display.

As a consequence of this relationship, many high-sensitivity scopes provide bandwidth-limiting controls to allow you to make better low-level, moderate frequency measurements. For these and other models, a set of sensitivity specifications may be given for limited frequencies as well as over the full range.

Many times, external noise will be the problem. Differential amplifiers are often used to lessen the effects of external noise and common-mode signals, thus improving the useful measurement sensitivity range.

Differential, Balanced, or Push-Pull Inputs

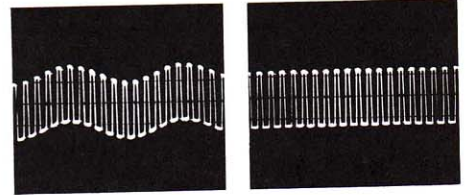

Differential or balanced amplifiers provide a feature beyond mere accommodation of push-pull signals: they have the ability to cancel or reject, to a high degree, any signal components equal in amplitude and phase that appear at both inputs. Such amplifiers provide a simple and accurate means of measuring the difference between two signals. They also provide a means of rejecting most unwanted signal components common to both inputs, such as power line "hum."

Multiple Inputs

It is quite often useful to be able to view any one or several of a number of input signals without disturbing connections to the oscilloscope. Several types of multiple-input amplifiers which display more than one signal on the same CRT display are available.

Common applications include input-output comparisons, checking a signal against a standard or working with complex circuits.

Dual-Beam and Dual-Trace

Two techniques, dual-trace or dual-beam circuitry, are commonly used for creating two traces on a single CRT. The dual-trace scope incorporates electronic switching to alternately connect two input signals to a single deflection system. The dual-beam scope, however, has two independent deflection systems within its CRT. (Some models do share horizontal systems, though.) There are distinct advantages to both dual-beam and dual-trace scopes. A dual-beam scope can display two input signals separately and simultaneously. Therefore, it can show two nonrecurrent signals of short duration. Also, models with independent horizontal deflection can display nonrecurrent signals on different time bases.

The principal advantages of dual-trace scopes are lower cost and intrinsically better comparison capabilities. This comes from using a single horizontal amplifier and one set of deflection plates. On the other hand, since a transient event might occur on one input channel while the beam is tracing the other, dual-trace scopes are not recommended for viewing fast one-shot phenomena.

Extension of the dual-trace principles has produced newer multiple-trace oscilloscopes capable of displaying up to eight traces.

Tektronix Logic Analyzers display up to 16 channels of timing data, and can acquire up to 52 channels of state information.

TIME BASES

Sweep Rates and Sweep Types

Except in special cases, oscilloscopes have built-in sawtooth sweep generators for producing constant-speed horizontal beam deflection. In early scopes, these generators ran continuously and horizontal calibration was based on their repetition frequency. In most modern scopes, sweeps are calibrated in terms of a direct unit of time for a given distance of spot travel across the screen; hence the term, "time base."

This technique permits:

1. Direct measurement of time between events.
2. Viewing and measuring small portions of pulse trains.
3. Viewing and measuring random or aperiodic events.
4. Viewing and measuring single nonrecurrent events.

Distances representing time are measured on the scope's graticule, the ruled scale built into the display. The internal graticule built inside the CRT face on modern scopes is preferable, as it eliminates parallax.

A major graticule division may be an inch, centimeter or some other length. Some instruments have different distance-units for the vertical and horizontal scales. Graticules often have small markings which subdivide the major divisions to assist in making accurate measurements. Such subdivisions should not be interpreted as the distance unit in a specification.

Strictly speaking, sweep specifications are rates properly expressed as time/length. However, the term *sweep speed* (implying length/time) is often used synonymously.

Relating Sweep Rates, High Frequencies and Rise Times

The appropriate sweep rate for frequency-specified measurements is based on the nature of the test. Given a moderate frequency, a sweep is usually considered adequate if it is capable of displaying one cycle across the full horizontal scale. At high frequencies, however, scopes seldom have sweeps that fast. To measure rise time as accurately as possible, a step signal (squarewave, rectangular pulse, etc) should occupy most of the full vertical scale, and the rising portion of the signal should be displayed at nearly a 45° slope. This objective can be met only if the fastest sweep is able to move the beam a horizontal distance nearly equal to the full vertical scale in a time interval equal to the rise time of the vertical deflection system. Because of the compounding difficulties and cost of providing extremely fast sweeps which are both linear and accurate, this goal must be tempered somewhat in scopes having the very best vertical deflection system rise time capabilities.

In some cases rise time measurements are not made to determine actual rise time, but are done to decide whether certain limits are met or exceeded. In such cases, an adequate comparison with a standard signal of known rise time can usually be made even with a sweep that provides a fairly steep display, given that the vertical deflection system rise time is good enough.

Delaying/ Delayed Time Bases

Delaying-sweep measurements use two linear calibrated time bases. The first timebase, commonly called the delaying sweep, allows the operator to select a specific delay time. When this time is reached, the second time base, called the delayed sweep, starts. The delayed sweep is typically set a decade or two faster than the delaying sweep and therefore offers additional resolution. The combination of these two time bases also offers increased accuracy of time interval measurement.

Digital Time Displays



You can make delay and interval time measurements with digital ease on several Tektronix Oscilloscopes. The DM44 option for the 400 Series allow you to read the delay time, interval frequency, or temperature right from an LED readout, with no calculation or interpolation required. The 7B10, 7B15, 7B85 and 7B80 Plug-ins for 7000 Series Oscilloscopes provide Δ time (dual-delayed sweep) measurements. With this feature, both ends of the selected interval which can be independently positioned on the trace are shown by intensified regions. The time interval between those points is shown on the screen using the 7000 Series CRT readout capability.

Sampling

Sampling is a powerful technique for examining very fast repetitive signals. It is similar, in principle, to the use of stroboscopic light to study fast mechanical motion. Progressive samples of adjacent portions of successive waveforms are taken; then they are "stretched" in time, amplified by relatively low-bandwidth amplifiers, and finally shown, all seemingly at one time, on the screen of a cathode-ray tube. The graph thus produces a replica of the sampled waveforms. The principal difference in appearance between displays made by sampling techniques and conventional displays is that those made by sampling are comprised of separate segments or dots. This technique is limited to depicting repetitive signals, since no more than a portion of the signal is captured and displayed each time the signal recurs.

The sampling method, however, provides a means of examining fast-changing signals of low amplitude that cannot be examined in any other way. The system is capable of resolving events that occur in less than 30 picoseconds on an "equivalent" time base of less than 20 picoseconds per division and less than 5 mV of peak amplitude.

Tektronix uses the random sampling technique which differs from conventional sampling because it does not require a delay line or pretrigger for lead time to be visible in the display. The benefits afforded by this feature are:

1. Signals with no source of pretrigger can be observed.
2. The inherent rise time limitation of signal delay lines is eliminated.
3. It is no longer necessary to work into the 50 Ω characteristic impedance of a delay line, so high impedance can be retained.
4. External triggers may occur before, coincident with, or after the displayed signal, with lead time still visible in the display.
5. Display time jitter otherwise caused by pretrigger-to-signal jitter is eliminated.

SIGNAL PROCESSING SYSTEMS

CONTENTS

| | |
|--------------------------------------|-----|
| System Products | 144 |
| Software | 145 |
| Mini-Computer Based Systems | 146 |
| Desktop Computer Based Systems | 147 |



WP2252 (7912AD-Based Computer System)



WP1310 (7854-Based Desktop Computer System)

Precise automatic waveform measurements for demanding applications in research, design, manufacturing and quality assurance

Automatically save hours, days, even months of work.

Tektronix Signal Processing Systems are specially designed to handle the increasingly complex, expensive, and time-consuming task of waveform characterization.

They're the first measurement systems to offer all the power and flexibility of oscilloscope acquisition, coupled with fully automatic analysis. They're the first systems to feature signal processing software with extensive control over instrumentation,

waveform manipulations, and graphic display. And they're the first to provide system compatibility that allows configuration for many types of test and measurement applications.

With Tektronix Signal Processing Systems you concentrate on test results, not test procedures. There are no human-eye interpretations, hand processing, or complex statistical graphing. Tektronix Systems automatically capture the signals you need, make the measurements you want, then display, store, and document your solutions.

This means work that used to take hours, now takes only minutes. System automation saves you time and money by greatly increasing your productivity. Projects not only get completed on schedule, they get completed on budget.

Plus, system automation gives greater measurement accuracy and accountability on your finished product. Since there's less operator involvement in measurements, there's less chance of human error.

From today's research and development tasks to tomorrow's production testing, Tektronix Systems give you all the capabilities needed to characterize your waveforms quickly, efficiently, and automatically.

For measurement solutions you can't beat the SYSTEM.

SPS AUTOMATION . . .

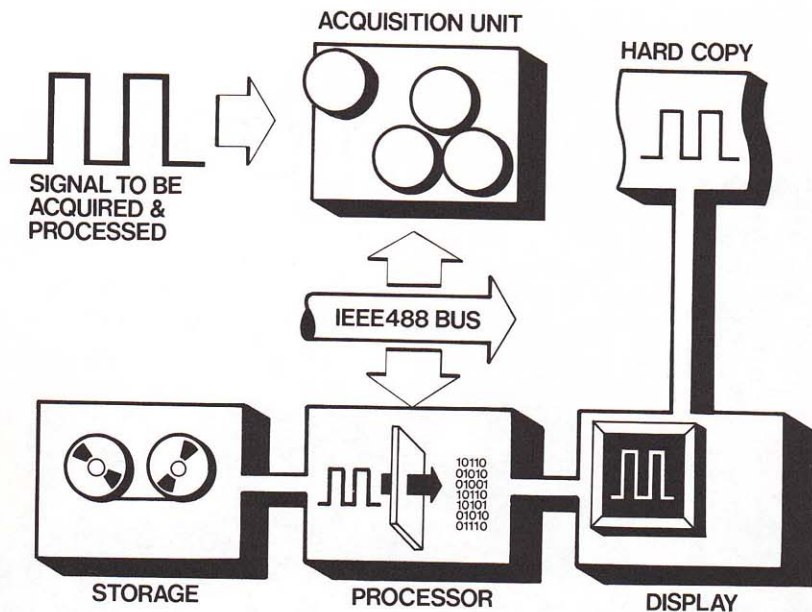

FIVE MAJOR SYSTEM COMPONENTS AND TEK'S COMPREHENSIVE SOFTWARE MEET YOUR MEASUREMENT NEED

Acquisition, built around TEKTRONIX GPIB Waveform Digitizers and 7000 Series Oscilloscope Plug-ins, captures analog data, converts and stores it in a digital format acceptable to the system processor.

Processor, either minicomputer or desk-top computer, controls the system, accepts the digitized data, and then performs the needed mathematical calculations and operations.

Mass Storage, in the form of disk or magnetic tape, keeps a log of the processed data and also stores the test programs.

Display, including graphic terminal and **Hard copy units**, provides both alphanumeric and graphic presentation of data and permanent documentation.

Software, specially developed for ease of use with TEKTRONIX Signal Processing Systems, controls all other system components and performs the desired computations. Commands are high-level BASIC and accessible through a standard terminal keyboard.

A WIDE RANGE OF SYSTEM PRODUCTS PROVIDES THE SOLUTIONS YOU NEED

Signal acquisition. Fast or slow, transient or repetitive.

The growing family of GPIB compatible 7000 Series Waveform Digitizers provides a broad range of acquisition capabilities. They offer the ability to analyze signals ranging from seconds to picoseconds in duration, and risetimes to 25 ps. Plus, all are compatible with a broad range of 7000 Series Plug-ins.

7912AD*

For high-speed transient signal acquisition, the 7912AD Programmable Digitizer has the capability to capture signals in the millisecond to subnanosecond range with a bandwidth of up to 500 MHz.

7612D*

For medium-speed signals, the 7612D Programmable Digitizer offers dual channel acquisition, selectable sampling rates within records, and pre- and post-triggering. With the 7612D you can capture transient signals from seconds to sub-microseconds in duration with high resolution.

7854*

For fast, repetitive signals, the 7854 Oscilloscope is ideal when configured in a system. The 7854 features an on-board microprocessor. This instrument provides the system with the capability to acquire high speed signals with rise times to 25 ps.

*Digital Mainframes Section for details.

System controllers dedicated to speed and precision.

TEKTRONIX Signal Processing Systems are divided into two major processor families: the minicomputer family, and the desktop computer family.

The Tektronix minicomputer systems, built around DEC PDP11 compatible controllers, are designed to handle large amounts of data. They offer flexibility in peripheral selection, processing speed, and up to 128k words of memory space. Plus, the software support is specially developed for waveform manipulations, array processing and display efficiency.

The desktop computer systems are built around the 4052 Desktop Computer—one of the most powerful analytical performers available today. Its built-in extended BASIC software is complemented by special ROM packs featuring commands most often used in signal processing applications.

Wide-ranging system peripherals for full documentation and display.

TEKTRONIX Signal Processing Systems provide the best in display—the 4010-1 or the 4052 graphic screen. These terminals provide an excellent medium for displaying graphic and alphanumeric information with high resolution. In addition, a wide range of system peripherals is available, including graphic plotters, hard copy units, disk and magnetic tape storage devices.

NEW

Introducing the new 1360P/S.

As part of the on going commitment to supply complete system solutions, a new high performance multiplexer is now available either as part of an SPS System or to be integrated into your own system.

The 1360 is a microprocessor-based GPIB compatible system instrument that can be used to multiplex electrical signals at bandwidths up to 250 MHz. It includes two separate chassis: the 1360P Programmable Switch Controller and the 1360S Switch Matrix. Up to four 1360S Switch Matrix units may be operated by one 1360P. With one 1360S one may multiplex 1 output with 33 inputs, 2 ganged outputs with 17 inputs, or 4 ganged outputs with 9 inputs. With four 1360S units these numbers increase so one may multiplex 1 output with 129 inputs, 2 ganged outputs with 65 inputs, or 4 ganged outputs with 33 inputs.

Total Support

Complete details and application consultation is available through your local Tektronix Sales Office. SPS Specialists and Application Engineers stand ready to answer all your system questions.

The next logical step

ANY SYSTEM IS ONLY AS GOOD AS ITS SOFTWARE SPS SYSTEMS OFFER THE BEST SOFTWARE AVAILABLE

TEK SPS BASIC is a comprehensive, general purpose programming language with enhancements for instrument control and waveform processing. Modular in design, it provides an optimum balance between flexibility, space efficiency, and computing power. Yet it retains the "easy-to-learn, easy-to-use, easy-to-remember" character of traditional BASICs. This makes it an ideal tool for beginning users as well as expert programmers.

TEK SPS BASIC runs on the TEKTRONIX CP1164X Instrument Controller, on the PDP11/23 Computer, or on any Digital Equipment Corporation PDP-11 minicomputer. It consists of a Resident Monitor and an expandable library of over 100 non-resident commands. This lets you configure a software system to meet your unique measurement needs.

It's ready to use. TEK SPS BASIC requires a minimum system consisting of a controller with one hard-disk drive or two flexible-disk drives. Commands can be added to the system from the disk as needed to provide maximum space efficiency in available memory.

Named files can be accessed by TEK SPS BASIC on hard or flexible disk, or magnetic tape and information can be read from files either sequentially or randomly. BASIC commands give you complete file management capability. Files are compatible with DEC's RT11 operating system.

Comprehensive graphics permit waveform plots and X-Y plots between waveforms. Either can be done with single commands. The output is complete with scaled and labeled axes and can be hard-copied to paper.

TEK SPS BASIC data-logging capabilities let you turn tedious and repetitive measurements into automated procedures. Program control can eliminate human intervention, reduce errors, and give you time to concentrate on test results.

Better than seven-digit precision means much higher resolution than possible in conventional oscilloscope measurements. Special data structures retain both numeric and literal information associated with a given waveform. These waveform structures, as well as numeric arrays or portions of numeric arrays, can be operated on arithmetically as easily as can simple numeric variables.

PDP and DEC are registered trademarks of Digital Equipment Corporation

Advanced Signal Processing

Waveforms can be integrated, differentiated, convolved, correlated, and fast Fourier transformed. Also, polar conversions can be performed.

Flexible I/O

Information can be read or written in ASCII or binary. ASCII may be used for display on a terminal or to store information for use by another software system. Binary can be used for storing large information blocks for later processing by TEK SPS BASIC. File may be structured either serially or by random access.

GPIB

With BASIC commands, you can control multiple IEEE-488 interfaces at any level, from setting individual data lines to reading in entire arrays with a single command. The GPIB feature, which can be deleted from the BASIC system to save memory, is integrated with the Resident Monitor to make GPIB control commands more space economic. A high level GPIB driver is also available to facilitate programming for those not thoroughly familiar with GPIB.

There is also available a versatile GPIB software module for RSX11-M. This requires special quotation from SPS Marketing.

Software Maintenance

Customers receive a periodic newsletter containing programming hints and responses to user questions. Reported system errors can usually be corrected by customer-applied "patches." These short code sequences are published in the newsletter with instructions for adding them to established systems. Specific problems encountered by customers which appear to be caused by software defect may be addressed by submitting a Software Performance Report (SPR) which will be responded to in writing. (Category B support.)

ORDERING INFORMATION

SOFTWARE PACKAGES

| | |
|---|--------|
| CP57000 TEK SPS BASIC (Monitor) .. | \$5475 |
| CP57001 Signal Processing | \$1285 |
| CP57002 Graphics | \$975 |
| CP57003 R7912 Transient Digitizer Driver | \$1445 |
| CP57004 Digitizing Oscilloscope (DPO) Driver | \$865 |
| CP57005 DPO Envelope Command | \$350 |
| CP57006 7912AD Programmable Digitizer Driver | \$875 |
| CP57007 High Level Support | \$580 |
| CP57008 Assembly Level Support | \$2890 |
| CP57009 GPIB High Level Driver | \$750 |
| CP57010 7612D Special Commands | \$300 |

Extended memory capability is offered in V02XM (CP575XX) software permitting operations which involve large arrays of data to be manipulated in computers having up to 128k memory, with memory management. Prices are the same as V02 modules, except CP57500 \$7125

For additional information or a demonstration of the TEK SPS BASIC software family, call the Tektronix Sales Office in your area and ask for your SPS Specialist.

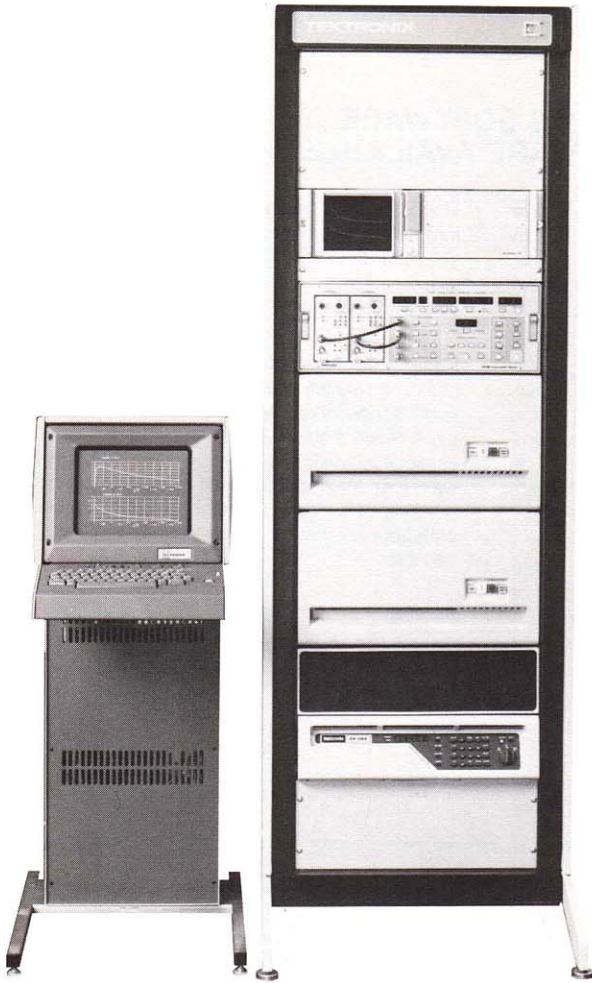

The WP3201 is one of the many configurations for the minicomputer-based systems.

Systems

Tektronix Minicomputer-based systems offer combinations of Tektronix Waveform Digitizing instruments, flexible instrument controllers, and the most powerful waveform (array) processing BASIC software available on the market. These systems are tailored for medium and large scale experiments and for use in areas where medium or high power, dedicated systems are best suited to the task. System versatility and easy-to-use software allow for a wide variety of tasks to be performed at a multi-purpose test area. Large amounts of data storage and waveform analysis are manageable under the TEK SPS BASIC operating system which handles full arrays of data as easily as single-valued variables.

Instrument control and data communication are accomplished over the IEEE-488 (GPIB) bus, allowing for easy expandability. Multiple instruments performing different functions may be added as needs expand or change. Control or data busses other than GPIB may be added by the user and controlled by TEK SPS BASIC software.

Mass storage includes either floppy or hard disk systems for operating system, non-resident commands, data files and user program storage. Hard copy capability may be added by ordering the Tektronix 4631 option to these systems.

Measurement requirements and technologies are changing rapidly in the dynamic fields of physics, optics, chemistry, biology, and electronics. Improved bandwidths, sensitivities, triggering circuits, and storage capabilities have done a great deal to increase the value of oscilloscopes as general-purpose measurement equipment in these fields. But in more and more applications scope measurements are being supplemented by computations to get the information in a form that is easy to interpret.

Some Applications

The development and manufacturing of today's increasingly complex electronic devices require extensive analysis of the signals these devices generate and transmit. For example, performance and calibration of high density cartridge disks can be characterized using Tektronix Signal Processing Systems — providing accurate, reliable results in seconds. Other components, such as semiconductors and optical fibers, have benefited from Tektronix Signal Processing System analysis.

Evaluating equipment designed to be used in hostile environments is a growing challenge for today's test and measurement technology. In the area of lightning effects, Tektronix Signal Processing Systems are used because they can capture randomly occurring events generated in such hostile environments. Other examples include shock and vibration testing, and electromagnetic pulse testing.

High performance instrumentation and waveform analysis have always been required in research and development for the discovery and quantification of new phenomena. With acquisition bandwidths up to 14 GHz, Tektronix Signal Processing Systems are ideally suited for such fields as laser-related research, fusion research, biochemistry, ballistics and ultrasonics.

Warranty

Systems defined as "WP" Systems are installed at the user's site free of charge. On-site warranty is for 90 days from date of system start-up, or 120 days from date of shipment, whichever is shorter. Individual instruments are warranted for one year at a Tektronix Service Center. Post-warranty service is available on a normal charge basis, or system components may be sent to a Service Center for repair.

AVAILABLE MINI-COMPUTER-BASED SYSTEMS

| | | |
|-----------------------|------------------|--------|
| | 7912AD | 7612D |
| PDP 11/23 Floppy Disk | WP2252 | WP3202 |
| CP1164X/Hard Disk | WP2251 w/options | WP3201 |

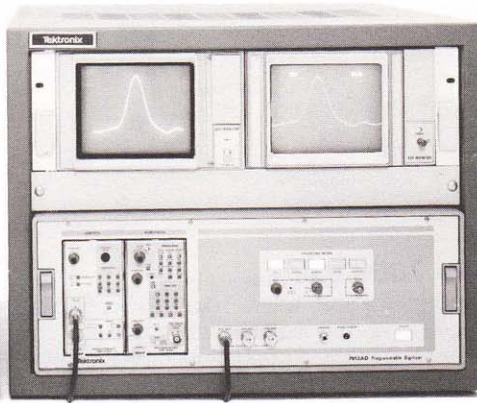

The WP2110 is one of three desktop computer-based systems.

Systems

Tektronix Desktop Computer-based Systems offer combinations of Tektronix Waveform Digitizing instruments and the 4052 Graphic Computing System. These systems are tailored especially for single user, small and medium scale experiments and for use in areas where medium power, dedicated, self contained systems are best suited to the task. Each system contains the flexibility to be easily moved between areas or to perform a variety of tasks at a multi-purpose test bench.

Instrument control and data communication are accomplished over the IEEE-488 (GPIB) bus, allowing for easy expandability. Multiple instruments of the same type or GPIB-interfaced instruments performing different functions may be added as needs change. Data communication with external intelligence for additional flexibility is available via an RS-232C port. Hard-copy capability from the display may be added by ordering the TEKTRONIX 4631 option to these systems. Raw and processed data and user programs may be stored using the integral magnetic tape, or the TEKTRONIX 4907 flexible disk File Manager may be ordered to supplement the system.

Desktop Graphic Computer and Display

The TEKTRONIX 4052 Graphic Computer has gained wide acceptance as a powerful data processing tool for system applications. For rapid calculations this desktop computer contains a fast processor with microcoded floating point.

The 4052, with state-of-the-art graphics capability, can provide hard copies of any combination of text and high density graphics via an optional hardcopy unit. For peripheral support the 4052 uses the GPIB and RS-232C to interface with additional instruments as your needs require. And with memory expandable to 64k bytes, the 4052 can handle lengthy programs and large amounts of data.

Desktop Computer Software

4052 software is an easy-to-learn enhanced form of BASIC which provides the simplicity desired by the beginner and the flexibility and power required by the experienced programmer. Device independent keywords make programming input and output operations easy. Fast matrix functions are also part of 4052 BASIC. Special ROM Packs provide 15 commonly used waveform processing functions—from the location of waveform maximums and minimums to fast Fourier transforms. And Tektronix supports the software of the 4052 with an extensive applications software library—including mathematics, statistics and graphics packages—which aids the user in solving measurement problems from modeling to final report generation.

For graphic display control, an entire set of commands allows graphic displays to be created on the 4052. For example, one ROM Pack command provides the ability to display a complete array of data with a single statement.

Broad Support Completes the Package and Assures You of Continuing Value

From signal acquisition through final display on-going support guarantees you the most value for your investment dollar. The many support programs available are yours as a part of your system purchase.

HANDSHAKE is a newsletter forum for users of TEKTRONIX programmable instruments and systems. Published quarterly, HANDSHAKE has articles of interest concerning applications of measurement and analysis techniques.

SPS PROGRAMMING UPDATE is published periodically and sent to users of TEKTRONIX Signal Processing Systems. It contains information to help maintain software and firmware system components. It also contains useful programming hints and software and firmware product information.

Most important of all, a staff of Signal Processing Systems Specialists, located at various offices, stand ready to assist you in all aspects of system specification and performance.

Tektronix complete training is offered in TEK SPS BASIC software and the operation of signal acquisition and processing systems.

AVAILABLE DESKTOP COMPUTER-BASED SYSTEMS

| | | | |
|------|--------|--------|--------|
| | 7854 | 7912AD | 7612D |
| 4052 | WP1310 | WP2110 | WP3110 |

For complete information on SPS Systems and Digitizers described, contact your SPS Specialist

for data sheets and descriptive literature through your nearby Tektronix Sales Office.

Tektronix offers training classes in TEK SPS BASIC Software and the operation and maintenance of typical signal acquisition and processing systems. For further training information, contact your local Sales Office or request a copy of the Tektronix Customer Training Catalog on the return card.

7000 SERIES INSTRUMENTS

CONTENTS

| | |
|--|----------|
| Reference | Page 148 |
| 7000 Series Nonstorage Mainframes | Page 155 |
| 7000 Series CRT Storage Mainframes | Page 168 |
| 7000 Series Digital Mainframes | Page 176 |
| 7000 Series Plug-ins | Page 183 |

The 7000 Series . . .

Superior Performance. The 7000 Series of plug-in laboratory instruments embodies more state-of-the-art performance features than any other oscilloscope-based measurement system. The 7104 Oscilloscope features a 1 GHz bandwidth combined with the fastest rise time and writing speed available today.

Flexibility. A choice of over 35 plug-ins and 19 mainframes gives you the flexibility to configure the scope package to meet your individual needs. When your needs change,

your present package can be reconfigured with a minimum of additional equipment and effort.

Expandability. This assures you that the instrument you buy today will adapt to changing measurement needs, and that it won't become obsolete soon after you buy it. Tektronix' most recent developments in plug-in scope capability are: the Waveform Processing Oscilloscope and the 1 GHz High Writing Rate Oscilloscope.

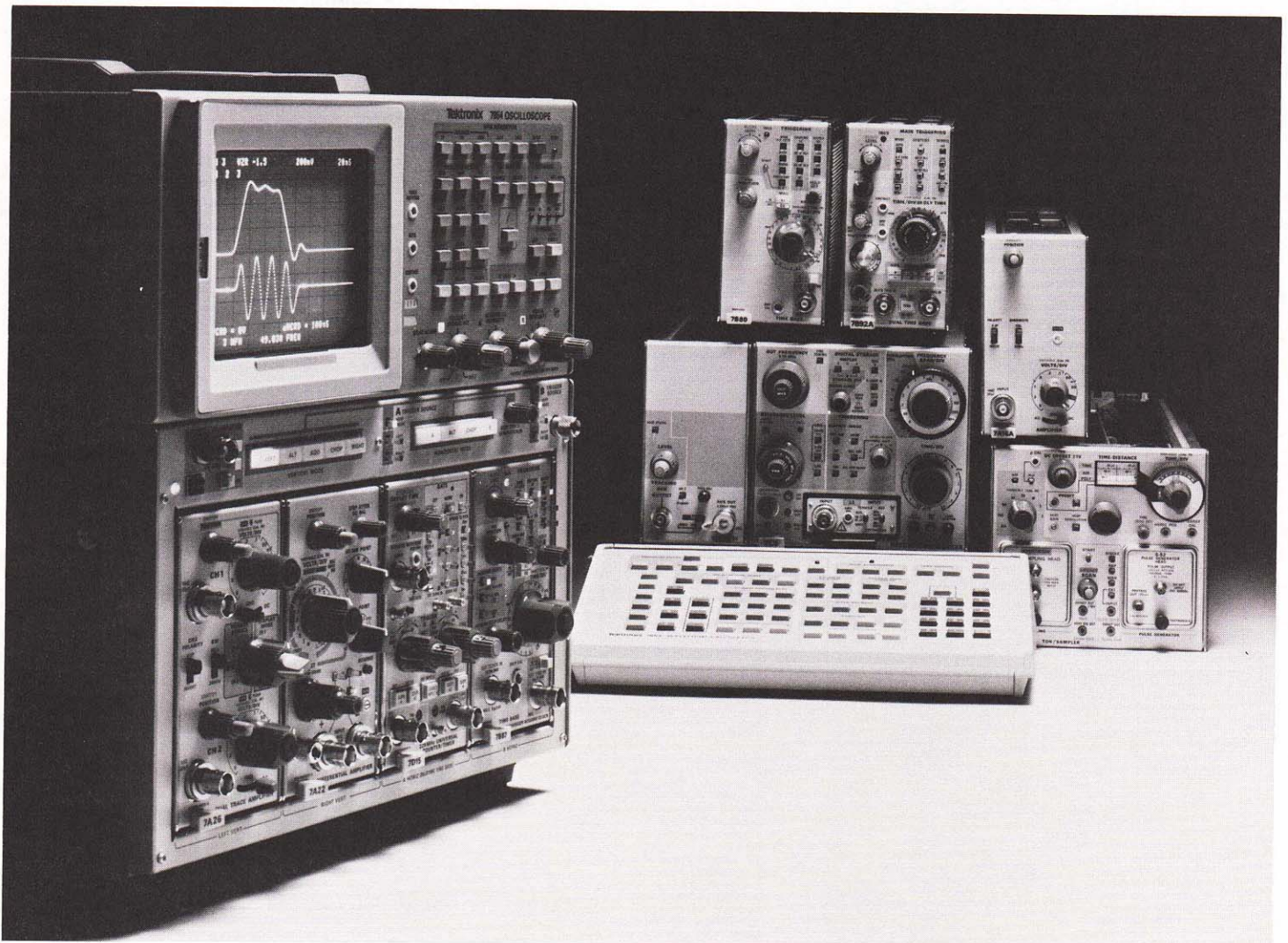

SUPERIOR PERFORMANCE, FLEXIBILITY AND EXPANDABILITY

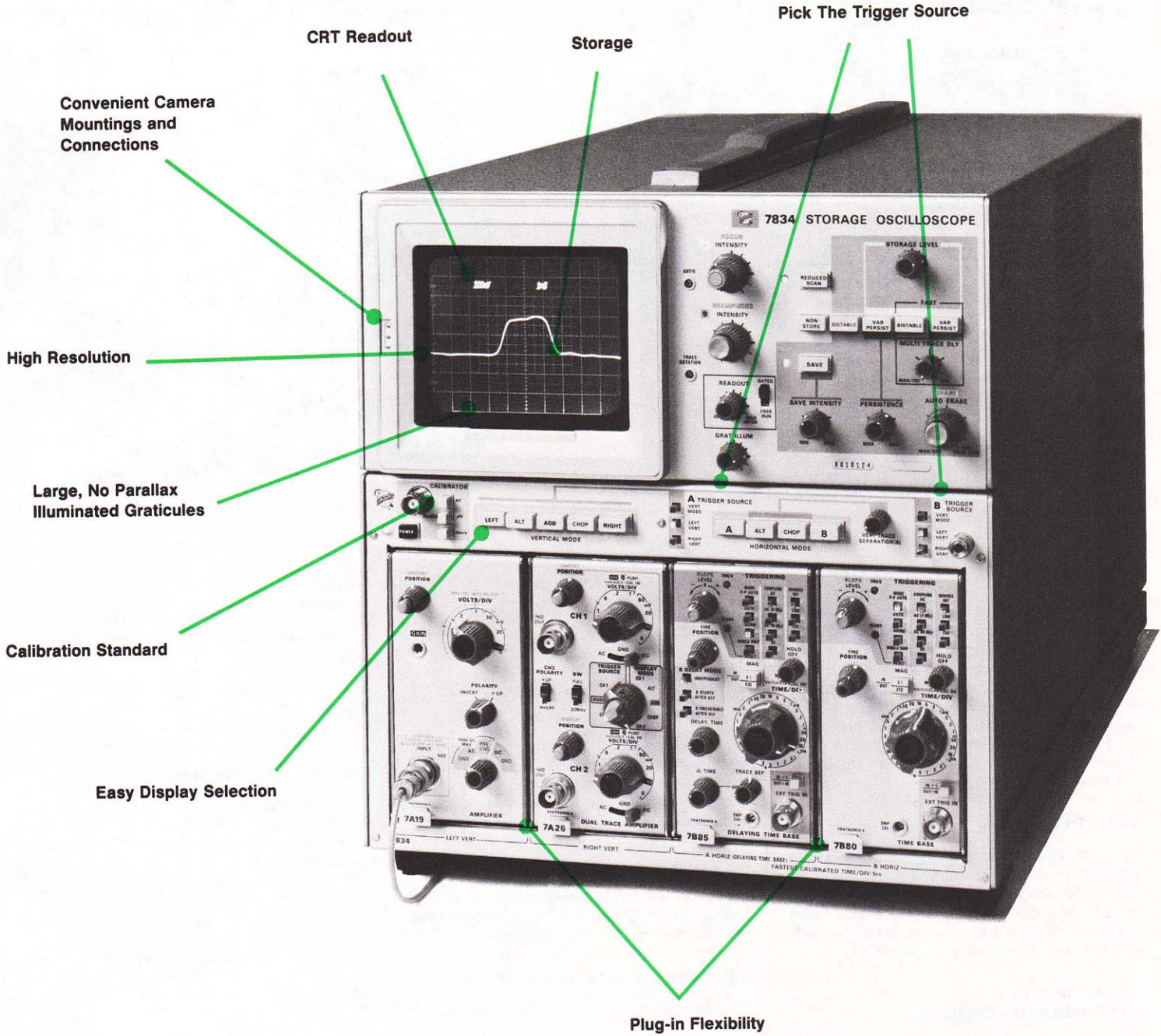

The 7000 Series is a unique family of instrumentation components, a continuation of the Tektronix commitment to bringing the ultimate in measurement technology to the laboratory.

Numerous measurement concepts—oscilloscopy, synergistic analog-digital measurements, spectrum analysis, sampling, time domain reflectometry, curve tracing—are fused into a family of interdependent cathode-ray-tube mainframes and instrumentation plug-ins.

A system can be tailored for your exact measurement needs. Mainframes in the family offer a choice of popular bandwidth ranges and a wide selection of additional features. Plug-ins—including oscilloscope vertical amplifiers and time bases as well as instruments for a variety of applications—can be selected to round out your tailored system.

In opposition to an industrial world that is frequently faulted for planning obsolescence, this instrument family strategically defers obsolescence. Each mainframe and each plug-in reflects the latest technology at its inception, yet each fits a well-planned niche in this interdependent family. The result is an array of instrumentation components that can adapt to our new developments while protecting your initial investment. Today's system may be expanded to meet future needs at a relatively low cost by the addition of a plug-in or two. When the time comes to add a more powerful mainframe, your older model continues to be useful for a host of applications.

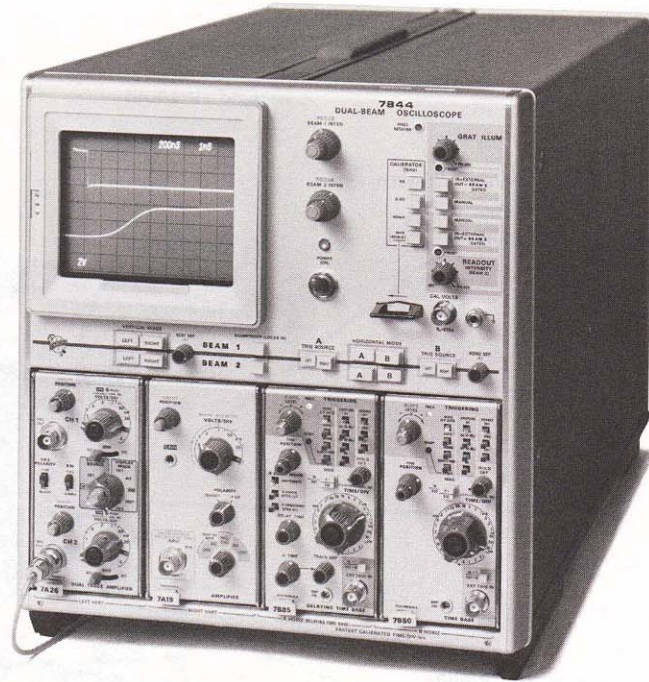

CRT Readout*

All significant parameters are displayed in alphanumeric characters right on the CRT. They are readily visible when you need them for quick oscilloscope measurements, and they are permanently recorded on your waveform photographs for future analysis. When your 7000 Series Measurement System includes a digital instrument plug-in, the measurement is presented in clear, accurate digital terms, along with a corresponding analog waveform.

Bright Traces

All 7000 Series CRTs have bright displays and excellent photographic writing speeds. For applications requiring maximum photographic writing speeds, several mainframes feature a reduced scan on a reduced area in the center of the CRT, and one uses a micro-channel plate CRT.

Large, Illuminated and Parallax-Free Graticules

The display area is 8 by 10 divisions (0.85, 0.9, 1.0, or 1.22 cm/div depending upon mainframe) with a parallax-free graticule.

Convenient Camera Mountings and Connections

A standard bezel connector matches all TEKTRONIX Oscilloscope Cameras to 7000 Series Mainframes.

Independent Intensity Controls

Separate intensity controls allow for independent adjustment of A sweep, B sweep, and character readout brightness. The intensity of each sweep may be adjusted to a level that suits your application.

Autofocus

The trace stays in focus with changes in intensity. After the focus is initially set, an autofocus circuit reduces the need for additional adjustments.

Adjustable Graticule Illumination

This gives you easier viewing and sharper photos.

Plug-ins Flexible Measurement Systems

More than 35 plug-ins provide you with flexibility to choose just the measurement capability you require.

Analog/Digital Synergism

Digital instrumentation plug-ins create unsurpassed measurement capabilities. Highly accurate digital measurements may be made at selectable points on complex waveforms by visually superimposing gate waveforms over signal waveforms.

Mainframes Calibration Standard

All the 7000 Series Calibrators serve as a voltage standard for calibrating vertical plug-ins, a 1 kHz squarewave for adjusting probe compensation, and a 1 kHz frequency standard in the 7800, 7900 and 7100 Series Mainframes. The output is available in several dc or 1 kHz squarewave voltages.

Trigger Source Flexibility

The left and right trigger selector mainframe pushbuttons route the desired trigger source to the appropriate time base. A VERT mode position automatically routes whichever source has been chosen for vertical inputs.

Easy Display Selection

Vertical mode switches allow you to easily select the desired vertical amplifier or interaction of amplifiers (e.g., alternate, chopped, or added modes). Four-compartment mainframes provide equivalent flexibility for time bases as well.

Mainframe Flexibility

Numerous options add even more flexibility in creating the oscilloscope system that most closely meets your measurement requirements.

*Not available in mainframes or plug-ins with "N" suffix.

7104 NON-STORAGE

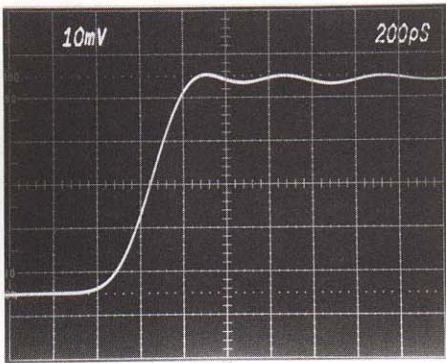

- 1 GHz Bandwidth
- 10 mV/div Sensitivity
- 200 ps/div Sweep Speed
- 20 cm/ns Writing Speed

DUAL BEAM

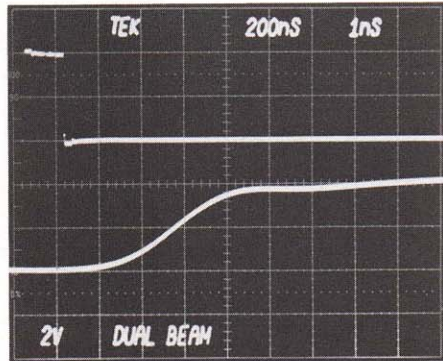

- 400 MHz Bandwidth
- Full Vertical and Horizontal Cross-over Switching (one input shown at two sweep speeds)
- Full Overlap on 8 x 10 cm Display

400 MHz Dual-Beam

Dual-beam oscilloscopes are essentially two oscilloscopes in one. Each beam operates separately and independently of the other. They are required for many applications where two transient events must be compared simultaneously. These application areas include stimulation and reaction events in such fields as medicine, biology, chemistry, engineering mechanics, to name just a few.

Depending on the plug-ins selected, up to eight traces can be displayed at a time.

SAMPLING/TIME DOMAIN REFLECTOMETRY

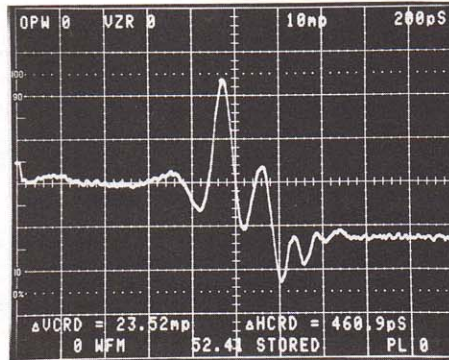

- Equivalent Bandwidth to 14 GHz
- Sweep Speeds to 10 ps/div
- High-Resolution 45 ps TDR: 7S12
- Self-Contained 1 GHz dual-trace sampler: 7S14
- Digital processing for sampling and TDR with 7854/7S12

DIGITAL READOUT MEASUREMENTS

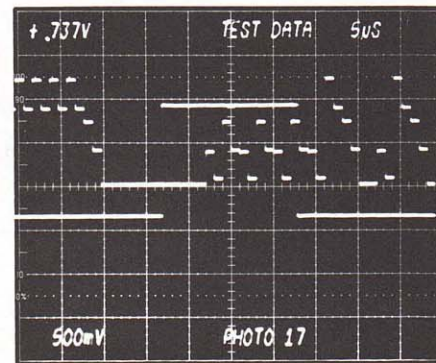

- Sample and Hold Dvm Measures Voltage Difference between Two Points on Complex Waveform (gate waveform indicates two points—leading and trailing edges—where voltage difference is made—+0.737 V)
- Readout Unit Identifies this Waveform as TEST DATA-PHOTO 17
- Counter/Timer Measurement with Analog Display
- Compare Digital Measurement with Analog Display

Digital Measurement Plug-ins

The 7000 Series Digital Plug-ins include: A universal counter/timer, digital multimeter with temperature mode, digital delay by time or events, a versatile 0.01% A/D converter with vertical amplifier, and a special read-out unit to label each test for future reference. Together with a 7000 Series Mainframe, these give you the advantage of seeing what you're measuring, plus accuracy of digital techniques.

This combination offers many advantages over separate test units. You get: scope-controlled digital measurements, measuring convenience and confidence, increased accuracy, easier and faster solutions to complex problems, a lower dollar investment, more bench space and signal conditioning.

Sampling

The 7000 Series Sampling Plug-ins provide some unique measurement capabilities not available in other sampling oscilloscopes. You get: A low-cost storage CRT for slow scans, a random mode that lets you see leading edges with pretrigger or bandwidth-limiting delay line, a wide choice of sampling heads at minimal cost, and the convenience of sampling and conventional displays at the same time on the CRT.

The adjacent sampling waveform shows the power of the 7S12 TDR plug-in with the 7854 Digital Storage Oscilloscope. First, the 7854 acquired the TDR signal from a prototype connector design, using waveform averaging to eliminate noise on the trace. Then, positioning the 7854 cursors to the area of interest on the waveform, the internal 7854 program calculates an impedance of 52.41 Ω at the discontinuity.

Spectrum Analysis

Unexcelled plug-in performance from 20 Hz to 60 GHz is provided by the 7L5, 7L14 and 7L18 Spectrum Analyzers. Stable, sensitive and spurious-free, these analyzers work in any 7000 Series Mainframe. The same mainframe may be used with other plug-ins for oscilloscope measurements.

Some plug-in analyzers have microprocessor-aided controls for easy operation, and digital storage and display capability for recalling and comparing signals. Others offer 30 Hz resolution for viewing close-together signals. Some optional tracking generators are available for swept frequency measurements.

Refer to the Spectrum Analyzer section beginning on p. 118 for more information.

CRT Storage
See page 169.

Digital Storage
See page 176

**7000 SERIES
OSCILLOSCOPE SYSTEMS/PROBE SELECTION CHART***

| PROBE | PASSIVE VOLTAGE 1 MΩ INPUT COMPATIBLE | | | | | | | PASSIVE VOLTAGE 50 Ω INPUT COMPT | | FET PROBES 50 Ω/1 MΩ INPUT COMPATIBLE | | | CURRENT PROBES | | |
|--------------------|--|---|---|---|---|--|---|----------------------------------|--|---|--|---|---|--|---|
| | P6101 1 Meter | P6108 1 Meter P6053B 3.5' | P6055 3.5' | P6009 9' | P6015 10' | P6062B 6' | P6105 P6108 2 Meter | P6056 6' | P6057 6' | P6202A*** 2 Meter | P6046 6' | P6201 6' | w/passive term P6021 5' 10 mV/mA | w/passive term P6022 5' 10 mV/mA | P6302/ AM 503 6' |
| FEATURES | Miniature Probe | Fastest Probes Compatible with 1-MΩ Input | Adj Attenuation for Differential Use | 1.5 kV Compatibility | 40 kV Pk Pulse Compatibility | Selectable Attenuation 1X:10X | Miniature Probe | Fastest 10X Passive Probe Low C | Fastest 100X Passive Probe Low C | 10-MΩ Input Impedance Dc, Offset | Differential Probe High Cmmr | Low Capacitive Loading Ac Coupling Dc Offset | Ac High Current | Ac High Frequency | Dc High Current |
| ATTENUATION | 1X | 10X | 10X | 100X | 1000X | Selectable | 10X | 100X | Selectable | Selectable | Selectable | Selectable | Selectable | Selectable | Selectable |
| 7104 | 7A19 7A24 7A26 7A29 | Nc Nc 34 MHz Nc | Nc Nc 175 MHz Nc | Nc Nc Nc | Nc Nc 125 MHz Nc | Nc Nc 75 MHz Nc | Nc Nc 100 MHz Nc | 500 MHz 350 MHz 950 MHz | 480 MHz 350 MHz 800 MHz | 300 MHz 300 MHz 185 MHz 450 MHz | 100 MHz 100 MHz 90 MHz 100 MHz | 430 MHz 310 MHz 195 MHz 660 MHz | Nc Nc 60 MHz Nc | Nc Nc 140 MHz Nc | 50 MHz 45 MHz 50 MHz 50 MHz |
| 7900 FAMILY | 7A11* 7A13 7A15A 7A16A 7A18 7A19 7A22 7A24 7A26 | Nc 34 MHz 34 MHz 34 MHz 34 MHz Nc 1 MHz Nc 34 MHz | Nc 105 MHz 75 MHz 200 MHz 75 MHz Nc Nc Nc 175 MHz | Nc 65 MHz Nc Nc 1 MHz Nc | Nc 85 MHz 70 MHz 130 MHz 70 MHz Nc Nc 125 MHz | Nc 65 MHz 80 MHz 80 MHz 60 MHz Nc Nc 75 MHz | Nc 75 MHz 75 MHz 75 MHz Nc | 500 MHz 350 MHz | 105 MHz 80 MHz 205 MHz 75 MHz 480 MHz 350 MHz | 105 MHz 80 MHz 205 MHz 75 MHz 300 MHz | 70 MHz 60 MHz 90 MHz 60 MHz 95 MHz | 105 MHz 75 MHz 215 MHz 75 MHz 430 MHz | 55 MHz 50 MHz 45 MHz 45 MHz 45 MHz Nc 1 MHz Nc 55 MHz | 150 MHz 90 MHz 70 MHz 150 MHz 70 MHz Nc 1 MHz Nc 140 MHz | 45 MHz 45 MHz 40 MHz 45 MHz 40 MHz 50 MHz 1 MHz 45 MHz 45 MHz |
| 7800 FAMILY | 7A11 7A13 7A15A 7A16A 7A18 7A19 7A22 7A24 7A26 | Nc 34 MHz 34 MHz 34 MHz 34 MHz Nc 1 MHz Nc 34 MHz | Nc 95 MHz 75 MHz 160 MHz 85 MHz Nc Nc Nc 145 MHz | Nc 65 MHz Nc Nc 1 MHz Nc | Nc 85 MHz 70 MHz 110 MHz 80 MHz Nc 1 MHz Nc 105 MHz | Nc 60 MHz 55 MHz 75 MHz 60 MHz 85 MHz Nc 1 MHz Nc 100 MHz | Nc 75 MHz 75 MHz 100 MHz 85 MHz Nc 1 MHz Nc 100 MHz | 400 MHz 300 MHz | 400 MHz 300 MHz | 100 MHz 80 MHz 170 MHz 75 MHz 320 MHz | 70 MHz 60 MHz 85 MHz 90 MHz 95 MHz | 100 MHz 80 MHz 165 MHz 90 MHz 360 MHz | 55 MHz 50 MHz 45 MHz 130 MHz 70 MHz Nc 1 MHz Nc 55 MHz | 130 MHz 85 MHz 70 MHz 130 MHz 40 MHz 50 MHz 1 MHz Nc 125 MHz | 45 MHz 45 MHz 40 MHz 45 MHz 40 MHz 50 MHz 1 MHz 45 MHz 45 MHz |
| 7704A | 7A11 7A13 7A15A 7A16A 7A18 7A19** 7A22 7A24 7A26 | Nc 34 MHz 34 MHz 34 MHz 34 MHz Nc 1 MHz Nc 34 MHz | Nc 100 MHz 70 MHz 145 MHz 75 MHz Nc Nc Nc 140 MHz | Nc 65 MHz Nc Nc 1 MHz Nc | Nc 85 MHz 65 MHz 115 MHz 70 MHz Nc Nc Nc 105 MHz | Nc 65 MHz 55 MHz 75 MHz 60 MHz Nc Nc Nc 75 MHz | Nc 70 MHz 100 MHz 75 MHz Nc 1 MHz Nc 100 MHz | 250 MHz 200 MHz | 250 MHz 200 MHz | 100 MHz 75 MHz 160 MHz 80 MHz 220 MHz 85 MHz | 70 MHz 60 MHz 150 MHz 70 MHz 215 MHz | 100 MHz 70 MHz 150 MHz 70 MHz 75 MHz 215 MHz | 55 MHz 50 MHz 45 MHz 70 MHz 45 MHz Nc Nc 1 MHz Nc 55 MHz | 125 MHz 85 MHz 70 MHz 125 MHz 70 MHz Nc 1 MHz Nc 115 MHz | 45 MHz 40 MHz 40 MHz 45 MHz 40 MHz 50 MHz 1 MHz 45 MHz 45 MHz |
| 7600 FAMILY | 7A11 7A13 7A15A 7A16A 7A18 7A22 7A26 | Nc 34 MHz 34 MHz 34 MHz 34 MHz Nc 1 MHz 34 MHz | Nc 75 MHz 60 MHz 95 MHz 70 MHz Nc Nc 95 MHz | Nc 55 MHz Nc 1 MHz Nc | Nc 60 MHz 55 MHz 85 MHz 65 MHz 85 MHz 65 MHz | Nc 70 MHz 60 MHz 95 MHz 95 MHz 70 MHz 1 MHz 95 MHz | Nc 70 MHz 60 MHz 95 MHz 95 MHz 70 MHz 1 MHz 95 MHz | | | 75 MHz 65 MHz 100 MHz 75 MHz | 55 MHz 50 MHz 70 MHz 55 MHz | 50 MHz 45 MHz 40 MHz 50 MHz 45 MHz 1 MHz 50 MHz | 85 MHz 70 MHz 60 MHz 85 MHz 70 MHz 1 MHz 85 MHz | 40 MHz 40 MHz 35 MHz 40 MHz 40 MHz 1 MHz 40 MHz | |

*Note: The values in the above table represent the approximate useful frequency response for the measurement systems at the probe tip.

If there is no bandpass specified the probe/plug-in combination is compatible but not recommended.

** = Option 09 Mainframe

Nc = Not compatible

*** = Requires 1101 Power Supply when used with 7834, 7854, 7603, 7633, 7623 or 7613.

RECOMMENDED COMBINATIONS 7000 SERIES MAINFRAMES AND TIME BASES

| MAINFRAME | | 7104 | 7904 R7903 | 7844/R 7854 7834 | 7704A R7704 | 7603/R | 7603N11 | 7633/R 7623A/R | 7613/R | |
|---------------------|---|-------------------------------------|---------------|------------------------|----------------|--------|---------|-------------------|--------|--|
| Time Base | PERFORMANCE FEATURE | ● INDICATES RECOMMENDED COMBINATION | | | | | | | | |
| 7B50A | Single time base | | | | | ● | ●(2) | ● | ● | |
| 7B53A | Dual time base with mixed sweep | | | | | ● | ●(2) | ● | ● | |
| 7B53A Opt 05 | 7B53A with tv sync triggering | | | | | ● | ●(2) | ● | ● | |
| 7B80 | Single time base (used also as delayed time base) | | ● | ● | ● | | | | | |
| 7B85 | Single time base with delaying and Δ delay sweep function | | ● | ● | ●(1) | | | | | |
| 7B92A | Dual time base with display switching | | ● | ● | ●(1) | | | | | |
| 7B10 | Single time base (used also as delayed time base) | ● | ● | ● | ● | | | | | |
| 7B15 | Single time base with delaying and Δ delay sweep function | ● | ● | ● | ●(1) | | | | | |

¹No trace separation on R7704 only.

²No mainframe readout.

7000 SERIES VERTICAL SYSTEM SPECIFICATIONS

| PLUG-IN AMPLIFIER | | 7A11 | 7A13 | 7A15A | 7A16A | 7A17 | 7A18 | 7A19 | 7A22 | 7A24 | 7A26 | 7A29 | |
|---|--|-------------------------------------|--|--|---|---------------------------------------|------------------------|-------------------------------------|--|-----------------------------|------------------------|---------------------------------|----------|
| PAGE | | 187 | 186 | 184 | 184 | 186 | 185 | 188 | 187 | 188 | 185 | 188 | |
| PERFORMANCE FEATURE | | Low-capacitance FET probe amplifier | Differential dc offset, high-freq cmrr amplifier | Low cost conventional input amplifier | Wide bandwidth conventional input amplifier | Low cost, easy to customize amplifier | Dual-channel amplifier | Wide bandwidth 50 Ω input amplifier | Dc-coupled, high-gain differential amplifier | Dual-channel 50 Ω amplifier | Dual-channel amplifier | Widest Bandwidth Single Channel | |
| MIN DEFL FACTOR | | 5 mV/div | 1 mV/div | 5 mV/div (0.5 mV/div) ² | 5 mV/div | 50 mV/div | 5 mV/div | 10 mV/div | 10 μV/div | 5 mV/div | 5 mV/div | 10 mV/div | |
| ACCURACY¹ WITHOUT PROBE | | 2% (Integral) | 1.5% | 2% | 2% | — | 2% | 3% | 2% | 2% | 2% | 2% | |
| 7100 FAMILY (0°C to 35°C) | 7104 | BW | 250 MHz | 100 MHz P6053B* 100 MHz P6106** 65 MHz P6055 | 80 MHz | 225 MHz | 150 MHz | 75 MHz | 600 MHz | 1 MHz ± 10% | 400 MHz | 200 MHz | 1000 MHz |
| | | Tr | 1.4 ns | 3.5 ns P6053* 3.5 ns P6106** 5.4 ns P6055 | 4.4 ns | 1.6 ns | 2.4 ns | 4.7 ns | 0.6 ns | 300 ns ± 9% | 0.9 ns | 1.8 ns | 0.38 ns |
| 7900 FAMILY (0°C to 30°C) | 7904 R7903 7912AD ^{3,4} | BW | 250 MHz | 105 MHz P6053B* 105 MHz P6106** 65 MHz P6055 | 80 MHz | 225 MHz | 150 MHz | 75 MHz | 500 MHz | 1 MHz ± 10% | 350 MHz | 200 MHz | 500 MHz |
| | | Tr | 1.4 ns | 3.4 ns P6053B* 3.4 ns P6106** 5.4 ns P6055 | 4.4 ns | 1.6 ns | 2.4 ns | 4.7 ns | 0.8 ns | 350 ns ± 9% | 1.0 ns | 1.8 ns | 0.8 ns |
| | | SIG OUT BW | 140 MHz | 100 MHz P6053B* 100 MHz P6106** 65 MHz P6055 | 70 MHz | 140 MHz | 15 MHz | 70 MHz | 300 MHz | 1 MHz ± 10% | 140 MHz | 140 MHz | 300 MHz |
| 7800 FAMILY (0°C to 35°C) | 7844/R | BW | 200 MHz | 100 MHz P6053B* 100 MHz P6106** 65 MHz P6055 | 80 MHz | 200 MHz | 150 MHz | 75 MHz | 400 MHz ⁴ | 1 MHz ± 10% | 300 MHz | 180 MHz | 400 MHz |
| | | Tr | 1.8 ns | 3.5 ns P6053B* 3.5 ns P6106** 5.4 ns P6055 | 4.4 ns | 1.8 ns | 2.4 ns | 4.7 ns | 0.9 ns | 350 ns ± 9% | 1.2 ns | 1.9 ns | 0.9 ns |
| | 7854 ⁷ 7834 | BW | 200 MHz | 95 MHz P6053B* 95 MHz P6106** 65 MHz P6055 | 80 MHz | 200 MHz | 150 MHz | 75 MHz | 400 MHz ⁴ | 1 MHz ± 10% | 300 MHz | 180 MHz | 400 MHz |
| | | Tr | 1.8 ns | 3.7 ns P6053B* 3.7 ns P6106** 5.4 ns P6055 | 4.4 ns | 1.8 ns | 2.4 ns | 4.7 ns | 0.9 ns | 350 ns ± 9% | 1.2 ns | 1.9 ns | 0.9 ns |
| 7700 FAMILY (0°C to 50°C) | 7704A Opt 9 (0°C to 30°C) | BW | 170 MHz | 100 MHz P6053B* 100 MHz P6106** 65 MHz P6055 | 75 MHz | 170 MHz | 150 MHz | 75 MHz | 250 MHz ⁵ | 1 MHz ± 10% | 200 MHz | 170 MHz | 250 MHz |
| | | Tr | 2.1 ns | 3.5 ns P6053B* 3.5 ns P6106** 5.4 ns P6055 | 4.7 ns | 2.1 ns | 2.4 ns | 4.7 ns | 1.5 ns | 350 ns ± 9% | 1.8 ns | 2.1 ns | 1.5 ns |
| | 7704A (0°C to 50°C) | SIG OUT BW | 70 MHz | 60 MHz P6053B* 60 MHz P6106** 50 MHz P6055 | 55 MHz | 70 MHz | 15 MHz | 55 MHz | 80 MHz | 1 MHz ± 10% | 70 MHz | 70 MHz | 80 MHz |
| | | BW | 170 MHz | 100 MHz P6053B* 100 MHz P6106** 65 MHz P6055 | 75 MHz | 160 MHz | 150 MHz | 75 MHz | 200 MHz | 1 MHz ± 10% | 200 MHz | 150 MHz | 200 MHz |
| | R7704 (0°C to 50°C) | Tr | 2.1 ns | 3.5 ns P6053B* 3.5 ns P6106** 5.4 ns P6055 | 4.7 ns | 2.2 ns | 2.4 ns | 4.7 ns | 1.8 ns | 350 ns ± 9% | 1.8 ns | 2.4 ns | 1.8 ns |
| | | SIG OUT BW | 70 MHz | 60 MHz P6053B* 60 MHz P6106** 50 MHz P6055 | 55 MHz | 70 MHz | 15 MHz | 55 MHz | 80 MHz | 1 MHz ± 10% | 70 MHz | 70 MHz | 80 MHz |
| 7600 FAMILY and STORAGE FAMILY (0°C to 50°C) | 7603/R 7633/R (0°C to 50°C) | BW | 100 MHz | 75 MHz P6016 55 MHz P6055 | 65 MHz | 100 MHz | 100 MHz | 75 MHz | 100 MHz | 1 MHz ± 10% | 100 MHz | 100 MHz | 100 MHz |
| | | Tr | 3.5 ns | 5.0 ns P6016 6.4 ns P6055 | 5.4 ns | 3.5 ns | 3.5 ns | 4.7 ns | 3.5 ns | 350 ns ± 9% | 3.5 ns | 3.5 ns | 3.5 ns |
| | 7603N11 ⁵ (0°C to 50°C) | SIG OUT BW | 60 MHz | 55 MHz P6016 45 MHz P6055 | 50 MHz | 60 MHz | 15 MHz | 50 MHz | 65 MHz | 1 MHz ± 10% | 60 MHz | 60 MHz | 65 MHz |
| | | BW | 80 MHz | 65 MHz | 60 MHz | 80 MHz | 80 MHz | 65 MHz | 80 MHz | 1 MHz ± 10% | 80 MHz | 80 MHz | 80 MHz |
| | 7612D ⁸ (0°C to 40°C) | Tr (Calculated) | 5.0 ns | 6.0 ns | 6.7 ns | 5.0 ns | 5.0 ns | 6.0 ns | 5.0 ns | 350 ns ± 9% | 5.0 ns | 5.0 ns | 5.0 ns |

System Environmental Specifications. Operating altitude to 15,000 feet. Non-operating to 50,000 feet.

¹Accuracy percentages apply to all deflection factors. Plug-in gain must be set at the deflection factor designated on each plug-in. When a probe is used, the gain must be set with the calibration signal applied to the probe tip. The calibration signal is supplied by an external calibrator whose accuracy is within 0.25%.

²Obtained with 10X gain at reduced bandwidth of 10 MHz.
³Refer to Transient Digitizer, 7912AD not available with signal outputs.

⁴Bandwidth is 325 MHz to 10 mV/div.

⁵Bandwidth is 200 MHz at 10 mV/div.

⁶All 7000 Series Plug-ins are compatible with the 7603N Opt 11. However, they do not meet the rigid environmental specifications required by the military.

⁷Bandwidth with equivalent time sampling and time display only.

⁸Fully programmable mainframe. 7A16P Programmable Amplifier recommended. 7A16P provides 200 MHz, 1.8 ns in 7912AD and 80 MHz, 5.0 ns in 7612D, see page 113.

*P6053B has Trace Identify
**P6106 has Ground Reference

DIMENSIONS AND WEIGHTS 7000 SERIES MAINFRAMES AND PLUG-INS

| Dimensions | 7612D | | 7912AD | *7854 | 7104 | 7904 | R7903 | 7844 | R7844 | 7834 | 7704A | R7704 | 7603 | R7603 | 7603NMS | 7633, 7623A, 7613 | R7633, R7623A, R7613 | PLUG-INS SINGLE DOUBLE | |
|------------------|-------|-------|--------|-------|------|------|-------|------|-------|------|-------|-------|------|-------|---------|-------------------------|----------------------------|---------------------------|------|
| | cm | in | cm | cm | cm | cm | cm | cm | cm | cm | cm | cm | cm | cm | cm | cm | cm | cm | cm |
| Height | 17.8 | 7 | 17.8 | 34.8 | 34.5 | 34.3 | 13.5 | 32.8 | 17.8 | 34.5 | 34.5 | 17.8 | 29.0 | 13.3 | 29.2 | 30.5 | 13.3 | 12.7 | 12.7 |
| | 7 | 7 | 7 | 13.7 | 13.6 | 13.5 | 5.3 | 12.9 | 7.0 | 13.6 | 13.6 | 7.0 | 11.4 | 5.25 | 11.5 | 12.0 | 5.25 | 5.0 | 5.0 |
| Width | 48.3 | 19 | 48.3 | 30.5 | 30.5 | 30.5 | 48.3 | 30.5 | 48.3 | 30.5 | 30.5 | 48.3 | 8.7 | 19.0 | 9.7 | 8.7 | 19.0 | 2.8 | 5.5 |
| | 19 | 19 | 19 | 12 | 12.0 | 12.0 | 19.0 | 12.0 | 19.0 | 12.0 | 12.0 | 19.0 | 8.7 | 19.0 | 9.7 | 8.7 | 19.0 | 2.8 | 5.5 |
| Length | 67.9 | 26.75 | 67.9 | 62.7 | 59.2 | 59.2 | 57.9 | 60.5 | 63.0 | 58.9 | 57.7 | 56.9 | 61.0 | 62.7 | 64.0 | 59.7 | 56.6 | 36.8 | 36.8 |
| | 26.75 | 26.75 | 26.75 | 24.7 | 23.5 | 23.3 | 22.8 | 23.8 | 24.8 | 23.2 | 22.7 | 22.4 | 24.0 | 24.7 | 25.2 | 23.5 | 22.3 | 14.5 | 14.5 |
| Weights (approx) | kg | 25 | 22.7 | 20.4 | 19.8 | 14.5 | 12.3 | 16.3 | 15.0 | 16.1 | 13.6 | 20.0 | 13.6 | 20.4 | 13.6 | 13.6 | 14.5 | 0.9 | 4.1 |
| | lb | 55 | 50 | 45 | 43.6 | 32 | 27 | 36 | 33 | 35.5 | 30 | 44 | 30 | 45 | 30 | 30 | 32 | 2 | 9 |
| Shipping | kg | | 32.6 | 28.1 | 25.4 | 20 | 23.6 | 21.3 | 28.5 | 21.3 | 19.5 | 35.0 | 20.8 | 28.2 | 32.7 | 19.0 | 28.2 | 2.3 | 5.4 |
| | lb | | 72 | 62 | 56 | 44 | 52 | 47 | 63 | 47 | 43 | 77 | 46 | 62 | 72 | 42 | 62 | 5 | 12 |

*7854 Calculator dimensions and weights, Height 2.7 in. (6.9 cm), Width 10.9 in. (27.7 cm), Length 6.5 in. (16.5 cm).



TEK Lab Cart Model 3

Model 3 Lab Cart accepts all 7000 Series Oscilloscopes. A lockable drawer for storage and a movable shelf for additional instrumentation are included. The shelf accepts TM 500 Test and Measurement Instruments, 5000 Series Oscilloscopes, or 400 Series Oscilloscopes.

For full details see SCOPE-MOBILE® Cart section, page 344.

SUMMARIZED CAMERA CHARACTERISTICS

| RECOM- MENDED CAMERA | OSCILLO- SCOPIES | PERFORMANCE FEATURES AND BENEFITS | LENS | | | | FILM BACKS | | PRICE with Pack back |
|----------------------------|-------------------------------------|---|---------------------------------|------------------------------------|--------------------|--|-------------------------|--------------------------------------|-------------------------------|
| | | | MAXIMUM RELATIVE APERTURE | MAG | RELATIVE SPEED* | FIELD OF VIEW (with 3.25 x 4.25 in Polaroid Film except where noted) | ORDI- NARILY USED | OPTIONAL AND INTER- CHANGEABLE | |
| C-51P | 7904, R7903, 7844, 7704A 7854 | Fastest writing speed with 0.5 mag lens. | f/1.2 | 0.5 | 3.0 | 8 x 10 cm/ 3.15 x 3.93 in | Polaroid Pack | 4 x 5 in Graflok | \$ 1935 |
| C-53P | All except 7603 7603N11S | General-purpose with 0.85 mag lens. | f/1.9 | 0.85 | 1.0 | 8 x 10 cm/ 3.15 x 3.93 in | Polaroid Pack | 4 x 5 in Graflok | \$ 1590 |
| C-59AP | 7603 7603N11S | General-purpose at low price. | f/2.8 | 0.67 | 0.65 | 10.2 x 12.7 cm/ 4 x 5 in | Polaroid Pack | 4 x 5 in Graflok | \$ 1165 |
| C-5C | All | Low cost. | f/16 | 0.67 or 0.85 select- able | 0.02 | 9.76 x 12.2 cm | Polaroid Pack | None | \$ 500 |

*Relative light-gathering power.

C-50 Series Camera Adapter, part number 016-0249-03, included with camera.
For full details see Camera section, page 321.

Following is a list of currently available Application Notes for 7000 Series.

| Title | Featuring | Part No. | Title | Featuring | Part No. |
|---|--|-----------|---|---|-----------|
| ULTRASONIC MEASURE- MENTS with digital accuracy | 7603/7A22/7D15/7B53A Timing measurements between non-adjacent pulses. Ultrasonic transducers | AX-3681 | DIGITAL INSTRUMENTS Combined within Tektronix Oscilloscope give unparalleled accuracy and capability | 7000 Series digital plug-ins (counter-timers, DVM's, tem- perature probes, sample-hold modules) with application examples. | A-3002 |
| EASIER, FASTER, MORE ACCURATE Oscilloscope timing measurement | 7B85/7B80 Delayed sweep & delta time measurements | A-3269 | MEASUREMENT VARIETY An Engineering challenge featuring the 7854 | 7854/WAVEFORM CALCULATOR demonstrating basic opera- tion, application software for percent overshoot, data monitoring and histogram. | AX-4281 |
| X-Y DISPLAYS with interval timing for measuring SOA | 7D15/7A18/7A22 X-Y power dissipation measurements | AX-3957 | GPIB COMMUNICATION with the 7854 | 7854/4052 and 7854/4924 types of I/O transfers, trans- mission formats, and opera- tional software in TEK Basic compatible with any 4050 Series computer | AX-4416 |
| DAC MEASUREMENTS: The sampling oscilloscope approach | 7S14/7D12/M2/7B92A/7904 Measuring DAC (digital analog converter) settling time | AX-3632 | Pulse and digital timing meas- urements—a better technique | 7B80/7B85 General overview of the opera- tion of the 7B85 and 7B80 Delta-Time Measurement Plug-ins | AX-3379-1 |
| SCR GATING WAVEFORM MEASUREMENTS with high- resolution digital accuracy | 7D12/M2/7A16A (four compart- ment main frames) SCR measurements. Absolute and relative (two point) voltage monitoring | A-2693 | Using storage to find trouble- some logic glitches | 7633 Shows how the 7633 Storage Oscilloscope can be used to capture and evaluate glitches | AX-3085 |
| Digital delay in an oscilloscope makes your radar pulse time delay measurements quicker, easier, and more accurate | 7D11 The measurement of radar pulse delay time is given as an example of 7D11 operation | AX-2659-2 | Variable persistence storage applications | 7613/5441 Describes various applications for variable persistence storage oscilloscopes | AX-3198 |
| Measuring time interval between non-adjacent digital word train pulses or multi-echo radar pulses | 7D15 Demonstrates the ability of the 7D15 to measure the time between adjacent pulses with digital counter accuracy | AX-2680-2 | Bistable storage applications | Tektronix Storage Oscillo- scopes. Describes various applications for bistable storage oscilloscopes | AX-3199 |
| Measuring memory core I/O signals with digital accuracy | 7000 Series Digital Plug-ins Demonstrates how digital plug-ins can be used to make accurate pulse parameter measurements both of ampli- tude and pulse timing | AX-2686-1 | Introduction to 7854 Oscillo- scope Measurement to Pro- gramming Techniques | 7854 Programming Techniques | AX-4682 |
| Measuring disc drive time and access voltages with Tektronix 7000 Series Digital Plug-ins | 7000 Series Digital Plug-ins Use a single CRT display to perform both digital and analog analysis of complex waveforms | AX-2687-1 | | | |

7000 SERIES NON-STORAGE MAINFRAMES

CONTENTS

| | |
|--|-----|
| 7104 1 GHz General Purpose | 156 |
| 7904/R7903 500 MHz General Purpose | 158 |
| 7844/R7844 400 MHz Dual Beam | 160 |
| 7704A/R7704 200 MHz General Purpose | 162 |
| 7603/R7603 100 MHz General Purpose | 164 |
| 7603N11S Ruggedized Oscilloscope System | 166 |

A high performance instrument system begins with the basic oscilloscope building block — the 7000 Series Mainframe. Each mainframe consists of a cathode-ray tube, a power supply, electron beam deflection systems, and the switching circuitry necessary to integrate a versatile and complete measurement system.

The TEKTRONIX 7104 is a 1 GHz oscilloscope featuring the fastest rise time (350 ps) and writing speed (20 cm/ns) available today.

Choose from a variety of features, including bandwidth, dual-beam, alphanumeric displays, rackmounting, and three- or four-plug-in flexibility.

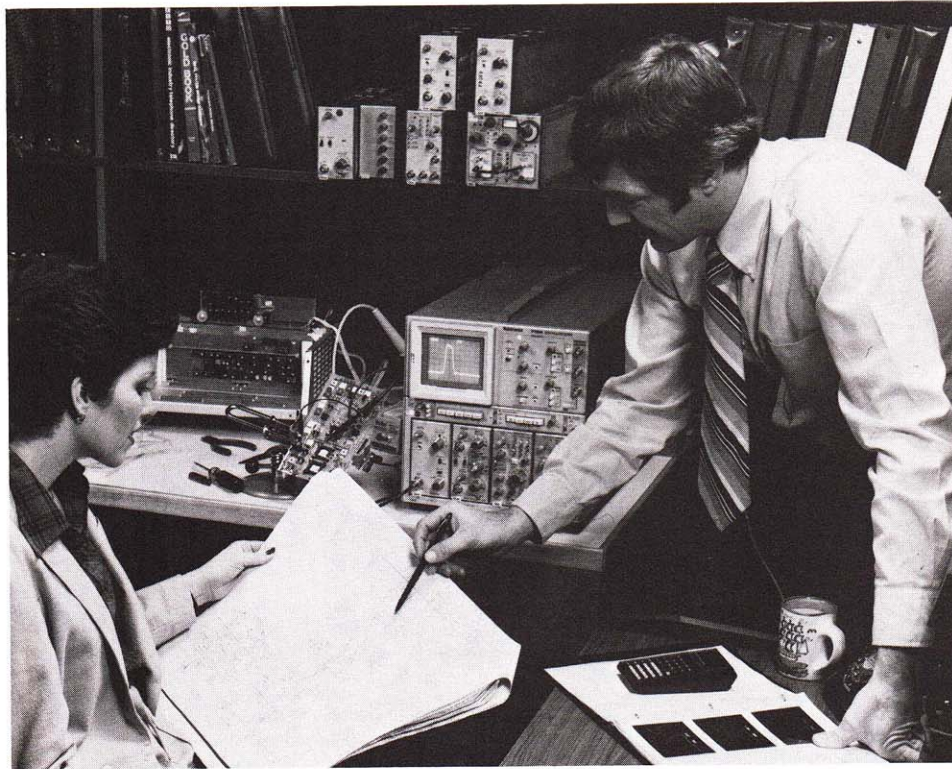

7104

Ultra High Writing Speed

1 GHz at 10 mV/div

0.38 ns Risetime

200 psec/div Fastest Calibrated Sweep Rate

Horizontal Bandwidth 350 MHz

Phase Compensation Option—Phase Matching to 250 MHz

CRT Readout

APPLICATIONS

High Speed Semiconductor Design

Laser and High Energy Research

Digital Communications

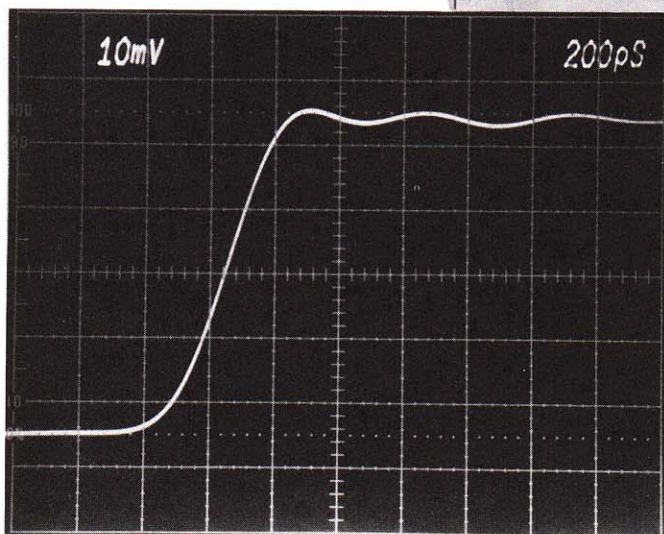
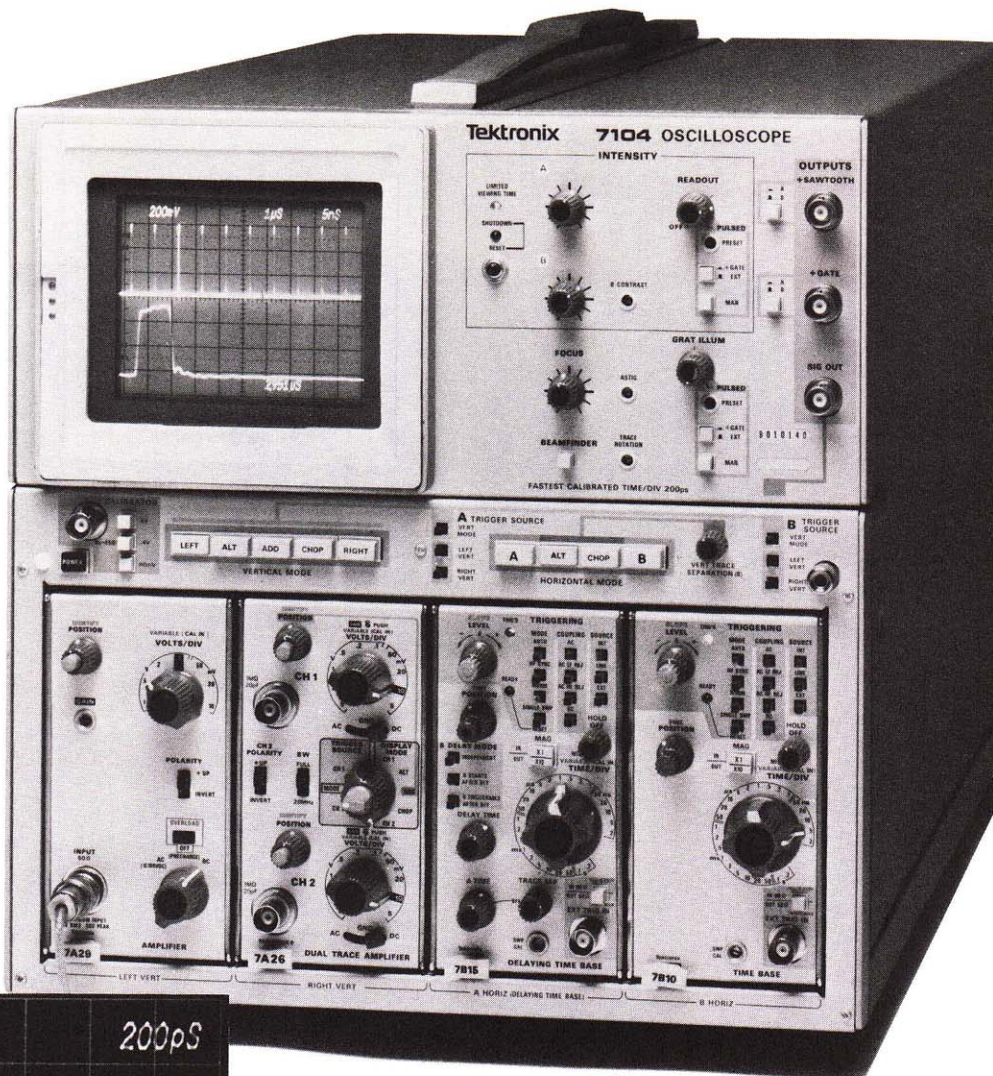

The 7104 has both the highest writing speed and highest bandwidth available in a general-purpose oscilloscope today.

The 7104 with 7A29 Amplifier plug-ins provides 1 GHz realtime vertical bandwidth at 10 mV/div. Combined with the 7B10/7B15 Time Base plug-ins, having fastest sweep speeds of 200 ps/div, very high-speed signals can now be measured with confidence.

The 7104's outstanding writing speed means unsurpassed single-shot capability, with trace brightness about **one-thousand times** that of conventional oscilloscopes. Any single-shot signal within the 7104's bandwidth can be seen directly on the CRT in average room light. Also, single-shot photography is now simple and straightforward, using standard oscillographic cameras and film without high-speed enhancement techniques.

Horizontal bandwidth of 350 MHz, with the X-Y phase compensation Option 02, gives accurate X-Y displays to 250 MHz. Designers can now directly obtain V-I curves for high-speed switching power supply evaluation or monitor performance of digital communication systems using phase constellation displays.

VERTICAL SYSTEM

Channels — Two left-hand plug-in compartments; compatible with all 7000 Series Plug-ins. Bandwidth determined by mainframe and plug-in unit.

Vertical Display Modes — LEFT, ALT, ADD, CHOP, RIGHT.

Chopped Mode — Repetition rate is ≈ 1 MHz.

Vertical Trace Separation — Operative when any vertical signal is displayed with both A and B time bases. Positions B trace at least 4 div above and below A trace.

Delay Line — Permits viewing leading edge of displayed waveform.

HORIZONTAL SYSTEM

Channels — Two right-hand plug-in compartments; compatible with the time bases of the 7B10 and 7B80 Series and the 7B50A and 7B92A. The 7B50 Series (except the 7B50A), the 7B70 Series and the 7B92 (non A) are not recommended. 7000 Series Vertical Amplifiers and specialized plug-ins may also be used.

Horizontal Display Modes — A, ALT, CHOP, B.

Fastest Calibrated Sweep Rate — 200 ps/div with the 7B10 or 7B15.

Chopped Mode — Repetition rate is ≈ 200 kHz.

Bandwidth — Dc to 350 MHz. With delay compensation (7104 Option 02 using 7A19s or 7A29s, at least one of which has the Variable Delay Option, B Horizontal compartment only), within 2° from dc to 50 MHz after adjusting variable delay for balance at 35 MHz. Phase balance can be obtained at any frequency up to 250 MHz. Phase shift is within 2° from dc to 50 kHz without delay compensation.

Horizontal Bandwidth: 350 MHz

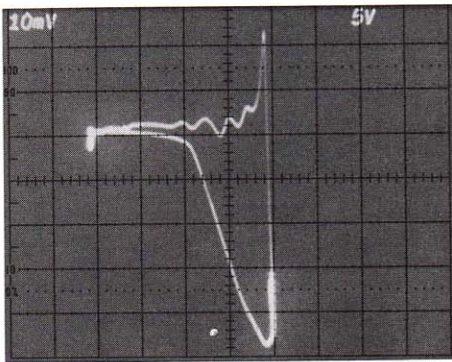

The transient load line of a fast switching transistor in a power supply prototype (switching time = 10 ns) is easily measured for compliance with safe operating area. (Horizontal = V; vertical = I).

CRT AND DISPLAY FEATURES

CRT — Internal 8 x 10 div (0.85 cm/div) graticule with variable illumination. Accelerating potential is 12.5 kV with P31 Phosphor standard.

Readout and Graticule Modes — Each continuous or pulsed (pulse source selector by front panel controls: + Gate, external, manual). The pulsed graticule is on for ≈ 0.5 s.

Min Photographic writing speed (using Polaroid film type 106, 20,000 ASA w/out film fogging) — 20 cm/ns (w/o blue filter). Phosphor: standard P31. Camera: TEKTRONIX C-53, f/1.9, 1:0.85 lens.

Autofocus — Reduces the need for additional manual focusing with changes in intensity after focus control has been set.

Beam Finder — Limits display within graticule area.

External Z-Axis Input — 2 V p-p for full intensity range. A positive signal blanks the trace. Max input voltage is 15 V (dc + peak ac) and p-p ac. Input is dc coupled.

1 GHz at 10 mV/div

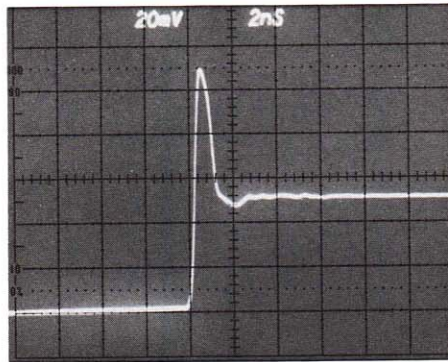

Circuit faults such as high frequency pulse overshoot and ringing can easily be observed with the 7104's 1 GHz bandwidth.

Writing Speed: 20 cm/ns

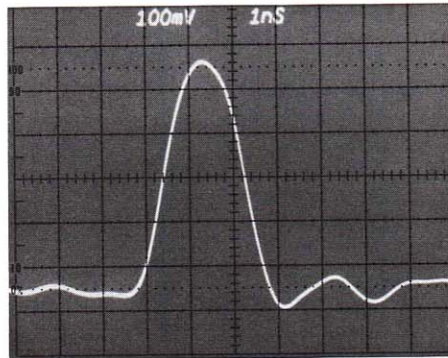

View of a single clocking pulse 0.8 ns rise and 2 ns pulse width.

CALIBRATOR

Voltage Output — Squarewave positive-going from ground. Ranges are 40 mV, 0.4 V, and 4 V into 100 k Ω ; 4 mV, 40 mV, and 0.4 V into 50 Ω . Amplitude accuracy is within 1%; repetition rate is 1 kHz within 0.25%.

Current Output — 40 mA rectangular waveshape with optional current-loop accessory (012-0341-00) connected to calibrator output. Output R is 450 Ω .

Plug-in Compatibility



Plug-in compatibility. The 7104 is compatible with standard 7000 Series plug-in units that provide for full 7104 system performance.

The 7D01 and 7D02 Logic Analyzers are not recommended for use with the 7104 Mainframe. Such use will void the 7104 warranty.

Distinct Image Viewing

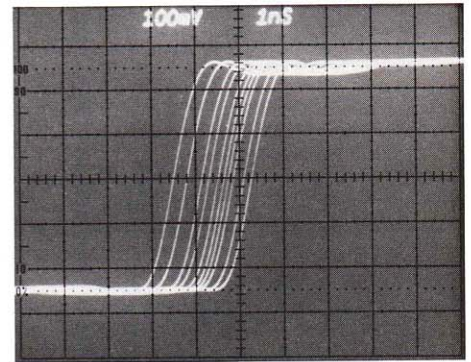

A digital circuit that shows no jitter on a conventional oscilloscope is found to have a 2.0 ns jitter when viewed with the distinct image viewing capability of the 7104.

OUTPUTS/INPUTS

+ Sawtooth — User selectable from A or B horizontal. Output voltage is 50 mV/div ($\pm 5\%$) into 50 Ω , 1 V/div ($\pm 10\%$) into 1 M Ω . Output R is ≈ 950 Ω .

+ Gate — Positive-going rectangular waveform user selectable from A or B horizontal. Output voltage is 0.5 V ($\pm 10\%$) into 50 Ω , 10 V ($\pm 10\%$) into 1 M Ω . Output R is ≈ 950 Ω .

Sig Out — Selected by B TRIGGER SOURCE switch. Output voltage is 25 mV/div into 50 Ω , 0.5 V into 1 M Ω . Bandwidth depends upon vertical plug-in. Output R is ≈ 950 Ω .

Camera Power — Three-prong connector to the left of the CRT provides power, ground, and remote single-sweep reset access for C-50 Series Camera.

Probe Power — Two rear-panel connectors provide correct operating voltages for two active probes.

Single-sweep Ready Indicators A and B — +5 V, rear panel BNC outputs for single sweep ready indications.

Graticule/Readout, Single-shot — Ground closure, rear panel BNC input initiates one frame of CRT read-out and the GRAT ILLUM is illuminated for ≈ 0.5 s.

External Single-sweep Reset — Ground closure, rear panel BNC, provides input to reset sweep.

POWER REQUIREMENTS

Power Requirements — Line voltage ranges, 90 to 132 V ac and 180 to 250 V ac. Line frequency, 48 to 440 Hz. Max power consumption, 215 W, 3.3 A at 90 V line, 60 Hz.

Dimensions and Weights — See page 153.

For Recommended Cameras — See page 154

For Recommended Plug-ins — See page 152.

7104 ORDERING INFORMATION (Plug-ins not included)

7104 Oscilloscope \$18,945

OPTIONS

Option 02 X-Y Horiz Comp Add \$300
Option 03 Emc Modification Add \$300

INTERNATIONAL POWER CORDS AND PLUG OPTIONS

Option A1 Universal Euro 220 V/16A No Charge
Option A2 UK 240 V/13A No Charge
Option A3 Australian 240 V/10A No Charge
Option A4 North American 240 V/15A No Charge

7A29 — Vertical amplifier to bw of mainframe; 10 mV/div to 1 V/div vertical sensitivity.

7B10 — Delayed timebase (similar to 7B80) with 200 ps/div to 0.2 s/div calibrated sweep speed; triggering up to 1 GHz.

7B15 — Delaying timebase (similar to 7B85) with 200 ps/div to 0.2 s/div calibrated sweep speed; triggering up to 1 GHz; capable of Δ time measurements in conjunction with 7B10.

7904 R7903

500 MHz at 10 mV/div

0.8 ns Risetime

500 ps/div Fastest
Calibrated Sweep Rate

Greater Than 15 cm/ns Enhanced
Writing Speed

CRT Readout

Over 30 Compatible Plug-ins

900 MHz FET Probe Available

APPLICATIONS

Digital Design

Radar

Laser Research

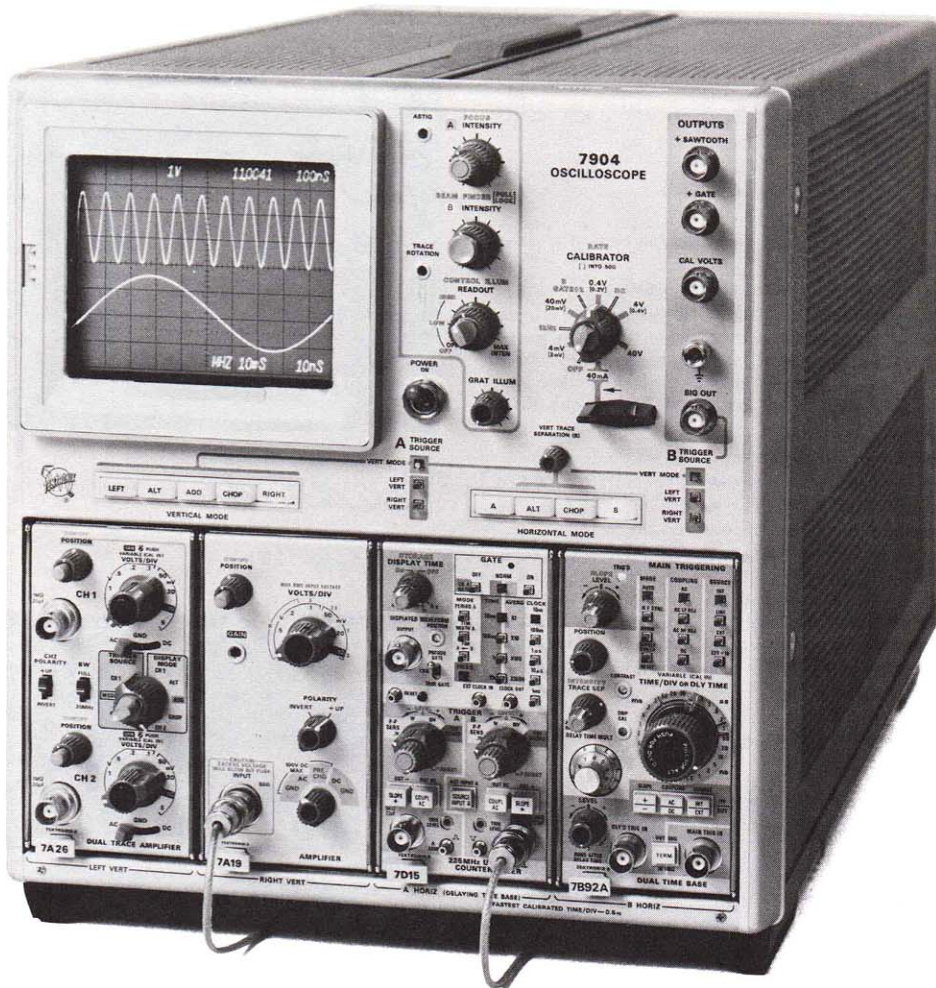

The 7904 and 5.25 in rackmount R7903 are high bandwidth, general-purpose oscilloscopes. The 7A19 Amplifier/7904 Mainframe attains 500 MHz at 10 mV/div. A 7A19 variable delay option allows for the matching of signal transit times of two plug-ins and their probes to better than 50 ps.

The P6201 1X FET probe gives you high impedance and wide bandwidth. It has a 900 MHz bandwidth by itself, and in combination with the 7A19/7904, it provides a system bandwidth of 450 MHz at 10 mV.

The CRT, the major contributor to the performance of the 7904 and R7903, has good visual brightness and an 8 x 10 cm display area.

7904 and R7903 — VERTICAL SYSTEM

Channels — Two left-hand plug-in compartments; compatible with all 7000 Series Plug-ins. Bandwidth determined by mainframe and plug-in unit.

Modes of Operation — LEFT, ALT, ADD, CHOP, RIGHT.

Chopped Mode — Repetition rate is ≈ 1 MHz.

Trace Separation Range (Dual-sweep Modes) — The B trace can be positioned 4 divisions above or below the A trace (7904 only).

Delay Line — Permits viewing leading edge of displayed waveform when using 7B80 and 7B90 Series Time Bases. 7B50 Series not recommended.

7904 — HORIZONTAL SYSTEM

Channels — Two right-hand plug-in compartments; compatible with time bases of the 7B80 and 7B90 Series. 7000 Series Vertical Amplifiers and specialized plug-ins may also be used.

Fastest Calibrated Sweep Rate — 500 ps/div with the 7B92A.

Chopped Mode — Repetition rate is ≈ 200 kHz.

X-Y Mode — Phase shift is within 2° from dc to 35 kHz without phase correction (dc to 1 MHz with phase correction, Option 02) between vertical and horizontal channels. Bandwidth is dc to at least 1 MHz.

R7903 — HORIZONTAL SYSTEM

Single Channel — Right-hand plug-in compartment compatible with time bases of 7B80 and 7B90 Series. 7000 Series Vertical Amplifiers and specialized plug-ins may also be used.

Fastest Calibrated Sweep Rate — 500 ps/div with the 7B92A.

7904 and R7903

CRT AND DISPLAY FEATURES

Standard — Internal 8 x 10 cm graticule with variable illumination. Accelerating potential is 24 kV with P31 Phosphor standard.

Option 01, Without CRT Readout — No CRT readout.

Option 04, Max Brightness CRT With Reduced Area — Internal 4 x 5 cm graticule with variable illumination. Accelerating potential is 24 kV. P11 Phosphor provides max writing rate. This provides extremely high photographic and information writing speed and increases the visibility of low-rep-rate, high-speed signals.

Option 78, P11 Phosphor

Option 10, Pulsed Graticule (R7903 Only) — Provides a means of pulsing the graticule lights at a preset level coincident with a single-shot event in one exposure. The graticule lights may be pulsed by the event, an external ground closure, or a front panel pushbutton. If the mainframe is equipped with CRT readout, Option 10 provides additional controls and inputs for CRT readout pulsed operation.



The R7903 requires only 5.25 in of rack height in a standard 19 in rack. It is fan-cooled and comes complete with slide-out chassis tracks.

Typical Photographic Writing Speed Using The Optional P11 Phosphor and Polaroid Type 612 20,000 ASA Film without Film Fogging

| CRT | Camera | Lens | Writing Speed cm/ns |
|--------------------|--------|-------|---------------------|
| Standard 8 x 10 cm | C-51P | f/1.2 | 2.5 |
| Option 04 4 x 5 cm | | 1:0.5 | 4 |

In typical applications, P31 Phosphor has approximately one-half the writing speed of P11 Phosphor. The writing speed can be increased by using controlled film fogging with a writing speed enhancer (camera accessory).

Autofocus — Reduces the need for additional manual focusing with changes in intensity after focus control has been set.

Beam Finder — Limits display within graticule area.

External Z-Axis Input — 2 V p-p for full intensity range. A positive signal blanks the trace. Max input voltage is 15 V (dc + peak ac) and p-p ac. Input is dc coupled.

7904 — CALIBRATOR

Output Waveshape — Rectangular positive-going from ground, 1 kHz ($\pm 0.25\%$), dc or B Gate $\div 2$.

Voltage Ranges — 4 mV, 40 mV, 0.4 V, 4 V, 40 V into an open circuit; 2 mV, 20 mV, 0.2 V, 0.4 V into 50 Ω ($\pm 1\%$).

Current Output — 40 mA dc or 1 kHz.

R7903 — CALIBRATOR

(Not Available with Option 10)

Output Waveshape — Rectangular positive-going from ground, 1 kHz ($\pm 0.25\%$).

Voltage Ranges — 4 mV, 40 mV, 0.4 V, 4 V into an open circuit; 4 mV, 40 mV, 0.4 V into 50 Ω ($\pm 1\%$).

Current Output — 40 mA rectangular waveshape with optional current-loop accessory (012-0341-00) connected to calibrator output. Output R is 450 Ω .

7904 — OUTPUTS/INPUTS

+Sawtooth — Sawtooth starts 1 V or less from ground (into 1 M Ω). Internally selectable from A or B horizontal. Output voltage is 50 mV/div ($\pm 5\%$) into 50 Ω , 1 V/div ($\pm 10\%$) into 1 M Ω . Output R is $\approx 950 \Omega$.

+GATE — Positive-going rectangular waveform derived from A, B, or Delayed Gate, internally selectable. Output voltage is 0.5 V ($\pm 10\%$) into 50 Ω , 10 V ($\pm 10\%$) into 1 M Ω . Rise time is 5 ns or less into 50 Ω . Output R is $\approx 950 \Omega$.

Sig Out — Selected by B TRIGGER SOURCE switch. Output voltage is 25 mV/div into 50 Ω , 0.5 V/div into 1 M Ω . Bandwidth depends upon vertical plug-in. See the Vertical System Specifications Chart. Output R is $\approx 950 \Omega$.

Camera Power — Three-prong connector to the left of the CRT provides power, ground, and remote single-sweep reset access for C-50 Series Cameras.

Probe Power — Two rear-panel connectors provide correct operating voltages for two active probes.

R7903 — OUTPUTS/INPUTS

(Standard)

+Sawtooth — Sawtooth starts 1 V or less from ground (into 1 M Ω). Output voltage is 50 mV/div ($\pm 15\%$) into 50 Ω , 1 V/div ($\pm 10\%$) into 1 M Ω . Output R is $\approx 950 \Omega$.

+Gate — Positive-going rectangular waveform derived from Main or Auxiliary Gate. Output voltage 0.5V ($\pm 10\%$) into 50 Ω , 10 V ($\pm 10\%$) into 1 M Ω . Rise time is 7 ns or less into 50 Ω . Output R is $\approx 950 \Omega$.

Sig Out — Selected by TRIGGER SOURCE switches. Output voltage is 25 mV/div into 50 Ω , 0.5 V/div into 1 M Ω . Bandwidth depends on the vertical plug-in. See the Vertical System Specifications Chart. Output R is $\approx 950 \Omega$.

Single-sweep Ready Indicator — +5 V, rear panel BNC output, for single-sweep ready indication.

External Single-sweep Reset — Ground closure, rear panel BNC, provides input to reset sweep.

CRT Readout, Inhibit — Ground closure, rear panel BNC input locks out CRT readout. Not available with Option 10.

CRT Readout, Single-shot — Ground closure, rear panel BNC input initiates one frame of CRT readout. Not available with Option 10 separately, but in combination with the pulsed graticule input.

Camera Power — Three-prong connector to the left of the CRT provides power, ground, and remote single-sweep reset access for C-50 Series Cameras.

Probe Power — Two front-panel connectors provide correct operating voltages for two active probes. Not available for R7903 Option 10.

R7903 — OUTPUTS/INPUTS OPTIONS

Option 10, Pulsed Graticule — No CRT readout single-shot input. CRT readout inhibit input, calibrator, and probe power. Single-shot graticule and CRT readout (ground closure) rear-panel BNC input is added. Initiates one frame of CRT readout and pulses graticule. CRT readout inputs are not functional with Option 01.

POWER REQUIREMENTS

7904 Power Requirements — Line voltage ranges, 90 to 132 V ac and 180 to 264 V ac. Line frequency, 48 to 440 Hz. Max power consumption, 190 W, 2.5 A at 115 V line, 60 Hz.

R7903 Power Requirements — Line voltage ranges, 90 to 132 V ac and 180 to 264 V ac. Line frequency, 48 to 440 Hz. Max power consumption, 160 W, 2 A at 115 V line, 60 Hz.

7904 Included Accessories — Test adapter (012-0092-00); two 18 in test leads (012-0087-00); 9 pin cable-mount plug (134-0049-00).

R7903 Included Accessories — Test adapter (012-0092-00); two 18 in test leads (012-0087-00); rack-mounting hardware.

Dimensions and Weights — See page 153.

For Recommended Cameras — See page 154.

For Recommended Plug-ins — See page 152.

7904 ORDERING INFORMATION

(Plug-ins not Included)

7904 Oscilloscope \$8000

7904 OPTIONS

- Option 01 without CRT Readout Sub \$300
- Option 02 X-Y Horiz Comp Add \$250
- Option 03 Emc Modification Add \$300
- Option 04 Max Brightness CRT with 4x5 cm Display (Specify Phosphor) Add \$500
- Option 78 P11 Phosphor Add \$35

7904 CONVERSION KITS

- 040-0605-03 CRT Readout \$1000
- 040-0606-00 X-Y Horiz Comp \$260
- 040-0570-00 Emc Modification \$420

INTERNATIONAL POWER CORD AND PLUG OPTIONS

- Option A1 Universal Euro 220 V/16A No Charge
- Option A2 UK 240 V/13A No Charge
- Option A3 Australian 240 V/10A No Charge
- Option A4 North American 240 V/15A No Charge

R7903 ORDERING INFORMATION

(Plug-ins not Included)

R7903 Oscilloscope \$7545

R7903 OPTIONS

- Option 01 without CRT Readout Sub \$300
- Option 03 Emc Modification Add \$300
- Option 04 Max Brightness CRT with 4x5 cm Display (Specify Phosphor) Add \$500
- Option 10 Pulsed Graticule Add \$150
- Option 78 P11 Phosphor Add \$35

R7903 CONVERSION KITS

- 040-0605-03 CRT Readout \$1000
- 040-0647-00 Emc Modification \$280

INTERNATIONAL POWER CORD AND PLUG OPTIONS

- Option A1 Universal Euro 220 V/16A No Charge
- Option A2 UK 240 V/13A No Charge
- Option A3 Australian 240 V/10A No Charge
- Option A4 North American 240 V/15A No Charge

7844 R7844

400 MHz Bandwidth

0.9 ns Risetime

Dual Beam

Full Vertical Crossover Switching

8 x 10 cm Display

CRT Readout

1 ns/div Max Calibrated Sweep

APPLICATIONS

Radar/Lidar

Destructive Testing

SCR Switching

The 7844 and 7 inch rackmount R7844 are wide bandwidth, dual-beam oscilloscopes designed primarily for fast, single-shot events. Unique features such as pulsed graticule and pulsed crt readout allow you to photograph vertical and horizontal scale factors, test date, test number, and other pertinent data before or after an event. Vertical signal crossover switching permits you to view a single event from a single probe at two sweep speeds.

VERTICAL SYSTEM

Channels — Two left-hand plug-in compartments; compatible with all 7000 Series Plug-ins. Bandwidth determined by main-frame and plug-in unit.

Display Logic —

| | Beam 1 | Beam 2 |
|----------------------|--------|--------|
| Vertical Compartment | Left | Left |
| Controlling Beam | Left | Right |
| | Right | Left |
| | Right | Right |

Vertical Crossover — Permits viewing the same signal on two time bases.

Vertical Trace Separation — Beam 1 can be positioned ± 4 cm with respect to Beam 2.

Delay Line — Permits viewing leading edge of displayed waveform when using 7B80 and 7B90 Series Time Bases; not compatible with 7B50 Series.

HORIZONTAL SYSTEM

Channels — Two right-hand plug-in compartments; compatible with time bases of the 7B80 and 7B90 Series. 7000 Series Vertical Amplifiers and specialized plug-ins may also be used. 7B53AN11 requires modification for use in the 7844.

Fastest Calibrated Sweep Rate — 1 ns/div.

X-Y Mode — Phase shift is within 2° from dc to 50 kHz.

Bandwidth — Dc to at least 1 MHz.

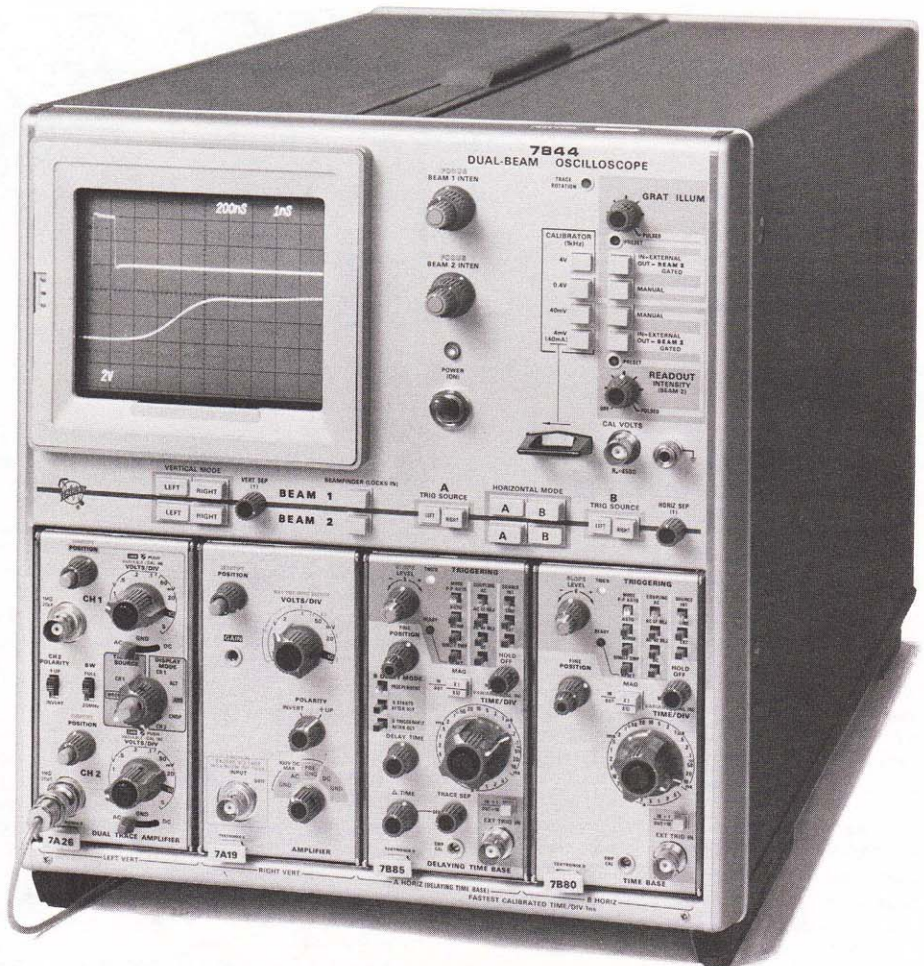

Horizontal Separation — Beam 1 can be positioned at least 0.25 cm to the right and at least 0.25 cm to the left of Beam 2 with a total 2 cm range.

Display Logic —

| Beam 1 | Beam 2 |
|--------------|--------------|
| A Horizontal | A Horizontal |
| A Horizontal | B Horizontal |
| B Horizontal | A Horizontal |
| B Horizontal | B Horizontal |

CRT AND DISPLAY FEATURES

CRT — Dual beam, full overlap. 8 x 10 cm graticule with variable illumination. CRT readout intensity is adjustable with front-panel control. Accelerating potential is 24 kV with P31 phosphor standard.

Option 78, P11 Phosphor.

Autofocus — Reduces the need for additional manual focusing with changes in intensity after focus control has been set.

Beam Finder (Beam 1 and Beam 2, Independent Controls) — Limits display within graticule area and intensifies beam.

External Z-Axis Input (Beam 1 and Beam 2) — 2 V p-p for full intensity range. A positive signal blanks the trace. Max input voltage is 15 V (dc + peak ac) and p-p ac. Input is dc coupled.

Typical Photographic Writing Speed (Using Polaroid Type 612 20,000 ASA Film without Film Fogging)

In typical camera applications, P31 Phosphor has about one-half the writing speed of P11 Phosphor. Writing speed can be increased by using controlled film fogging with a writing speed enhancer.

The photographic writing speed enhancer, Option 22, provides a preset automatic method of film fogging for the 7844. Option 22 is recommended for writing speed enhancement when a camera with a writing speed enhancer is not available.



PULSED READOUT AND GRATICULE ILLUMINATION

Provides a means of pulsing the graticule lights or CRT readout at a preset level, coincident with a single-shot event in one exposure. The graticule lights or CRT readout can be pulsed by the event, an external ground closure, or front-panel pushbutton.

CALIBRATOR

Calibrator — Rectangular positive-going waveform from ground, 1 kHz ($\pm 0.25\%$).

Voltage Ranges — 4 mV, 40 mV, 0.4 V, 4 V ($\pm 1\%$) into an open circuit; 0.4 mV, 4 mV, 40 mV, 0.4 V ($\pm 1\%$) into 50 Ω .

Current Output — 40 mA ($\pm 1\%$) rectangular waveshape, front panel current loop 7844, optional current loop adapter (012-0341-00) required for R7844.

OUTPUTS/INPUTS

A and B + Sawtooth — Sawtooth starts 1 V or less from ground (into 1 M Ω). Output voltage is 50 mV/div ($\pm 15\%$) into 50 Ω , 1 V/div ($\pm 10\%$) into 1 M Ω . Output R is $\approx 950 \Omega$.

A and B + Gate — Positive-going rectangular waveform derived from Main or Delayed Gate. Output voltage 0.5 V ($\pm 10\%$) into 50 Ω , 10 V ($\pm 10\%$) into 1 M Ω . Rise time is 5 ns or less into 50 Ω . Output R is $\approx 950 \Omega$.

Single-sweep Ready Indicator — +5 V, rear panel BNC output, for single-sweep ready indication.

External Single-sweep Reset — Ground closure, rear panel BNC, provides input to reset sweeps.

Camera Power — Three-prong connector to the left of the CRT provides power, ground, and remote single-sweep reset access for C-50 Series Cameras.

Probe Power — Two connectors provide correct operating voltages for two active probes.

POWER REQUIREMENTS

Line Voltage Ranges — Selectable 115 V nominal (90-132 V), 230 V nominal (180-264 V).

Line Frequency — 48 to 440 Hz.

Max Power Consumption — 235 W, 2.9 A at 60 Hz 115 V line.

INCLUDED ACCESSORIES

R7844 — 1 rackmount hardware kit, 1 rackmount slide guide (351-0314-01).

Dimensions and Weights — See page 153.

For Recommended Cameras — See page 154.

For Recommended Plug-ins — See pages 152.

ORDERING INFORMATION

(Plug-ins not included)

| | |
|--------------------------|----------|
| 7844 Oscilloscope | \$11,900 |
| R7844 Oscilloscope | \$12,320 |

OPTIONS

| | |
|---|-----------|
| Option 03 Emc Modification | Add \$300 |
| Option 22 Writing Speed Enhancer Modification | Add \$400 |
| Option 78 P11 Phosphor | Add \$35 |

INTERNATIONAL POWER CORD AND PLUG OPTIONS

| | |
|--|-----------|
| Option A1 Universal Euro 220 V/16A | No Charge |
| Option A2 UK 240 V/13A | No Charge |
| Option A3 Australian 240 V/10A | No Charge |
| Option A4 North American 240 V/15A | No Charge |

STEP RISE TIME (ns)

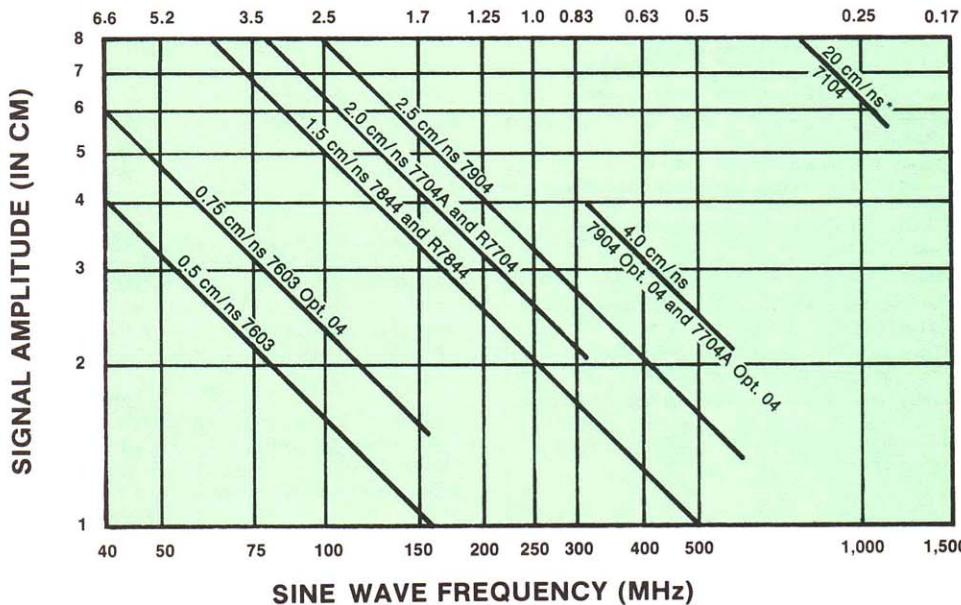

Amplitude vs. speed and photographic writing speed comparison of 7000 Series Mainframes using optional P11 Phosphors, 20,000 ASA film and the C-51 (f/1.2, 1:0.5) Camera.

*20 cm/ns is the specified photographic writing speed for the 7104 Mainframe. However, it is not correctly comparable to the other mainframes here because of relaxed phosphor, film and

camera requirements. The microchannel plate CRT as well as the bright photographed image allow for these relaxed requirements. Standard P31 Phosphor is used and a C-53 (f/1.9, 1:0.85 image) Camera.

PHOTOGRAPHIC WRITING RATE

This graph shows the relative photographic writing speed of the 7000 Series Mainframes and the amplitude-speed relationship for each.

Vertical signal amplitude on the vertical scale is shown against maximum sinewave frequency (lower scale) and fastest rise time (upper scale). These speeds assume a small horizontal spot velocity compared to the maximum vertical velocity. The step ramp is assumed to be a linear ramp measured between 10% and 90% points.

To obtain these minimum photographic writing speeds, open the camera shutter before the sweep and leave open for 5 seconds after the sweep. Develop the film for 30 seconds at 25°C. View with front illumination. The limit of photographic writing speed will be a barely discernible trace in the center of the photographic image.

The standard P31 Phosphor has a spectral output that gives about one-half the photographic writing speed of the above optional P11 Phosphor. The visual output of the P31 Phosphor is, however, about six times greater than that of the optional P11.

7704A R7704

Dc to 200 MHz with Optimum Pulse Response

1.8 ns Risetime

Dc to 250 MHz Bandwidth Option

Greater than 15 cm/ns Enhanced Writing Speed with Optional CRT and WSEN

CRT Readout

APPLICATIONS

Communications

Digital Design

Component Testing

The 7704 family is a wide bandwidth general-purpose oscilloscope measurement system.

The 7704A Oscilloscope offers you the capability to optimize the oscilloscope's response for your type of work. For pulse analysis aberrations are reduced below the normal level in the optimized transient response version while still giving you a bandwidth of 200 MHz. The 250 MHz option is optimized for bandwidth performance for high-frequency applications. The R7704 offers a 175 MHz bandwidth.

Quite often the need arises to photograph the waveforms that are produced. The 7704A gives you a choice of two designs available for this purpose: the standard 8 x 10 cm CRT and an optional 4 x 5 cm reduced-scan CRT for high writing-speed applications. For additional information on the Writing Speed Enhancer (WSEN) see pages 316 and 320; for a comparison of the 7000 Series writing rate specifications see page 161.

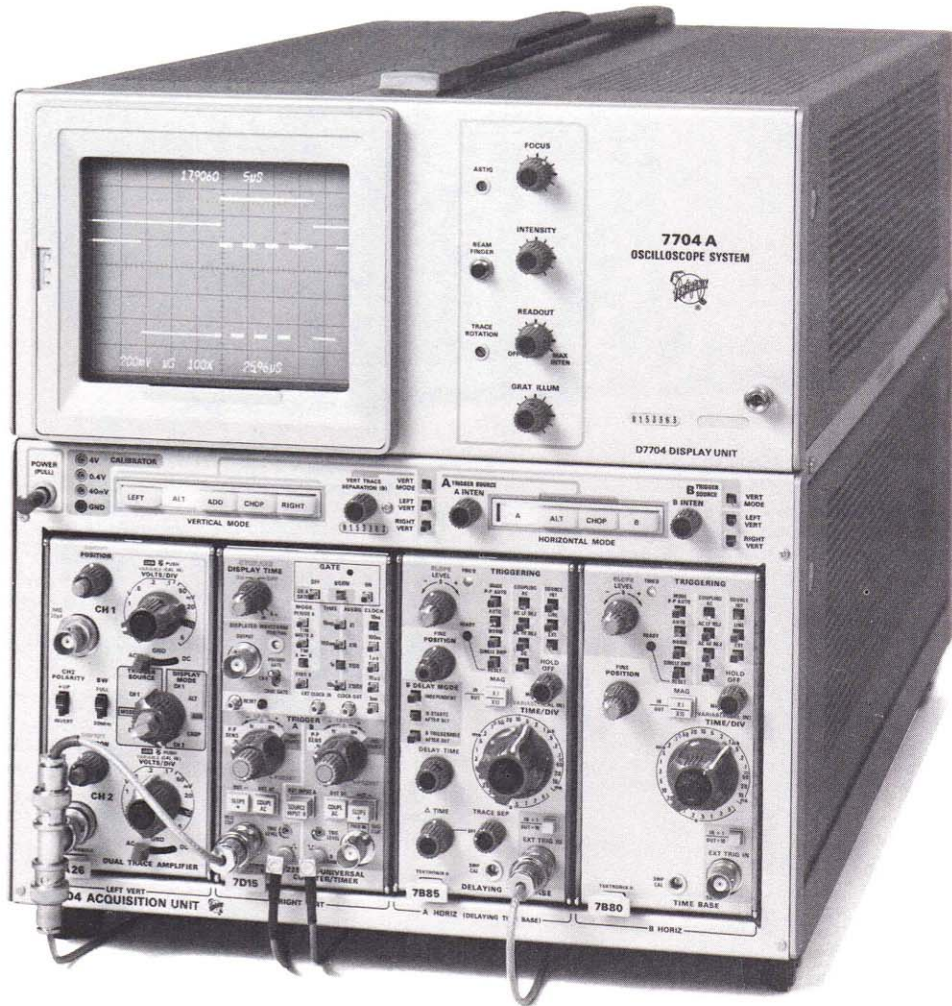

VERTICAL SYSTEM

Channels — Two left-hand plug-in compartments; compatible with all 7000 Series Plug-ins. Bandwidth determined by main-frame and plug-in unit; see Vertical System Specifications Chart.

Option 09 Bandwidth Change (250 MHz) — 7704A vertical circuit performance is adjusted to extend frequency response to 250 MHz at 20 mV/div (upper -3 dB) when 7A19 is used. Provides additional performance for those working in this frequency domain.

Modes of Operation — LEFT, ALT, ADD, CHOP, RIGHT.

Chopped Mode — 7704A, repetition rate is internally selectable, ≈100 kHz or 1 MHz; R7704, fixed at ≈1 MHz.

Trace Separation Range (Dual-sweep Modes) — The B trace can be positioned above or below the A trace.

Delay Line — Permits viewing leading edge of waveform.

HORIZONTAL SYSTEM

Channels — Two right-hand plug-in compartments; compatible with all 7000 Series Plug-ins.

Fastest Calibrated Sweep Rate — 2 ns/div with 7B80 or 7B90 Series.

Chopped Mode (between Horizontal Plug-ins) — 7704A, repetition rate is internally selectable, ≈20 kHz or 200 kHz; R7704, fixed at ≈200 kHz.

X-Y Mode — Phase shift is within 2° from dc to 50 kHz (7704A), from dc to 35 kHz (R7704) between vertical and horizontal channels. Frequency response at 10% down is dc to at least 3 MHz.

Option 02, X-Y Horizontal Compensation (R7704 only) — Provides phase shift compensation to <2° from dc to 2 MHz.

CRT

Standard — Internal 8 x 10 cm graticule with variable illumination. Accelerating potential is 24 kV with P31 Phosphor standard.

Option 01, Without CRT Readout — No CRT readout.

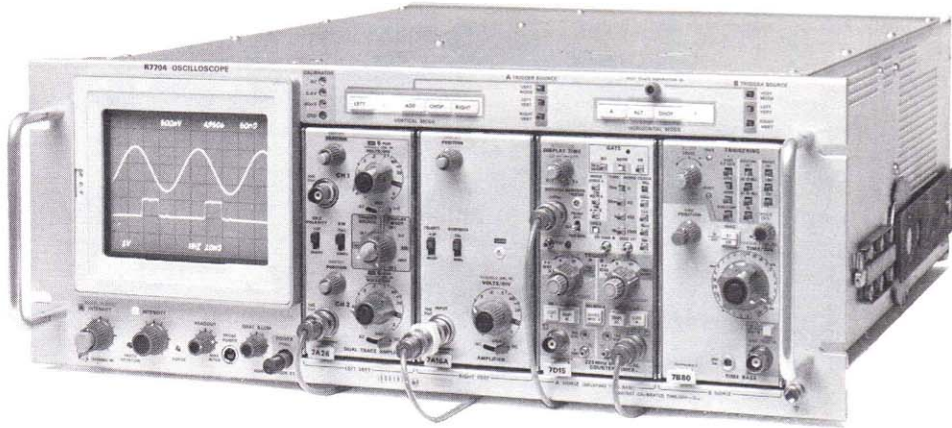

The R7704 requires 7 inches of rack height and offers 175 MHz bandwidth.

Option 04, Max Brightness CRT with Reduced Area (7704A Only) — Internal 4 x 5 cm graticule with variable illumination. Accelerating potential is 24 kV with P31 Phosphor standard, P11 optional. This provides extremely high photographic and information writing speed and increases the visibility of low-rep-rate, high-speed signals.

Option 78, P11 Phosphor Minimum Photographic Writing Speed (Using Polaroid Film Type 612 20,000 ASA without Film Fogging) — Can be increased by using the TEKTRONIX Writing Speed Enhancer. In typical applications, P31 Phosphor has approximately one-half the writing speed of P11 Phosphor. See chart on page 161 for further information.

Autofocus — Reduces the need for additional manual focusing with changes in intensity after focus control has been set.

Beam Finder — Limits display within graticule area.

External Z-Axis Input (7704A only) — 2 V p-p for full intensity range. A positive signal blanks the trace. Max input voltage is 15 V (dc + peak ac) and p-p ac. Input is dc-coupled.

External Z-Axis Input (R7704 only) — High sensitivity input; minimum pulse width to blank trace is 30 ns at 2 V; 2 V p-p for full intensity range from dc to 2 MHz; intensity range diminishes to 20% of full range at 10 MHz. A positive signal blanks the trace; input R is 500 Ω within 10%. Max input voltage is 15 V (dc + peak ac) and p-p ac.

High Speed Input — Minimum pulse width to blank trace is 3.5 ns at 60 V; 60 V p-p for full intensity range from dc to 100 MHz. A positive signal blanks the trace; input R is 18 k Ω within 20%. Max input voltage is 60 V (dc + peak ac) and p-p ac.

OUTPUTS/INPUTS

+Sawtooth — Sawtooth starts 1 V or less from ground (into 1 M Ω). Internally selectable from A or B horizontal. Output voltage is 50 mV/div ($\pm 15\%$) into 50 Ω , 1 V/div ($\pm 10\%$) into 1 M Ω . Output R is 950 Ω nominal.

+Gate — Positive-going rectangular waveform derived from A, B, or Delayed Gate, internally selectable. Output voltage is 0.5 V ($\pm 10\%$) into 50 Ω , 10 V ($\pm 10\%$) into 1 M Ω . Rise time is 20 ns or less into 50 Ω ; output R is 950 Ω nominal.

Sig Out — Selected by B TRIGGER SOURCE switch. Output voltage is 25 mV/div into 50 Ω , 0.5 V/div into 1 M Ω . The bandwidth depends upon vertical plug-in; see Vertical System Specifications Chart. Output R is 950 Ω nominal.

External Single-sweep Reset — Ground closure, rear-panel input to reset sweep.

Camera Power — Three-prong connector to the left of the CRT provides power, ground, and remote single-sweep reset access for the C-50 Series Cameras.

Probe Power — Two rear-panel connectors provide correct operating voltages for two active probes. R7704 connectors are located on both the front and rear panels. Probe power is deleted on Option 01 of 7704A.

CALIBRATOR

Voltage Output — Rectangular waveshape, positive-going from ground (40 V and 4 mV available when selected by internal jumper). Ranges are 40 mV, 0.4 V, 4 V into 1 M Ω ; 20 mV, 0.2 V, 0.4 V into 50 Ω . Amplitude accuracy is within 1% ($+15^\circ\text{C}$ to $+35^\circ\text{C}$); within 2% (0°C to $+50^\circ\text{C}$). Repetition rate is 1 kHz within 0.25% ($+15^\circ\text{C}$ to $+35^\circ\text{C}$); within 0.5% (0°C to 50°C).

Current Output — 40 mA rectangular waveshape with optional current-loop accessory (012-0259-00) connected between 4 V and gnd pin jacks.

POWER REQUIREMENTS

Line Voltage Ranges — 90 to 132 V ac and 180 to 264 V ac.

Line Frequency — 48 to 440 Hz (7704A) 48 to 66 Hz (R7704).

Option 05, Line Frequency Change (50-400 Hz) — Converts the R7704 to 50-400 Hz operation (not required for 7704A).

Max Power Consumption — 180 W, 2.5 A at 115 V line, 60 Hz (7704A); 225 W, 2.8 A at 115 V line, 60 Hz (R7704).

Included Accessories — For 7704A: 20 in cable, two-pin-to-BNC, (175-1178-00). For R7704: 42 in BNC 50 Ω cable (012-0057-01); 20 in cable, two-pin-to-BNC (175-1178-00); rack-mounting hardware.

Weights and Dimensions — See page 153.

For Recommended Cameras — see page 154.

For Recommended Plug-ins — See page 152.

ORDERING INFORMATION

(Plug-ins not included)

| | |
|--------------------------|--------|
| 7704A Oscilloscope | \$3995 |
| R7704 Oscilloscope | \$6665 |

7704A OPTIONS

| | |
|---|-----------|
| Option 01 Without CRT Readout and Probe Power | Sub \$300 |
| Option 03 Emc Modification | Add \$300 |
| Option 04 Max Brightness CRT with 4x5 cm Display (Specify Phosphor) | Add \$500 |
| Option 09 Bandwidth Change (250 MHz) | Add \$500 |
| Option 78 P11 Phosphor | Add \$35 |

R7704 OPTIONS

| | |
|---|-----------|
| Option 01 Without CRT Readout | Sub \$300 |
| Option 02 X-Y Horiz Comp | Add \$250 |
| Option 03 Emc Modification | Add \$300 |
| Option 05 Line Freq Change (50-400 Hz) (not required for 7704A) | Add \$300 |
| Option 78 P11 Phosphor | Add \$35 |

7704A CONVERSION KITS

| | |
|---|-------|
| 040-0613-00 CRT Readout and Probe Power | \$480 |
| 040-0612-00 Emc Modification | \$400 |
| 040-0619-01 Sig Out/In | \$115 |

R7704 CONVERSION KITS

| | |
|------------------------------------|-------|
| 040-0533-01 CRT Readout | \$130 |
| 040-0529-00 X-Y Horiz Comp | \$260 |
| 040-0562-00 Emc Modification | \$275 |

INTERNATIONAL POWER CORD AND PLUG OPTIONS

| | |
|--|-----------|
| Option A1 Universal Euro 220 V/16A | No Charge |
| Option A2 UK 240 V/13A | No Charge |
| Option A3 Australian 240 V/10A | No Charge |
| Option A4 North American 240 V/15A | No Charge |

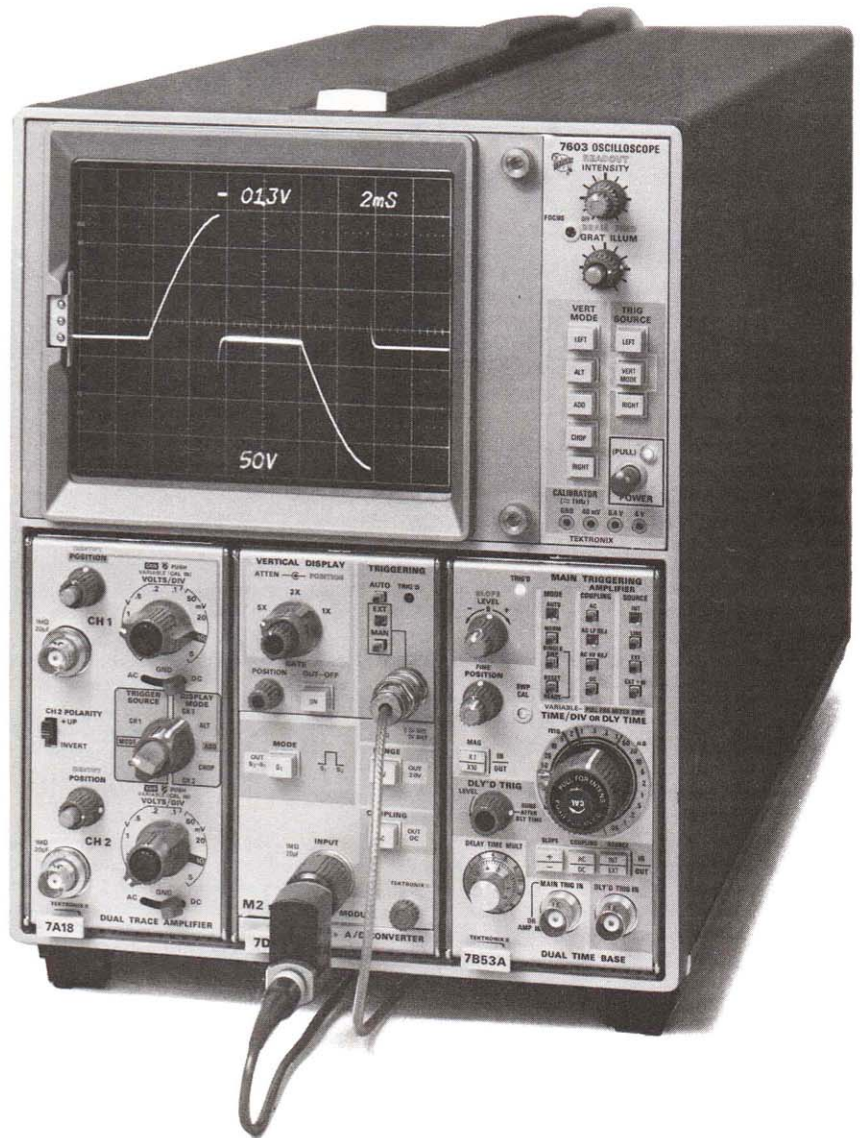

7603 R7603

Dc to 100 MHz Bandwidth

3.5 ns Risetime

6.5 in CRT

CRT Readout

5.25 in Rackmount

APPLICATIONS

Digital Design and Testing

Communications

Spectrum Analysis

The TEKTRONIX 7603 and R7603 Oscilloscopes represent the best price/performance ratio available in the 100 MHz plug-in oscilloscope market today.

The CRT is large, 8 x 10 div (1.22 cm/div), and features an internal graticule with variable illumination and 15 kV accelerating potential. An optional maximum brightness CRT with a smaller 8 x 10 cm display and 18 kV potential gives you greater visual brightness and higher photographic writing speed.

VERTICAL SYSTEM

Channels — Two left-hand plug-in compartments; compatible with all 7000 Series Plug-ins. Bandwidth determined by main-frame and plug-in unit; see Vertical System Specifications Chart.

Modes of Operation — LEFT, ALT, ADD, CHOP, RIGHT.

Chopped Mode — Repetition rate is ≈ 1 MHz.

Delay Line — Permits viewing leading edge of displayed waveform.

HORIZONTAL SYSTEM

Channels — One right-hand plug-in compartment; compatible with all 7000 Series Plug-ins.

Fastest Calibrated Sweep Rate — 5 ns/div.

X-Y Mode — The phase shift between vertical and horizontal channels is within 2° from dc to 35 kHz. Bandwidth is dc to at least 2 MHz.

CRT AND DISPLAY FEATURES

Standard — Internal 8 x 10 div (1.22 cm/div) graticule with variable illumination. Accelerating potential is 15 kV with P31 Phosphor.

Option 01, Without CRT Readout — No CRT readout.

Option 04, Max Brightness CRT With Reduced Area — Internal 8 x 10 cm graticule with variable illumination. Accelerating potential is 18 kV with P31 Phosphor standard.

Option 06, Spectrum Analyzer Graticule.

Optional Phosphors (Specify) — P7, P11, or P7/SA, (Phosphor/Spectrum Analyzer graticule combination.)

Minimum Photographic Writing Speed — Using Polaroid film without film fogging can be increased by using the Tektronix Writing Speed Enhancer.

| CRT | Writing Speed div/ μ s | | Camera | Lens |
|---|----------------------------|-----|--------|-------|
| | Type 612 | | | |
| | P31 | P11 | | |
| Standard 8 x 10 div (1.22 cm/div) | 100 | 150 | C-50 | f/1.9 |
| Option 04 8 x 10 div (1 cm/div) | 200 | 300 | | 1:0.7 |



The R7603 requires only 5.25 in of rack height in a standard 19 in rack. It is fan cooled and comes complete with slide-out chassis tracks.

External Z-Axis Input — 2 V p-p for full intensity range from dc to 2 MHz; intensity range diminishes to 20% of full range at 10 MHz. A positive signal blanks the trace. Max input voltage is 10 V (dc + peak ac) and p-p ac.

Autofocus — Reduces the need for additional manual focusing with changes in intensity after focus control has been adjusted.

Beam Finder — Limits display within graticule area.

OUTPUTS/INPUTS

+Sawtooth — Sawtooth starts 1 V or less from ground (into 1 M Ω). Output R is 950 Ω . Output voltage is 1 V/div ($\pm 10\%$) into 1 M Ω , 50 mV/div ($\pm 15\%$) into 50 Ω .

+Gate — Positive pulse of the same duration and coincident with sweep. Output R is 950 Ω . Output voltage is 10 V ($\pm 10\%$) into 1 M Ω , 0.5 V ($\pm 10\%$) into 50 Ω . Rise time is 20 ns or less into 50 Ω . Source is selectable from Main, Delay, or Auxiliary Gate.

Sig Out — Selected by TRIGGER SOURCE switch. Output voltage is 0.5 V/div into 1 M Ω , 25 mV/div into 50 Ω . Output R is 950 Ω . Bandwidth depends upon vertical plug-in; see Vertical System Specifications Chart.

External Single-sweep Reset — Ground closure, rear panel BNC provides input to reset sweep.

Single-sweep Ready Indicator — Rear panel BNC provides 5 V for single-sweep ready condition.

CAMERA POWER OUTPUT

Three-prong connector to the left of the CRT provides power, ground, and remote single-sweep reset access for the C-50 Series Cameras.

CALIBRATOR

Voltage Output — Rectangular waveshape, positive-going from ground (dc voltage available when selected by internal jumper). Ranges are 40 mV, 0.4 V, 4 V into 1 M Ω ; 20 mV, 0.2 V, 0.4 V into 50 Ω . Amplitude accuracy is within 1% ($+15^\circ\text{C}$ to $+35^\circ\text{C}$); within 2% (0°C to $+50^\circ\text{C}$). Repetition rate is ≈ 1 kHz.

Current Output — 40 mA rectangular waveshape (dc current available when selected by internal jumper) with optional current-loop accessory (012-0259-00) connected between 4 V and gnd pin jacks.

POWER REQUIREMENTS

Line Voltage Ranges — 100, 110, 120, 200, 220, and 240 V ac $\pm 10\%$; internally selectable with quick-change jumpers.

Line Frequency — 50 Hz to 60 Hz (R7603 and 7603).

Option 05, Line Frequency Change (50-400 Hz) — Converts the R7603 and 7603 to 50-400 Hz operation.

Max Power Consumption — 180 W, 2.0 A at 115 V line, 60 Hz. Cooling is provided by a fan.

Included Accessories — (For 7603 and R7603) 20 in cable (two-pin-to-BNC) (175-1178-00); CRT filter (Blue 337-1700-01, Clear 337-1700-04). The R7603 includes rackmounting hardware.

Dimensions and Weights — See page 153.

For Recommended Cameras — See page 154.

For Recommended Plug-ins — See page 152.

ORDERING INFORMATION

(Plug-ins not Included)

| | |
|--------------------------|--------|
| 7603 Oscilloscope | \$2555 |
| R7603 Oscilloscope | \$2955 |

7603 OPTIONS

| | |
|--|-----------|
| Option 01 Without CRT Readout | Sub \$300 |
| Option 03 Emc Modification | Add \$300 |
| Option 04 Max Brightness CRT With 8 x 10 cm Display (specify phosphor) | Add \$350 |
| Option 05 Line Freq Change (50-400 Hz) | Add \$300 |
| Option 06 With Internal Spectrum Analyzer Graticule | Add \$50 |
| Option 08 Protective Panel Cover | Add \$100 |

R7603 OPTIONS

| | |
|--|-----------|
| Option 01 Without CRT Readout | Sub \$300 |
| Option 03 Emc Modification | Add \$300 |
| Option 04 Max Brightness CRT With 8 x 10 cm Display (specify phosphor) | Add \$350 |
| Option 05 Line Freq Change (50-400 Hz) | Add \$300 |
| Option 06 With Internal Spectrum Analyzer Graticule | Add \$50 |

7603 CONVERSION KITS

| | |
|---|--------|
| 040-0654-02 CRT Readout* | \$1000 |
| 040-1000-00 Emc Modification | \$230 |
| 040-0629-01 Sig Out/In | \$560 |
| 040-0686-01 Power Supply to Light Plug-in Pushbuttons | \$60 |
| 040-0718-00 X-Y Horiz Comp | \$410 |

R7603 CONVERSION KITS

| | |
|---|--------|
| 040-0674-02 CRT Readout | \$1000 |
| 040-0955-00 Emc Modification | \$100 |
| 040-0633-00 Sig Out/In | \$285 |
| 040-0686-01 Power Supply to Light Plug-in Pushbuttons | \$60 |
| 040-0718-00 X-Y Horiz Comp | \$410 |

PHOSPHOR OPTIONS (7603/R7603)

| | |
|---|----------|
| Option 76 P7 Phosphor | Add \$35 |
| Option 77 P7 Phosphor with Internal Spectrum Analyzer Graticule | Add \$35 |
| Option 78 P11 Phosphor | Add \$35 |

*Not Available for 7603N11S.

7603N11S

Ruggedized for Extreme Environments

Meets or Exceeds MIL-O-24311 (EC)
(AN/USM-281C Specifications)

Large, Bright Display - 6.5 in CRT (15 kV)

5 ns/div Delaying Sweep

0.5 mV Vertical Sensitivity

Three-plug-in Flexibility

Versatile Trigger-Source Selection

Pushbutton Switching

Illuminated No-Parallax Graticule

Color-keyed Panels

Protective Cover with Accessories

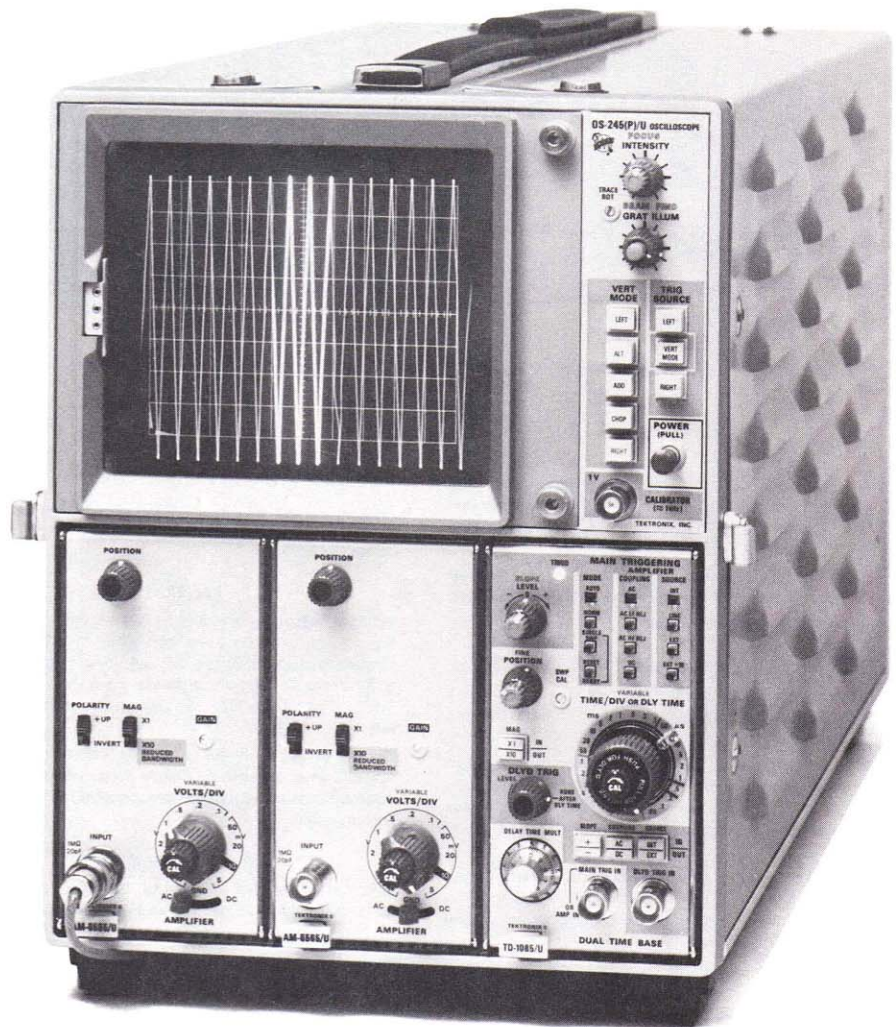

The 7603N11S Ruggedized Oscilloscope System meets the rigid environmental and electrical specifications required by MIL-O-24311 (EC) and appears on U.S. Navy QPL-24311. The system consists of a three plug-in mainframe, two single-trace amplifiers, a dual time base, and a front-panel cover with probes and accessories.

Although the military spec requires only 50 MHz performance, this system actually performs to 65 MHz. Other better-than-required specs include operating altitude, sensitivity at reduced operating altitude, sensitivity at reduced bandwidth with 10X gain, "X" sensitivity in X-Y mode, triggering frequency range, delaying and delayed sweep speeds, and CRT size.

The mainframe and plug-ins are compatible with the Tektronix 7000 Series product line. The system does not have CRT readout, and it can't be used with the digital plug-ins.

ENVIRONMENTAL

Temperature — Nonoperating -62°C to $+75^{\circ}\text{C}$, operating -28°C to $+65^{\circ}\text{C}$.

Humidity — 0 to 95% rh over entire temperature range, operating or nonoperating.

Altitude — Nonoperating sea level to 50,000 ft, operating sea level to 15,000 ft.

Vibration (Operating) — 5 to 15 Hz at 0.060 in \pm 0.012 in p-p amplitude, 16 to 25 Hz at 0.040 in \pm 0.008 in p-p amplitude, 26 to 33 Hz at 0.020 in \pm 0.004 in p-p amplitude.

Shock (Operating) — 9 consecutive 400 pound hammer blows without failure from 1, 3, and 5 ft in vertical, horizontal, and longitudinal axis as per MIL-S-901 for Grade A, Class 1, Type A for lightweight equipment.

Inclination (Operating) — As per MIL-E-16400.

Drip Proof (Nonoperating) — As per MIL-STD-198

Salt Spray (Nonoperating) — As per MIL-E-16400.

Electromagnetic Interference — As per MIL-STD-462 performed by MIL-STD-461 for the following tests:

| | | |
|-------|-------------------|--------------------------------------|
| CE-01 | 30 Hz to 20 kHz | Power lead emission |
| CE-03 | 20 kHz to 50 MHz | Power lead emission |
| CS-01 | 30 Hz to 50 kHz | Power lead, radiation susceptibility |
| CS-02 | 50 kHz to 400 MHz | Power lead, radiation susceptibility |
| CS-06 | Spike Test | Power lead, spike susceptibility |
| RE-01 | 30 Hz to 30 kHz | Instrument radiation, magnetic |
| RE-02 | 14 kHz to 10 GHz | Instrument radiation, electric |
| RS-01 | 30 Hz to 30 kHz | Instrument susceptibility, magnetic |
| RS-03 | 14 kHz to 10 GHz | Instrument susceptibility, electric |

Reliability — Optimum performance and reliable service are provided during continuous or interrupted operation. The MIL-O-24311(EC) MTBF requirement of >600 hours is met as tested under the following conditions: temperature +40°C ±2°C; relative humidity 70% ±5%; vibration 25 Hz at 0.040 in ±0.008 in p-p amplitude for 10 minutes of each "Power On" hour during each day of the 8 hour manned schedule; power cycled at 4 hour intervals with 10 minutes power off for each 4 hour period of the manned test schedule. An MTBF of >2000 hours was achieved during testing.

VERTICAL SYSTEM

(Includes Two 7A15AN11 Plug-ins)

Channels — Two left-hand plug-in compartments, with a delay line which allows the leading edge of the displayed waveform to be viewed. All 7000 Series Plug-ins are compatible (except those which require CRT readout).

Display Modes — LEFT, ALT, ADD, CHOP, RIGHT, Chopped frequency is ≈1 MHz. Added mode displays signals algebraically with a cmrr of 20:1 to 25 MHz.

Bandwidth/Sensitivity — Dc to 65 MHz from 5 mV/div to 10 V/div, accuracy within 2%, variable extends to 25 V/div. Max sensitivity is 0.5 mV at 10 MHz with 10X gain. Ac-coupling lower -3 dB point is <2 Hz. Rise time is 5.4 ns with <2% aberrations.

Input R and C — 1 MΩ within 2%, <27 pF.

Max Input Voltage — 400 V (dc + peak ac).

Dc Stability — <1 div/hr drift at 25°C.

HORIZONTAL SYSTEM

(Includes One 7B53AN11 Plug-in)

Channels — One right-hand plug-in compartment. All 7000 Series Plug-ins are compatible (except those which require CRT readout).

Internal Trigger Modes — LEFT VERT, VERT MODE, RIGHT VERT.

X-Y Mode — The phase shift between vertical and horizontal channels is <2° from dc to 35 kHz. Bandwidth is at least 2 MHz. Rise time is <175 ns. Using the 7B53AN11 Time-Base external amplifier, 10 mV, 100 mV, and 1 V sensitivities (±10%) are available. Input R and C for 7B53AN11 is 1 MΩ within 2%, 20 pF within 2 pF. Any vertical plug-in, such as the 7A15AN11, may be used in the horizontal compartment, providing a greater number of sensitivities for calibrated X-Y displays.

Sweep Display Modes — Main Sweep, Main Sweep Intensified by Delayed Sweep, Delayed Sweep.

MAIN (DELAYING) SWEEP

Sweep Rate — 0.05 μs/div to 5 s/div in 25 steps (1-2-5 sequence). 5 ns/div fastest calibrated sweep rate, obtained with X10 magnifier. The uncalibrated variable is continuous between steps and to 12.5 s/div.

Sweep Accuracy — Within 3% from 0.05 μs/div to 5 s/div, within 5% at 5 ns/div.

Sweep Modes — Normal, Auto, Single Sweep.

Delay Time — Multiplier range is 0 to 10 times the Time/Div setting. Accuracy is within 1% from 0.5 s/div to 0.5 μs/div, within 2% from 5 s/div to 1 s/div. Incremental linearity is within 0.2% of full scale. Jitter is <1 part in 20,000 of 10X time/div setting.

Triggering (Source/Sensitivity) — Internal 0.5 cm to 50 MHz. External, 0.25 V to 20 MHz, 0.5 V to 50 MHz. Ext ÷ 10, 2.5 V to 20 MHz, 5 V to 50 MHz. Triggering extends to 100 MHz with reduced sensitivity in both Internal and External Modes. Input R and C is 1 MΩ within 2%, 20 pF within 2 pF.

Triggering Frequency Range — Ac, 30 Hz to 50 MHz; ac If Rej. 30 kHz to 50 MHz; ac hf Rej. 30 Hz to 50 kHz; dc, dc to 50 MHz. With external level range, slope is ±30 V.

DELAYED SWEEP

Triggering (Source/Sensitivity) — Internal 0.3 div to 10 MHz increasing to 1.5 div at 50 MHz. External, 0.1 V to 10 MHz increasing to 0.5 V at 100 MHz. Input R and C is 1 MΩ within 2%, 20 pF within 2 pF.

Triggering Frequency Range — Ac, 30 Hz to 50 MHz; dc 30 Hz to 50 MHz.

Sweep Rate — 0.05 μs/div to 0.5 s/div in 22 steps (1-2-5 sequence). The delayed sweep runs after delay time or is triggerable after delay time.

Sweep Accuracy — Within 3% from 50 ms/div to 0.5 μs/div, within 4% for all other sweep rates except the magnified X10 sweep rate of 5 ns/div, which is within 6%.

CRT

Accelerating Potential — 15 kV.

Phosphor — P31.

Graticule — Internal 8 x 10 cm with variable illumination. The 6.5 in CRT permits 2 cm of linear overscan in both axes, making a total viewing area of ≈10 x 12 cm.

CRT Controls — Located on front panel are Focus, Intensity, Graticule Illumination, Beam Finder, and Trace Rotation. Astigmatism is an internal control.

External Z-Axis Input (BNC Connector on Rear Panel) — 2 V p-p for full intensity range from dc to 2 MHz, intensity range diminishes to 20% of full range at 10 MHz. Max input voltage is 10 V (dB + peak ac).

OUTPUTS

Calibrator (BNC Connector on Front Panel) — 1 V within 1%, 1 kHz squarewave within 20%.

Horizontal — Main Sweep +5 V, Delayed Sweep +5 V, Main Sweep Gate +2 V, Delayed Sweep Gate +2 V, Delayed Trigger +1 V with pulse width of >50 ns. All amplitudes are minimum and measured when working into at least 100 kΩ and 15 pF.

POWER REQUIREMENTS

Input Voltages — 100, 110, 120, 220, and 240 V ac ±10% internally selectable with quick-change jumpers with 47.5 - 440 Hz single phase line frequency. Max power consumption is 125 W.

C281 COVER WITH ACCESSORIES

The cover provides protection during transport and packages the included accessories.

**INCLUDED ACCESSORIES
(All Packaged in Cover)**

The P6006 Probe packages (010-0127-00); two 8 ft long 50 Ω BNC cables (012-0366-00); two BNC female to uhf male adapters (103-0015-00); two BNC male to uhf female adapters (103-0032-00); two BNC male to binding post adapters (103-0033-00) two BNC T connectors (103-0030-00). One set of technical manuals (not packaged in cover).

Dimensions and Weights — See page 153.

For Recommended Cameras — See page 154.

ORDERING INFORMATION

7603N11S Oscilloscope System (AN/USM-281C)
7603NMS \$7160

System Includes — One each 7603N11 Oscilloscope, two each 7A15AN11 Amplifier Plug-ins, one each 7B53AN11 Time Base, and one each C281 Cover with Accessories.

To Order Separately:

7603N11 Oscilloscope* (OS-245(P)/U) \$3510

7A15AN11 Amplifier Plug-in (AM-6565/U)
7A15ANM \$745

7B53AN11 Time Base Plug-in (TD-1085/U)
7B53ANM \$1795

016-0553-00, C281 Cover W/Accessories \$365

*CRT readout not available.

INTERNATIONAL POWER CORD AND PLUG OPTIONS

Option A1 Universal Euro 220 V/16A No Charge
Option A2 UK 240 V/13A No Charge
Option A3 Australian 240 V/10A No Charge
Option A4 North American 240 V/15A No Charge

7000 SERIES CRT STORAGE MAINFRAMES

CONTENTS

| | |
|--|-----|
| 7000 Series Non-Storage Mainframes | 155 |
| 7000 Series Storage Mainframes | 168 |
| Digital Mainframes | 176 |
| Plug-Ins | 183 |

Storage mainframes in the 7000 Series offer a full selection of stored writing speeds: from ≈ 0.03 cm/ μ s for mechanical, spectrum analysis, or TDR applications, to 2500 cm/ μ s for capturing fast single events such as high speed digital logic. A selection of storage modes offers the following features:

- Bistable** Long View Time
- Variable Persistence** High Contrast Displays
- FAST Bistable** Captures Fast Single or Multiple Events
- FAST Variable Persistence** Provides Maximum Stored Writing Rate



7613
Variable
Persistence



7623A
FAST
Multimode

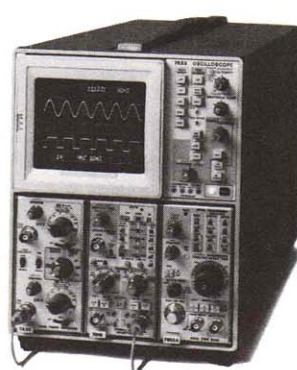

7633
FAST
Multimode



7834
FAST
Multimode

STEP RISE TIME

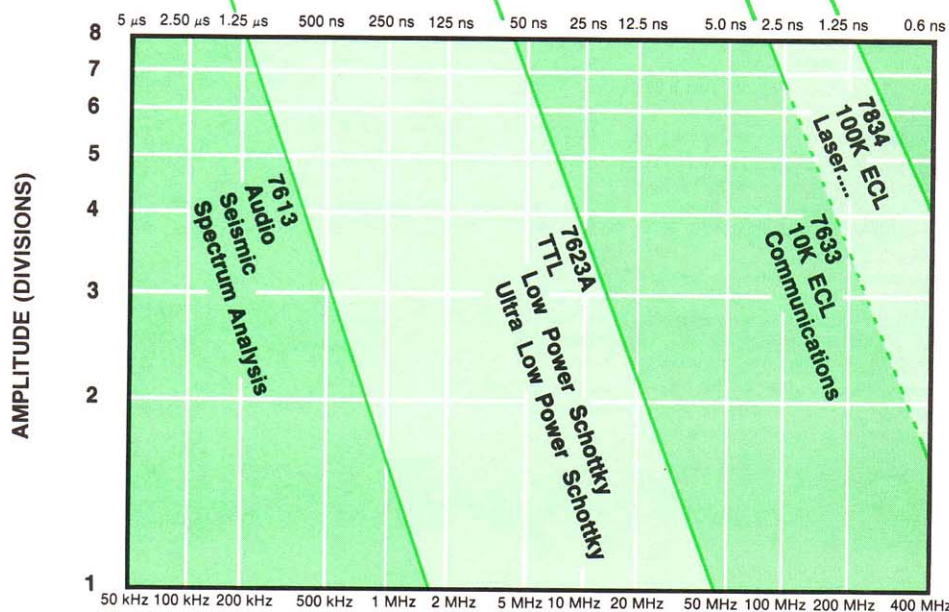

Graph shows the stored writing speed needed to display a given sinewave or step rise time at a given amplitude.

FAST CRT STORAGE

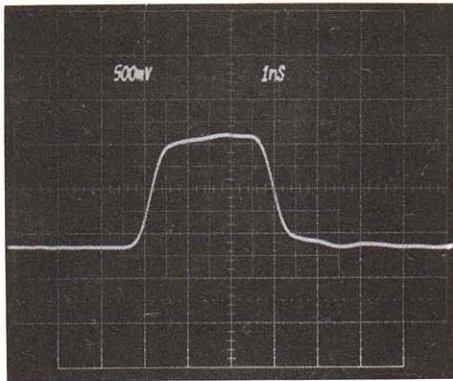

Readout Stored with the Waveform

Fast Stored Writing Speeds

Multimode 7834/7633/7623A

Variable Persistence 7613

7000 Series Storage Oscilloscopes

Storage, as it applies to most instruments in the TEKTRONIX 7000 Series, involves techniques for capturing and retaining signals within the cathode-ray tube itself, or as numeric values in digital memory.

Why Store?

Capturing an event for detailed analysis is perhaps the most obvious application for a storage CRT, but many other situations also call for its unique advantages. Some examples include capturing the entire display of a slowly occurring signal ... observing signal changes during circuit adjustment ... comparing incoming signals with a standard ... increasing the brightness of a repetitive signal for viewing in normal ambient light ... reducing flicker or noise ... baby-sitting, or unattended monitoring for a transient event ... and enhancing other recording techniques such as photography.

Storage Features

Since 1962, when Tektronix introduced phosphor target bistable storage in the 564, techniques for capturing and retaining waveforms have grown at an explosive rate in order to keep pace with measurement demands.

However, the language of storage—such terms as bistable, variable persistence, mesh transfer and digital storage—frequently presents as much confusion as the measurement that must be made.

Characteristics of individual 7000 Series Mainframes employing storage techniques are listed on pages 168 through 182. A review, though, of storage concepts should prepare the reader to evaluate the various alternatives more knowledgeably.

Digital Storage

The fundamental difference between the digital storage scope and the CRT storage scope is the form of storage. Digital scopes store data representing waveforms in a digital memory; CRT storage scopes store waveforms within the CRT.

Bistable CRT Storage

Bistable storage, available as one storage mode on the 7834, 7633 and 7623A Mainframes, employs a mesh between the electron gun and the CRT phosphor. It features bright, long lasting displays with reduced contrast.

Variable Persistence CRT Storage

Variable persistence storage is available in the 7613, 7623A, 7633, and 7834 Mainframes. It features bright, high contrast displays and controlled persistence.

A front-panel persistence knob provides control of the decay (fade-away) rate of the stored image. The rate can be varied from almost instantaneous disappearance to a view time of greater than 15 s in the 7613 (30 s in the 7623A, 7633, and 7834).

Fast Multimode CRT Storage

Fast multimode storage, available in the 7623A, 7633, and 7834, provides four storage modes. The four modes combine the previously discussed bright bistable and variable persistence storage modes with fast bistable and fast variable persistence.

The display characteristics of fast bistable and fast variable persistence are the same as bistable and variable persistence respectively. In either fast storage mode the trace image is first written on a fast mesh, then transferred to a long retention mesh for viewing.

As the name implies, the fast storage mode provides increased storage writing speed. For example, in the reduced scan display mode, the variable persistence writing speed of 5.4 cm/ μ s is increased to 2500 cm/ μ s by selecting fast variable persistence.

7834

2500 cm/ μ s Stored Writing Speed

Stores Single-shot Rise Times as Fast as 1.4 ns

Dc-to-400 MHz Bandwidth

Multimode Storage

Long View Time

APPLICATIONS

Laser Fusion

Digital Design

Radar/Lidar

The 7834 Storage Oscilloscope has a stored writing speed of 2500 cm/ μ s, enabling storage of single-shot rise times to 1.45 ns, 3.6 cm high, at eight-divisions amplitude, reduced-scan mode. The 7834's mainframe bandwidth is 400 MHz (nonstore). The system bandwidth may vary from 160 MHz to 400 MHz depending on the plug-in selected.

This instrument has four storage modes—bistable and variable persistence, FAST bistable and FAST variable persistence.

FAST Variable Persistence provides the maximum stored writing rate of 2500 cm/ μ s (reduced scan). View time is at least 30 s.

FAST Bistable increases bistable writing rates to 350 cm/ μ s (reduced scan).

Bistable provides stored displays with long (30 minute) view time.

Variable Persistence gives high contrast displays of both single-shot and repetitive phenomena. When viewing changing waveshapes, variable persistence provides continuous bright displays of new information as old information fades from the CRT.

The 4 compartment flexibility means that more than one measurement can be performed at the same time without switching plug-ins. The 7834 also offers auto-erase for automatic display updating...a save control for 30 times longer viewing...gated readout which prevents the blooming that tends to occur between sweeps with nongated readout...and an adjustable multitrace delay for varying the viewing time prior to the next sweep in the FAST transfer mode.

The multimode storage unit is designed for single shot, low-rep-rate or fast pulse analysis.

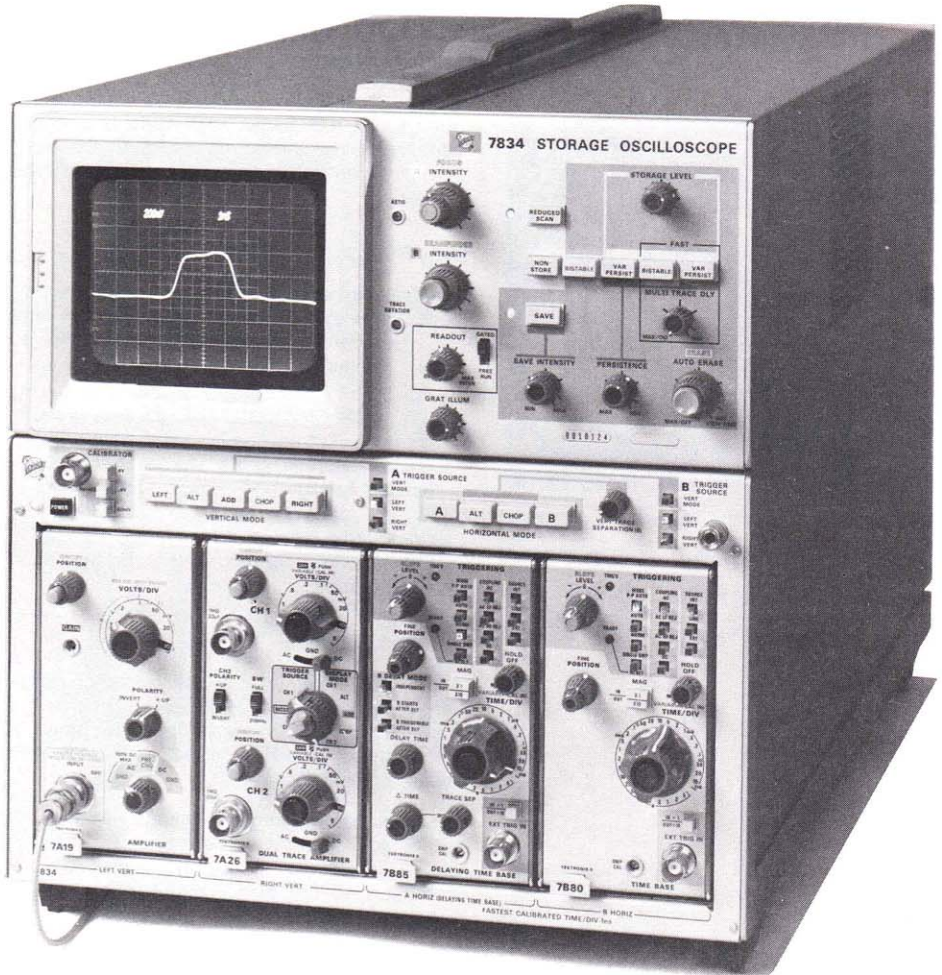

VERTICAL SYSTEM

Channels — Two left-hand plug-in compartments; compatible with all 7000 Series Plug-ins.

Modes of Operation — LEFT, ALT, ADD, CHOP, RIGHT.

Mainframe Bandwidth — 400 MHz with 7A29 Amplifier plug-in.

Mainframe Step Response — 0.9 ns or less with 7A29 Amplifier plug-in.

Chopped Mode — Repetition rate is \approx 1 MHz.

Delay Line — Permits viewing leading edge of displayed waveform (not recommended for use with 7B50 Series Time Bases).

Trace Separation Range — In dual-sweep modes, B trace can be positioned 4 divisions above or below the A trace.

HORIZONTAL SYSTEM

Input — Two right-hand plug-in compartments; compatible with all 7000 Series Plug-ins. 7000 Series Vertical Amplifiers and specialized plug-ins may also be used.

Modes of Operation — A, ALT, CHOP, B.

Fastest Calibrated Sweep Rate — 1 ns/div.

Chopped Mode — Repetition rate is \approx 200 kHz.

X-Y Mode — Phase shift between vertical and horizontal channels is within 2° from dc to 35 kHz without phase correction (dc to 1 MHz with phase correction, B horizontal only, Option 02). Bandwidth is dc to at least 1 MHz.

CRT AND DISPLAY FEATURES

Graticule — Internal variable illuminated graticule. 8 x 10 division (0.9 cm/div) graticule in full scan and 8 x 10 division (0.45 cm/div) in reduced scan.

Option 01, without CRT Readout and Probe Power — Deletes CRT readout and probe power.

Accelerating Potential — \approx 10 kV full scan mode, and 12 kV in reduced scan mode.

Phosphor — P31.

CRT Display Modes — Nonstore, Bistable, Variable Persistence, FAST Bistable and FAST Variable Persistence (full and reduced scan).

Persistence — (Variable Persistence mode only) controls rate of continuous erasure of the variable persistence and fast variable persistence stored displays.

Auto Erase — Continuously variable from $<$ 1 s to $>$ 10 s.

Multitrace Delay — Adjusts the transfer cycle time in the FAST transfer modes. Continuously variable from $<$ 1 s to $>$ 4 s.

Save — Prevents display from being accidentally erased, and provides up to 30 times longer viewing times in all modes.

External Z-Axis Input — 2 V p-p for full intensity range from dc to 1 MHz. Positive signal blanks the trace. Maximum input voltage is 15 V (dc plus peak ac).

Auto-Focus — Maintains CRT focus following changes in display intensity after focus control has been initially set.

Beam Finder — Limits display within graticule.

STORAGE WRITING SPEED

FULL SCAN (Center 6 x 8 div at 0.9 cm/div)

| Display Mode | Fast Variable Persistence | Fast Bistable | Variable Persistence | Bistable |
|----------------------|---------------------------------------|-------------------------------------|-------------------------------------|---|
| Stored Writing Speed | 270 cm/ μ s (300 div/ μ s) | 45 cm/ μ s (50 div/ μ s) | 1.8 cm/ μ s (2 div/ μ s) | 0.027 cm/ μ s (.03 div/ μ s) |
| View Time | 30 s* | 30 min | 30 s* | 30 min |
| Erase Time (Approx) | 1.4 s | 1.4 s | 0.9 s | 0.9 s |

*REDUCED SCAN Center 8 x 10 div at 0.45 cm/div

| Display Mode | Fast Variable Persistence | Fast Bistable | Variable Persistence | Bistable |
|----------------------|--|---------------------------------------|--------------------------------------|--|
| Stored Writing Speed | 2500 cm/ μ s (5,500 div/ μ s) | 350 cm/ μ s (776 div/ μ s) | 5.4 cm/ μ s (12 div/ μ s) | 0.09 cm/ μ s (0.2 div/ μ s) |
| View Time* | 30 s | 30 min | 30 s | 30 min |
| Erase Time* (Approx) | 1.4 s | 1.4 s | 0.9 s | 0.9 s |

*View times are at full stored display intensity; they may be increased more than 30 times by using reduced intensity in the SAVE display mode.

Fast Variable Persistence Writing Speed

| Scan Mode | Sweep Speed | Peak-to-Peak Sine wave | Step Response |
|---|------------------|------------------------|-------------------|
| Reduced Scan 5,500 div/ μ s (0.45 cm/div) | ≥ 1 ns/div | 7.1 div 250 MHz | 7.7 div 1.4 ns |
| | | 8 div 221 MHz | 8 div 1.45 ns |
| Full Scan 300 div/ μ s (0.9 cm/div) | ≥ 10 ns/div | 3.2 div 30 MHz | 3 div 10 ns |
| | | 6.4 div 15 MHz | 5 div 16.6 ns |

OUTPUTS/INPUTS

+Sawtooth — Positive going with baseline at 0 V \pm 1 V into 1 M Ω . Voltage is 1 V/div (\pm 10%) into 1 M Ω , 50 mV/div (\pm 15%) into 50 Ω . Output R is \approx 950 Ω .

+Gate — Positive pulse of the same duration and coincident with sweep. Output voltage is 10 V (\pm 10%) into 1 M Ω , 0.5 V (\pm 10%) into 50 Ω . Output R is \approx 950 Ω . Source is selectable from A Gate, B Gate or A Delayed Gate.

Vertical Signal Out — Selected by A TRIGGER SOURCE switch. Output voltage is 0.5 V into 1 M Ω , 25 mV into 50 Ω . Output R is \approx 950 Ω . Bandwidth depends upon vertical plug-in.

Remote Single Sweep Reset, Remote Save and Remote Erase — Rear panel BNC connector inputs, ground closure activated.

Remote FAST Transfer Gate — TTL compatible. Low to high transition enables high speed target to receive information to be stored; high to low transition initiates transfer from high speed target to storage target.

Camera Power Output — Three-prong connector to the left of the CRT provides power, ground, and remote single-sweep reset access for the C-50 Series Cameras.

Probe Power — Two rear-panel connectors provide operating voltages for two active probes such as P6201.

CALIBRATOR

Voltage Output — Squarewave, positive-going from ground. Ranges are 40 mV, 0.4 V, and 4 V into 100 k Ω ; 4 mV, 40 mV, and 0.4 V into 50 Ω . Amplitude accuracy is within 1%; repetition rate is 1 kHz within 0.25%.

Current Output — 40 mA available through CALIBRATOR output with optional BNC to current loop adapter.

Dimensions and Weight. See page 153.

For Recommended Cameras — See page 154.

For Recommended Plug-ins — See page 152.

POWER REQUIREMENTS

Line Voltage Ranges — 90 V-132 V.
180 V-250 V.

Line Frequency — 48-440 Hz.

Max Power Consumption — 215 Watts.

Included Accessories — Gray CRT filter (installed) (378-0625-02) green CRT filter (378-0625-08); power cord (161-0066-00).

ORDERING INFORMATION

(Plug-ins not Included)

7834 Storage Oscilloscope \$11,000

OPTIONS

Option 01 without CRT Readout and Probe Power Sub \$300

Option 02 X-Y Mode Phase Correction Add \$250

Option 03 Emc Modification Add \$300

For Rackmounting, Cradle

Mount Adapter 040-0560-00 \$385

CONVERSION KITS

CRT Readout, 040-0811-00 \$480

Emc Modification, 040-0880-00 \$440

INTERNATIONAL POWER CORD AND PLUG OPTIONS

Option A1 Universal Euro 220 V/16A No Charge

Option A2 UK 240 V/13A No Charge

Option A3 Australian 240 V/10A No Charge

Option A4 North American 240 V/15A No Charge

STEP RISE TIME (ns)

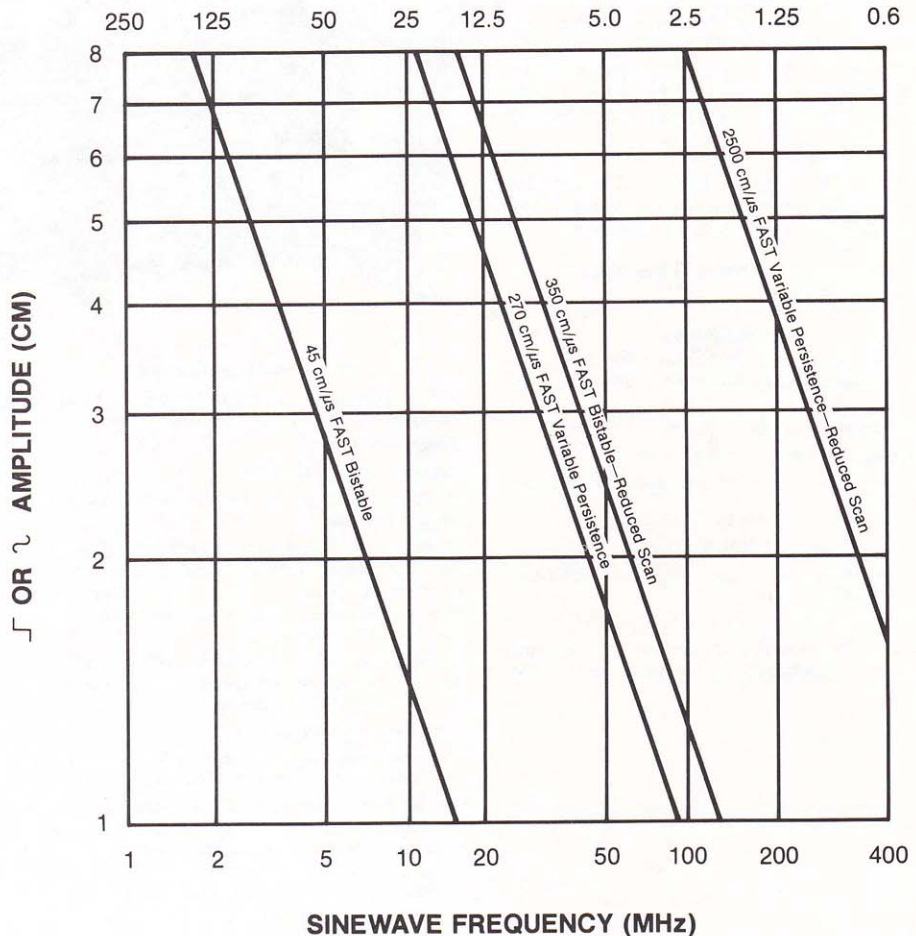

Graph showing the stored writing speed needed to display a given sine wave or step rise time at a given amplitude.

7633

1000 cm/μs Stored Writing Speed

Long View Time

Multimode Storage

Dc-to-100 MHz Bandwidth

APPLICATIONS

Digital Design

Destructive Testing

Communications

The TEKTRONIX 7633 Storage Oscilloscope provides 2200 div/μs (1000 cm/μs) stored writing speed and 100 MHz bandwidth. The instrument has three display modes—store, nonstore, and save—and four storage modes—bistable, variable persistence, fast bistable, and fast variable persistence. The maximum writing speed of 1000 cm/μs (using the center 8 x 10 reduced scan divisions, 0.45 cm/div) is achieved in reduced scan mode.

This multimode storage instrument allows for retention and viewing for fast-rise, low-repetition-rate, single-shot, or slow-moving waveforms.

Characteristics are common to the 7633 and the 7623A unless noted.

VERTICAL SYSTEM

Channels — Two left-hand plug-in compartments; compatible with all 7000 Series Plug-ins. Bandwidth determined by main-frame and plug-in unit.

Modes of Operation — LEFT, ALT, ADD, CHOP, RIGHT.

Chopped Mode — Repetition rate is ≈1 MHz.

Delay Line — Permits viewing leading edge of displayed waveform.

HORIZONTAL SYSTEM

Channel — One right-hand plug-in compartment; compatible with all 7000 Series Plug-ins.

Fastest Calibrated Sweep Rate — 5 ns/div.

X-Y Mode — The phase shift between vertical and horizontal channels is <2° from dc to 35 kHz. Bandwidth is dc to at least 2 MHz.

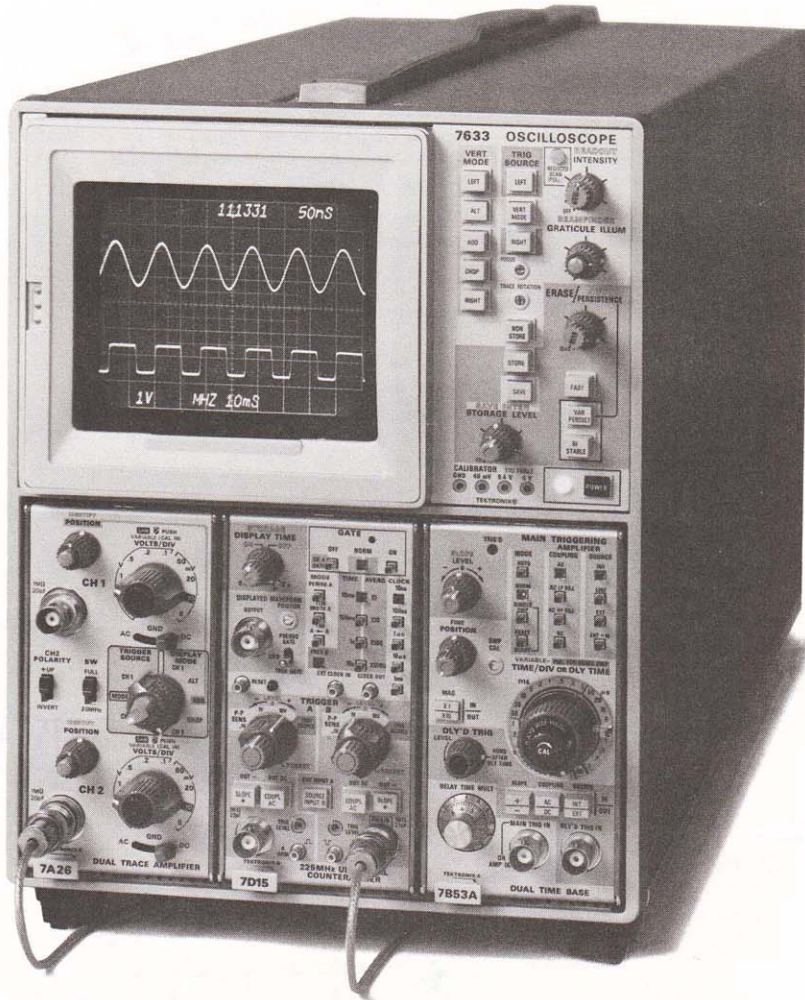

CRT AND DISPLAY FEATURES

CRT — Internal 8 x 10 div (0.9 cm/div) and 8 x 10 div (0.45 cm/div) graticule with variable illumination.

Phosphor — P31.

Option 01 — No CRT readout.

Accelerating Potential — ≈8.5 kV in normal mode, 10 kV in reduced scan mode.

Storage Display Modes — Nonstore, FAST variable persistence, FAST bistable, variable persistence, bistable. Full or reduced scan may be selected on the 7633 in all display modes. Select normal scan to view the entire CRT; select reduced scan for the fastest writing rate.

Persistence — Variable. When set to max, provides the longest retention of high contrast stored displays, without the characteristic fading of variable persistence.

Autoerase — Variable up to 10 s.

Save — Prevents erasing and storing additional displays; also extends view time in variable persistence mode.

External Z-Axis Input — 2 V p-p for useful intensity range from dc to 2 MHz; intensity range diminishes to 20% of full range at 10 MHz. A positive signal blanks the trace. Max input voltage is 10 V (dc + peak ac) and p-p ac.

Autofocus — Reduces the need for calibrated manual focusing with changes in intensity after focus control has been set.

Beam Finder — Limits display within graticule area.

STORAGE WRITING SPEED

Full Scan (7633 and 7623A)

| Display Mode | FAST Variable Persistence | FAST Bistable | Variable Persistence | Bistable |
|----------------------|---------------------------|-----------------|----------------------|-----------------|
| Stored Writing Speed | 135 cm/μs | 45 cm/μs | 0.45 cm/μs | 0.027 cm/μs |
| View Time | 30 s* | 30 min. minimum | 30 s* | 30 min. minimum |
| Erase Time (Approx) | 1.4 s | 1.4 s | 0.9 s | 0.9 s |

Reduced Scan (7633 Only)

| Display Mode | FAST Variable Persistence | FAST Bistable | Variable Persistence | Bistable |
|----------------------|---------------------------|-----------------|----------------------|-----------------|
| Stored Writing Speed | 1000 cm/μs | 180 cm/μs | 1.35 cm/μs | 0.09 cm/μs |
| View Time | 30 s* | 30 min. minimum | 30 s* | 30 min. minimum |
| Erase Time (Approx) | 1.4 s | 1.4 s | 0.9 s | 0.9 s |

*These times are at full stored display intensity; they may be increased more than 30 times by using reduced intensity in the save display mode.

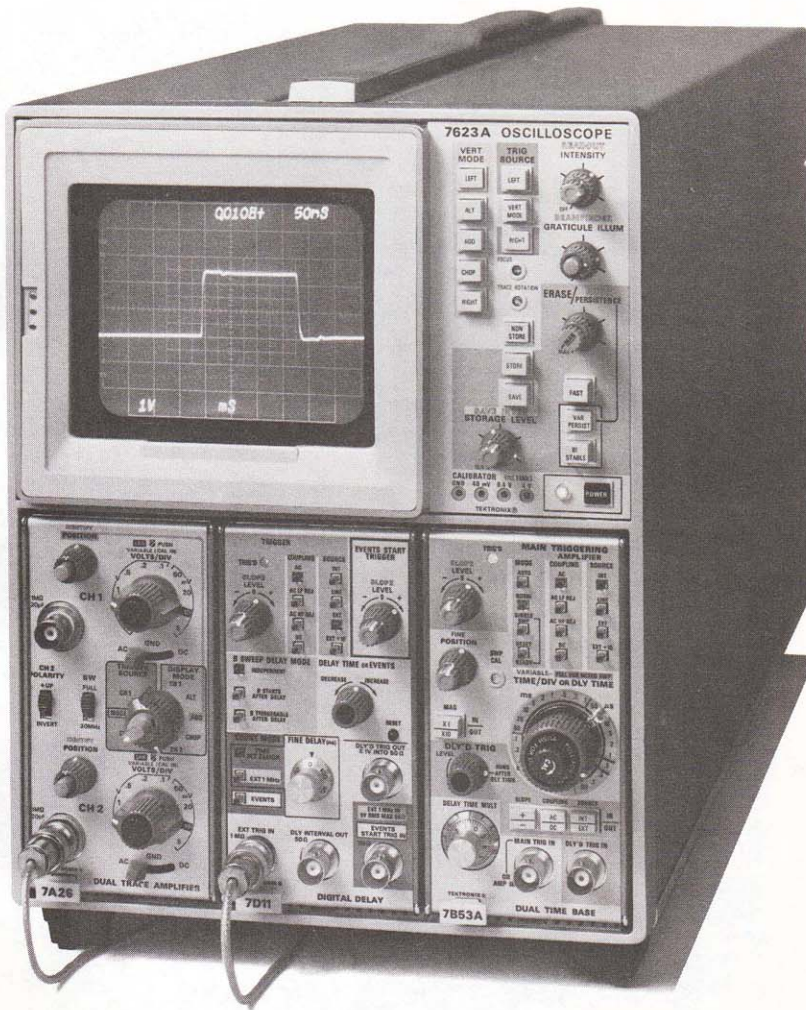

7623A

135 cm/ μ s Stored Writing Speed

Long View Time

Multimode Storage

Dc to 100 MHz Bandwidth

APPLICATIONS

Ultra Sonics

Power Supply Design

Component Testing

The TEKTRONIX 7623A Storage Oscilloscope has all the features and performance of the 7633 except the reduced scan mode.

Fast Variable Persistence Writing Speed

| Scan Mode | Sweep Speed | Peak-to-Peak Sinewave | Step Response |
|--|------------------|-----------------------|-------------------------------|
| Reduced Scan** 2200 div/ μ s (0.45 cm/div) | ≥ 5 ns/div | 7.1 div 100 MHz | 7.7 div 3.5 ns (7633 only) |
| | | 8 div 89 MHz | 8 div 3.7 ns |
| Full Scan 150 div/ μ s (0.9 cm/div) | ≥ 50 ns/div | 3.2 div 15 MHz | 3 div 20 ns 7633 |
| | | 6.4 div | 5 div 7623A |
| | | 7.5 MHz | 33 ns |

**Applies to 7633 only.

STEP RISE TIME (ns)

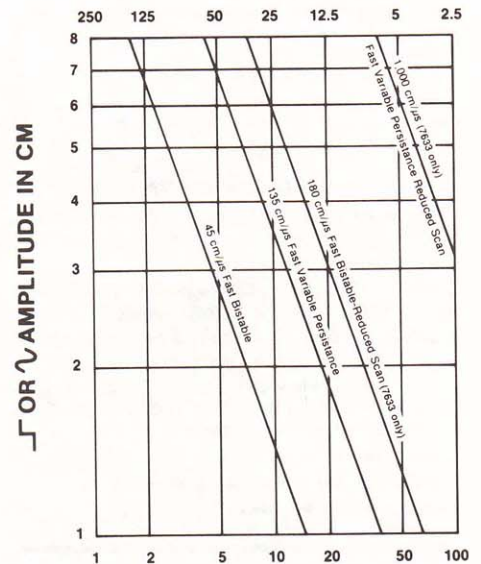

SINE WAVE FREQUENCY (MHz)

Graph showing the stored writing speed needed to display a given sine wave or step rise time at a given amplitude.

OUTPUTS/ INPUTS

+Sawtooth — Sawtooth starts 1 V or less from ground (into 1 M Ω). Output voltage is 50 mV/div ($\pm 15\%$) into 50 Ω , 1 V/div ($\pm 10\%$) into 1 M Ω . Output R is 950 Ω within 2%.

+Gate — Positive pulse of the same duration and coincident with sweep. Output voltage is 0.5 V ($\pm 10\%$) into 50 Ω , 10 V ($\pm 10\%$) into 1 M Ω . Rise time is 20 ns or less into 50 Ω , output R is 950 Ω within 2%. Source is selectable from main, delay, or auxiliary gate.

Vertical Signal Out — Selected by TRIGGER SOURCE switch. Output voltage is 25 mV/div into 50 Ω , 0.5 V/div into 1 M Ω . Bandwidth depends on vertical plug-in. Output R is 950 Ω within 2%.

External Single-Sweep Reset — Ground closure; rear panel BNC provides input to reset sweep.

Remote Erase — Ground closure; rear panel BNC provides input to erase stored trace.

CAMERA POWER OUTPUT

Three-prong connector to the left of the CRT provides power, ground and remote single-sweep reset access for the C-50 Series Cameras.



The R7633 and R7623A require only 5.25 in. of rack height in a standard 19 in rack. They are fan cooled and come complete with slide-out chassis tracks.

CALIBRATOR

Voltage Output — Rectangular waveshape, positive-going from ground (dc voltage available when selected by internal jumper). Ranges are 40 mV, 0.4 V, 4 V into 1 M Ω ; 20 mV, 0.2 V, 0.4 V into 50 Ω . Amplitude accuracy is within 1% (+15°C to +35°C); within 2% (0°C to +50°C) Repetition rate is \approx 1 kHz.

Current Output — 40 mA dc or 40 mA rectangular waveshape with optional current-loop accessory (012-0259-00) connected between 4 V and gnd pin jacks.

POWER REQUIREMENTS

Line Voltage Ranges — 100, 110, 120, 200, 220, and 240 V ac \pm 10%; internally selectable with quick change jumpers.

Line Frequency — 50-60 Hz.

Option 05, Line Frequency Change (50-400 Hz) — Converts the 7633, R7633, 7623A and R7623A to 50-400 Hz operation.

Max Power Consumption — 180 W, 2.0 A at 115 V line, 60 Hz. Fan cooling is provided for both models.

Included Accessories — 20 in cable (two-pin-to-BNC), (175-1178-00); CRT filter, green (378-0625-08). The R7633 and R7623A include rackmounting hardware.

Weights and Dimensions — See page 153.

For Recommended Cameras — See page 154.

For Recommended Plug-ins — See page 152.

ORDERING INFORMATION

(Plug-ins not Included)

| | |
|-----------------------------------|--------|
| 7633 Storage Oscilloscope | \$7295 |
| R7633 Storage Oscilloscope | \$7720 |
| 7623A Storage Oscilloscope | \$5585 |
| R7623A Storage Oscilloscope | \$6005 |

OPTIONS

| | |
|--|-----------|
| Option 01 without CRT Readout | Sub \$300 |
| Option 03 Emc Modification | Add \$300 |
| Option 05 Line Freq Change (50-400 Hz) | Add \$300 |

CONVERSION KITS

| | |
|---|--------|
| CRT Readout (040-0748-01 Cabinet) | \$1000 |
| (040-0759-01 Rackmount) | \$1000 |
| Emc Modification | |
| (040-0663-01 Cabinet) | \$480 |
| (040-0678-01 Rackmount) | \$285 |
| Sig Out/In (040-0629-01 Cabinet) | \$560 |
| (040-0633-00 Rackmount) | \$285 |
| Power Supply to Light Plug-in | |
| Pushbuttons (040-0686-01) | \$60 |

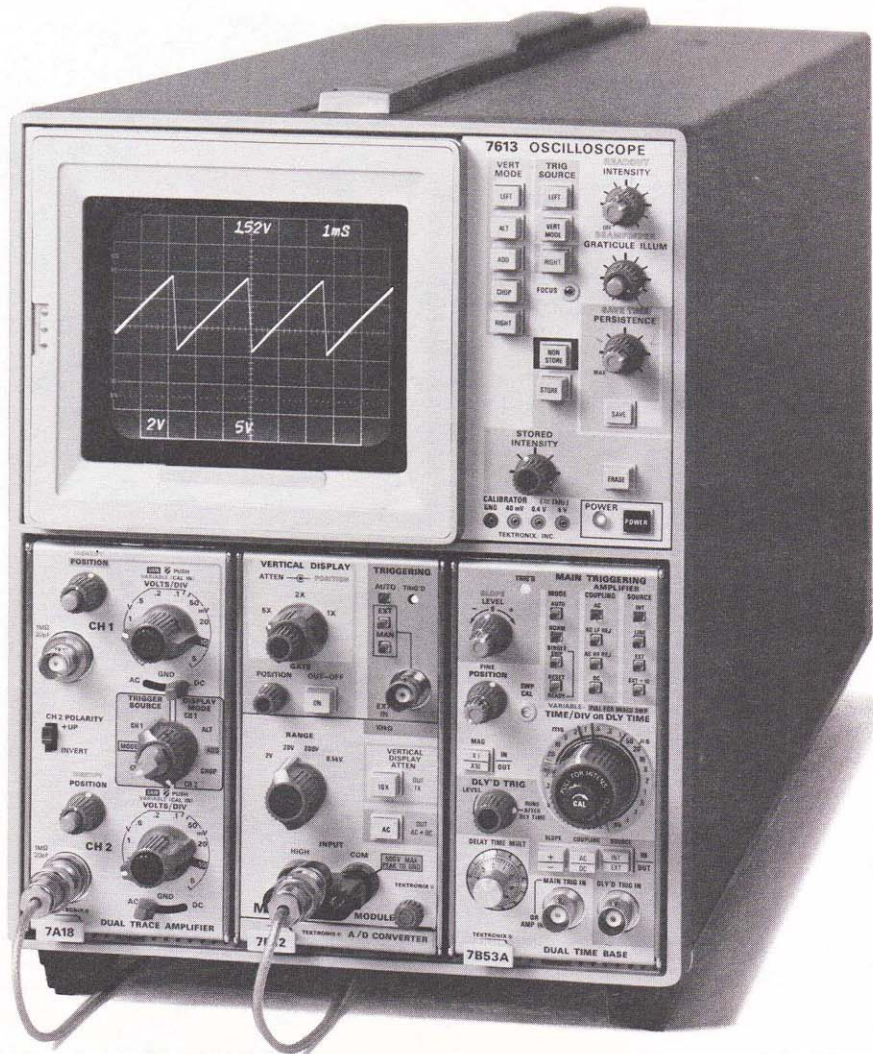

7613

Variable Persistence Storage

4.5 cm/ μ s Stored Writing Speed

Dc to 100 MHz Bandwidth

5.25 in Rackmount Height

APPLICATIONS

Audio

Mechanical Transducers

Spectrum Analysis

The TEKTRONIX 7613 Storage Oscilloscope offers variable persistence operation with a stored writing speed of 5 div/ μ s or non-storage operation. Stored traces may be viewed up to 60 minutes on a display area of 8 x 10 div (0.9 cm/div).

VERTICAL SYSTEM

Channels — Two left-hand plug-in compartments; compatible with all 7000 Series Plug-ins. Bandwidth determined by main-frame and plug-in unit; see Vertical System Specifications Chart.

Modes of Operation — LEFT, ALT, ADD, CHOP, RIGHT.

Chopped Mode — Repetition rate is \approx 1 MHz.

Delay Line — Permits viewing leading edge of displayed waveform.

HORIZONTAL SYSTEM

Channel — One right-hand plug-in compartment; compatible with all 7000 Series Plug-ins.

Fastest Calibrated Sweep Rate — 5 ns/div.

X-Y Mode — The phase shift between vertical and horizontal channels is within 2° from dc to 35 kHz. Bandwidth is dc to at least 2 MHz.

CRT AND DISPLAY FEATURES

Variable Persistence Storage CRT — Internal 8 x 10 div (0.9 cm/div) graticule with variable illumination.

Phosphor — P31.

Option 01 — No CRT readout

Accelerating Potential — 8.5 kV.

Nonstore Mode — For displaying waveforms in the conventional (nonstorage) mode.

Store Mode — For displaying waveforms using the variable persistence storage feature.

Max Stored Writing Speed — > 4.5 cm/μs.

View Time — The view time is the amount of time the stored signal can be viewed before it fades away.

At the max writing speed the view time is 15 seconds or 0.25 minutes with the stored intensity control fully cw. Adjusting the stored intensity ccw will reduce the stored writing speed, but view time can be increased up to 5 minutes (see the chart below).

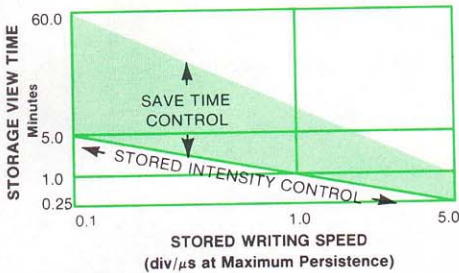

Erase Time — 0.5 s or less.

Persistence — The persistence control also varies the view time. The persistence can be adjusted from almost instantaneous disappearance (fade away), to off, which provides the view time selected by the stored intensity control.

Save — Prevents erasure of the stored display and activates the save time control.

Save Time Control — Allows an extension of the view time (see Storage View Time Chart).

External Z-Axis Input — 2 V p-p for full intensity range from dc to 2 MHz; intensity range diminishes to 20% of full range at 10 MHz. A positive signal blanks the trace. Max input voltage is 10 V (dc + peak ac) and p-p ac.

Autofocus — Reduces the need for additional manual focusing with changes in intensity after focus control has been set.

Beam Finder — Limits display within graticule area.

OUTPUTS/INPUTS

+Sawtooth — Sawtooth starts 1 V or less from ground (into 1 MΩ). Output voltage is 50 mV/div (±15%) into 50 Ω, 1 V/div (±10%) into 1 MΩ. Output R is 950 Ω within 2%.

+Gate — Positive pulse of the same duration and coincident with sweep. Output voltage is 0.5 V (±10%) into 50 Ω, 10 V (±10%) into 1 MΩ. Rise time is 20 ns or less into 50 Ω; output R is 950 Ω within 2%. Source is selectable from main, delay, or auxiliary gate.

Sig Out — Selected by TRIGGER SOURCE switch. Output voltage is 25 mV/div into 50 Ω, 0.5 V/div into 1 MΩ. Bandwidth depends upon vertical plug-in; see Vertical System Specifications Chart. Output R is 950 Ω within 2%.

External Single-Sweep Reset — Ground closure; rear panel BNC provides input to reset sweep.

Remote Erase — Ground closure; rear panel BNC provides input to erase stored trace.

STEP RISE TIME

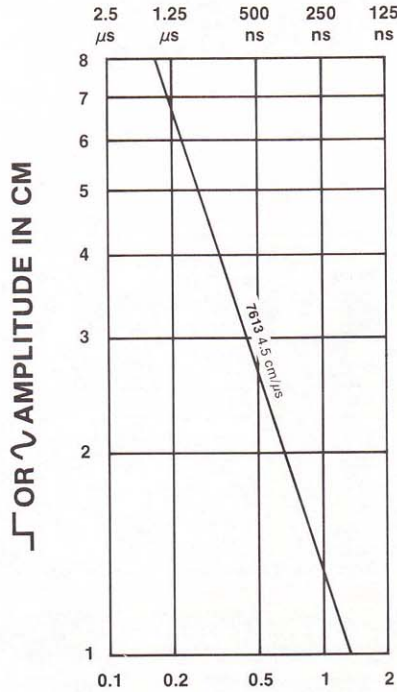

Graph showing the stored writing speed needed for a given sine wave or step rise time at a given amplitude.

CAMERA POWER OUTPUT

Three-prong connector to the left of the CRT provides power, ground, and remote single-sweep reset access for the C-50 Series Cameras.

CALIBRATOR

Voltage Output — Rectangular waveshape, positive-going from ground. (Dc voltage available when selected by internal jumper.) Ranges are 40 mV, 0.4 V, 4 V into 1 MΩ; 20 mV, 0.2 V, 0.4 V into 50 Ω. Amplitude accuracy is within 1% (+15°C to +35°C); within 2% (0°C to +50°C). Repetition rate is ≈ 1 kHz.

Current Output — 40 mA dc or 40 mA rectangular waveshape with optional current-loop accessory (012-0259-00) connected between 4 V and gnd pin jacks.

Line Voltage Ranges — 100, 110, 120, 200, 220, and 240 V ac ± 10%; internally selectable with quick change jumpers.

Line Frequency — 50-60 Hz.

Option 05, Line Frequency Change (50-400 Hz) — Converts the 7613 and R7613 to 50-400 Hz operation.

Max Power Consumption — 180 W, 2.0 A at 115 V line, 60 Hz. Fan cooling is provided for both models.

Included Accessories (for 7613 and R7613) — 20 in cable (two-pin-to-BNC); (175-1178-00); CRT filter (gray, 378-0625-02). The R7613 includes rackmounting hardware.

Dimensions and Weight — See page 153.

For Recommended Cameras — See page 154.

For Recommended Plug-ins — See page 152.

**ORDERING INFORMATION
(Plug-ins not included)**

| | |
|---|---------------|
| 7613 Storage Oscilloscope | \$4680 |
| R7613 Storage Oscilloscope | \$5110 |

7613 OPTIONS

| | |
|--|------------------|
| Option 01 without CRT Readout | Sub \$300 |
| Option 03 Emc Modification | Add \$300 |
| Option 05 Line Freq Change (50-400 Hz) | Add \$300 |
| Option 06 Special Int Graticule (Spectrum Analyzer) | Add \$50 |
| Option 08 Protective Panel Cover | Add \$100 |

R7613 OPTIONS

| | |
|--|------------------|
| Option 01 without CRT Readout | Sub \$300 |
| Option 03 Emc Modification | Add \$300 |
| Option 05 Line Freq Change (50-400 Hz) | Add \$300 |
| Option 06 Special Int Graticule (Spectrum Analyzer) | Add \$50 |

7613 CONVERSION KITS

| | |
|--|---------------|
| 040-0656-02 CRT Readout | \$1000 |
| 040-0663-01 Emc Modification | \$480 |
| 040-0718-00 X-Y Horizontal Comp | \$410 |
| 040-0629-02 Sig Out/In | \$535 |
| 040-0686-01 Power Supply to Light Plug-in Pushbuttons | \$60 |

R7613 CONVERSION KITS

| | |
|--|---------------|
| 040-0676-02 CRT Readout | \$1000 |
| 040-0678-01 Emc Modification | \$285 |
| 040-0686-01 Power Supply to Light Plug-in Pushbuttons | \$60 |

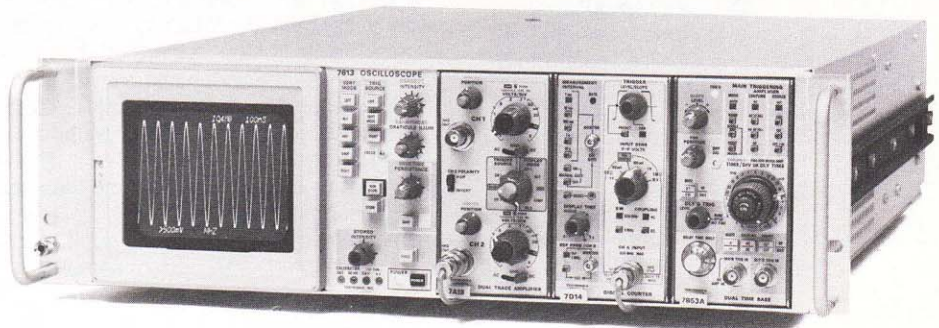

The R7613 requires only 5 1/4 in of rack height in a standard 19 in rack. It is fan cooled and comes complete with slide-out chassis tracks.

7000 SERIES DIGITAL MAINFRAMES

CONTENTS

| | |
|---|-----|
| 7854 Waveform Processing Oscilloscope ... | 177 |
| 7612D Programmable Waveform Digitizer .. | 179 |
| 7912AD Programmable Waveform Digitizer | 181 |
| 7000 Series Reference | 148 |
| 7000 Series Non-Storage Mainframes | 155 |
| 7000 Series CRT Storage Mainframes | 168 |
| 7000 Series Plug-Ins | 183 |

IEEE-488 COMPATIBLE

Especially designed for precise automatic waveform measurements in demanding applications in R&D and production environments.

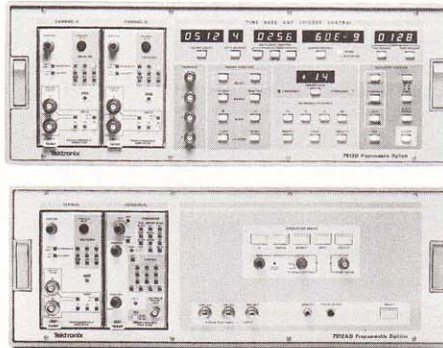

7000 Series Digital Mainframes offer wide performance capabilities suited to today's demanding measurement needs. Depending on mainframe, capture high or low speed signals that are repetitive or single shot. Configure mainframes to your individual needs from a choice of over 30 plug-ins. The 7854 combines outstanding analog and digital performance with microprocessor-based waveform processing whereas the 7612D and 7912AD combine outstanding analog and digital performance with full programmability. All mainframes are fully GPIB compatible.

Digital Storage

The fundamental difference between the digital storage scope and the CRT storage scope is the form of storage. Digital scopes store data representing waveforms in a digital memory; CRT storage scopes store waveforms within the CRT. Digital storage requires digitizing and reconstruction processes. "Digitizing" consists of "sampling" and "quantizing." Sampling is the process of obtaining the value of an input signal at discrete points in time; quantizing is the transformation of that value into a binary number by the analog-to-digital converter (ADC) in the digital scope. You determine how often digitizing occurs by the time base. The time base uses a digital clock to time the analog-to-digital (A/D) conversion and to store the data in memory. The rate at which this happens is the digitizing rate (or sampling rate).

Once the data is in the digital memory, it can be read out and reconstructed for displaying or further waveform processing.

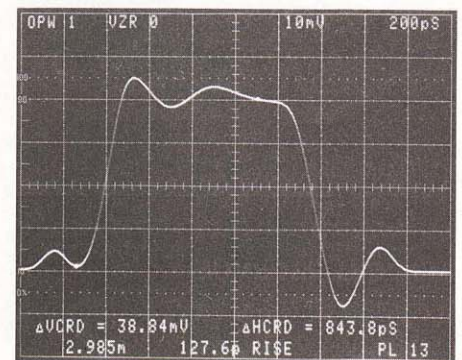
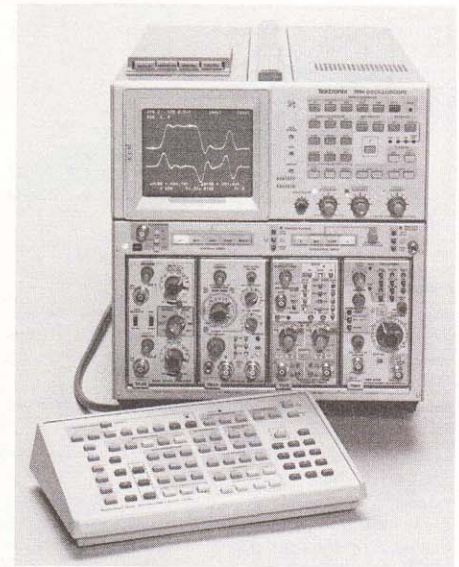

Store Repetitive Signals up to 400 MHz with Standard Plug-ins, and up to 14 GHz with the 7S12 Sampler

Digital Storage with Waveform Processing

Common Waveform Measurements at the Touch of a Button

Keystroke Programming

GPIB Interface

7854



The 7854 complies with IEEE Standard 488-1978

Waveform Parameters at the Touch of a Key

Dc to 400 MHz Bandwidth @ 10 mV/div

Calibrated Sweep Rates to 500 ps/div

Stores Repetitive Waveforms up to 400 MHz

Single Shot Events up to 50 μ s/div (with 7B87 Time Base)

Signal Averaging

Pretrigger (with 7B87 Time Base)

Resolution up to 0.01 div on Stored Data (10 bits)

Choose 128, 256, 512, 1024 Points/Waveform

Keystroke Programming (up to 1000 lines)

GPIB Interface (Standard)

APPLICATIONS

Power Supply Testing

Fiber Optics

Total Harmonic Distortion (Audio)

The 7854 Oscilloscope represents a new approach to waveforms. It displays solutions to common measurement problems on screen at the touch of a button. Now you can concentrate on decision making instead of measurement taking. The 7854 gives you the features of a Tektronix 7000 Series high performance scope linked with advanced digital storage and waveform processing. It also offers programmable measurement routines, GPIB interface, and compatibility with 7000 Series plug-in units.

The 7854 can display real time and stored waveforms separately or simultaneously. With optional memory up to 40 waveforms can be stored and recalled for easy comparison.

Signal averaging can recover signals buried in noise and improve measurement accuracy. One or two cursors selectable for voltage and time measurements. One cursor provides measurements referenced to ground and time zero, whereas two cursors provide Δ time and Δ voltage. Cursors also bracket areas of the waveform that are to be measured with standard waveform measurement routines; i.e., min, max, p-p.

For single-shot use, the 7B87 Time Base plug-in provides pre-trigger control which allows storage of events that precede the trigger. The amount of pre-trigger data can be varied continuously.

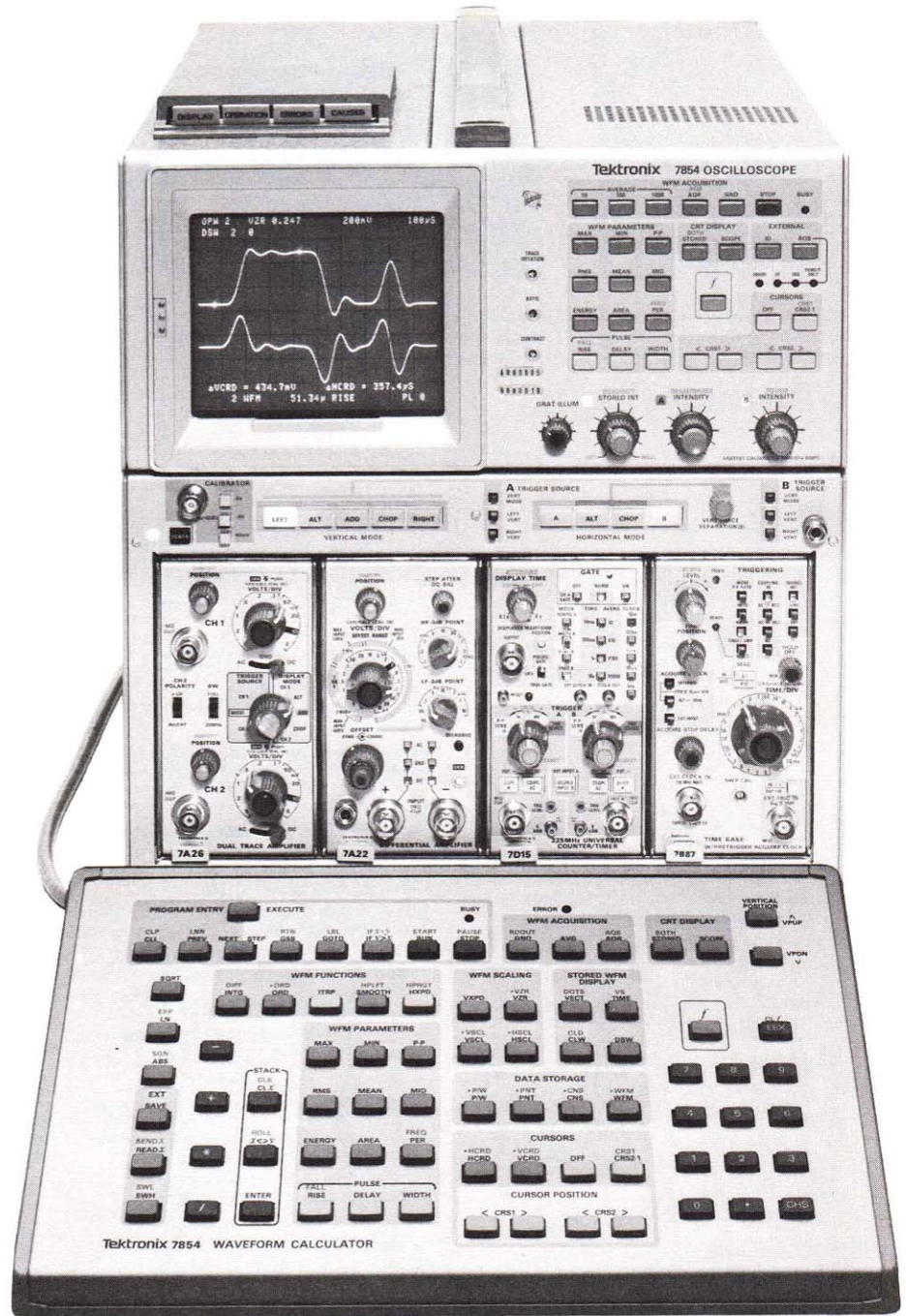

The mainframe and calculator keyboards contain a series of buttons representing the most commonly used waveform parameters. These functions operate on stored waveforms. Keystroke programming from the keyboards enable the user to design measurement routines tailored to individual tests or experiments.

7854 CHARACTERISTICS VERTICAL REAL TIME SYSTEM

Input — Two plug-in compartments; compatible with 7000 Series plug-ins.

Modes of Operation — LEFT, ALT, ADD, CHOP, RIGHT.

Mainframe Bandwidth — 400 MHz with 7A29 and 7A19 Amplifier plug-in.

Mainframe Step Response — 0.9 ns or less with 7A29 and 7A19 Amplifier plug-in.

Chopped Mode — Rep. rate is \approx 1 MHz.

Delay Line — Permits viewing leading edge of displayed waveform (7B50 Series time bases not recommended for 7854 except 7B50A).

Trace Separation Range — In dual-sweep modes, B trace can be positioned 4 divisions above or below the A trace.

CRT AND DISPLAY FEATURES

CRT Display Modes —

SCOPE (Conventional display.)

STORED (Digital data display.)

BOTH (Stored mode plus real time waveforms.)

PROGRAM ENTRY (User program text display.)

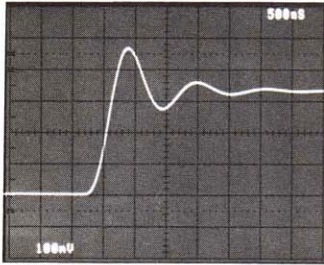

Conventional Scope: In the SCOPE mode, the 7854 provides a complete plug-in scope giving standard displays like other Tektronix high performance scopes.

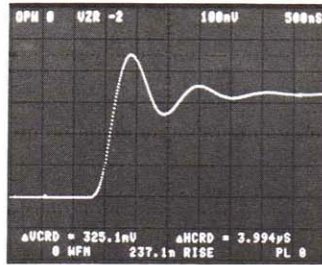

Storage Scope: Rise time is calculated by pushing a single key. Time and voltage differences between cursors are shown on the line above rise time.

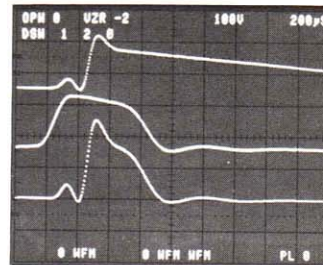

Multiple Storage and Calculation: Volts, current, and power are all shown on the display. Power ($V = .1$) is calculated with two keystrokes.

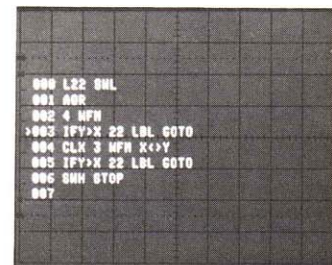

Waveform Processing: Keystroke Programming enables the user to design measurement routines tailored to individual tests or experiments.

HORIZONTAL REAL TIME SYSTEM

Input — Two plug-in compartments; compatible with 7000 Series plug-ins. 7000 Series vertical amplifiers and specialized plug-ins may also be used.*

Modes of Operation — A, ALT, CHOP, B.

Fastest Calibrated Sweep Rate — 0.5 ns/div.

Chopped Mode — Repetition rate is ≈ 200 kHz.

X-Y Mode — Phase shift between vertical and horizontal channels is within 2° from dc to 35 kHz without phase correction, (dc to 1 MHz with phase correction, B horizontal only, Option 02).

*Note: See plug-in compatibility for exceptions for digital storage.

PROGRAM STORAGE

Keystroke programming allows the mainframe to remember a sequence of keystrokes (with remote calculator keyboard or GPIB.*)

Editing — Line by line editing capability.

*Note: Vertical and Horizontal mainframe modes and all other keys except edit commands are programmable.

DIGITAL STORAGE

Equivalent Time Bandwidth — 400 MHz. See 7000 Series System bandwidth specifications.

Accuracy — Refer to Plug-in specifications.

Acquisition Channels — One or two simultaneous channels (Plug-in CHOP mode not valid).

Acquisition Window — ± 5 divisions from center screen both vertically and horizontally.

Resolution —

Vertical, 0.01 divisions.

Horizontal, selectable points/waveform on remote keyboard only.

| Horizontal Resolution (divs) | Points per waveform |
|------------------------------|---------------------|
| 0.01 | 1024 |
| 0.02 | 512 |
| 0.04 | 256 |
| 0.08 | 128 |

PLUG-IN COMPATIBILITY

Most all 7000 Series Plug-ins are compatible in the standard oscilloscope display mode. The 7L5 and 7L18 Spectrum Analyzers require factory modification for optimum use with digital storage operation. The 7D01, 7D02 and 7T11 are not compatible in STORED mode.

The 7B87 provides pretrigger for the 7854. Pretrigger allows you to view what has occurred before the trigger event in single shot applications. The amount of pre-trigger time is determined by the Acquire-Stop delay time setting. The total amount of pre-trigger is 0.2 to 9.9 times the time/div setting.

Single Shot Performance — Using 7B87 with 7854 Internal clock.

| Fastest Sweep (Time/Div) | Points per waveform |
|--------------------------|---------------------|
| 50 μ s | 128 |
| 100 μ s | 256 |
| 200 μ s | 512 |
| 500 μ s | 1024 |

OUTPUTS/INPUTS

+ **Sawtooth** — Positive-going with baseline at $0 V \pm 1 V$ into 1 M Ω . Voltage is 1 V/div ($\pm 10\%$) into 1 M Ω , 50 mV/div ($\pm 15\%$) into 50 Ω . Output R is ≈ 950 .

MEMORY FORMAT

| | STANDARD | | | | OPTION 2D | | | | OPTION 0D |
|------------------------------------|----------|-----|-----|------|-----------|-----|-----|------|-----------|
| | 128 | 256 | 512 | 1024 | 128 | 256 | 512 | 1024 | 512 |
| Points Per Waveform* | 128 | 256 | 512 | 1024 | 128 | 256 | 512 | 1024 | 512 |
| Max No of Waveforms | 16 | 8 | 4 | 2 | 40 | 20 | 10 | 5 | 1 |
| Max No of Constant Registers | 50 | | | | 100 | | | | 0 |
| Max No of Prog Commands plus lines | 920 | | | | 2000 | | | | 0 |

*Unless otherwise selected, default value is 512 at power-up.

+ **Gate** — Positive pulse of the same duration and coincident with sweep. Output voltage is 10 V ($\pm 10\%$) into 1 M Ω , 0.5 V ($\pm 10\%$) into 50 Ω . Output R is ≈ 950 Ω . Source is selectable from A gate, B gate, or DELAYED gate.

Vertical Signal Out — Selected by A TRIGGER SOURCE switch. Output voltage is 0.5 V/div into 1 M Ω , 25 mV/div into 50 Ω . Output R is ≈ 950 Ω . Bandwidth depends upon vertical plug-in.

Remote Single Sweep Reset — Rear Panel BNC, ground closure activated.

TTL Output — Rear panel BNC, TTL output under remote keyboard control (SWH and SWL).

External Z-Axis Input — 2 V p-p for full intensity range from dc to 1 MHz. Positive signal blanks the trace. Maximum input voltage is 15 V (dc plus peak ac).

Camera Power Output — Three-prong connector to the left of the CRT provides power, ground, and remote single-sweep reset access for the C-50 Series Cameras.

Memory Back-Up Power Input — 6.0 V to 6.5 V at 0.7 amp to preserve stored data if mainframe's power is interrupted.

CALIBRATOR

Voltage Output — Squarewave, positive-going from ground. Ranges are 40 mV, 0.4 V, and 4 V into 100 k Ω ; 4 mV, 40 mV, and 0.4 V into 50 Ω . Amplitude accuracy is within 1%; repetition rate is 1 kHz within 0.25%.

Current Output — 40 mA available through Calibrator output with optional BNC to current loop adapter.

POWER REQUIREMENTS

Line Voltage Ranges — 90 V-132 V, 180 V-250 V.

Line Frequency — 48-440 Hz.

Max Power Consumption — 230 W.

Included Accessories — Power cord (161-0066-00).

BNC-to-BNC Cable — (012-0203-00).

PHYSICAL CHARACTERISTICS

| Dimensions | | cm | in |
|---------------------|-------------|--------------------|------------|
| Mainframe | Height | 34.8 | 13.7 |
| | Width | 30.5 | 12.0 |
| | Length | 62.7 | 24.7 |
| Waveform Calculator | Height | 6.9 | 2.7 |
| | Width | 27.7 | 10.9 |
| | Length | 16.5 | 6.5 |
| | Cord Length | 14.2 (within 7 cm) | 5.6 |
| Weight | | kg | lbs |
| Net Weight | | 20.4 | 45 |
| Shipping | | 28.2 | 62 |

IEEE-488 INTERFACE

Standard — Conforms to IEEE-488 1978 standard.

Interface Functions Subset Implemented:

- SH1 Complete Source Handshake
- AH1 Complete Acceptor Handshake
- T5 Talker Function
- L3 Listener Function
- SR1 Complete Service Request Capability
- RL1 Complete Remote/Local Capability
- DC1 Complete Device Clear Capability
- DT1 Complete Device Trigger Capability

I/O Records — Waveforms constants, program text, and display text.

End of Message Terminator (Selectable in TALK/LISTEN mode for EOI or LF/EOI) — Compatible with Tektronix and other popular controllers.

Device Address — Selectable via rear panel switch.

Remote Operation — All keystroke functions and vertical and horizontal modes can be remotely operated via the GPIB.

ORDERING INFORMATION

(Plug-ins not included)

| | |
|---|-----------------|
| 7854 Oscilloscope (including remote calculator keyboard) | \$11,950 |
| Option 02 (X-Y Phase Correction) | Add \$150 |
| Option 03 (Emc Modification) | Add \$250 |
| Option 78 (P11 Phosphor) | Add \$35 |
| Option 0D (Delete GPIB and Remote Keyboard, one waveform storage) | Sub \$500 |
| Option 2D (4k Expanded Memory, 040-0941-00) | Add \$1000 |

INTERNATIONAL POWER CORDS & PLUG OPTIONS

| | |
|--|-----------|
| Option A1 Universal Euro 220 V/16A | No Charge |
| Option A2 UK 240 V/13A | No charge |
| Option A3 Australian 240 V/10A | No Charge |
| Option A4 North American 240 V/15A | No Charge |

7B87 Time Base required only for pretrigger and single shot digitizing . \$1480

The 7854 is also available as a WP1310 Signal Processing System. This system is a synergistic combination of the TEKTRONIX 7854 Oscilloscope and 4052 Graphic Computer. Together, these two instruments automate the entire waveform test and measurement process, from acquisition and calculation to storage and display formatting.

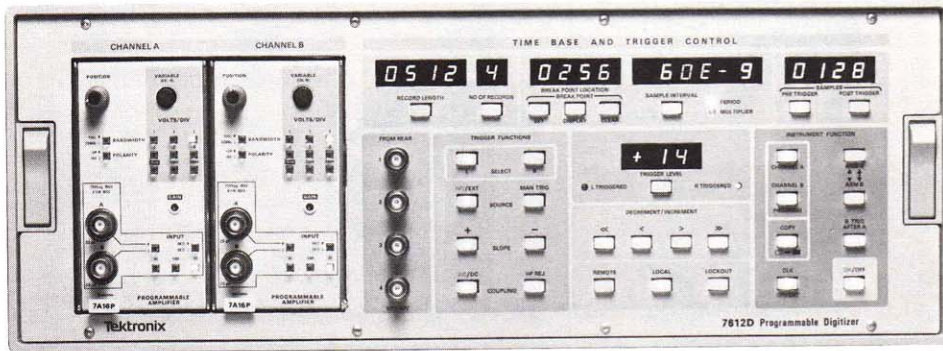

7612D

GPIB
IEEE-488

The 7612D complies with IEEE Standard 488-1975, and with Tektronix Codes and Formats Standard.

200 MHz Maximum Sampling Rate

Two Channels, Two Time Bases

8 Bit Resolution

2048 Words of Memory per Channel

5 ns to 1 s Selectable Sampling Intervals with Interval Switching Allowed During Waveform Acquisition

Pretrigger and Posttrigger Operation

Fully Programmable over IEEE-488 Bus For System Oriented Operation

APPLICATIONS

Automated Testing

EMP

Non-Destructive Testing

The 7612D Programmable Digitizer is a dual-channel, dual time base waveform digitizer for use under computer control. It has a maximum sampling rate of 200 MHz. Each channel has its own analog-to-digital converter, a new type designed by Tektronix for accurate, high-speed waveform digitizing. Each channel also has its own time base operating from a single 200 MHz crystal-controlled clock. The result...two fully independent channels capable of capturing one waveform each, simultaneously, with the same or different vertical sensitivities and time-base settings.

And there's still more flexibility available. The number of samples per waveform (record length) can be selected, from 256 to 2048. The sample rate can be changed during waveform digitizing, for example, using dense sampling on fast transitions and switching to sparser sampling for slow

decays. Also, each channel's local memory can be partitioned into one to eight equal-length records. You have the choice, too, of looking at waveforms before the triggering event (pretrigger), immediately after the trigger, or delayed from the trigger (posttrigger). Or you can choose to operate the channels dependently by triggering one after the other.

All 7612D functions can be selected manually or operated under program control over the IEEE-488 bus. Add two 7A16P Programmable Amplifier plug-ins, one for each channel, and you have program control over every waveform acquisition function.

Extracting information from medium-speed signals is a typical application of 7612D systems.

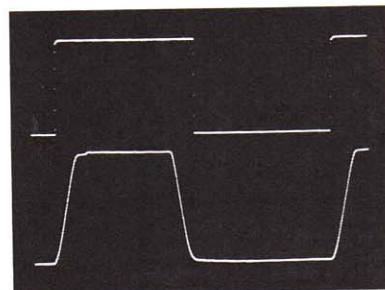

figure 1. The complete period of a signal (top trace) is recorded at 200 ns; by changing the sample rate to 10 ns during rise and fall times and 800 ns during the plateau (bottom trace), you can measure rise time, fall time, pulse width and interval accurately on a single shot signal.

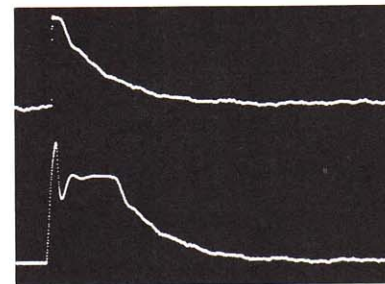

figure 2. A decaying signal recorded at a 10 μs sampling rate (top trace); the same signal can be recorded at a 100 ns sampling rate during the initial portion and switched back to a 10 μs sampling rate (bottom trace), to capture all information on a single shot signal.

SYSTEMS

The 7612D is also available in WP3000 Series Signal Processing Systems. These fully automatic systems are designed, assembled, tested, and documented to satisfy the demand for speed, automation, accuracy, and repeatability in characterizing devices or phenomena which give rise to waveforms in the second to submicrosecond range. For more information on these systems, contact your local Tektronix Sales Engineer.

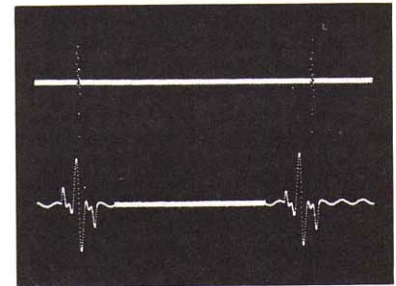

figure 3. A signal with two echoes recorded at a uniform sampling rate (top trace), the same signal recorded at an increased sampling rate during each echo (bottom trace), to capture each echo with increased resolution.

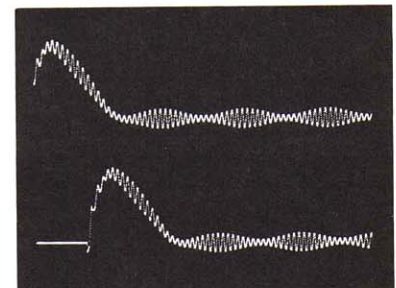

figure 4. A transient response of a system at power-up recorded with no pre-trigger (top trace); by using the pre-trigger the complete response can be digitized (bottom trace).

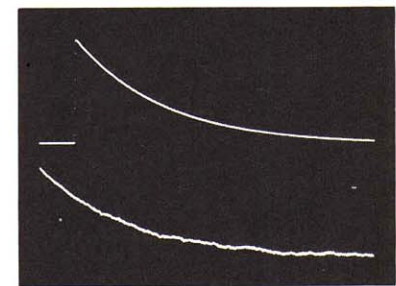

figure 5. The initial portion of an exponential decay is recorded on Channel A (top trace); Channel B, set at a higher sensitivity and triggered to record after Channel A has finished, captures the remaining pulse tail with increased vertical resolution (bottom trace).

7612D CHARACTERISTICS

VERTICAL SYSTEM

Channels — Two left-hand plug-in compartments compatible with all 7000 Series amplifier plug-ins. Fully programmable when 7A16P Plug-ins are used.

Bandwidth — 80 MHz with 7A16P Plug-in.

Modes of Operation — Left channel with Time Base A and right channel with Time Base B.

TIME BASES A AND B

Type — Two built-in digital time bases with a common crystal-controlled clock.

Clock — Internal: 200 MHz $\pm 0.0035\%$; stability: within 10 ppm/year. External: from signal source ≤ 200 MHz.

Sample Interval — With internal clock: selectable from 5 ns to 1 s in a 1, 2, 3...9 sequence (excluding 6, 7, 8 and 9 ns). With external clock: Selectable from 1 to 200 x 10⁶ times the external clock period in a 1, 2, 4, 6...20 sequence.

Interval Switching — Sample interval can be changed up to 13 times per waveform record with preservation of time relationships.

TIME MEASUREMENT ACCURACY

Without sample interval switching: 0.0035% (stability 10 ppm/year). With sample interval switching: 0.0035% (stability 10 ppm/year) for all sample intervals slower than 5 ns.

Modes of Operation — Time Base A with left channel and Time Base B with right channel. Independent or B triggerable after A completes its acquisition.

TRIGGERING A AND B

Source — Left or right plug-in, external, manual by push button.

Mode — Single sweep.

Coupling — Ac, dc, ac Hf REJ, dc Hf REJ.

Slope — Positive or negative.

Level Range — Internal: at least ± 128 LSB in 256 steps. External: at least ± 1.28 V in 256 steps.

Trigger Jitter (Internal) — 0.1 ns or less, dc to 100 MHz.

Triggering Error — ± 1 sample ambiguity in recognizing the trigger, 1 sample maximum recognition error between channels (using same trigger channel for both time bases).

Trigger Sensitivity —

| Coupling | Triggering Frequency Range | Minimum Signal Required | |
|-----------|----------------------------|-------------------------|--------|
| | | Internal | Ext |
| Ac | 40 Hz to 50 MHz | 20 LSB | 100 mV |
| | 50 MHz to 100 MHz | 44 LSB | 100 mV |
| Ac Hf REJ | 40 Hz to 50 kHz | 20 LSB | 100 mV |
| Dc | dc to 50 MHz | 20 LSB | 100 mV |
| | 50 MHz to 100 MHz | 44 LSB | 100 mV |
| Dc Hf REJ | dc to 50 kHz | 20 LSB | 100 mV |

ARMING A AND B

Push button or computer control.

DIGITIZING AND STORAGE

Method — Continuous, sequential digitizing of the input signals with storage of samples selected by instrument settings.

Resolution — 8 bits.

Dynamic Accuracy — Signal to noise ratio performance at 25°C for a half scale sinewave input signal (an ideal 8 bit digitizer would give a S/N ratio of 43.8 dB).

| Signal Freq. | S/N Ratio |
|--------------|-----------|
| 300 kHz | 42.0 |
| 20 MHz | 32.0 |
| 80 MHz | 20.0 |

Internal Memory — Type: ECL. Size: 2048 8-bit words per channel, total of 4096 8-bit words.

Record Length, A or B — 256, 512, 1024, or 2048 samples. Number of stored records: Up to eight 256-word, four 512-word, two 1024-word, or one 2048-word records per channel, each requires a trigger. Trigger is automatically rearmed after each record acquisition.

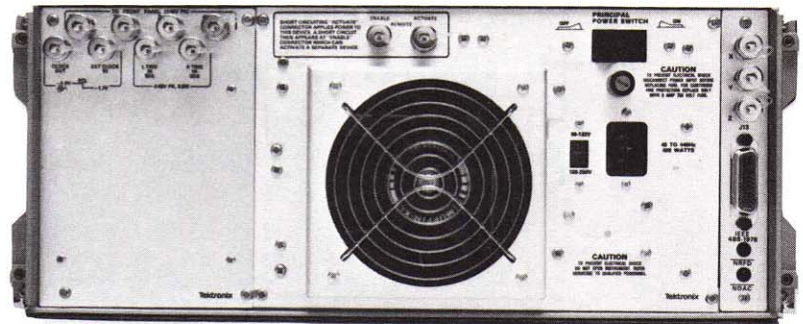

7612D rear panel: the GPIB connector and outputs for an X-Y-Z monitor (right); clock input/output, trigger inputs, and BNC connectors to feed signals to the front panel (left); remote power ON/OFF is also provided through the two central BNC connectors.

Pretrigger Delay Range — Selectable in multiples of 8 samples. Without sample interval switching: from 0 up to 16 samples less than the record length. With sample interval switching: from 0 up to 16 samples less than the position of the first sample interval change.

Posttrigger Delay Range — Selectable in multiples of 8 samples from 8 to the record length (requires selection of only one record).

OUTPUTS/INPUTS

X, Y, Z Analog Output — Provides for analog display of data in memory. X and Y level is 1 V p-p into 100 k Ω or greater; adjustable from 0.75 V to 1.3 V.

Z level is 0 to 1 V (full white) into 100 k Ω or greater.

Clock Out — Provides internal clock signal at ECL level.

External Clock In — ECL levels. ≤ 1 ns rise and fall time. 2.5 ns minimum pulse width and ≤ 200 MHz.

L and R Trig In — Provide external trigger input to the left and right trigger channels (50 Ω terminated).

1, 2, 3, 4 — Four feed-through connections to the front panel.

Digital Interface — Conforms to IEEE Standard 488-1978.

IEEE-488 INTERFACE

Standard — Conforms to IEEE-488 1975 Standard.

Interface Functions Subset Implemented:

- SH1 Complete source handshake.
- AH1 Complete acceptor handshake.
- TE6 Extended talker function.
- LE4 Extended listener function.
- SR1 Complete service request capability.
- RL1 Complete remote/local function.
- PP $\cancel{\text{P}}$ No parallel poll.
- DC1 Complete device clear capability.
- C $\cancel{\text{C}}$ No controller function.
- DT $\cancel{\text{D}}$ No device

Response to Interface Control Messages — The 7612D responds to the following interface control messages:

- GTL — Go to local.
- LLO — Local lockout.
- SDC-DCL — Selected device clear and device clear.
- SPE-SPD — Serial poll enable and disable.
- IFC — Interface clear.

IEEE-488 Bus Addresses — Mainframe and programmable plug-ins share a common primary address and are differentiated through the use of secondary addresses.

Programmable Functions — All instrument settings and operating modes are programmable.

Format — Commands in ASCII, waveform data in binary (range 0 to 377₈).

Transfer Rate — 710 k bytes/second maximum.

Waveform Transfer Time — To an infinitely fast controller: 8.35 ms for one 2048 points record. Actual transfer time depends on controller and software speed.

ENVIRONMENTAL

Temperature Range — Operating: 0-40°C. Nonoperating: -62°C to +85°C.

Altitude — Operating: -250 to +15,000 ft (-76 to +4570 meters). Nonoperating: -250 to +50,000 ft (-76 to +15,200 meters).

POWER REQUIREMENTS

Line Voltage Range — 90 V to 132 V ac and 180 V to 250 V ac.

Line Frequency — 48 to 440 Hz.

Power Consumption (including plug-ins) — Maximum 400 watts, 5 A at 115 V 60 Hz.

Remote Control — Remote power ON/OFF capability is provided.

PHYSICAL CHARACTERISTICS

Size — Fits 19 in rack. Height: 178 mm, (7 in). Width: 483 mm, (19 in). Length: 703 mm, (27.70 in).

Weight — 25 kg, (55 lb).

STANDARD ACCESSORIES

Operators and Service Manuals, set of rack slides, power cord, IEEE-488 bus cable.

Order 7612D Programmable Digitizer \$26,400 (Plug-ins not included)

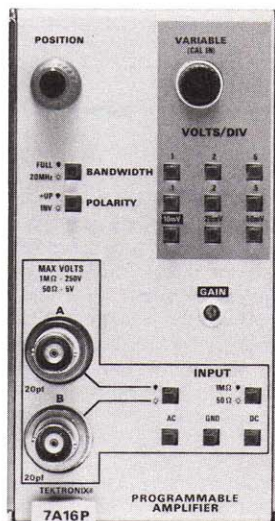

The 7A16P is a fully programmable vertical amplifier used in the 7612D. For further information, see plug-in specifications in the 7000 Series Plug-in section pages 183-204.

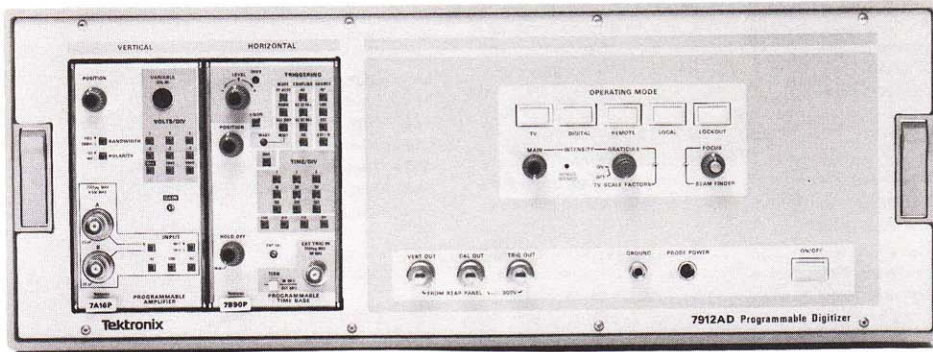

SYSTEMS

The 7912AD is also available in WP2000 Series Signal Processing Systems. These fully automatic systems are designed, assembled, tested, and documented to satisfy the demand for speed, automation, accuracy, and repeatability in characterizing devices or phenomena which give rise to waveforms in the millisecond to nanosecond range. For more information on these systems contact your local Tektronix Sales Engineer.

7912AD



The 7912AD complies with IEEE Standard 488-1975, and with Tektronix Codes and Formats Standard.

Digitize and Store Single-Shot or Repetitive Signals from Millisecond to Subnanosecond duration

500 MHz Bandwidth at 10 mV/div

500 ps/div Fastest Calibrated Sweep Rate

Waveform Digitizing to 9-Bit Vertical and 9-Bit Horizontal Resolution

Built-In Signal Averaging Capability

Fully Programmable over IEEE-488 Bus For System Oriented Operation

APPLICATIONS

Destructive Testing

Laser Research

Automated Testing

Capturing high-speed waveforms is the 7912AD's forte. Each waveform can be sampled up to 512 times within selectable time window ranging from ten milliseconds to five nanoseconds (50 kHz to 100 GHz equivalent sampling rate).

This performance is accomplished by a Tektronix scan converter which writes the signal onto a silicon-diode target array. In TV Mode, the signal information is read from the target and converted to composite video for a bright display on a television monitor. However, in the Digital Mode the waveform data is read into an internal memory. From this memory, the digitized waveform can be transferred via the IEEE-488 bus to an external controller for processing.

The 7912AD Mainframe is programmable over the same IEEE-488 bus. When the programmable plug-ins (one 7A16P Programmable Amplifier and one 7B90P Programmable Time Base) are used, the 7912AD becomes a fully programmable digitizer with a bandwidth of 200 MHz. This is a significant step toward fully automated test and measurement in disciplines such as laser and energy-related research, component or subassembly testing, and other areas requiring information extraction from high-speed waveforms.

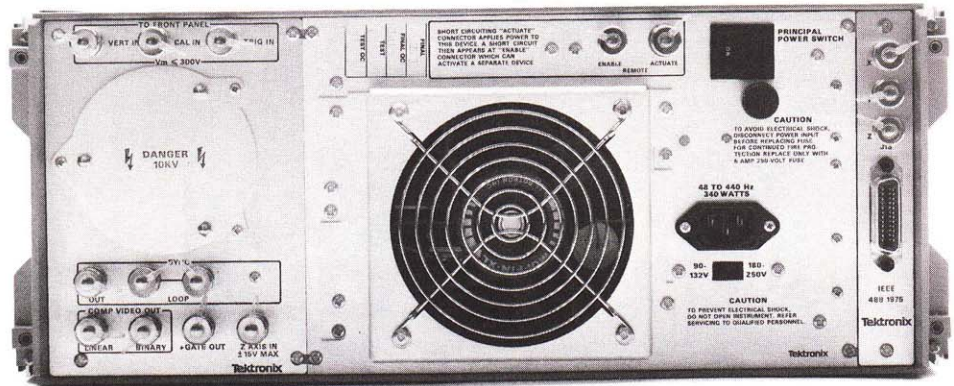

VERTICAL SYSTEM

Channels — Single plug-in compartment accepts any 7000 Series amplifier plug-in. Fully programmable when 7A16P is used.

Bandwidth — Determined by amplifier plug-in. 7A16P: 200 MHz. 7A19: 500 MHz.

Delay Line — Permits viewing of leading edge of acquired waveform.

HORIZONTAL SYSTEM

Channels — Single plug-in compartment accepts any 7000 Series time base. Fully programmable with 7B90P.

Fastest Calibrated Sweep Rate — 500 ps/div with the 7B90P or 7B92A Time Bases.

Slowest Recommended Sweep Rate — 1 ms/div in digital mode, possible loss of data below this limit.

DIGITIZING AND STORAGE

Method — Scan conversion.

Resolution — 9 bits. In the Digital Mode, the target is scanned in a 512 x 512 point matrix offering at least 400 discrete horizontal elements, each with a range of at least 320 discrete vertical values. In the TV Mode, the target is scanned in a standard TV format with a resolution of at least 400 lines at 50% response.

Writing Rate (+10°C to +40°C) — TV Mode: writes an 8-div sinewave of at least 500 MHz in a single sweep. Digital Mode: stores a single 8-div pulse with a rise time of 1 ns or less. Option 04, increases TV Mode writing rate by factor of 2 and Digital Mode writing rate by 2.5.

Target Defects — No more than six points digitized other than those written by input waveform. Built-in firmware allows for defect removal by an external controller.

Memory — Type: semiconductor. Size: 4096 10-bit words for data from target and two 512 16-bit word areas for internally processed and reduced data. Record Length: 512 samples per waveform maximum.

ELECTRONIC GRATICULE

8 x 10 division dot matrix written onto the scan converter target immediately after waveform acquisition. Can be displayed simultaneously with the input signal on the TV monitor or digitized and stored.

OUTPUTS/INPUTS

X, Y, Z Analog Output — Provides for analog display of data in memory. X and Y level is 1 V p-p into 100 kΩ or greater; adjustable from 0.75 V to 1.3 V. Z level is 0 to 1 V (full white) into kΩ or greater.

Composite Video Output — Only available in TV mode. Used to drive a TV monitor for displaying signal written on scan-converter target as an aid to setting intensity for complete digitizing. Linear Output: Replica of the signal read from the target with sync added. Binary Output: Two-level output derived from the linear composite video output. Used to indicate on the TV monitor how well a waveform will be digitized. Scale factor readout included in both linear and binary.

Sync Output — At least 4 V into 75 Ω. Conforms to EIA RS-170.

Sync Loop — Allows TV Mode to be synchronized with external EIA RS-170 sync waveform.

+Gate Output — Provides a positive pulse with a duration equal to and coincident with the time-base sweep.

Z-Axis Input — ±1 V input modulates the writing gun intensity over its full range.

Vert In, Cal In, Trig In — Three internal 50 Ω coaxial cables connect signals from the rear panel to the front panel to ease system configuration in rackmounts.

Probe Power — Provides power for Tektronix active probes.

IEEE-488 INTERFACE

Standard — Conforms to IEEE-488 1978 Standard.

Interface Functions Subset Implemented:

- SH1** Complete source handshake.
- AH1** Complete acceptor handshake.
- TE6** Extended talker function.
- LE4** Extended listener function.
- SR1** Complete service request capability.
- RL1** Complete remote/local function.
- PP 0** No parallel poll.
- DC1** Complete device clear capability.
- C 0** No controller function.
- DT1** Device trigger complete.

ENVIRONMENTAL

Temperature Range — Operating: 0-40°C. Nonoperating: -55°C to +75°C.

Altitude — Operating: up to 4570 m (7000 ft). Nonoperating: Up to 15,200 m (50,000 ft).

Emc (plug-ins inserted) — Meets MIL-STD-461A and 462 radiated and conducted interference from 30 Hz to 1 GHz.

POWER REQUIREMENTS

Line Voltage Range — 90 V to 132 V ac and 180 V to 250 V ac.

Line Frequency — 48-440 Hz.

Power Consumption (including plug-ins) — 360 watts maximum.

Remote Control — Remote power ON/OFF capabilities provided.

PHYSICAL CHARACTERISTICS

Size — Fits 19 inch rack. Height: 177 mm (7 in). Width: 483 mm (19 in). Length: 679 mm (26.8 in).

Weight — 24.7 kg (54.6 lb).

STANDARD ACCESSORIES

Power cord, set of rack slides, IEEE-488 bus cable, Operator and Service manuals.

7A16P

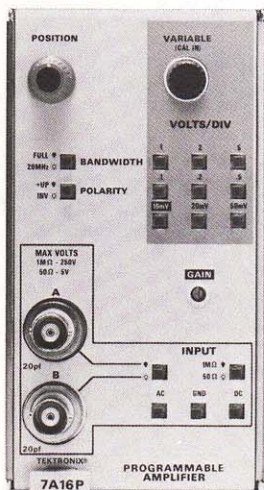

Programmable Amplifier

7B90P

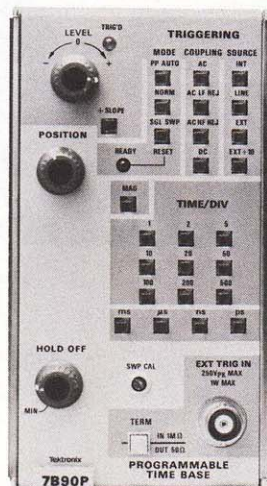

Programmable Time Base

ORDERING INFORMATION
(Plug-ins not included)

It is recommended that 7912ADs not be purchased or operated without an accompanying TEKTRONIX 634 Raster Scan Display Monitor with Option 11 (see p. 96).

7912AD Programmable Digitizer \$24,800

OPTIONS

Option 04 Change to Fast Digitize (changes scanning matrix to 526 x 256 points, changes electronic graticule to mark only every other division, increases writing rate No Charge

Option 09 Change Line Voltage (220 V/50 Hz) No Charge

Option 13 Change TV scan to 625 lines at 50 Hz No Charge

Option 30 Delete IEEE bus cable Sub \$90

634 Option 11 Raster Scan Display Monitor \$2940

Tektronix offers maintenance training classes on the 7912AD Programmable Digitizer. For further training information, contact your local Sales Office or request a copy of the Tektronix Customer Training Catalog on the return card.

7000 SERIES PLUG-INS

CONTENTS

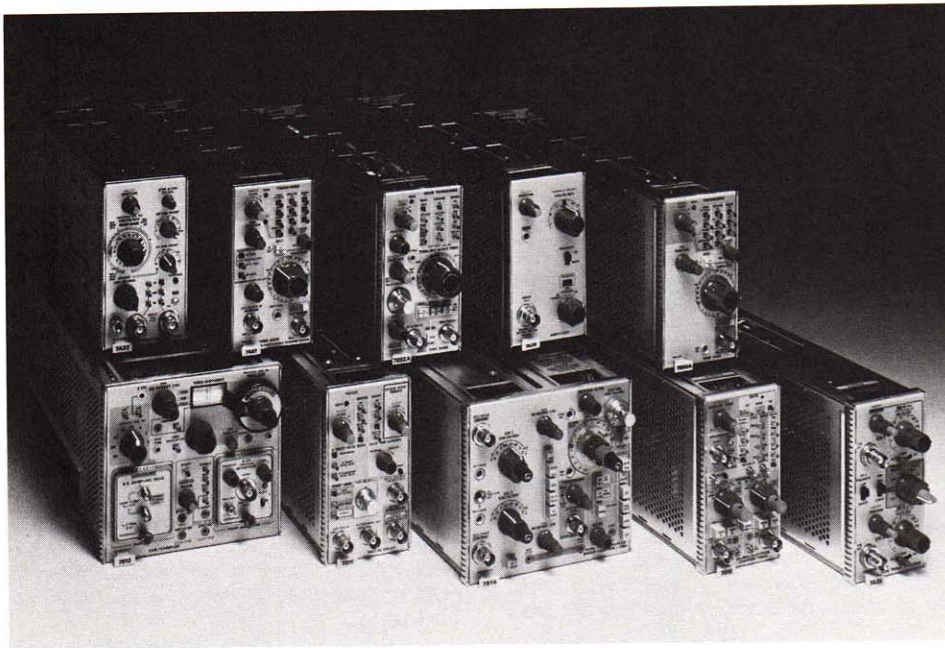

For the 7000 Series you can select from over thirty-five different plug-ins. For example, digital multimeters, counters and A-D converters. With this plug-in selection you can solve problems in many applications including spectrum analysis, curve tracing, logic analysis, and sampling. This variety lets you tailor your instrument to meet your immediate need. And to expand its capabilities later as your needs change.

| | |
|--|-----|
| Dc to 225 MHz Amplifiers | 184 |
| Differential Amplifiers | 186 |
| FET Probe Amplifier | 187 |
| Amplifiers | 188 |
| Programmable and Digital Pretrigger Time Base | 189 |
| Delayed and Δ Delaying Time Base | 190 |
| Dual Time Bases | 192 |
| Single Time Base | 194 |
| Digital Delay | 195 |
| Universal Counter/Timer | 196 |
| A/D Converter | 198 |
| Digital Multimeter | 198 |
| Sampling Units to 14 GHz | 199 |
| 45 ps TDR or General Purpose Sampler | 200 |
| 1 GHz Dual Trace, Delayed Sweep Sampler | 201 |
| Sampling Heads to 14 GHz | 202 |
| Trigger Countdown Head | 203 |
| Trigger Recognizer Heads | 203 |
| Pulse Generator Heads | 203 |
| Curve Tracer | 204 |
| Readout Unit | 204 |

7000 Series Plug-ins

Single Trace Amplifiers

Differential Amplifiers

Dual Trace Amplifiers

Delayed and Δ Delaying Time Base

Dual Time Bases

Curve Tracer

Digital Delay

A/D Converter

Digital Multimeter

Universal Counter/Timer

Sampling

TDR

7A15A

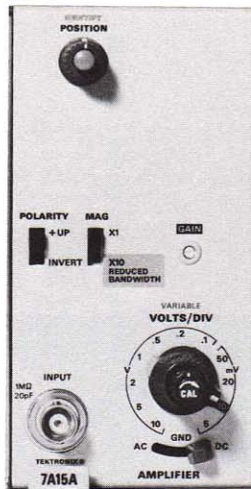

Dc to 80 MHz Amplifier

7A15A

Dc to 80 MHz Bandwidth (7900 Family)

**5 mV/div to 10 V/div
Calibrated Deflection Factors**

500 μ V/div at 10 MHz (X10 Gain)

1 M Ω Input

The 7A15A is an easy to use, 80 MHz amplifier that features a X10 magnifier to increase the sensitivity to 500 μ V/div with 10 MHz bandwidth. It has a constant bandwidth at all deflection factors in the X1 setting. Polarity of the display is selectable.

Deflection Factor — 5 mV/div to 10 V/div in 11 calibrated steps (1-2-5 sequence). X1 gain accuracy is within 2% with X1 gain adjusted at 10 mV/div. X10 gain (increases sensitivity to 500 μ V) accuracy is within 10% at 10 MHz bandwidth throughout deflection factor settings. Uncalibrated VARIABLE is continuous between steps to at least 25 V/div.

Input R and C — 1 M Ω within 2%; \approx 20 pF.

Max Input Voltage — Dc-coupled: 250 V (dc + peak ac), ac component 500 V p-p max, 1 kHz or less. Ac-coupled: 500 V (dc + peak ac), ac component 500 V p-p max, 1 kHz or less.

Order 7A15A Amplifier \$565

7A16A



Dc to 225 MHz Amplifier

7A16A

Dc to 225 MHz Bandwidth (7900 Family)

**5 mV/div to 5 V/div
Calibrated Deflection Factors**

1 M Ω Input

The 7A16A is an easy to use, 225 MHz amplifier. It features constant bandwidth over the deflection factor range of 5 mV/div to 5 V/div. Polarity of the display is selectable; bandwidth is selectable to FULL or limited to 20 MHz for low-frequency applications.

Deflection Factor — 5 mV/div to 5 V/div in 10 calibrated steps (1-2-5 sequence). Accuracy is within 2% with gain adjusted at 10 mV/div. Uncalibrated VARIABLE is continuous between steps to a least 12.5 V/div.

Input R and C — 1 M Ω within 2%; \approx 20 pF.

Max Input Voltage — Dc-coupled: 250 V (dc + peak ac), ac component 500 V p-p max, 1 kHz or less. Ac-coupled: 500 V (dc + peak ac); ac component 500 V p-p max, 1 kHz or less.

Dc Stability — Drift with ambient temperature (constant line voltage) is 0.01 div/ $^{\circ}$ C. Drift with time (ambient temperature and line voltage constant) is 0.02 div in any one minute after 1 hour warm-up.

Order 7A16A Amplifier \$1030

Tektronix offers maintenance training classes on 7000 Series plug-ins and mainframes and new multi-media training packages on Digital Counter and Meter Concepts and Sampling Concepts. For further training information, contact your local Sales Office or request a copy of the Tektronix Customer Training Catalog on the return card.

7A16P

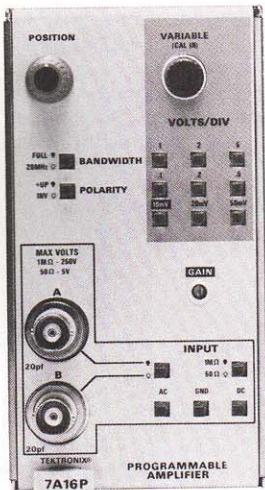

Programmable—Dc to 225 MHz Amplifier

7A16P

Fully Programmable Plug-in for 7912AD or 7612D Digitizers only

10 mV/div to 5 V/div Calibrated Deflection Factors

200 MHz Bandwidth (7900 Family)

50 Ω or 1 MΩ Input Selectable

The 7A16P is designed for use only in Tektronix 7000 Series Programmable Digitizers. All of the normal operational features of a high-quality, wide-band 7000 Series plug-in amplifier are provided in the 7A16P. These are available at the front panel for manual selection, or they can be set under program control via a programmable mainframe and the IEEE-488 bus. Whether operated manually or under program control, the front-panel push buttons light to indicate plug-in status. Plug-in status can also be read over the IEEE-488 bus by an external controller for input to instrument set-up and control routines.

Two switch selected input connectors are also provided for selecting input signal source.

CHARACTERISTICS

Bandwidth — 225 MHz, plug-in only. 200 MHz in the 7912AD. Bandwidth may be limited to 20 MHz ± 3 MHz by bandwidth limit switch.

Ac Coupled Lower Bandwidth — 10 Hz or less.

Step Response — 50 Ω input plug-in only, 1.8 ns rise time.

Deflection Factor — 10 mV/div to 5 V/div, 9 steps in a 1-2-5 sequence. Accuracy is ±2% of indicated deflection factor with GAIN adjusted at 10 mV/div.

Uncalibrated VARIABLE is continuous between steps and extends selected deflection factor to at least 2.5 times the calibrated value.

Input R and C — Selectable: 1 MΩ within 2% and ≈20 pF or 50 Ω ± 1 Ω with VSWR ≤ 1.5:1 at 200 MHz or less.

Inputs — Selectable A or B signal input connectors.

Max Input Voltage — 1 MΩ, dc coupled: 250 V (dc + peak ac), ac component 500 V p-p max, 1 kHz or less. MΩ, ac coupled: 500 V (dc + peak ac), ac component 500 V p-p max, 1 kHz or less. 50 Ω: 0.5 watts max.

Programmable Functions — All functions except VARIABLE, GAIN, and IDENTIFY are programmable.

Order 7A16P Programmable Amplifier \$2200

7A18



Dc to 75 MHz Dual Trace Amplifier

7A18

Dc to 75 MHz Bandwidth

5 mV/div to 5 V/div Calibrated Deflection Factors

1 MΩ Input

The 7A18, the basic building block of 3- and 4-trace operation, is a dual-trace plug-in amplifier. The 7A18 features constant bandwidth for all deflection factors, 5 operating modes (Ch 1, Ch 2, ALT, CHOP, ADD), trigger source selectivity and color-keyed control grouping. The 7A18 has a trace identify function. Polarity of channel 2 is selectable.

Deflection Factor — 5 mV/div to 5 V/div in 10 calibrated steps (1-2-5 sequence). Accuracy is within 2% with gain adjusted to 10 mV/div. Uncalibrated VARIABLE is continuous between steps to at least 12.5 V/div.

Input R and C — 1 MΩ within 2%; ≈20 pF.

Max Input Voltage — Dc-coupled: 250 V (dc + peak ac); ac component 500 V p-p max, 1 kHz or less. Ac-coupled: 500 V (dc + peak ac); ac component 500 V p-p max, 1 kHz or less.

Dc Stability — Drift with ambient temperature (constant line voltage) is 0.01 div/°C. Drift with time (ambient temperature and line voltage constant) is 0.02 div in any one minute after 1 hour warm-up.

Common-Mode Rejection Ratio (ADD, Ch 2 Invert) — At least 10:1, dc to 50 MHz.

Order 7A18 Amplifier \$1145

DC OFFSET OPTION

Dc Offset is for the user who needs to analyze small signals that are riding on larger signals, such as power supply ripple.

Option 06, Dc Offset — Two separate Channel 1 and Channel 2 variable offset controls are concentric with the position controls replacing the identify push-buttons of the standard 7A18. The ac-dc-ground switch of each channel is expanded to accommodate a fourth position for dc offset.

Offset Range Display — ±200 div max, equivalent to ±1 V at 5 mV/div.

Accuracy — When in DC OFFSET the deflection accuracy is derated by 1%.

Order Option 06 Dc Offset Add \$200

For recommended probes—refer to page 152.

7A26



Dc to 200 MHz Dual Trace Amplifier

7A26

Dc to 200 MHz Bandwidth (7900 Family)

5 mV/div to 5 V/div Calibrated Deflection Factors

1 MΩ Input

The 7A26, a dual-trace plug-in amplifier, is a basic building block for 3- or 4-trace operation. It features constant bandwidth for all deflection factors, 5 operating modes (Ch 1, Ch 2, ALT, CHOP, ADD), trigger source selection (Ch 1, Ch 2, MODE), and color-keyed control groupings. Polarity of channel 2 is selectable. Bandwidth may be set at FULL or limited to 20 MHz for low-frequency applications.

Deflection Factor — 5 mV/div to 5 V/div in 10 calibrated steps (1-2-5 sequence). Accuracy is within 2% with gain adjusted at 10 mV/div. Uncalibrated VARIABLE is continuous between steps to at least 12.5 V/div.

Input R and C — 1 MΩ within 2%; ≈20 pF.

Max Input Voltage — Dc-coupled: 250 V (dc + peak ac); ac component 500 V p-p max, 1 kHz or less. Ac-coupled: 500 V (dc + peak ac); ac component 500 V p-p max, 1 kHz or less.

Common-Mode Rejection Ratio (ADD, Ch 1 Invert) — At least 10:1, dc to 50 MHz.

Dc Stability — Drift with ambient temperature (constant line voltage) is 0.02 div/°C. Drift with time (ambient temperature and line voltage constant) is 0.02 div in any one minute after 1 hour warm-up.

Order 7A26 Amplifier \$1850

7A17

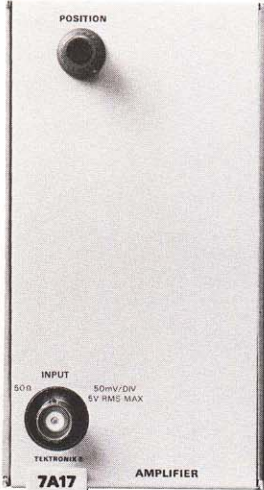

Dc to 150 MHz Bandwidth

7A17

Low Cost

Dc to 150 MHz Bandwidth (7900 Family)

50 mV/div Calibrated Deflection Factor

Easy to Customize

The 7A17 is a unique wideband, plug-in amplifier electrically and mechanically suitable for do-it-yourself design and modification.

The layout of the circuit board assembly provides a blank soldering pad matrix and ground plane surface totaling approximately 40 square inches. Circuits may be installed here. Mainframe power is identified and available on the circuit board. The front sub-panel is prepunched with holes of various sizes and shapes which allow for the mounting of connectors, switches, indicators, etc.

Deflection Factor — Adjustable to 50 mV/div. There is no step attenuation.

Input Z — 50 Ω

Max Input Voltage — 5 V RMS.

Order 7A17 Amplifier \$375

7A13

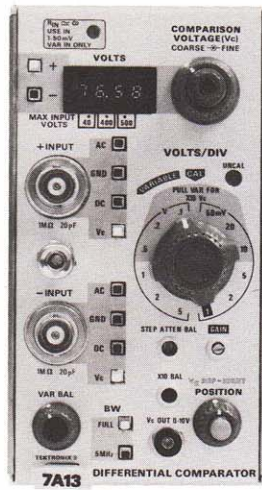

Differential Comparator Amplifier

7A13

Dc to 105 MHz Bandwidth (7900 Family)

**1 mV/div to 5 V/div
Calibrated Deflection Factors**

20,000: 1 Cmrr

10,000 cm Effective Screen Height

1 M Ω Input

The 7A13 is a differential comparator amplifier. It incorporates a number of features which make it particularly versatile, especially in multitrace combination with other 7000 Series vertical plug-ins.

The 7A13 has constant bandwidth over the 1 mV/div to 5 V/div deflection factor range. The bandwidth is selectable to FULL or 5 MHz for best displayed noise conditions for low-frequency applications.

As a differential amplifier the 7A13 provides a balanced (+ and -) input for applications requiring rejection of a common-mode signal. The cmrr is 20,000:1 from dc to 100 kHz, derating to 200:1 at 20 MHz. The unit can reject up to 10 V of common-mode signal at a deflection factor setting of 1 mV/div, increasing to 100 V rejection potential at 10 mV/div (X10 Vc pulled) and 500 V at 0.1 V/div.

As a comparator amplifier the 7A13 loses its differential capability, but provides an accurate (0.1%) positive or negative internal offsetting voltage covering the common-mode signal range of the unit. A signal of up to ± 10 V may be applied to an input (+ or -) at a deflection factor setting of 1 mV/div and, with an opposing Vc (offset voltage), viewed in 10,000 segments of 1 mV. The offset voltage is also available as an output for external monitoring.

High Cmrr Probes for Differential Amplifiers

We recommend the P6055 high cmrr adjustable 10X probes for use with Tektronix differential amplifiers.

When used in pairs, these probes increase the differential input impedance to 20 m Ω and allow adjustment for maximum common-mode rejection ratio (cmrr).

See page 336 for P6055 characteristics.

Input R and C — 1 M Ω within 0.15%; ≈ 20 pF. R in $\approx \infty$, is available in the 1 mV to 50 mV/div range, selectable by an internal switch.

Deflection Factor — 1 mV/div to 5 V/div in 12 calibrated steps (1-2-5 sequence). Accuracy is within 1.5% with gain adjusted at 1 mV/div. Uncalibrated VARIABLE is continuous between steps to at least 12.5 V/div.

Single Range —

| Deflection Factor Settings | 1mV to 50mV/div | 10 mV to 50 mV/div (X10 Vc out) and 0.1 V to 0.5 V/div | 0.1 V to 0.5 V/div (X10 Vc out) and 1 V to 5 V/div |
|--|-----------------|--|--|
| Common-mode Signal Range | ± 10 V | ± 100 V | ± 500 V |
| Max Dc-coupled Input (dc + Peak Ac at 1 kHz or less) | ± 40 V | ± 400 V | ± 500 V |
| Max Ac-coupled Input (dc voltage) | | ± 500 V | |

Max Input Gate Current — 0.2 nA or less from 0°C to +35°C; 2 nA or less at +85°C to +55°C.

Dc Stability — Drift with time (constant ambient temperature and line voltage): short term, 1 mV p-p or 0.1 div, or less (whichever is greater) over any 1-minute interval after 20 minute warm-up. Long term, 1 mV p-p or 0.1 div or less (whichever is greater) during any 1 hour interval after 20 minute warm-up. Drift with ambient temperature (constant line voltage), 2 mV/10°C to 0.2 div/10°C or less, whichever is greater.

Displayed Noise (Tangentially measured) — With X10 Vc in, 400 μ V (200 μ V RMS) or less at 1 mV/div; 0.2 div or less at 2 mV/div to 5 mV/div; 0.05 div or less at 10 mV/div to 5 V/div. With X10 Vc out, 0.4 div or less at 10 mV/div to 0.5 V/div.

Overdrive Recovery — 1 μ s to recover to within 2 mV and 0.1 ms to recover to within 1 mV after a pulse of ± 10 V or less at 1 mV/div only regardless of pulse duration.

Internal Comparison Voltage — Range, 0 V to ± 10 V; accuracy, $\pm 0.1\%$ of setting + 3 mV; Vc output R, ≈ 15 k Ω .

Common-Mode Rejection Ratio —

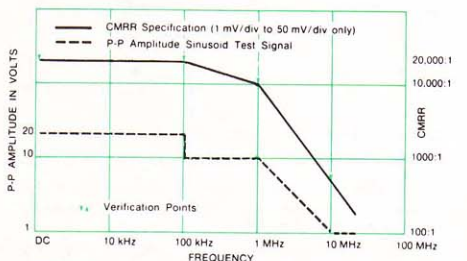

At least 2000:1, 10 mV/div to 50 mV (X10 Vc out) and 0.1 V/div to 5 V/div. Ac-coupled input at least 500:1 at 60 Hz.

Order 7A13 Amplifier \$2690

7A22



Differential Amplifier

7A22

Dc to 1 MHz Bandwidth

**10 μ V/div to 10 V/div
Calibrated Deflection Factors**

100,000:1 Cmr

Selectable Upper and Lower —3 dB Points

Dc Offset

10 μ V/Hour Dc Drift*

1 M Ω Input

The 7A22 is a differential amplifier well suited for difficult low-amplitude, low-frequency measurements.

High Cmr Probes for Differential Amplifiers

We recommend the P6055 high cmr adjustable 10X probes for use with Tektronix differential amplifiers.

When used in pairs, these probes increase the differential input impedance to 20 m Ω and allow adjustment for maximum common-mode rejection ratio (cmr).

See page 336 for P6055 characteristics.

*With constant temperature. See dc stability specifications.

Bandwidth — Hf —3 dB point; selectable in 9 steps (1-3 sequence) from 100 Hz to 1 MHz, accurate within 10% of selected frequency; rise time in 1 MHz position is 350 ns \pm 9%. Lf —3 dB point; selectable in 6 steps (1-10 sequence) from 0.1 Hz to 10 kHz, accurate within 12% of selected frequency. The switch also contains dc and ac with OFFSET positions. Ac-coupled at input, 2 Hz or less.

Deflection Factor — 10 μ V/div to 10 V/div in 19 calibrated steps (1-2-5 Sequence). Accuracy is within 2% with gain adjusted to 1 mV/div. Uncalibrated VARIABLE is continuous between steps to at least 25 V/div.

Input R and C — 1 M Ω within 1%; \approx 47 pF.

Max Input Gate Current — Differentially measured, 40 pA (+25°C) and 200 pA (+50°C) at 10 μ V/div to 10 mV/div; 10 pA (+25°C) and 20 pA (+50°C) at 20 mV/div to 10 V/div.

Single ended, one-half the differential measurement. Display shift is \pm 4 div (+25°C) and \pm 20 div (+50°C) at 10 μ V/div (ac-coupled).

Signal and Offset Range —

| | | | | |
|---|--|--------------------|------------------|--------------------|
| Deflection Factor Settings | 10 μ V to 10 mV/div | 20 mV to 0.1 V/div | 0.2 V to 1 V/div | 2 V to 10 V/div |
| Common-mode Signal Range | \pm 10 V | \pm 100 V | \pm 500 V | |
| Max Dc-coupled Input (dc + peak ac at 1 kHz or less) | \pm 15 V | \pm 200 V | \pm 500 V | |
| Max Ac-coupled Input (dc voltage) | \pm 500 V dc rejection, at least 4 x 10 ⁵ :1 | | | |
| Dc Offset Range | +1 V to -1 V | +10 V to -10 V | +100 V to -100 V | +1000 V to -1000 V |

Dc Stability — Drift with time (constant ambient temperature and line voltage): short term, 5 μ V (p-p) or 0.1 div, whichever is greater in any minute after 1 hour warm-up. Long term, 10 μ V (p-p) or 0.1 div, whichever is greater in any hour after 1 hour warm-up. Drift with ambient temperature (constant line voltage) is 50 μ V/°C or less.

Displayed Noise — 16 μ V or 0.1 div (whichever is greater) at max bandwidth; source resistance 25 Ω or less measured tangentially.

Overdrive Recovery — 10 μ s or less to recover within 0.5% of zero level after removal of a test signal applied for 1 s (signal amplitude not to exceed differential dynamic range). Front-panel OVERDRIVE light indicates that an overdrive condition is being approached.

Common-mode Rejection Ratio (for signals not exceeding common-mode signal range)

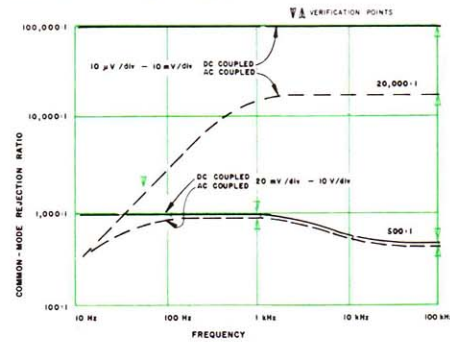

Order 7A22 Amplifier \$1410

7A11

Built-in FET Probe

Dc to 250 MHz Bandwidth (7900 Family)

5 mV/div to 20 V/div

Calibrated Deflection Factors

Dc Offset

1 M Ω Input

The 7A11 is a wideband plug-in amplifier. The captive FET probe input configuration optimizes signal acquisition with high resistance (1 M Ω) and low capacitance (5.8 pF at 5 mV/div), without loss of signal amplitude by probe attenuation. Two 20X attenuators, physically mounted in the probe

7A11



Amplifier

tip, are relay-switched into the input signal path at the appropriate deflection factor. Therefore you need not concern yourself with manual plug-in attenuators and signal dynamic range.

Deflection Factor — 5 mV/div to 20 V/div in 12 calibrated steps (1-2-5 sequence). Accuracy is within 2% of gain adjustment at 0.1 V/div. Uncalibrated VARIABLE is continuous between steps to at least 50 V/div.

Input R and C — 1 M Ω within 1%; \approx 5.8 pF (5 mV/div to 50 mV/div), \approx 3.4 pF (0.1 V/div to 1 V/div), \approx 2 pF (2 V/div to 20 V/div).

Signal and Offset Range —

| | | | |
|--|--|--|--|
| Deflection Factor Settings | 5 mV/div to 50 mV/div | 0.1 V/div to 1 V/div | 2 V/div to 20 V/div |
| Offset Range | +1 V to -1 V | +20 V to -20 V | +400 V to -400 V |
| Offset Range to Offset Out | 1:1 within 1% +0.5 mV | 20:1 within 1.5% +0.5 mV | 400:1 within 2% +0.5 mV |
| Max Dc-coupled Input | 200 V (dc + peak ac, ac component to 50 kHz) | 200 V (dc + peak ac, ac component to 40 MHz) | 200 V (dc + peak ac, ac component to 70 MHz) |
| Max Ac-coupled Input (Dc Component) | \pm 200 V | | |

Dc Stability — Drift with time (constant ambient temperature and line voltage): short term, 0.1 div or less per minute after 20 minute warm-up. Long term, 0.3 div or less per hour after 20 minute warm up. Drift with ambient temperature (constant line voltage), 200 μ V/°C or less.

Displayed Noise — 0.5 mV or 0.1 div, whichever is greater, in FULL BANDWIDTH mode, measured tangentially.

Offset Function — An internal dc source, continuously variable between +1 V and -1 V, may be used to offset the trace. (See chart for offset range.) An OFFSET OUT jack allows for monitoring of the offset voltage. OFFSET OUT source resistance is 500 Ω within 3%.

Included Accessories — Capacitor-coupler head (011-0110-00); retractable hook tip (013-0106-00); probe tip ground adapter (013-0085-00); 3 in ground lead (nose) (175-0849-00); 3 in ground lead (screw-in) (175-0848-00); 12 in ground lead (screw-in) (175-0848-02); three miniature alligator clips (344-0046-00); two insulated sleeves (166-0404-01); probe hook tip (206-0114-00); probe tip to GR 50 Ω termination (017-0088-00); 18 in cable (offset out) (175-1092-00).

Order 7A11 Amplifier \$2325

7A24

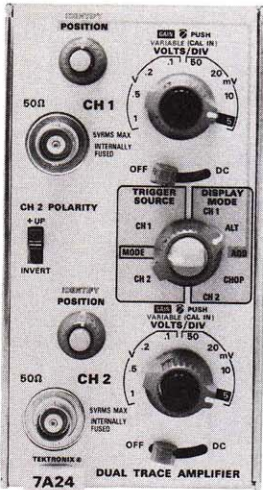

Dc to 400 MHz Dual Trace Amplifier

7A24

Dc to 400 MHz Bandwidth (with 7104)

5 mV/div to 1 V/div
Calibrated Deflection Factors

50 Ω Input

The 7A24, a high-performance, wide band, dual-trace amplifier, is designed primarily for use with the 7700, 7800, 7900, and 7100 Series Mainframes. The 7A24 offers 350 MHz bandwidth and 5 mV/div sensitivity; this provides the basic building block for 3 or 4 trace operation. It features constant bandwidth for all deflection factors, 5 operating modes (CH 1, CH 2, ALT, CHOP, ADD), trigger source selection (CH 1, CH 2, MODE), and color-keyed control groupings. Polarity of channel 2 is selectable.

Deflection Factor — 5 mV/div to 1 V/div in 8 calibrated steps (1-2-5 sequence). Accuracy is within 2% with gain adjusted to 5 mV/div. Uncalibrated VARIABLE is continuous between steps to at least 2.5 V/div.

Input R — 50 Ω within 0.5%; vswr 1.25:1 or less at 5 mV/div and 10 mV/div, 1.15:1 or less from 20 mV/div to 1 V/div at 250 MHz.

Max Input — 5 V RMS; 0.5 W max input power, internally protected.

Common-Mode Rejection Ratio — At least 10:1, dc to 50 MHz.

Dc Stability — Drift with ambient temperature (constant line voltage) is 0.02 div/°C. Drift with time (ambient temperature and line voltage constant), 0.02 div in any one minute after 1 hour warm-up.

Order 7A24 Amplifier \$2090

7A19

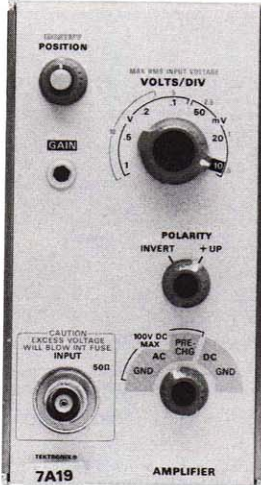

Dc to 600 MHz Amplifier

7A19

Dc to 600 MHz Bandwidth (with 7104)

10 mV/div to 1 V/div
Calibrated Deflection Factors

Optional ±500 ps Variable Delay Line

50 Ω Input

The 7A19 is a high-performance, wide band, single-trace plug-in amplifier designed primarily for use with the 7100, 7700, 7800, and 7900 Family Mainframes. The polarity of the display is selectable, either normal or inverted.

Deflection Factor — 10 mV/div to 1 V/div in 7 calibrated steps (1-2-5 sequence). Accuracy is within 3%.

Input R — 50 Ω.

Option 04, Variable Signal Delay — Permits matching the transit time of two preamps and probes to better than 50 ps. Range is ±500 ps.

Max Input — 50 div peak or 10 V RMS (2 W), whichever is less, in the dc-coupled mode. 100 V dc additional in the ac-coupled mode.

ORDERING INFORMATION

7A19 Amplifier \$1980
Option 04 Variable Sig Delay Add \$350

7A29

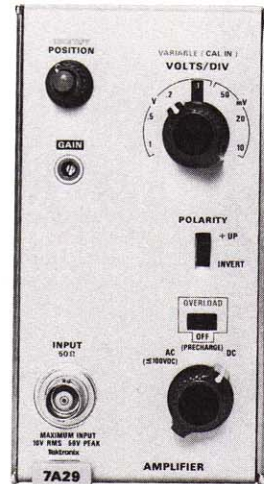

Dc to 1 GHz Amplifier

7A29

Dc to 1 GHz Bandwidth (7104)

10 mV/div to 1 V/div
Calibrated Deflection Factors

50 Ω Input

The 7A29 is a high performance, wide-bandwidth, single-trace plug-in amplifier designed primarily for use with the 7104 Mainframes. A vertical amplifier to bw of mainframe, the 7A29 has a 10 mV/div to 1 V/div vertical sensitivity.

Deflection Factor — 10 mV/div to 1 V/div in 7 calibrated steps (1-2-5 sequence). Accuracy is within 2% with gain adjusted at 0.1 V/div. Uncalibrated variable is continuous between steps to at least 2.5 V/div.

Input R — 50 Ω.

Option 04, Variable Signal Delay — Permits matching the transit time of two preamps and probes to better than 10 ps. Range is 1 ns.

Max Input — 10 V RMS or 1 W-second pulses not exceeding 50 V peak in dc coupled mode. 100 V dc additional in ac coupled mode.

Input Protection — Internal detection circuitry provides protection by automatically disconnecting excessive signals of up to 50 V. The "disconnected" condition is indicated, and has manual reset.

ORDERING INFORMATION

7A29 Amplifier \$2455
Option 04 Variable Sig Delay Add \$350

7B90P

500 ps/div to 500 ms/div
Calibrated Time Base

Fully Programmable Plug-in
7912 AD Digitizer only

400 MHz Trigger Bandwidth

Single-Sweep Operation

The programmable 7B90P is designed for use with a TEKTRONIX 7912AD Programmable Digitizer. Its operating functions can be manually selected at the front panel or selected under program control via the IEEE-488 bus. The only nonprogrammable functions are the Sweep Calibration adjustment and the External Trigger Input Terminator Switch.

CHARACTERISTICS

Sweep Rates — 500 ms/div to 10 ns/div in 24 steps. Magnifier extends fastest calibrated sweep rate to 500 ps/div.

Sweep Accuracy — Measured over center 8 div, +15°C to +35°C, with any 7000 Series programmable mainframe. Derate accuracies by an additional 1% for 0°C to +50°C.

| Time/Div | Unmagnified | Magnified |
|--------------------------|-------------|-----------|
| 500 ms/div to 100 ns/div | 2% | 3% |
| 50 ns/div to 10 ns/div | 3% | 4% |
| 500 ps/div | — | 5% |

Trigger Holdoff — Programmable in 62 steps between minimum and maximum.

| Time/Div | Min (ccw) | Max (cw) |
|-------------------------|-----------|----------|
| 500 ps/div to 2 μs/div | ≤3.5 μs | ≥90 μs |
| 5 μs/div to 20 μs/div | ≤35 μs | ≥900 μs |
| 50 μs/div to 200 μs/div | ≤350 μs | ≥9 ms |
| 500 μs/div to 2 ms/div | ≤3.5 ms | ≥90 ms |
| 5 ms/div to 500 ms/div | ≤35 ms | ≥900 ms |

Triggering Sensitivity —

P-P AUTO MODE

| Triggering Frequency Range | Min Signal Required | |
|----------------------------|---------------------|--------|
| | INT | EXT |
| At least 50 Hz | 2.0 div | 500 mV |
| 200 Hz to 50 MHz | 0.5 div | 125 mV |
| 50 MHz to 400 MHz | 1.5 div | 375 mV |

NORM Mode

| Coupling | Triggering Frequency Range | Min Signal Required | |
|------------------------|----------------------------|---------------------|--------|
| | | INT | EXT* |
| AC | 30 Hz to 50 MHz | 0.3 div | 100 mV |
| | 50 MHz to 400 MHz | 1.5 div | 250 mV |
| AC LF REJ ¹ | 30 kHz to 50 MHz | 0.3 div | 100 mV |
| | 50 MHz to 400 MHz | 1.5 div | 250 mV |
| AC HF REJ ² | 30 Hz to 50 kHz | 0.3 div | 100 mV |
| DC | Dc to 50 MHz | 0.3 div | 100 mV |
| | 50 MHz to 400 MHz | 1.5 div | 250 mV |

*EXT ÷ 10 operation attenuates external trigger signal 10 times.

¹Will not trigger on sinewaves or <8 div, INT, or 3 V, EXT, at or below 60 Hz.

²Will not trigger on 50 MHz sinewaves 1.5 div or less, INT, or 0.15 V or less, EXT.

Single-Sweep Mode — Same as NORM mode.

Trigger Level — Programmable in 0.05 div steps.

Horizontal Position — Programmable in 0.0125 div step unmagnified, 0.125 div step magnified.

7B90P

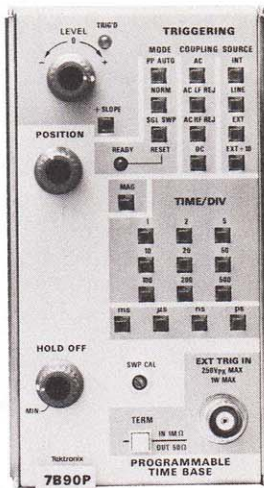

7B87

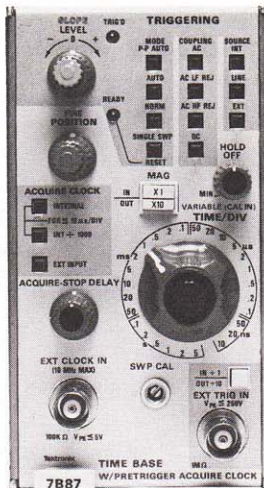

Internal Trigger Jitter — 0.1 ns or less at 400 MHz.

External Trigger Input — Selectable: 1 MΩ ±5%, 20 pF ±10% or 50 Ω ±5% with 1.22 max vswr at 400 MHz. Maximum input is 250 V (dc + peak ac) for 1 MΩ or 1 watt for 50 Ω or 1 watt for 50 Ω. The level range (excluding p-p AUTO) for a 1 kHz sinewave input is at least ±3 V in EXT and at least ±30 V in EXT ÷ 10.

Order 7B90P Programmable Time Base \$2650
7B87

1 ns/div to 5 s/div Calibrated Time Bases

Triggering to 400 MHz

Variable Trigger Holdoff

Pretrigger when used with 7854

The 7B87 is a time base designed for use with the 7854 Mainframe to provide additional pre-trigger capability. The pre-trigger feature is only compatible with the 7854 at this time. When used in the B horizontal of the 7854, the 7B87 provides both single shot and pre-trigger capability to the 7854.

The 7B87 has the same characteristics as the 7B80/7B85 time base plug-ins except for single shot pre-trigger capability. Pre-trigger allows you to view what has occurred before the trigger even in single shot applications. The amount of pre-trigger time is determined by the Acquire-Stop delay time setting. The total amount of pre-trigger is 0.2 to 9.9 times the time/div setting.

The INT ÷ 1000 control reduces the stored time/div to 1000 times slower than the real time display on a 7854. This does not, however, affect the Acquire-Stop delay time. The INT ÷ 1000 control allows stored sweep speeds from 10 ms to 5000 sec/div for slow speed applications.

An EXT CLOCK-IN connector is provided for clock frequencies other than what is offered by the INT clock of the 7B87.

CHARACTERISTICS

Sweep Rates — 5 s/div to 10 ns/div in 27 steps (1-2-5 sequence). X10 MAGNIFIER extends fastest calibrated sweep rate to 1 ns/div. The uncalibrated VARIABLE is continuous to at least 2.5 times the calibrated sweep rate.

Sweep Accuracy — Measured over the center 8 div, +15°C to +35°C, in the 7700, 7800, or 7900 Series Mainframes. Derate accuracies by an additional 1% for 0°C to +50°C.

| Time/Div ¹ | Unmagnified | Magnified |
|------------------------|-------------|-------------|
| 5 s/div to 1 s/div | 4% | Unspecified |
| 0.5 s/div to 50 ns/div | 1.5% | 2.5% |
| 20 ns/div to 10 ns/div | 2.5% | 4.0% |

¹Fastest calibrated sweep rate is limited by 7700 and 7600.

Trigger Holdoff Time —

| Minimum Holdoff Setting | 5 s/div to 1 μs/div | 2 times TIME/DIV setting or less |
|-------------------------|-------------------------|----------------------------------|
| | 0.5 μs/div to 10 ns/div | 2.0 μs or less |

Variable Holdoff Range — Extends holdoff time through at least 2 sweep lengths for rates of 20 ms/div or faster

Delay Time Range — 0.2 or less to at least 9.0 times TIME/DIV setting.

Jitter — 0.02% of TIME/DIV setting + 0.1 ns, or less.

TRIGGERING

Triggering Sensitivity (Auto and Norm Modes) — from repetitive signals)

| Coupling | Triggering Frequency Range ¹ | Min Signal Required | |
|------------------------|---|---------------------|--------|
| | | Int | Ext |
| AC | 30 Hz to 50 MHz | 0.3 div | 50 mV |
| | 50 MHz to 400 MHz | 1.5 div | 250 mV |
| AC LF REJ ² | 30 kHz to 50 MHz | 0.3 div | 50 mV |
| | 50 MHz to 400 MHz | 1.5 div | 250 mV |
| AC HF REJ | 30 Hz to 50 kHz | 0.3 div | 50 mV |
| DC ³ | Dc to 50 MHz | 0.3 div | 50 mV |
| | 50 MHz to 400 MHz | 1.5 div | 250 mV |

¹Triggering frequency ranges are limited to the frequency of the vertical system when operating in the Internal mode.

²Will not trigger on sinewaves of less than 8 div Int, or 3 V Ext, at or below 60 Hz.

³Triggering Frequency Range for dc coupling applies to frequencies above 30 Hz when operating in the Auto trigger mode.

Single Sweep — Requirements are same as for repetitive inputs.

Internal Trigger Jitter — 0.1 ns or less at 400 MHz.

Sensitivity (P-P AUTO Mode) — (ac or dc coupling)

| Triggering Frequency Range | Min Signal Required | |
|--|---------------------|--------|
| | Int | Ext |
| 200 Hz to 50 MHz | 0.5 div | 125 mV |
| 50 MHz to 400 MHz | 1.5 div | 375 mV |
| Low Frequency Response: At least 50 Hz | 2.0 | 500 mV |

External Trigger Input — Max input voltage is 250 V (dc + peak ac). Input R and C is 1 MΩ within 5% and 20 pF within 10%. The level range (excluding P-P AUTO) is at least ±1.5 V in EXT ÷ 1, and at least ±15 V in EXT ÷ 10.

Internal Clock — Pre-trigger 0.02048 Hz to 20.45 MHz determined by the time/div, X10 mag, and ÷1000 switches. Accuracy of Internal ÷ INT ÷ 1000 = 0.1%.

External Clock — Max input is 5 V pk. Input R is 100 KΩ within 5%. Threshold voltage TTL compatible. Max input freq. 10 MHz with BNC input. Delay 0.5 μs or less.

Acquire Stop Delay — Total range is 0.2 or less to at least 9.9 times Time/Div setting. Jitter from 5 s/div to 10 μs/div 0.07% of time/div setting or less. Delay accuracy (+15°C to +35°C) from 0.5 s/div to 10 μs/div is within 0.5% of measurement plus 5% of time/div setting.

Single Shot Performance — Using 7B87 with 7854 Internal Clock.

| Fastest Sweep (Time/Div) | Points per waveform |
|--------------------------|---------------------|
| 50 μs | 128 |
| 100 μs | 256 |
| 200 μs | 512 |
| 500 μs | 1024 |

Order 7B87 Time Base \$1480

7B10 and 7B15

7B15 Features:

Δ Time Measurements
with CRT Readout

Delayed Time Measurements
with CRT Readout

Vertical Trace Separation
between Two Delayed Sweeps

Both Feature:

0.2 ns/div to 0.2s/div Calibrated
Time Bases

Triggering to 1 GHz

Variable Trigger Holdoff

Peak-to-Peak Auto Triggering

The 7B10 and 7B15 are horizontal time bases designed for use with the 7104 Mainframe to provide optimum bandwidth/sweep-speed/compatibility, but may also be used with the 7700, 7800, and 7900 Series Mainframes. (Each may be used in any slower 7000 Series Mainframe with some reduction in sweep accuracy at the fastest sweep speed.)

The 7B10 and 7B15 or the 7B80 and 7B85 provide the Δ time measurement capability in addition to the standard delay time capability. Either time interval is digitally displayed on the CRT. A single intensified zone which you can position anywhere on the trace identifies the delay time interval (the time from the "A" or main sweep to the start of the intensified zone). Two intensified zones which you can position anywhere on a trace identify the Δ time interval (time between intensified zones). Alternate sweep switching makes it possible to display the information between the intensified zones full screen at the "B" sweep speed. By overlapping the two expanded waveforms, you are confident of the exact positioning of the intensified zones on the "A" sweep. This results in easy-to-make, precise and repeatable timing measurements.

By rotating the TRACE SEPARATION control out of the OFF position, the Δ time mode is activated. Two intensified zones can be independently positioned. As in the conventional delay mode, the DELAY TIME knob adjusts the time to the first intensified zone; the Δ TIME knob adjusts the time between the two intensified zones. Now, the CRT digital readout shows the Δ time between the two delays.

7B10

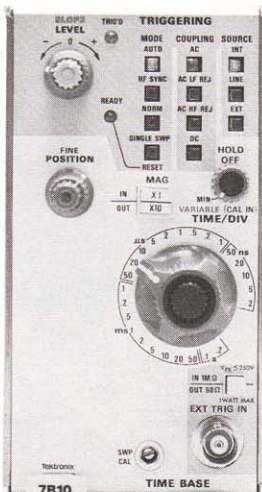

Delayed Time Base

Either plug-in can be used separately as an independent single time base, or they can be combined in any mainframe with two horizontal compartments for delaying and delayed operation.

CHARACTERISTICS

Sweep Rates — 0.2 s/div to 2 ns/div in 25 steps. X10 MAGNIFIER extends fastest calibrated sweep rate to 0.2 ns/div. The uncalibrated VARIABLE is continuous to at least 2.5 times the calibrated sweep.

Sweep Accuracy — Measured over the center 8 div, +15°C to +35°C, in the 7104, 7800 or 7900 Series Mainframe. Derate accuracies by an additional 1% for 0°C to +50°C.

| Time/Div ¹ | Unmagnified | Magnified |
|------------------------|-------------|-----------|
| 0.2 s/div to 10 ns/div | 2% | 3% |
| 5 ns/div and 2 ns/div | 3% | 4% |

¹Fastest calibrated sweep rate is limited by 7900, 7800, 7700, 7600 and 7300 Series Mainframes.

Trigger Holdoff Time —

| | Minimum | Maximum with VARIABLE |
|------------------------|-------------------------|--------------------------|
| 0.2 s/div to 50 ms/div | 40 ms | 400 ms |
| 20 ms/div to 2 μs/div | X2 the TIME/Div Setting | X20 the TIME/Div Setting |
| 1 μs/div to 0.5 μs/div | 2 μs | 20 μs |
| 0.2 μs/div to 2 ns/div | 2 μs | 6 μs |

Δ **Time Range** — 0 to at least 9 times TIME/DIV setting.

Δ **Time Accuracy** — Within (0.5% measurement plus 3 least significant digits) 20 ms/div to 100 ns/div.

7B15

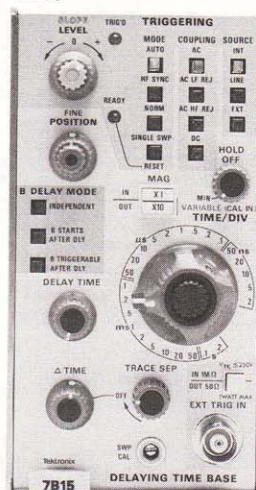

Δ Delaying Time Base

Trace Separation Range — Functional only in Δ Delay Time mode when alternating or chopping between time-base units. The second delayed sweep display can be vertically positioned at least 3 div below the first delayed sweep display.

Delay Time Range — 0.2 or less to at least 9.0 times TIME/DIV setting.

Jitter — 0.02% of TIME/DIV setting up through 50 μs/div. 0.03% of TIME/DIV setting plus 0.1 ns for sweep speeds of 20 μs/div through 100 ns/div.

TRIGGERING

Triggering Sensitivity

| Coupling | Triggering Frequency Range ² | Minimum Triggering Signal Required | |
|------------------------|---|------------------------------------|-----------------|
| | | Internal | External |
| Ac | 30 Hz to 250 MHz 250 MHz to 1 GHz | 0.5 div 1.5 div | 50 mV 150 mV |
| Ac Lf REJ ² | 50 kHz to 250 MHz 250 MHz to 1 GHz | 0.5 div 1.5 div | 50 mV 150 mV |
| Ac Hf REJ | 30 Hz to 40 kHz | 0.5 div | 50 mV |
| Dc ³ | Dc to 250 MHz 250 MHz to 1 GHz | 0.5 div 1.5 div | 50 mV 150 mV |

¹The triggering frequency ranges given here are limited to the -3 dB frequency of the oscilloscope vertical system when operating in the internal mode.

²Will not trigger on sinewaves at or below 60 Hz when amplitudes are < 8 divisions internal or 3 volts External.

³The Triggering Frequency Range for DC COUPLING applies to frequencies above 30 Hz when operating in the AUTO TRIGGERING MODE.

Single Sweep — Requirements are the same as for repetitive inputs.

Internal Trigger Jitter — 30 ps or less at 1 GHz.

Hf Sync Mode — 250 MHz to 1 GHz, .3 div internal and .75 mV external.

External Trigger Input — Max input voltage is 250 V (dc + peak ac) for 1 MΩ input, 1 W average for 50 Ω input. Input R and C for 1 MΩ input is 1 MΩ within 5%, 20 pF within 10%; for 50 Ω input, 50 Ω within 2%. Level range is at least ±3.5 V in EXT ÷ 1.

ORDERING INFORMATION

| | |
|-------------------------------|--------|
| 7B10 Time Base | \$1980 |
| 7B15 Delaying Time Base | \$2245 |

7B80 and 7B85

7B85 Features:

Δ Time Measurements with CRT Readout

Delayed Time Measurements with CRT Readout

Vertical Trace Separation Between Two Delayed Sweeps

Both Feature:

1 ns/div to 5 s/div Calibrated Time Bases

Triggering to 400 MHz

Variable Trigger Holdoff

Peak-to-Peak Auto Triggering

The 7B80 and 7B85 are horizontal time bases recommended for use with 7700, 7800 and 7900 Series Mainframes to provide optimum bandwidth/sweep-speed compatibility. (Each may be used in any slower 7000 Series Mainframe with some reduction in sweep accuracy at the fastest sweep speed.)

Either plug-in can be used separately as an independent single time base, or they can be combined in any mainframe with two horizontal compartments for delaying and delayed operation.

X-Y displays are available using a 7B80 with Option 02. A front-panel button (DISPLAY MODE) selects either normal sweep or X-Y display. Both signals are applied to vertical (Y) amplifiers, and the desired horizontal (X) signal is then routed through plug-in and mainframe trigger paths to the 7B80. An X-Y mode selection then applies the signal to the horizontal deflection system.

CHARACTERISTICS

Characteristics are common to both units unless otherwise noted.

Sweep Rates — 5 s/div to 10 ns/div in 27 steps (1-2-5 sequence). X10 MAGNIFIER extends fastest calibrated sweep rate to 1 ns/div. The uncalibrated VARIABLE is continuous to at least 2.5 times the calibrated sweep rate.

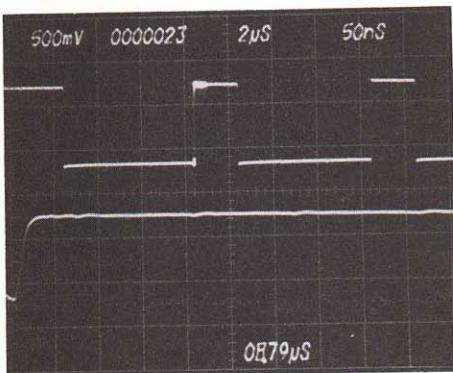
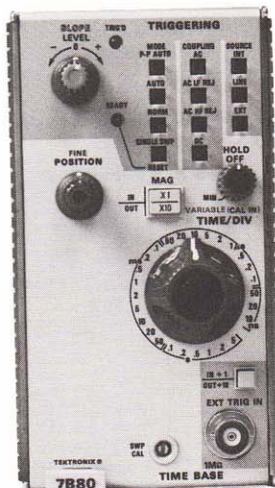

figure 1. Delaying and delayed sweeps are shown with the mainframe selecting ALT sweep modes. The delay time to the start of the delayed sweep is digitally presented on the lower edge of the CRT.

7B80



Delayed Time Base

Sweep Accuracy — Measured over the center 8 div. +15°C to +35°C, in the 7700, 7800, or 7900 Series Mainframe. Derate accuracies by an additional 1% for 0°C to +50°C.

| Time/Div ¹ | Unmagnified | Magnified |
|------------------------|-------------|-------------|
| 5 s/div to 1 s/div | 4% | Unspecified |
| 0.5 s/div to 50 ns/div | 1.5% | 2.5% |
| 20 ns/div to 10 ns/div | 2.5% | 4.0% |

¹Fastest calibrated sweep rate is limited by 7700 and 7600.

Trigger Holdoff Time —

| Minimum Holdoff Setting | 5 s/div to 1 μs/div | 0.5 μs/div to 10 ns/div | 2 times TIME/DIV setting or less | 2.0 μs or less |
|-------------------------|--|-------------------------|----------------------------------|----------------|
| Variable Holdoff Range | Extends holdoff time through at least 2 sweep lengths for rates of 20 ms/div or faster | | | |

Δ Time Range — 0 to at least 9 times TIME/DIV setting.

Δ Time Accuracy — (+15°C to +35°C) Within (0.5% measurement + 0.3% of TIME/DIV setting + 1 least significant digit) from 20 ms/div to 100 ns/div.

Trace Separation Range — Functional only in Δ Delay Time mode when alternating or chopping between time-base units. The second delayed sweep display can be vertically positioned at least 3 div below the first delayed sweep display.

Delay Time Range — 0.2 or less to at least 9.0 times TIME/DIV setting.

Jitter — 0.02% of TIME/DIV setting + 0.1 ns, or less.

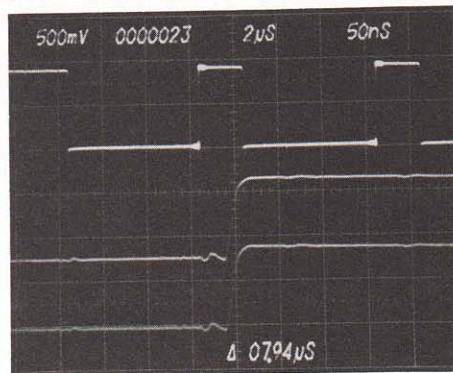
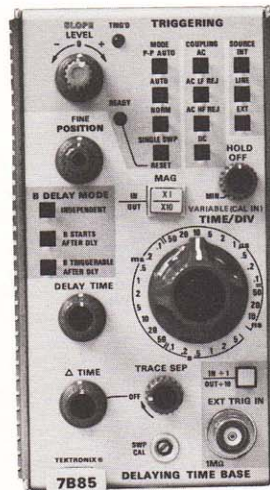

figure 2. With the mainframe still selecting ALT sweeps, delaying and both delayed sweeps are shown. The digital readout on the lower CRT edge shows the time between the two sweep delays. The TRACE SEPARATION knob is used to position the second delayed sweep below the first delayed sweep with up to 3 div of separation.

7B85



Δ Delaying Time Base

TRIGGERING

Triggering Sensitivity (Auto and Norm Modes) — (from repetitive signals)

| Coupling | Triggering Frequency Range ¹ | Min Signal Required | |
|------------------------|---|---------------------|-----------------|
| | | Int | Ext |
| Ac | 30 Hz to 50 MHz 50 MHz to 400 MHz | 0.3 div 1.5 div | 50 mV 250 mV |
| Ac Lf REJ ² | 30 kHz to 50 MHz 50 MHz to 400 MHz | 0.3 div 1.5 div | 50 mV 250 mV |
| Ac Hf REJ | 30 Hz to 50 kHz | 0.3 div | 50 mV |
| Dc ³ | Dc to 50 MHz 50 MHz to 400 MHz | 0.3 div 1.5 div | 50 mV 250 mV |

¹Triggering frequency ranges are limited to the frequency of the vertical system when operating in the Internal mode.

²Will not trigger on sine waves of less than 8 div Int, or 3 V Ext, at or below 60 Hz.

³Triggering Frequency Range for dc coupling applies to frequencies above 30 Hz when operating in the Auto triggering mode.

Single Sweep — Requirements are same as for repetitive inputs.

Internal Trigger Jitter — 0.1 ns or less at 400 MHz.

Sensitivity (P-P AUTO Mode) — (ac or dc coupling)

| Triggering Frequency Range | Min Signal Required | |
|---|---------------------|--------|
| | Int | Ext |
| 200 Hz to 50 MHz | 0.5 div | 125 mV |
| 50 MHz to 400 MHz | 1.5 div | 375 mV |
| Low Frequency Response: At least 50 Hz | 2.0 div | 500 mV |

External Trigger Input — Max input voltage is 250 V (dc + peak ac). Input R and C is 1 MΩ within 5% and 20 pF within 10%. The level range (excluding P-P AUTO) is at least ±1.5 V in EXT ÷ 1, and at least ±15 V in EXT ÷ 10.

7B80 Option 02 —

X-Y Phase Shift — (Determined by the circuitry in mainframe) — For mainframe without X-Y horizontal compensation, the mainframe phase shift specifications are retained for frequencies of 50 kHz and below. For mainframes with optional X-Y horizontal compensation, the extra delay adds to the phase shift error above 50 kHz.

ORDERING INFORMATION

7B80 Time Base \$1255
7B85 Delaying Time Base \$1510

7B80 OPTION

Option 02, X-Y Add \$100

7B92A

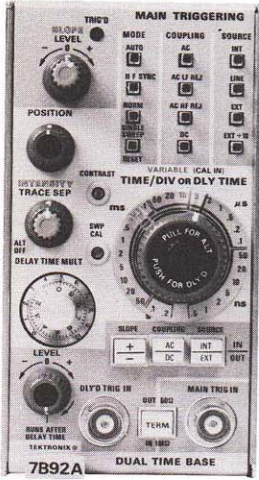

Dual Time Base

7B92A

0.5 ns/div to 0.2 s/div Calibrated Time Base

Triggering to 500 MHz

Alternate Display of Intensified Delaying and Delayed Sweeps

Contrast Regulation between Delaying and Delayed Sweeps

The 7B92A Dual Time Base is recommended for use only in the 7800 and 7900 Series Mainframes (the 7B92A may be used in all other mainframes at slower sweep speeds).

There are four display modes: normal sweep, intensified delaying sweep, delayed sweep, and alternate sweep (excepting alternate in R7704). When operating in the AUTO mode of main triggering, a bright base line is displayed in the absence of a trigger signal.

DELAYING SWEEP (MAIN SWEEP)

Sweep Rate — 0.2 s/div to 10 ns/div in 23 calibrated steps (1-2-5 sequence). An uncalibrated variable rate is continuous between steps, and extends sweep rate to at least 0.5 s/div. The VARIABLE control is internally switchable between delaying and delayed sweeps.

Sweep Accuracy — Measured over the center 8 div in a 7900 Family Oscilloscope:

| Time/Div | +15°C to +35°C | 0°C to +50°C |
|------------------------|----------------|--------------|
| 0.2 s/div to 20 ns/div | Within 2% | Within 3% |
| 10 ns/div | Within 3% | Within 4% |

Delay Time Multiplier Range — 0 to 9.8 times the DLY TIME-DIV setting from 0.2 s/div to 10 ns/div (0 to 1.96 s).

Differential Delay Time Measurement Accuracy — (+15°C to +35°C).

Sweep Speed

| | | |
|------------------------------|--|--|
| 0.2 s/div to 0.1 μ s/div | Both delay time mult dial settings at 0.5 or greater | $\pm(0.75\%$ of measurement + 0.25% of full scale) |
| | One or both delay time mult dial settings at less than 0.5 | $\pm(0.75\%$ of measurement + 0.5% of full scale + 5 ns) |
| 50 ns/div to 10 ns/div | Both delay times equal to or greater than 25 ns | $\pm(1\%$ of measurement + 0.5% of full scale) |
| | One or both delay times less than 25 ns | $\pm(1\%$ of measurement + 1% of full scale + 5 ns) |

Full scale is 10 times the TIME/DIV or DLY TIME setting. Accuracy applies over the center 8 Delay Time Multiplier div from +15°C to +35°C.

Delay Time Jitter — Not applicable for the first 2% of max available delay time (DELAY TIME MULT dial setting >0.2).

| | |
|-----------------------------|---|
| 0.2 s/div to 50 μ s/div | 1 part in 50,000 of the max available delay time |
| 20 μ s/div to 10 ns/div | 1 part in 50,000 of the max available delay time + 0.5 ns |

Max available delay time is 10 times the TIME/DIV or DLY TIME switch setting.

MAIN TRIGGERING

Auto, Norm

| Coupling | Triggering Frequency Range | Min Signal Required | |
|------------|----------------------------|---------------------|--------|
| | | Int | Ext |
| Ac | 30 Hz-20 MHz | 0.5 div | 100 mV |
| | 20 MHz-500 MHz | 1.0 div | 500 mV |
| Ac Lf REJ* | 30 kHz-20 MHz | 0.5 div | 100 mV |
| | 20 MHz-500 MHz | 1.0 div | 500 mV |
| Ac Hf REJ | 30 Hz-50 kHz | 0.5 div | 100 mV |
| Dc | Dc-20 MHz | 0.5 div | 100 mV |
| | 20 MHz-500 MHz | 1.0 div | 500 mV |

EXT \div 10 switch attenuates external signal 10 times.

Hf Sync — Triggering sensitivity is 0.5 div INT or 100 mV EXT, from 100 MHz to 500 MHz for any coupling except Ac Hf Rej.

Single Sweep — Triggering requirements are the same as normal sweep. When triggered, time base produces one sweep only until reset.

Internal Trigger Jitter — 50 ps or less at 500 MHz.

External Trigger Input — Selectable 50 Ω or 1 M Ω inputs (1 M Ω is paralleled by \approx 20 pF). Max safe input is 250 V (dc + peak ac) for 1 M Ω input and 1 W average for 50 Ω input. Range of trigger level is at least \pm 3.5 V in EXT, and at least \pm 35 V in EXT \div 10.

DELAYED SWEEP

Sweep Rate — 0.2 s/div to 0.5 ns/div in 27 steps (1-2-5 sequence). An uncalibrated variable rate is continuous between steps, and extends sweep rate to at least 0.5 s/div. The VARIABLE control is internally switchable between delaying and delayed sweeps.

Sweep Accuracy — Measured over the center 8 div in a 7900 Family Oscilloscope:

| Time/Div | +15°C to +35°C | 0°C to +50°C |
|------------------------|----------------|--------------|
| 0.2 s/div to 20 ns/div | Within 2% | Within 3% |
| 10 ns/div to 5 ns/div | Within 3% | Within 4% |
| 2 ns/div to 1 ns/div | Within 4% | Within 5% |
| 0.5 ns/div | Within 5% | Within 6% |

Delayed Triggering

| Coupling | Triggering Frequency Range | Min Signal Required | |
|----------|----------------------------|---------------------|--------|
| | | Int | Ext |
| Ac | 30 Hz to 20 MHz | 0.5 div | 100 mV |
| | 20 MHz to 500 MHz | 1.0 div | 500 mV |
| Dc | DC to 20 MHz | 0.5 div | 100 mV |
| | 20 MHz to 500 MHz | 1.0 div | 500 mV |

Internal Trigger Jitter — 50 ps or less at 500 MHz.

External Trigger Input — Selectable 50 Ω or 1 M Ω inputs (1 M Ω is paralleled by \approx 20 pF). Max safe input is 250 V (dc + peak ac) for 1 M Ω input, and 1 W average for 50 Ω input. Range of trigger level is at least \pm 3.5 in EXT.

Order 7B92A Dual Time Base \$2985

7B53A

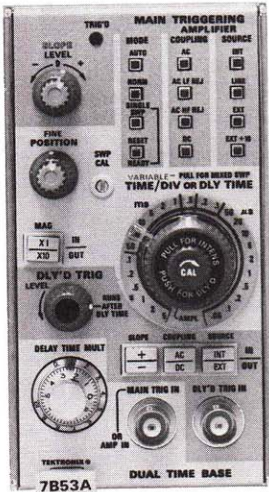

Dual Time Base

7B53A

5 ns/div to 5 s/div Calibrated Time Base

Calibrated Mixed Sweep

Triggering to 100 MHz

Single-Sweep Operation

Optional TV Sync-Separator Triggering

The easy-to-use 7B53A Dual Time Base is recommended for use with 7600 Mainframes to provide optimum bandwidth/sweep-speed compatibility. It may, however, be used in any 7000 Series Mainframe. The fastest rate (5 ns/div) is obtained with the X10 MAGNIFIER.

The 7B53A Time Base features four kinds of sweep: normal, intensified delaying, delayed, and mixed. The pushbutton switches cannot be lit.

DELAYING SWEEP

Sweep Rate — 0.05 μ s/div to 5 s/div in 25 steps (1-2-5 sequence). 5 ns/div, the fastest calibrated sweep rate, is obtained with the X10 MAGNIFIER. The uncalibrated VARIABLE is continuous between steps. The variable control is internally switchable between main, delayed-sweep, and variable main-sweep holdoff.

Sweep Accuracy — Measured over the center 8 div.

| Time/Div | Unmagnified | | Magnified | |
|-------------------------------|----------------|--------------|----------------|--------------|
| | +15°C to +35°C | 0°C to +50°C | +15°C to +35°C | 0°C to +50°C |
| 5 s/div to 1 s/div | 3% | 4% | * | * |
| 0.5 s/div to 0.05 μ s/div | 3% | 4% | 3.5% | 5% |
| 50 ms/div to 0.5 μ s/div | 2% | 3% | 2.5% | 4% |

*Unspecified

Delay Time Multiplier Range — 0 to 10 times the DELAY TIME/DIV setting from 5 s/div to 1 μ s/div.

Differential Delay Time Measurement Accuracy — 5 s/div to 1 s/div \pm 1.4% of measurement + 0.3% of full scale; 0.5 s/div to 1 μ s/div: \pm 0.7% of measurement + 0.3% of full scale. Full scale is 10 times the DELAY TIME/DIV setting. Accuracy applies over the center 8 DTM divisions from +15°C to +35°C.

Jitter — 0.05% or less of TIME/DIV setting.

Triggering —

| Coupling | Triggering Frequency Range | Min Signal Required | |
|------------|---|---------------------|------------------|
| | | Int | Ext |
| Ac | 30 Hz-10 MHz 10 MHz-100 MHz | 0.3 div 1.5 div | 100 mV 500 mV |
| Ac Lf REJ* | 30 kHz-10 MHz 150 kHz-10 MHz 10 MHz-100 MHz | 0.3 div 1.5 div | 100 mV 500 mV |
| Ac Hf REJ | 30 Hz-50 kHz | 0.3 div | 100 mV |
| Dc | Dc-10 MHz 10 MHz-100 MHz | 0.3 div 1.5 div | 100 mV 500 mV |

*Will not trigger on sinewaves of 3 div or less INT or 1.5 V EXT below 120 Hz.

Single Sweep — Triggering requirements are the same as normal sweep. When triggered, sweep generator produces one sweep only until reset.

Internal Trigger Jitter — 1 ns or less at 75 MHz.

External Trigger Input — Max input voltage is 500 V (dc + peak ac), 500 V p-p ac at 1 kHz or less. Input R and C is 1 M Ω within 2%, 20 pF within 2 pF. LEVEL range is at least +1.5 V to -1.5 V in EXT, at least +15 V to -15 V in EXT \div 10.

DELAYED SWEEP

Sweep Rate — 0.05 μ s/div to 0.5 s/div in 22 steps (1-2-5 sequence). 5 ns/div, the fastest calibrated sweep rate, is obtained with the X10 MAGNIFIER. The uncalibrated VARIABLE is continuous between steps to at least 1.25 s/div and is switchable between the main, delayed sweep, and variable main sweep holdoff.

Sweep Accuracy — Measured over the center 8 div.

| Time/Div | Unmagnified | | Magnified | |
|--|----------------|-------------|----------------|-------------|
| | +15°C to +35°C | 0°C to 50°C | +15°C to +35°C | 0°C to 50°C |
| 0.5 s/div to 0.1 s/div and 0.2 μ s/div to 0.05 μ s/div | 4% | 5% | 4.5% | 6% |
| 50 ms/div to 0.5 μ s/div | 3% | 4% | 3.5% | 5% |

Delayed Sweep Gate — Output voltage is \approx +3.5 V into at least 10 k Ω ; shunted by 100 pF or less, or 0.5 V into 50 Ω . Rise time is 50 ns or less; output R is 350 Ω within 10%. Gate is available at the DLY'D TRIG IN connector when the delayed sweep source switch is set to INT.

Triggering —

| Coupling | Triggering Frequency Range | Min Signal Required | |
|----------|--------------------------------|---------------------|------------------|
| | | Int | Ext |
| Ac | 30 Hz-10 MHz 10 MHz-100 MHz | 0.3 div 1.5 div | 100 mV 500 mV |
| Dc | Dc-10 MHz 10 MHz-100 MHz | 0.3 div 1.5 div | 100 mV 500 mV |

Internal Trigger Jitter — 1 ns or less at 75 MHz.

External Trigger Input — Max input voltage is 500 V (dc + peak ac), 500 V p-p ac at 1 kHz or less. Input R and C is 1 M Ω within 2%, 20 pF within 2 pF. LEVEL range is at least +1.5 V to -1.5 V in EXT.

MIXED SWEEP

Sweep Accuracy — Within 2% plus measured main sweep error. Exclude the following portions of mixed sweep: first 0.5 div after start of main sweep display and 0.2 div or 0.1 μ s (whichever is greater) after transition of main to delayed sweep.

EXT HORIZONTAL INPUT

Deflection Factor — 10 mV/div within 10% when in EXT, MAG X10; 100 mV/div within 10% when in EXT; 1 V/div within 10% when in EXT \div 10.

Bandwidth

| Coupling | Lower -3 dB | Upper -3 dB |
|-----------|-------------|-------------|
| Ac | 40 Hz | 2 MHz |
| Ac Lf REJ | 16 kHz | 2 MHz |
| Ac Hf REJ | 40 Hz | 100 kHz |
| Dc | Dc | 2 MHz |

TV SYNC

Option 05, TV Sync Separator Triggering — Permits stable internal line or field rate triggering from displayed composite video or composite sync waveforms. Conventional waveform displays and measurements can be made from standard broadcast or closed circuit tv systems, domestic or international, with up to 1201-line, 60 Hz field rates. Individual lines may be displayed with delayed sweep features. The wide range of delayed sweeps permits accurate alternate-frame, color-burst observations in the PAL color system. Option 05 deletes ac line trigger and External \div 10 from trigger source.

ORDERING INFORMATION

| | |
|--------------------------------|-----------|
| 7B53A Dual Time Base | \$1380 |
| 7B53A OPTION | |
| Option 05, TV Triggering | Add \$150 |

7B50A

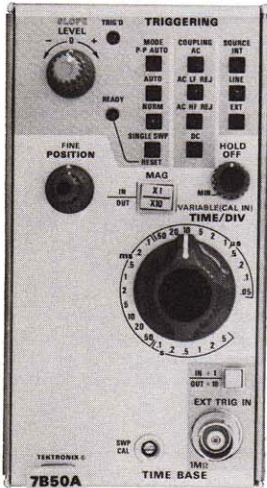

Time Base

7B50A

5 ns/div to 5 s/div Calibrated Time Base

Triggering to 150 MHz

Variable Trigger Holdoff

Peak-to-Peak Auto Triggering

Single-Sweep Operation

The easy-to-use 7B50A Time Base is recommended for use with 7600 Series Mainframes to provide optimum bandwidth/sweep-speed compatibility. It may, however, be used in any 7000 Series Mainframe. The fastest rate (5 ns/div) is obtained with the X10 MAGNIFIER.

This time base features expanded capability in maximum triggering frequency — now 150 MHz — and variable trigger holdoff — for stability on lengthy asynchronous data trains.

Pushbutton positions select triggering mode, coupling method, and source. For routine applications, hands-off triggering is accomplished by actuating three switches: INT SOURCE, AC COUPLING, and P-P AUTO MODE. The P-P AUTO MODE provides a base line trace in the absence of a signal and a triggered trace at any position of the LEVEL/SLOPE control when a signal of 0.5 div or greater is present. Except for the selection of + or - SLOPE this mode is automatic. The other triggering positions are useful for specific applications.

Ac Lf REJ attenuates undesirable trigger components below 30 kHz. Ac Hf REJ attenuates components above 50 kHz, which can cause triggering problems during low-frequency applications. Single-sweep functions with lighted READY indicator and manual reset are associated with the trigger mode controls.

X-Y displays are available with Option 02 installed. A front-panel button (DISPLAY MODE) selects either normal sweep or X-Y display. Both signals are applied to vertical (Y) amplifiers and the desired horizontal (X) signal is then routed through plug-in and mainframe trigger paths to the 7B50A. An X-Y mode selection then applies the signal to the horizontal deflection system.

CHARACTERISTICS

Sweep Rates — 0.05 μ s/div to 5 s/div in 25 steps (1-2-5 sequence). 5 ns/div, the fastest calibrated sweep rate, is obtained with the X10 MAGNIFIER. The uncalibrated VARIABLE allows continuous sweep rate selection between steps.

Sweep Accuracy — Measured over center 8 div, +15°C to +35°C, with any 7000 Series Mainframe. Derate accuracies by an additional 1% each for 0°C to +50°C.

| Time/Div | Unmagnified | Magnified |
|-------------------------------------|-------------|-----------|
| 5 s/div to 1 s/div | 4% | * |
| 0.5 s/div to 0.5 μ s/div | 2% | 3% |
| 0.2 μ s/div to 0.05 μ s/div | 3% | 4% |

* Unspecified

Trigger Holdoff Time —

| | | |
|------------------------|--|----------------------------------|
| MIN Holdoff Setting | 5 s/div to 1 μ s/div | 2 times TIME/DIV setting or less |
| | 0.5 μ s/div to 50 ns/div | 2.0 μ s or less |
| Variable Holdoff Range | Extends holdoff time through at least 2 sweep lengths for sweep rates of 20 ms/div or faster | |

Triggering —

Sensitivity (AUTO and NORM modes)

| Coupling | Triggering Frequency Range ¹ | Min Signal Required | |
|------------------------|---|---------------------|--------|
| | | Int | Ext |
| Ac | 30 Hz to 50 MHz | 0.3 div | 50 mV |
| | 50 MHz to 150 MHz | 1.5 div | 250 mV |
| Ac Lf REJ ² | 30 kHz to 50 MHz | 0.3 div | 50 mV |
| | 50 MHz to 150 MHz | 1.5 div | 250 mV |
| Ac Hf REJ | 30 Hz to 50 kHz | 0.3 div | 50 mV |
| Dc ³ | Dc to 50 MHz | 0.3 div | 50 mV |
| | 50 MHz to 150 MHz | 1.5 div | 250 mV |

¹Triggering frequency ranges are limited to the frequency of the vertical system when operating in the internal mode.

²Will not trigger on sinewaves of less than 8 div INT, or 3 V EXT, at or below 60 Hz.

³Triggering Frequency Range for dc coupling applies to frequencies above 30 Hz when operating in the Auto Triggering mode.

Sensitivity (P-P AUTO MODE) (Ac or Dc Coupling)

| Triggering Frequency Range | Min Signal Required | |
|----------------------------|---------------------|--------|
| | Int | Ext |
| 200 Hz to 50 MHz | 0.5 div | 125 mV |
| 50 MHz to 150 MHz | 1.5 div | 375 mV |

Option 02

X-Y Phase Shift — (Determined by the circuitry in mainframe) — For mainframes without X-Y horizontal compensation, the mainframe phase shift specification is retained for frequencies of 50 kHz and below. For mainframes with optional X-Y horizontal compensation, the extra delay adds to the phase shift error above 50 kHz.

ORDERING INFORMATION

7B50A Time Base \$840

7B50A OPTION

Option 02, X-Y Add \$100

7D11



Digital Delay Unit

7D11

Delay by Time or Events

Digital Delay Readout to 7 1/2 Digits

100 ns to 1 s Delay Time

1 ns Resolution

2.2 ns Delay Time Jitter

0.5 ppm (± 2 ns) Accuracy

Delay Interval CRT Display

The 7D11 Digital Delay Plug-in gives stable delayed triggers for measurements requiring low jitter. The 7D11 also provides precision time delays. The 7D11 may be used in any compartment of a 7000 Series Mainframe equipped with CRT readout. It provides a variety of outputs.

The delay-by events mode is used to eliminate jitter in mechanically based systems such as disc file memories. It is also useful for selecting a certain time frame in data for analysis and for making other measurements under complex timing conditions.

In the delay-by events, the 7D11 counts arbitrary trigger events, periodic or aperiodic, and delivers an output after the preselected count has been reached (see fig 2).

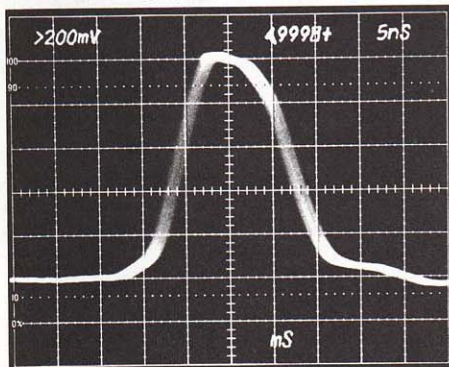

figure 1. Delay-by-time. A 0.2 μ s time marker delayed 4.9998 ms by the 7D11 and displayed at 5 ns/div.

An accurate and jitter-free delay-by-time is very useful when working with digital logic, pcm telemetry, sonar, radar, shock tube testing, and delay line measurements, to name a few. On receipt of a trigger, the 7D11 in the delay-by-time mode counts a highly accurate clock; at the selected delay time, it delivers a delayed trigger to its front-panel connector and mainframe. In both modes, delay time or number of events to be counted is selected by a single front-panel control.

When the 7D11 is installed in a vertical compartment, the CRT can display a waveform that lasts for the duration of the delay interval. This waveform may be displayed together with the signal waveform the 7D11 triggers on. From a vertical compartment, the 7D11 can trigger a time base such as 7B80, 7B53A, or another 7D11 through the internal mainframe trigger path.

In any horizontal compartment, the 7D11 generates a display similar to the "A intensified by B" mode of conventional delayed sweep (see fig 2). When used in the A horizontal compartment, the 7D11 B sweep delay mode controls will permit the B sweep to run after the delay generated by the 7D11. This delay interval is also available at the front panel for such uses as gated interval counter measurements and generating pulses of highly accurate width.

In delay-by-events, an external pulse (events start trigger) may be used to enable counting of the events. In such applications as a line selector on a video monitor, the vertical sync pulse is the events start trigger. Then the 7D11 counts "n" number of horizontal sync pulses (events) into the field or frame. In a similar manner, the origin pulse of a disc memory can be used as the events start trigger, and the disc clock pulses become the events that are counted.

For timing measurements that require a higher degree of accuracy than the 0.5 ppm source available in the 7D11, the delay-by-time clock may be referenced to an external 1 MHz timing standard through the EXT 1 MHz input.

Time delay resolution up to 1 ns may be obtained by using the front-panel fine delay control.

By setting an internal switch, the indicated delay time is half the actual delay time. In such applications as TDR, radar timing, etc, the CRT readout would display the "one-way-trip" time.

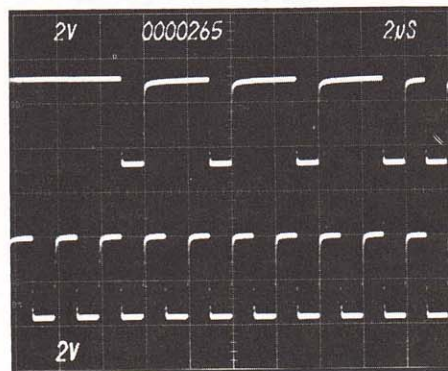

figure 2. Delay-by-events. The lower trace is the master clock in our logic circuit. The top trace is our data which is delayed by 265 clock pulses.

EVENTS DELAY

- Events Delay Range — One to 10^7 events.
- Delay Increment — One event.
- Insertion Delay — 35 ns \pm 5 ns.
- Recycle Time — $<$ 500 ns.
- Max Event Frequency — At least 50 MHz.

TRIGGERING External Trigger

| | |
|-------------------|--|
| Source | Int, Line, Ext, Ext \div 10 |
| Coupling | Dc, Ac, Ac Lf Rej, Ac Hf Rej |
| Max Input Voltage | 250 V Dc + peak Ac |
| Level Range | \pm 1.75 V in Ext \pm 17.5 V in Ext \div 10 |
| Input R and C | 1 M Ω \pm 5%, 20 pF \pm 2 pF |

| | Coupling | Frequency Range | Min Signal Required | |
|-------------|------------|--|---------------------|-----------------------|
| | | | Int | Ext |
| Sensitivity | Ac | 30 kHz-10 MHz 10 MHz-50 MHz | 0.3 div 1.0 div | 150 mV 750 mV |
| | Ac Lf Rej* | 30 kHz-10 MHz 150 kHz-10 MHz 10 MHz-50 MHz | 0.3 div 1.0 div | — 150 mV 750 mV |
| | Ac Hf Rej | 30 Hz-50 kHz | 0.3 div | 150 mV |
| | Dc | Dc-10 MHz 10 MHz-50 MHz | 0.3 div 1.0 div | 150 mV 750 mV |

*Will not trigger on sine waves of 3 div or less INT or 1.5 V EXT below 120 Hz.

Events Start Trigger

| | |
|-------------------|--|
| Source | External Only |
| Coupling | Dc Only |
| Max Input Voltage | 150 V dc + peak ac |
| Level Range | \pm 3 V |
| Input R and C | 1 M Ω within 5%, 20 pF \pm 2 pF |
| Sensitivity | 100 mV minimum, 30 Hz to 2 MHz; increasing to 250 mV, 2 MHz to 20 MHz; increasing to 500 mV, 20 MHz to 50 MHz. |

TIME DELAY

Digital Delay Range — Normal mode: 100 ns to 1 s in 100 ns increments. Echo mode: 200 ns to 2 s in 200 ns increments.

Analog Delay — Continuously variable from 0 to at least 100 ns, accuracy within 2 ns of indicated delay.

Jitter with Internal Clock — 2.2 ns or delay time x 10^{-7} , whichever is greater.

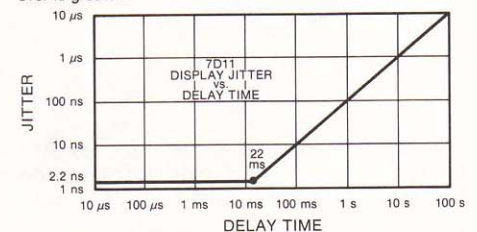

Insertion Delay — Zero within 2 ns.

Recycle Time — Less than 575 ns.

Time Base — 500 MHz oscillator phase-locked to internal or external clock.

Internal Clock — 5 MHz crystal oscillator. Accuracy is 0.5 ppm.

External Clock — 1 MHz within 1%, ac coupled, 50 Ω .

OUTPUTS

Delayed Trigger Out — Amplitude: 2 V or greater into open circuit, 1 V or greater into 50 Ω . Rise time into 50 Ω load: 2 ns or less. Fall time into 50 Ω load: 5 ns or less. Pulse width: 200 to 250 ns.

Delay Interval Out — Amplitude: 2 V or greater into open circuit, 1 V or greater into 50 Ω . Rise time into fall time: 5 ns or less. Accuracy: equal to delay interval less 20 to 30 ns.

READOUT

Display — 7 1/2 digit with leading zero suppression, ms legend in time delay mode. Plus (+) symbol reminds the operator to add on the FINE DELAY (ns) setting.

Order 7D11 Digital Delay Unit \$2735

7D15

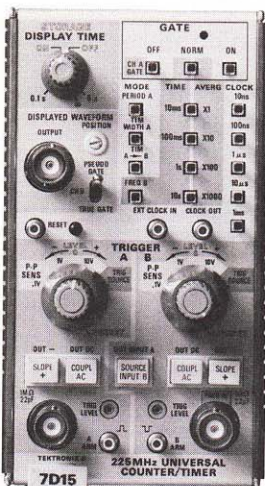

225 MHz Counter/Timer

7D15

Oscilloscope-controlled Time and Frequency Measurements

10 ns "Single-shot" Time Interval Measurement Resolution

Time Interval Averaging

CRT Display of Counting Interval

10 ps Period-Averaging Resolution

Frequency Measurements Directly to 225 MHz

Signal Conditioning via Mainframe Trigger Source

The 7D15 is a universal counter/timer designed for use in all 7000 Series Oscilloscope Mainframes with CRT readout.

The 7D15 offers all the measurement capabilities of the counter/timer, such as time interval, period, frequency, frequency ratio, totalize, and manual stop watch.

Three displays, the pseudo gate, Ch B Schmitt trigger output, and true gate, are selected by a 7D15 front panel switch and are also available at a front panel connector.

The 7D15 can also be completely controlled by the oscilloscope's delayed gate. Arming inputs are provided for each channel. By using the delayed B gate to control the start and stop count points, visually selective measurements can be made at any point on the CRT display.

Two identical high-speed trigger circuits provide complete signal processing. Identical trigger circuits also allow single-shot time interval measurements to be made with 10 ns resolution. With repetitive signals, time interval averaging will increase the accuracy of a measurement by a factor of ten or more.

Modes of Operation

| | | |
|--|-------------------------------|--|
| Frequency Mode | Range | Dc to 225 MHz Resolution 0.1 Hz maximum |
| | Accuracy | $\epsilon_{\text{freq(Hz)}} = \pm TB \cdot f_{\text{in}} \pm \frac{1}{T}$ |
| Period and Multi-Period Mode | Range | 10 ns to 10 ⁵ seconds with averaging times of X1 to X1000 in decade steps. Resolution: 10 picoseconds maximum |
| | Accuracy | $\epsilon_{\text{period(s)}} = \pm TB \cdot P_{\text{in}} \pm \frac{10^{-9}}{M} \pm \frac{2E_{\text{npk}}}{\frac{dv}{dt} \cdot M} \pm \frac{P_{\text{ck}}}{M}$ |
| Time Interval TI and (TI Average) Mode | Range | 6 ns to 10 ⁵ seconds with averaging times of X1 to X1000. 0.1 ns resolution (usable) |
| | Accuracy Worst Case (Nominal) | $\epsilon_{\text{TI(s)}} = \pm TB \cdot P_{\text{in}} \pm \frac{P_{\text{ck}}}{\sqrt{M}} \pm 10^{-9} \pm \frac{2E_{\text{npk}}}{\frac{dv}{dt}}$ |
| Frequency Ratio, CH B/Ext Clock | Range | 10 ⁻⁷ to 10 ⁴ |
| Manual Stop Watch | Range | 0 to 10 ⁵ seconds |
| Totalize, Ch B | Range | 0 to 10 ⁸ counts |

NOTE: Formulas given where ϵ is the error; TB (expressed as a decimal) is the time base accuracy; P_{in} is the period or time interval of unknown signal; M is the number of averages given; P_{ck} is the measurement clock period; T is the gate time; f_{in} is the frequency of the unknown signal; E_{npk} equals peak noise pulse amplitude as presented to Schmitt trigger circuit; dv/dt equals signal slope at input to Schmitt trigger (volts per second). These formulas were used to develop the associated charts.

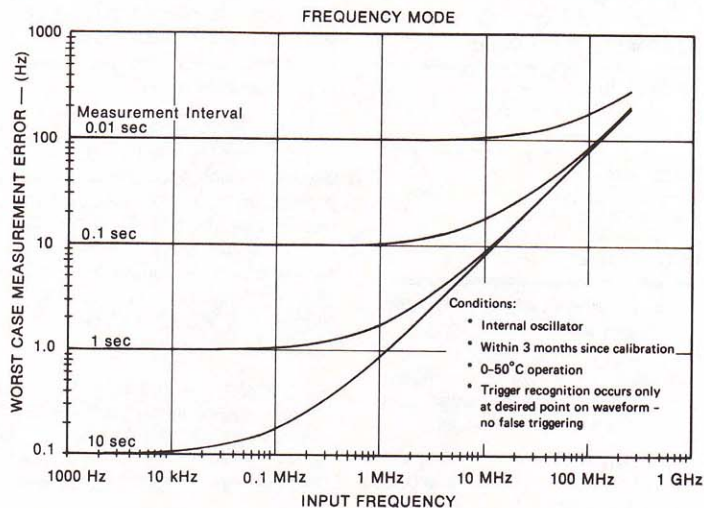

The 7D15 has high resolution because of a 10 ns clock, one of five clock positions obtainable from the front panel. A front panel Clock Out connector makes the selected clock signal available at a front-panel connector. This provides a time mark function that is TTL compatible and will drive a 50 Ω load.

The Ext Clock in connector allows an external 1 MHz timing standard to be used for measurements requiring a higher degree of accuracy than that provided by the internal time base.

The 7D15 may be used in vertical or horizontal compartments of 7000 Series Mainframes. It provides a full 8 digit CRT display with leading zero suppression and positioned decimal. Legend and averaging information appear at the bottom of the CRT display.

ACCURACY

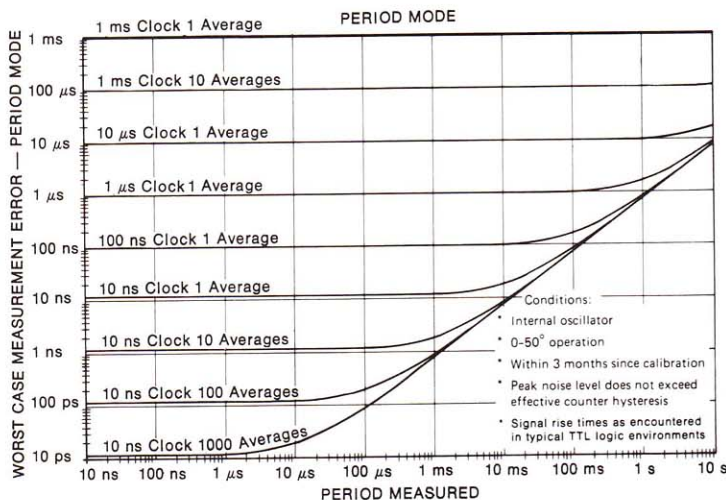
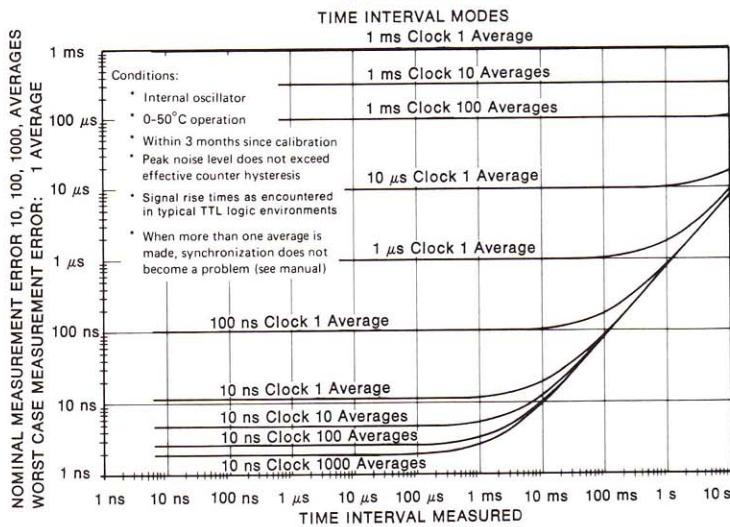

INTERNAL TIME BASE

Crystal Oscillator — Accuracy: within 0.5 ppm (0°C to +50°C ambient). Long-term drift: 1 part or less in 10⁷ per month. Oscillator is temperature compensated; no warm up is required.

OUTPUT SIGNALS

Clock Out — Logical 1 \geq +0.5 V into 50 Ω . Logical 0 \leq 0 V into 50 Ω . TTL compatible without 50 Ω load (1.6 mA current capacity).

A and B Trigger Level — $Z_{out} \approx$ 1 k Ω , $V_{out} = \pm 0.5$ V into 1 M Ω .

Displayed Waveform (Internally Connected) — Front-panel switch selects true gate, pseudo gate, or channel B signal out. Position controlled by front-panel screwdriver control.

External Display — Same as internal except position control has no effect.

Display Mode Switch — 0.1 to 5 s; also a preset position for infinite display time. Allows selection of readout "follow or store."

Readout — Eight-digit display; the four most significant have zero suppression. Overflow indicated by a greater than symbol.

INPUT SIGNAL CH A & B

Frequency Range (Ch B only) — Dc-coupled: dc to 225 MHz. Ac-coupled: 5 Hz to 225 MHz.

Sensitivity (Ch A and B Inputs) — 100 mV p-p. Trigger source: 0.5 division to 100 MHz, 1.0 division to 225 MHz, or to the vertical system bandwidth, whichever is less.

Input R and C — 1 M Ω and 22 pF.

Triggering (Preset Position) — Automatically triggers at 0 V.

Level Control Range (Ch A and B Inputs) — 100 mV range: ± 500 mV. 1-V range: ± 5 V. 10-V range: ± 50 V.

Arming Inputs — Input R and C: 10 k Ω and 20 pF. Sensitivity arm A: logical 1 \geq +0.5 V, logical 0 \leq +0.2 V. Sensitivity arm B: logical 1 \leq +0.2 V, logical 0 \geq +0.5 V.

External Clock-In — 20 Hz to 5 MHz.

Reset Front Panel — Reset readies the instrument. All counters are affected, including averaging circuits.

Included Accessories — Two cables RF 44 in (012-0403-00, Sealectro to BNC connector).

Order 7D15 Universal Counter/Timer \$2840

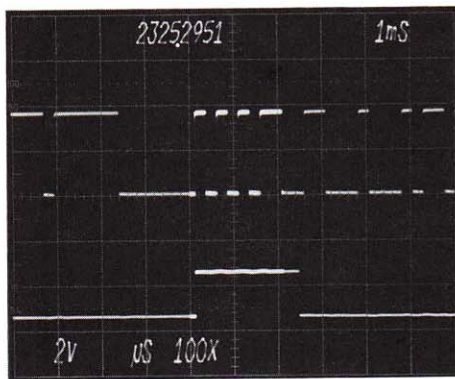

figure 1. Oscilloscope-controlled digital measurements using the delayed B gate as the arming input logic allow user to make precise *time interval measurement* from third to seventh pulse on CRT display. Counter Ch A is "armed" with leading edge of B gate while Ch B Counter is "armed" with falling edge of B gate. Lower trace is pseudo gate of 7D15. CRT readout displays the result of 2325.295 μ s.

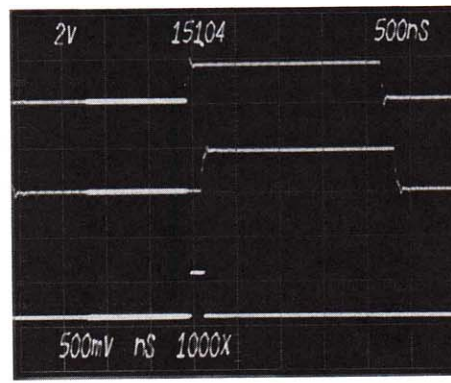

figure 2. The *propagation delay time* between the input of a delay line (upper trace) and the output of the delay line (middle trace) is measured digitally. Lower trace is 7D15 pseudo gate display. CRT readout displays the result of 151.0 ns.

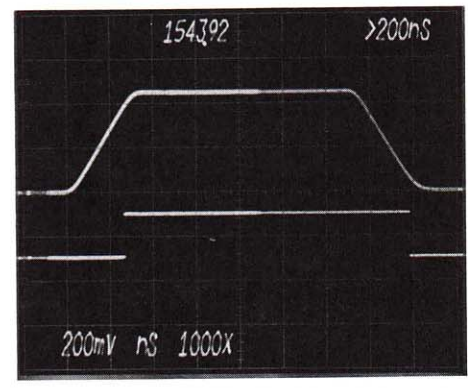

figure 3. Independent slope and level control allows the user to *visually select precise points* on the waveform where the counter starts and stops. CRT readout displays the result of 1543.9 ns.

**7D12/M2 A/D Converter
and Sample/Hold Module**

Automatic, Manual, or External Triggering

**Automatic Polarity and Overrange
Indicators**

Oscilloscope-controlled Sampling DVM

10 ns Aperture Uncertainty

**Input Signal and Sample Points
Displayed on CRT**

3 1/2 Digit CRT Readout

1 mV Resolution

25 MHz Bandwidth

**0-to-2 V and 0-to-20 V Input Range, 200 V
with P6055 Probe**

7D12/M2

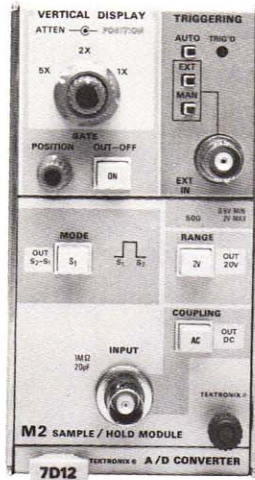

7D13A

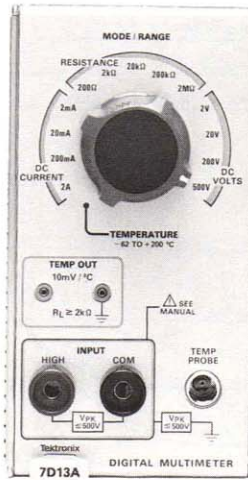

NEW

7D13A Digital Multimeter

Temperature Mode

500 V Max Common-mode Voltage

3 1/2 Digit CRT Readout

The 7D13A is a digital multimeter designed for use in all 7000 Series Oscilloscope Mainframes with CRT readout. The 7D13A functions in any compartment.

The 7D13A measures dc volts, dc current, and resistance. It also measures temperature from a temperature sensor on the tip of the P6601 temperature probe. The temperature probe functions regardless of 7D13A mode or range setting and provides a front-panel analog signal output of 10 mV/°C (0°C = 0 V). Temperature may be measured simultaneously along with any other function.

When the 7D13A is used, the character generator traces out a 3 1/2 digit display on the CRT and a legend for units like kΩ, mA, °C.

Dc Voltage Range — 0 to 500 V in four ranges. 3 1/2 digit presentation of 1.999 V, 19.99 V, 199.9 V, and 500 V full scale. Accuracy is ±0.1% of reading ±1 count from +15°C to +35°C, ±0.2% of reading ±2 counts from 0°C to +50°C. Input impedance is 10 MΩ on all ranges. Max safe input is 500 V peak between either contact and ground, 500 V peak between voltage contacts.

Dc Current Range — 0 to 2 A in four ranges. 3 1/2 digit presentation of 1.999 mA, 19.99 mA, 199.9 mA, and 1999 mA full scale. Accuracy is ±0.5% of reading ±2 counts from +15°C to +35°C, ±0.7% of reading ±4 counts from 0°C to +50°C. Max input is fuse protected.

Resistance Range — 0 to 2 MΩ in five ranges. 3 1/2-digit presentation 199.9 Ω, 1999 Ω, 19.99 kΩ, 199.9 kΩ, and 1999 kΩ full scale. Accuracy is ±0.5% of reading ±1 count from +15°C to +35°C, ±0.8% of reading ±2 counts from 0°C to +50°C. Input is fuse protected.

Temperature Measurement Range — -62° to +200°C in one range. 3 1/2 digit presentation to +200°C. Accuracy (+18°C to +28°C) is ±2°C from -62°C to +150°C and 0°C to -6°C from +150°C to 200°C with the probe calibrated to the instrument. Accuracy (0°C to +18°C and 28°C to +50°C) add 1.5°C to the above tolerance in each direction.

Settling Time — 1 s or less (voltage, current, and resistance modes).

Polarity — Automatic indication.

Max Common-Mode Voltage — 500 V peak between two terminals and ground.

Normal-mode Rejection Ratio — At least 30 dB at 60 Hz.

Common-mode Rejection Ratio — With a 1 kΩ imbalance, at least 100 dB at dc; 80 dB at 60 Hz.

Over Range Indication — When over range occurs, the readout blinks and the most significant digit displays a 3.

Temperature Out — 10 mV/°C into a load of at least 2 kΩ.

Included Accessories — P6601 Temperature Probe package (010-6601-01); pair of test leads (003-0120-00).

Order 7D13A Digital Multimeter \$1040

The 7D12 is designed for use with all 7000 Series Oscilloscope Mainframes with CRT readout.

The M2 Sample/Hold Module measures voltage amplitude from ground to a selected point or the difference voltage between any two selected points (independent control of each point). The sample point(s) may be triggered automatically, manually, or externally from sources such as the oscilloscope's Delayed B gate, the 7D15's pseudo gate, 7D11's delayed trigger out, etc.

On command, the 7D12/M2 samples the displayed waveform and also generates a gate display. Both the signal and 7D12/M2 gate are displayed together, providing a visual indication of where the sample(s) is taken. In the S₁ mode (sample one), a single sample coincident with the rise of the 7D12/M2 displayed gate is taken, and the voltage amplitude, from the 0 V level, is digitally displayed on the CRT readout. In the S₂-S₁ mode (sample two minus sample one), two samples are taken, one at the rise and one at the fall of the 7D12/M2 displayed gate, and the voltage difference between these two points is digitally displayed on the CRT readout.

CHARACTERISTICS

Sample-gate Display Amplitude — 2 div, rise time and fall time 5 ns or less.

Analog-signal Display — Bandwidth is dc to 25 MHz (dc-coupling), 3.4 Hz to 25 MHz (ac-coupling). Vertical sensitivity is 100 mV/div to 5 V/div in 6 steps (1-2-5 sequence in combination with M2 range and 7D12 vertical display attenuation). Accuracy is within 5%.

Input R and C — 1 MΩ and 20 pF.

Max Input Voltage — 100 V peak.

Measurement Readout — 0 to 20 V in two ranges. 3 1/2-digit presentation of 1.999 V and 19.99 V full scale, extended to 199.9 V with P6055 Probe.

Overrange indication — When overrange occurs, a > symbol appears to the left of the reading.

Aperture Uncertainty — 10 ns or less.

Pulse-width Sample Time (S₂-S₁ mode) — 30 ns to 5 ms with repetitive signal. 150 μs to 5 ms with single-shot signal.

Measurement Rate — External Trigger: 1 to 12 measurements per second, depending on external trigger frequency and internal adjustment. Auto Trigger: 1 to 4 measurements per second, internally adjustable.

Settling Time — 40 ns.

Accuracy without Probe (40 ns after Input Signal Step Function)

| Temperature Range | S ₁ Mode | S ₂ -S ₁ Mode |
|-------------------|---|--|
| +20°C to +30°C | ±0.15% of p-p input voltage, ±0.1% of reading, ±2 counts, ±% of ac decay* | ±0.25% of p-p input voltage, ±0.15% of reading, ±2 counts, ±% of ac decay* |
| +15°C to +40°C | ±0.25% of p-p input voltage, ±0.2% of reading, ±3 counts, ±% of ac decay* | ±0.35% of p-p input voltage, ±0.25% of reading, ±3 counts, ±% of ac decay* |

*Applicable when M2 is ac-coupled.

Included Accessory — 3.5 ft P6055 Probe package (010-6055-01).

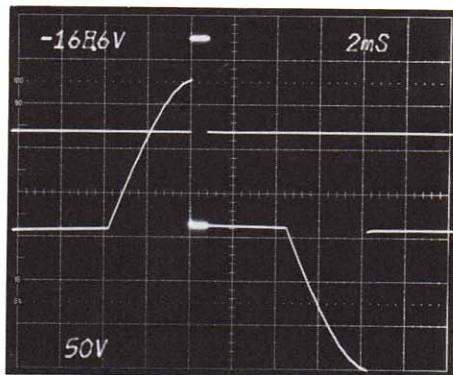

Sample and Hold DVM measures difference voltage (-168.6 V) between two points on complex waveform. Gate waveform indicates two points: leading and trailing edges where voltage difference is made.

ORDERING INFORMATION

| | |
|---|------------------|
| 7D12 A/D Converter (Module not included) | \$1410 |
| M2 Sample/Hold Module | \$1230 |
| Option 02 without P6055 | Sub \$120 |

7S11



7T11



7M11

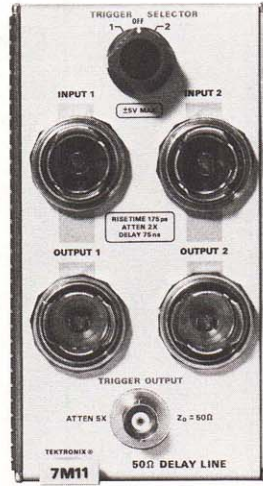

7S11

2mV/div to 200 mV/div
Calibrated Deflection Factors

Plug-in Sampling Heads

The 7S11 is a single-channel sampling unit. The input configuration employs the sampling plug-in head concept. The heads, which mount in the 7S11, range in bandwidth from 350 MHz to 14 GHz.

The 7S11 can be used in a variety of combinations. Single-channel sampling uses one 7S11 with a 7T11 Time Base. Two 7S11s and one 7T11 provide dual-trace sampling. One 7S11 and one 7S12 provide dual-trace sampling. Two 7S11s can be used for X-Y operations.

CHARACTERISTICS

Deflection Factor — 2 units/div to 200 units/div in 7 steps (1-2-5 sequence), accurate within 3%. Uncalibrated VARIABLE is continuous (extends deflection factor from 1 unit/div or less to at least 400 units/div). Deflection factor is determined by the plug-in sampling head.

Bandwidth — Determined by the sampling head.

Input Impedance — Determined by the sampling head.

Dc Offset — Range, +1 V to -1 V or more. Offset out is 10X the offset voltage within 2%. Source R is 10 kΩ within 1%.

Delay Range — At least 10 ns for comparing two signals in a dual-trace application.

Memory Slash — 0.1 div or less at 20 Hz.

Vertical Signal Out — 200 mV per displayed div within 3%.

Ambient Temperature — Performance characteristics are valid over an ambient temperature range of 0°C to +50°C.

Order 7S11 Sampling Unit without Sampling Head \$1670

7T11

10 ps/div to 5 ms/div Calibrated Time Base

Random or Sequential Sampling

Equivalent or Real Time Sampling

No Pretrigger Required

The 7T11 Sampling Time Base provides equivalent-time and real-time horizontal deflection for single- or dual-trace sampling. Timing accuracy is within 3% and nonlinearity is well below 1%. Triggering range is from ≈10 Hz (sequential mode) to above 12.4 GHz.

CHARACTERISTICS

Time/Div Range — 10 ps/div to 5 ms/div (1-2-5 sequence) directly related to time position ranges. Uncalibrated VARIABLE is continuous between steps to at least 4 ps/div.

Time Position Range — Equivalent time is 50 ns to 50 μs in 4 steps; real time is 0.5 ms to 50 ms in 3 steps.

Time/Div Accuracy — Within 3% for all time/div settings over center 8 cm.

TRIGGERING

Ext 50 Ω Input — Frequency range is dc to 1 GHz in 1X TRIG AMP mode. Sensitivity range is 12.5 mV to 2 V p-p (dc to 1 GHz) in X1 TRIG AMP, 1.25 mV to 2 V p-p (1 kHz to 50 MHz) in X10 TRIG AMP. Input R is 50 Ω within 10%. Max input voltage is 2 V (dc + peak ac).

Ext 1 MΩ Input — Frequency range is dc to 100 MHz in X1 TRIG AMP mode. Sensitivity range is 12.5 mV to 2 V p-p (dc to 100 MHz) in X1 TRIG AMP, 1.25 mV to 2 V p-p (1 kHz to 50 MHz) in X10 TRIG AMP. Input R is 1 MΩ within 5%. Max input voltage is 100 V p-p to 1 kHz (derating 6 dB per octave to a min 5 V p-p).

Ext Hf Sync — Frequency range is 1 GHz to 12.4 GHz. Sensitivity range is 10 mV to 500 mV p-p. Input R is 1 MΩ. Max input voltage is 2 V p-p.

Int Trigger Source (Sinewave Triggering)* — Frequency range is 5 kHz to 500 MHz in X1 TRIG AMP; 5 kHz to 50 MHz in X10 TRIG AMP. Sensitivity range is 125 mV to 1 V p-p (referred to the vertical input) in X1 TRIG AMP; 12.5 mV to 1 V p-p (referred to the vertical input) in the X10 TRIG AMP.

*Trigger circuits will operate to dc with pulse triggering, except for Hf Sync.

Random Mode Trigger Rate — 100 Hz min.

Display Jitter — Measured under optimum trigger conditions with TIME/DIV switch clockwise.

| Time Pos Range | Sequential Mode | Random Mode |
|-----------------|-----------------|---------------|
| 50 μs to 500 ns | 0.4 div or less | 1 div or less |
| | 50 ns | 10 ps |
| | | 30 ps |

Pulse Out — Positive pulse amplitude at least 400 mV (into 50 Ω) with 2.5 ns rise time or less.

Trigger Kickout — 2 mV or less into 50 Ω (except HF SYNC).

Display Scan Rate — Continuously selectable from at least 40 sweeps/s to <2 sweeps/s.

External Scan — Deflection factor is continuously variable from 1 V/div to 10 V/div. Input R is 100 kΩ within 10%. Max input voltage is 100 V (dc + peak ac).

Sweep Out — 1 V/div within 2%. Source R is 10 kΩ within 1%.

Ambient Temperature — Performance characteristics are valid over an ambient temperature range of 0°C to +50°C.

INCLUDED ACCESSORIES

42 in BNC 50 Ω cable (012-0057-01); 10X 50 Ω attenuator (011-0059-02); SMA (3 mm) male to BNC adapter (015-1018-00); SMA (3 mm) male to GR874 adapter (015-1007-00).

Order 7T11 Sampling Sweep Unit \$4185

7M11

75 ns Time Delay

Selectable Trigger Out

175 ps Rise Time

The 7M11 is a passive dual delay line unit for use with the 7000 Series Sampling System. In low-repetition-rate applications requiring the sequential mode of operation, the 7M11 provides the trigger source and signal delay necessary to view the triggering event at fast time-per-div settings.

Vertical delay for two 7S11 vertical sampling units is available with the dual 50 Ω, 75 ns delay lines. The closely matched (30 ps) lines have GR874 input-output connectors, 175 ps rise time, and 2X signal attenuation. Trigger selection is from either input, 5X attenuated, with a rise time of 600 ps or less.

CHARACTERISTICS

DELAY LINE

Time Delay — 75 ns within 1 ns.

Delay Difference — 30 ps or less between channels.

Rise Time — 175 ps or less.

Attenuation — 2X within 2% into 50 Ω.

Input Impedance — 50 Ω within 2%.

Max Input — ±5 V (dc + peak ac).

TRIGGER OUTPUT

Rise Time — 600 ps or less.

Attenuation — 5X within 10% into 50 Ω (referred to INPUT).

Output Impedance — 50 Ω within 10%

Ambient Temperature — Performance characteristics are valid over an ambient temperature range of 0°C to +50°C.

INCLUDED ACCESSORIES

10 in BNC cable (012-0208-00); two 2 ns GR cables (017-0505-00).

Order 7M11 Delay Line Unit \$1250

7S12

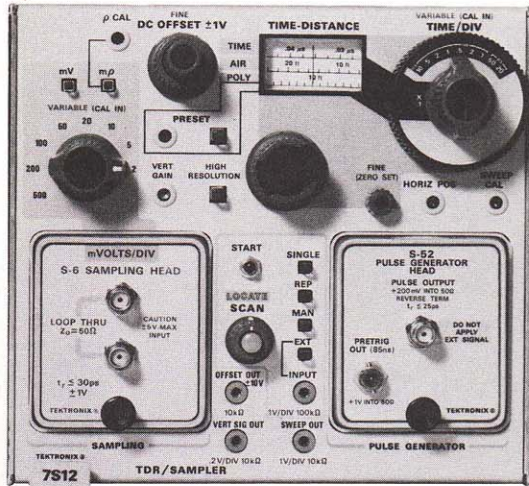

7S12

45 ps TDR or a General-purpose Sampler

6 Plug-in Sampling Heads Available

2 Plug-in Pulse Sources Available

1 Trigger Recognizer Head Available

1 Trigger Countdown Head Available

The 7S12 is a combined vertical-horizontal, double-width plug-in for high resolution TDR or general purpose sampling measurements. As a TDR using the S-6 Sampling Head and S-52 Pulse Generator Head, the 7S12 has a system rise time of 45 ps (return from short-circuit termination) and distance range to 290 feet in any cable. Its vertical scale is calibrated in reflection coefficient (ρ) from 2 m ρ /div to 500 m ρ /div and in voltage from 2 mV/div to 500 mV/div. Two-way time or one-way distance to a discontinuity of interest is read directly from tape dial calibrated for time, air, polyethylene, or your choice of dielectrics. As a long line TDR using the S-5 Sampling Head and S-54 Pulse Generator Head, distance calibration extends to 4900 ft (air line) and discontinuities to twice this distance may be viewed. System rise time with this combination is 1.5 ns.

General-purpose measurements may be made by using an S-1, S-2, S-3A, S-4, S-5, or S-6 Sampling Head with an S-53 Trigger Recognizer Head or S-51 Trigger Countdown Head. For dual-trace sampling displays, use a 7S11 Sampling Unit with a 7S12. The addition of a 7M11 Dual Delay Line provides the signal delay necessary to view the triggering event when a pretrigger signal is not available.

CHARACTERISTICS

SYSTEM PERFORMANCE WITH S-6 AND S-52

System Rise Time — 35 ps or less for the incident step. 45 ps or less for the displayed reflection from a short-circuited, 1 ns test line.

Time and Distance Ranges — Direct-reading tape dial gives calibrated one-way distance to at least 400 ft (air line). Time range is at least 0.9 μ s round trip. Both ranges are limited by the duration of the pulse from the S-52.

Pulse Amplitude — At least +200 mV into 50 Ω .

Input Characteristics — Nominal 50 Ω , feed-through signal channel (termination supplied). SMA (3 mm) connectors.

Jitter — <10 ps (without signal averaging).

Aberrations — +7%, -7%, total of 10% p-p within 1.8 ns of step with reference point at 1.8 ns from step; +2%, -2%, total of 4% p-p after first 2.5 ns with reference point at 300 ns from step.

TDR SYSTEM PERFORMANCE WITH S-5 AND S-54

System Rise Time — 1.5 ns or less for the displayed reflection from a short-circuited test line.

Time and Distance Ranges — Direct-reading tape dial gives calibrated one-way distances to 4900 ft air line, 3240 ft solid polyethylene. Time range is 20 μ s round trip.

Pulse Amplitude — At least +400 mV into 50 Ω .

Input Characteristics — Nominal 50 Ω test line connection (cable and T supplied). BNC connectors.

Jitter — <20 ps (without signal averaging).

Aberrations — +4%, -6%, total of 10% p-p within first 17 ns of step; +1.5%, -1.5%, total of 3% thereafter.

OTHER 7S12 CHARACTERISTICS

Vertical Scale — Calibrated in m ρ (reflection coefficient 10⁻³) and mV from 2 to 500 units/div in 8 steps (1-2-5 sequence), accurate within 3%. Uncalibrated VARIABLE is continuous between steps.

Resolution — Reflection coefficients as low as 0.001 may be observed. Signal averaging reduces test-line noise in display.

Dc Offset Range — +1 V to -1 V. Allows open-circuit reflections to be displayed at full sensitivity. Monitor jack provides X 10 dc offset through 10 k Ω .

Time/Distance — Tape dial is calibrated in time and distance: full-scale ranges of 4900 ft, 490 ft, 49 ft (air dielectric); 3200 ft, 320 ft, 32 ft (polyethylene dielectric); and 10 μ s, 1 μ s, 0.1 μ s (time). Accurate within 1%. Distance calibration may be preset for dielectric having propagation factors from 0.6 to 1.

Time/Div — 20 ps/div to 1 μ s/div (1-2-5 sequence) in three ranges with direct-reading magnifier. Accurate within 3%. Uncalibrated variable is continuous between steps.

Locate Button — Provides instant return to unmagnified display showing entire full-scale range. Brightened portion of trace indicates time position and duration of magnified display.

COMPARISON OF SAMPLING FEATURES

| | 7S11/7T11 | 7S12 | 7S14 |
|----------------------------|--|--|----------------------|
| Maximum Bandwidth | 14 GHz | 14 GHz | 1 GHz |
| Fastest Rise Time | <25 ps | <25 ps | <350 ps |
| Vertical Sensitivity Range | 2-200 mV/div | 2-500 mV/div | 2-500 mV/div |
| Sequential Equiv. Sampling | YES | YES | YES |
| Random Equiv. Sampling | YES | NO | NO |
| Real Time Sampling | YES | NO | NO |
| Smoothing | YES | YES | YES |
| Channels | 1 (2 with an additional 7S11.) | 1 (2 with an additional 7S11.) | 2 |
| TDR | NO (but can be done) | YES | NO (but can be done) |
| Changeable Heads | YES (vertical only) | YES (horizontal and vertical) | NO |
| Input Impedance | 50 or 1 M Ω (depending on head) | 50 or 1 M Ω (depending on head) | 50 Ω |

Display Modes — Repetitive or single sweep, manual or external scan.

Signal Outputs — Pin jacks provide both vertical signal and sweep outputs.

INCLUDED ACCESSORIES

750 ps rigid "U" delay line (015-1017-01); short-circuit termination (015-1021-00); TDR slide rule (003-0700-00).

ORDERING INFORMATION

7S12 TDR Sampling Unit

(tape dial in feet) without Sampling Heads \$3100

Option 03 Tape Dial Change (Meters) Add \$25

OPTIONAL ACCESSORIES

Patch Cords — Available for the OFFSET OUT, EXT SWEEP INPUT, VERT SIG OUT, and SWEEP OUT jacks of the 7S12. Pin-jack to pin-jack, 0.08 in dia. pin.

Red, 8 in, Order 012-0179-00 \$3.50

Red, 18 in, Order 012-0180-00 \$3.50

Black, 8 in, Order 012-0181-00 \$3.50

Black, 18 in, Order 012-0182-00 \$3.50

Tape Dial (Calibrated in ft)

Order 331-0273-00 \$28.00

Tape Dial (Calibrated in Meters)

Order 331-0276-00 \$28.00

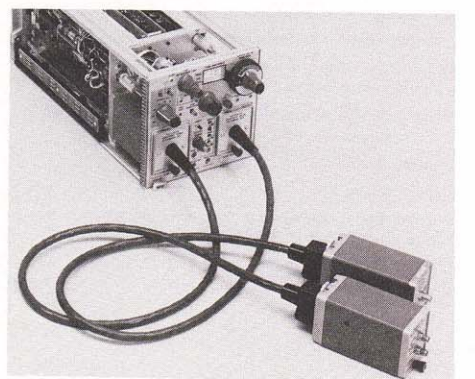

3 ft Sampling-Head Extender, Order 012-0124-00 \$345

6 ft Sampling-Head Extender, Order 012-0125-00 \$405

NOTE: See 1502-1503 Portable TDR Cable Tester on pages 116-117.

7S14

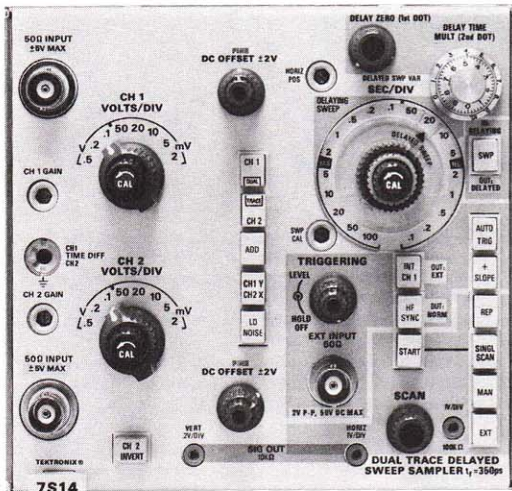

7S14

- Calibrated Delayed Sweep
- Two-dot Measurements
- Dc to 1 GHz Bandwidth
- Dual Trace, 2 mV Sensitivity
- CRT Readout
- Simplified Triggering
- Operational Ease of a Conventional Oscilloscope

The 7S14 Sampling Unit combines vertical and time-base functions in one double-width plug-in.

Two identical vertical channels provide dual-trace sampling, a two-ramp time base and calibrated delayed sweep.

Front-panel controls are grouped by color, and the control nomenclature is similar to conventional oscilloscope nomenclature. Learning to operate the 7S14 requires a minimum of effort for those familiar with conventional oscilloscope operation.

VERTICAL CHANNEL

Modes — Ch 1 only; Ch 2 only; Dual Trace; Ch 1 added to Ch 2; Ch 2 subtracted from Ch 1 (Ch 2 INVERT); Ch 1 Vertical (Y), Ch 2 Horizontal (X).

Input Impedance — Nominally 50 Ω .

Bandwidth — Equivalent to dc to 1 GHz.

Rise Time — 350 ps or less.

Step Aberrations — +2%, -4%, total of 6% p-p within first 5 ns, $\pm 1\%$ thereafter, tested with a 284 Pulse Generator.

Deflection Factor — 2 mV/div to 0.5 V/div in 8 steps (1-2-5 sequence). Continuously variable between steps by at least 2.5 to 1.

Accuracy — Within $\pm 3\%$.

Max Input Voltage — ± 5 V.

Input Signal Range — 2 V p-p max within a +2 V to -2 V window at any sensitivity.

Dc Offset Range — At least +2 V to -2 V.

Displayed Noise — 2 mV or less unsmoothed (measured tangentially). Low noise pushbutton reduces random noise by a factor of 4 to 1 or more.

Vertical Signal Output — 0.2 V/div of vertical deflection; 10 k Ω source resistance.

Channel Delay Difference — Adjustable to zero, or for any time difference up to at least 1 ns.

TIME BASE

Scan Modes — Repetitive, single, manual, or external.

Delaying Sweep — May be used as the CRT time base or as a delay generator for the delayed sweep. The sweep starts with minimum delay from the instant of trigger recognition. When the delaying sweep mode is selected for the time base, two bright dots in the trace, which may be positioned anywhere on the displayed waveform, are generated. The time between dots is equal to the reading on the Delay Time Multiplier dial multiplied by the time/div.

Delayed Sweep — This mode is used when the signal to be displayed occurs considerably later than the instant of trigger recognition or when the time must be 5 ns or less per div. The delayed sweep may be started with zero delay time with respect to the start of the delaying sweep. Or the start may be delayed by any time interval up to that represented by ten divisions of the delaying sweep selected.

Horizontal Signal Output — 1.0 V/div of horizontal deflection; 10 k Ω source resistance.

DELAYING SWEEP

Range — 10 ns/div to 100 μ s/div in 13 steps (1-2-5 sequence).

Accuracy — Within $\pm 3\%$, excluding first one-half div of displayed sweep.

Delayed Zero (1st Dot) — Adjustable to correspond to any instant within the time interval represented by the first 9 div of the delaying sweep selected.

Delay Time (2nd Dot) — Adjustable to any position of the time interval represented by 10 div of the delaying sweep selected.

Delay Accuracy — Within $\pm 1\%$ of 10 div when measurement is made within the last 9.5 div.

DELAYED SWEEP

Range — 100 ps/div to 100 μ s/div in 19 steps (1-2-5 sequence). Variable between steps by at least 2.5 to 1.

Accuracy — Within $\pm 3\%$ excluding first one-half div of displayed sweep.

Start Delay — Depends on the delaying sweep time selected and the setting of the Delay Time Multiplier dial. Adjustable from zero to any time interval up to that represented by 10 div of the delaying sweep selected. The delaying sweep start point corresponds to the position of the second bright dot.

Delay Jitter — $< 0.05\%$ of the time represented by 1 div of the delaying sweep selected.

TRIGGERING AND SYNC

Signal Sources — Internal from Ch 1 vertical input or external through front-panel connector.

External Triggering — Nominal 50 Ω input, ac coupled, 2 V p-p 50 V dc max. Trigger pulse amplitude 10 mV p-p or more with rise time of 1 μ s or less. 10 Hz to 100 MHz. Sinewave amplitude 10 mV p-p or more from 150 kHz to 100 MHz.

Internal Triggering — Pulse amplitude 50 mV p-p or more with rise time of 1 μ s or less. Sinewave amplitude 50 mV p-p or more from 150 kHz to 100 MHz.

Triggered Mode — Trigger recognition may be made to occur at any selected voltage level between +0.5 V and -0.5 V on either a + slope or a - slope of the triggering signal.

Auto Trigger Mode — For small signals or when there may be no triggering signal. Sampling pulses are automatically generated at a low rate in the absence of a triggering signal so that a trace may always be generated and displayed. The trigger level range automatically adjusts to approx the p-p voltage of the signal.

Holdoff — Varies the length of the interval during which recognition is inhibited. Variation is at least 5 to 1. The control is particularly useful for displaying digital words when triggering on binary pulses.

Hf SYNC Mode — For sinewaves from 100 MHz to 1 GHz, 10 mV p-p or more from external source, 50 mV p-p or more from internal pickoff.

Order 7S14 Dual-Trace Delayed Sweep Sampler \$4915

284



284

- 70 ps or Less Rise Time Pulse
- Sinewave and Squarewave Outputs

CHARACTERISTICS

OUTPUT

Pulse Output — 70 ps or less rise time with a pulse width of more than 1 μ s and a repetition rate of ≈ 50 kHz. Aberrations immediately following positive-going transitions are $< \pm 3\%$, 3% total p-p; after 2 ns $< \pm 2\%$, 2% total p-p. Pulse amplitude is more than +200 mV into 50 Ω . Source resistance is 50 Ω .

Squarewave Output — Periods of 10 μ s, 1 μ s, or 100 ns. Amplitude is 10 mV, 100 mV, or 1 V into 50 Ω .

Sinewave Output — Periods of 10 ns or 1 ns. Output amplitude is 100 mV into 50 Ω .

Trigger Output — Squarewave, sinewave, or pretrigger pulse output, depending on the selected main signal output. Amplitude is 200 mV, accurate within 40%. When PULSE OUTPUT is selected, the trigger can be switched to arrive 5 ns ± 5 ns, or 75 ns ± 5 ns ahead of the main pulse. Rise time is 3 ns or less; pulse width is 10 ns or greater.

Timing and Amplitude Accuracy

| Output | Period | Timing Accuracy | Amplitude Accuracy | | |
|-------------|------------|-----------------|--------------------|--------------|-------------|
| | | | 1 V | 100 mV | 10 mV |
| Pulse | 20 μ s | $\pm 10\%$ | | | |
| Square-wave | 10 μ s | $\pm 0.5\%$ | $\pm 0.5\%$ | $\pm 1\%$ | $\pm 1.5\%$ |
| | 1 μ s | $\pm 0.05\%*$ | $\pm 2\%†$ | $\pm 2.5\%†$ | $\pm 3\%†$ |
| Sine-wave | 10 ns | | | | |
| | 1 ns | $\pm 1\%$ | | $\pm 20\%$ | |

*crystal controlled † 20 ns after transition

Order 284 Pulse Generator \$3085

S-1

Dc to 1 GHz Bandwidth

Clean Transient Response

The S-1 Sampling Head is a low noise, 350 ps rise time unit with a 50 Ω input impedance. The S-1 can be plugged in or attached by a cable for remote use. A trigger pickoff within the S-1 provides a trigger signal output from the plug-in unit.

Rise Time — 350 ps or less.

Bandwidth — Equivalent to dc to 1 GHz at 3 dB down.

Transient Response — Aberrations as observed with the 284 Pulse Generator are +0.5%, -3% or less, total of 3.5% or less p-p, first 5 ns following the step transition; -0.5% or less, total of 1% or less p-p after 5 ns.

Displayed Noise — 2 mV or less, unsmoothed; 1 mV, smoothed.

Signal Range — Variable dc offset allows signals between +1 V and -1 V limits to be displayed at 2 mV/div. Signals between +2 V and -2 V limits may be displayed at 200 mV/div. For best dot response with random-sampling sweep unit, signal amplitude should be <500 mV p-p.

Input Characteristics — Nominally 50 Ω . Safe overload in \pm 5 V. GR874 input connectors.

Included Accessories — 5 ns, 50 Ω RG58 A/U cable (017-0512-00); 10X, 50 Ω GR attenuator (017-0078-00).

Order S-1 Sampling Head \$1090

S-2

Dc to 4.6 GHz Bandwidth

Displayed Noise <6 mV (Unsmoothed)

The S-2 Sampling Head is a 75 ps rise time unit with a 50 Ω input impedance. The S-2 can be plugged in or attached by a cable for remote use. A trigger pickoff within the S-2 provides a trigger signal output from the plug-in unit.

Rise Time — 75 ps or less.

Bandwidth — Equivalent to dc to 4.6 GHz at 3 dB down.

Transient Response — Aberrations as observed with the 284 Pulse Generator are +5%, -5% or less, total of 10% or less p-p, first 2.5 ns following a step transition; +2%, -2% or less total of 4% or less p-p after 2.5 ns.

Displayed Noise — 6 mV or less, unsmoothed; 3 mV, smoothed.

Signal Range — Variable dc offset allows signals between +1 V and -1 V limits to be displayed at 2 mV/div. Signals between +2 V and -2 V limits may be displayed at 200 mV/div. For best dot response with random-sampling sweep unit, signal amplitude should be <200 mV p-p.

Input Characteristics — Nominally 50 Ω . Safe overload is \pm 5 V. GR874 input connectors.

Included Accessories — 5 ns, 50 Ω RG213/U cable (017-0502-00); 10X, 50 Ω GR attenuator (017-0078-00).

Order S-2 Sampling Head \$1280

OPTIONAL ACCESSORIES

- P6040/CT-1 Current Probe, Order (Std) 015-0041-00 \$130
- P6056 10X Passive Probe, Order (Std) 010-6056-03 \$140
- P6057 100X Probe, Order (Std) 010-6057-03 \$145
- Coupling Capacitor, GR874-K, Order 017-0028-00 \$90
- Power Divider GR874-TPD, Order 017-0082-00 \$225
- GR to BNC Adapter, Order 017-0063-00 \$43



S-3A

Compact, 4.5 ft, 100 k Ω , 2.3 pF Probe

Dc to 1 GHz Bandwidth

Displayed Noise <3 mV (Unsmoothed)

The S-3A Sampling Head is an active sampling-probe unit with 100 k Ω , 2.3 pF input impedance. Up to 2 V of dc offset may be used while maintaining a 2 mV/div deflection factor.

Rise Time — 350 ps or less.

Bandwidth (Probe Only) — Equivalent to dc to 1 GHz at 3 dB down.

Transient Response (Probe Only) — Aberrations in the first 2 ns following a step are +8%, -2% or less, total of 10% or less p-p, +1%, -1% or less, total of 2% or less p-p after 2 ns, with 284 pulse displayed.

Displayed Noise (Probe Only) — 3 mV or less referred to probe tip (includes 90% of dots).

Signal Range — Variable dc offset allows signals between +1 V, 1X range, or +2 V and -2 V, 2X range, to be displayed at 2 mV/div. The signal range may be increased 10X or 100X with the probe attenuators.

Included Accessories — 10X attenuator head (010-0364-00); 100X attenuator head (010-0365-00); coupling capacitor (011-0098-00); probe tip (206-0114-00); tipground adapter (013-0085-00); two test-point jacks (131-0258-00); 5 1/2 in ground lead (175-1017-00); 12 1/2 in ground lead (175-1018-00); 3 in cable assembly (175-0249-00); three ground clips (344-0046-00); end cap (200-0834-00); two end caps (200-0835-00); probe holder (352-0090-00); retractable hook tip (013-0097-01); 50 Ω voltage pickoff (017-0077-01); carrying case (016-0121-01); 3 in elec lead (175-0849-00); 6 in elec lead (175-0849-00).

Order S-3A Sampling Head \$1670

S-4

25 ps Sampling Head

Dc to 14 GHz Equivalent Bandwidth

Displayed Noise <5 mV (Unsmoothed)

The S-4 Sampling Head is a 25 ps rise time unit with a 50 Ω input impedance. The S-4 can be plugged into the sampling unit or attached by a sampling head extender for remote use. A trigger pickoff within the S-4 provides a trigger signal output from the plug-in unit.

Rise Time — 25 ps or less.

Bandwidth — Equivalent to dc to 14 GHz at 3 dB down.

Transient Response — Aberrations in the first 400 ps following a step from an S-52 Pulse Generator Head are -10%, +10% or less, total of 20% or less p-p. From 400 ps to 25 ns following a step from a 284 Pulse Generator, -0%, +10% or less, total of 10% or less, p-p with 284 pulse displayed; after 25 ns, -2%, +2% or less, total of 4% or less p-p.

Displayed Noise — 5 mV or less, un-smoothed; 2.5 mV, smoothed (includes 90% of dots).

Signal Range — Variable dc offset allows signals between +1 V and -1 V limits to be displayed at 2 mV/div. For best dot-transient response with random-sampling sweep unit, signal amplitude should be less than 500 mV p-p.

Input Characteristics — Nominally 50 Ω . Safe overload \pm 5 V. SMA (3 mm) input connector.

Included Accessories — 2 ns cable with SMA connectors (015-1005-00); 10X 50 Ω SMA attenuator (015-1003-00); GR874 to SMA male adapter (015-1007-00); SMA male-to-male adapter (015-1011-00); 5/16 in wrench (003-0247-00).

Order S-4 Sampling Head \$2505

S-5

1 M Ω , 15 pF Input Impedance

Passive Probe

Internal Trigger Pickoff

The S-5 Sampling Head is a low-noise, 1 ns rise time sampling unit with a 1 M Ω , 15 pF input impedance. When used with the included P6010 Passive Probe, the input impedance increases to 10 M Ω , 10 pF while maintaining the 1 ns rise time at the probe tip. A switch on the sampling head selects either ac or dc coupling of the input.

Rise Time — S-5 only, 1 ns or less; with 3.5 ft P6010, 1 ns or less.

Bandwidth — Equivalent to dc to 350 MHz at 3 dB down at input connector or probe tip.

Transient Response — S-5 only (driven with a 50 Ω source terminated in 50 Ω); aberrations +2.5%, -5% or less, total of 7.5% or less p-p within 17 ns after step; +1%, -1% or less, total of 2% or less p-p thereafter.

S-5/P6010 (3.5 ft probe, properly compensated); aberrations +5%, -5% or less total of 10% or less p-p within 25 ns after step; +1%, -1% or less total of 2% or less p-p thereafter.

Displayed Noise — S-5 only, 500 μ V or less (includes 90% of dots). S5/P6010, 5 mV or less (includes 90% of dots).

Signal Range — S-5 only: dc coupled, 1 V p-p from +1 V to -1 V; ac coupled, 1 V p-p. S5/P6010: dc coupled (dc + peak ac), 10 V p-p; ac coupling, dc voltage, 100 V.

Input Characteristics — S-5 only, 1 M Ω within 1% paralleled by 15 pF. S-5/P6010, 10 M Ω paralleled by \approx 10 pF.

Attenuator Accuracy — Probe attenuation is 10X within 3%.

Included Accessories — P6010 Probe package (010-0188-00), 50 Ω termination (011-0049-01).

Order S-5 Sampling Head \$1160

OPTIONAL ACCESSORIES

- Probe Tip-to-BNC Adapter, Order 013-0084-01 \$8.00
- Probe Tip-to-GR Adapter, Order 017-0076-00 \$42
- Probe Tip-to-GR Terminated Adapter, Order 017-0088-00 \$44

SAMPLING HEAD CHARACTERISTICS

| | S-1 | S-2 | S-3A | S-4 | S-5 | S-6 |
|------------------------|---------------|--------------|--------------------------|---------------|--------------------|-----------------------|
| Bandwidth | Dc-1 GHz | Dc-4.6 GHz | Dc-1 GHz | Dc-14 GHz | Dc-350 MHz | Dc-11.5 GHz |
| Risetime | \leq 350 ps | \leq 75 ps | \leq 350 ps | \leq 25 ps | \leq 1 ns | \leq 30 ps |
| Input Impedance | 50 Ω | 50 Ω | 100 k Ω | 50 Ω | 1 M Ω | 50 Ω feed thru |
| Noise: Smoothed | \leq 1 mV | \leq 3 mV | — | \leq 2.5 mV | \leq 500 μ V | — |
| Unsmoothed | \leq 2 mV | \leq 6 mV | \leq 3 mV at probe tip | \leq 5 mV | \leq 5 mV | \leq 5 mV |
| Connector | GR | GR | Probe | SMA (3 mm) | BNC | SMA (3 mm) |

TIMING HEAD CHARACTERISTICS

| | S51 | S52 | S53 | S54 |
|--------------------|-------------------------------|---------------------|-----------------------------|-----------------------|
| Bandwidth | 1-18 GHz trigger countdown | — | Dc-1 GHz trigger recognizer | — |
| Risetime | — | \leq 25 ps | — | \leq 1 n |
| Application | extremely high speed sampling | high resolution TDR | general purpose sampling | medium resolution TDR |



S-6

30 ps Rise Time

Displayed Noise <5 mV (Unsmoothed)

Loop-through Input

The S-6 Sampling Head is a 50 Ω feed-through unit for high-speed applications.

Rise Time — 30 ps or less. 35 ps or less as observed with S-52 Pulse Generator.

Bandwidth — Equivalent to dc to 11.5 GHz at 3 dB down.

Transient Response — Pulse aberrations following the steps are +7%, -7%, total of 10% p-p within 1.8 ns of step with reference point at 1.8 ns from step; +2%, -2%, total of 4% p-p after first 2.5 ns with reference point at 300 ns from step.

Displayed Noise — 5 mV or less, measured tangentially.

Signal Range — +1 V to -1 V (dc + peak ac). 1 V p-p. Dc offset allows any portion of input signal to be displayed.

Input Characteristics — Nominally 50 Ω, loop-through system, unterminated. SMA (3 mm) connectors. Max safe overload is ±5 V.

Included Accessories — 50 Ω termination (015-1022-00); 1 ns 50 Ω cable (015-1019-00); SMA (3 mm) female-to-female adapter (015-1012-00); SMA male-to-GR874 adapter (015-1007-00); combination wrench (003-0247-00).

Order S-6 Sampling Head \$2160

OPTIONAL ACCESSORIES FOR SAMPLING HEADS with SMA (3 mm) Connectors

| | |
|---|---------|
| 2X 50 Ω Attenuator, Order 015-1001-00 | \$120 |
| 5X 50 Ω Attenuator, Order 015-1002-00 | \$120 |
| 10X 50 Ω Attenuator, Order 015-1003-00 | \$120 |
| 50 Ω Termination, Order 015-1004-00 | \$60 |
| 2 ns 50 Ω Signal Cable, Order 015-1005-00 | \$80 |
| 5 ns 50 Ω Signal Cable, Order 015-1006-00 | \$130 |
| Female-to-GR874 Adapter, Order 015-1007-00 | \$50 |
| Male-to-GR874 Adapter, Order 015-1008-00 | \$60 |
| Male-to-N Female Adapter, Order 015-1009-00 | \$50 |
| Male-to-7 mm Adapter, Order 015-1010-00 | \$175 |
| Male-to-Male Adapter, Order 015-1011-00 | \$20 |
| Female-to-Female Adapter, Order 015-1012-00 | \$16 |
| Coupling Capacitor, Order 015-1013-00 | \$170 |
| 50 Ω Power Divider T, Order 015-1014-00 | \$200 |
| 500 ps 50 Ω Semirigid Cable, Order 015-1015-00 | \$40 |
| SMA T Adapter, Order 015-1016-00 | \$30 |
| SMA Male-to-BNC Female Adapter, Order 015-1018-00 | \$8.00 |
| 1 ns 50 Ω Cable, Order 015-1019-00 | \$105 |
| SMA Male Short-Circuit Termination, Order 015-1020-00 | \$17.50 |
| SMA Female Short-Circuit Termination, Order 015-1021-00 | \$24 |
| SMA Male 50 Ω Termination, Order 015-1022-00 | \$32 |
| With BNC Connectors | |
| 50 Ω Feed-through Termination, Order 011-0049-01 | \$25 |
| 50 Ω Feed-through (5 W), Order 011-0099-00 | \$40 |
| 50 Ω 2X Attenuator, Order 011-0069-02 | \$35 |
| 50 Ω 2.5X Attenuator, Order 011-0076-02 | \$35 |
| 50 Ω 5X Attenuator, Order 011-0060-02 | \$35 |
| 50 Ω 10X Attenuator, Order 011-0059-02 | \$35 |
| 50 Ω 18 in, Coaxial Cable, Order 012-0076-02 | \$17 |
| 50 Ω 42 in, Coaxial Cable, Order 012-0057-01 | \$17 |

S-51

18 GHz Countdown

10 ps or Less Trigger Jitter

The S-51 Trigger Countdown Head is a free-running tunnel-diode oscillator designed to provide stable sampling displays of signals up to 18 GHz. The S-51 has a front-panel sync control that synchronizes the oscillator frequency to a subharmonic of the input signal. The output from the S-51 is available at a front-panel trigger output connector and through a rear-panel connector for internal triggering. The output signal is a direct countdown of the input and permits triggering by a standard sampling time-base unit.

Input Signal — Frequency range is 1 GHz to 18 GHz. Stable synchronization on signals at least 100 mV p-p, as measured separately into 50 Ω, 5 V, p-p max.

Input Characteristics — 50 Ω SMA (3 mm) connector. Open termination paralleled by 1 pF.

Trigger Output — Front-panel trigger output is at least 200 mV into 50 Ω, BSM type connector. Internal trigger output is at least 100 mV into 500 Ω, internally connected to sampling unit. Jitter is 10 ps or less with signals from 5 GHz to 18 GHz; 15 ps or less with signals from 1 GHz to 5 GHz. Kickout at signal input connector is 400 mV or less; kickout occurs between successive samples.

Order S-51 Trigger Countdown Head \$1225

S-52

25 ps Rise Time

200 mV into 50 Ω

50 Ω Source

Pretrigger Output

The S-52 Pulse Generator Head is a tunnel-diode step generator designed for use with the 7S12 as a high resolution Time Domain Reflectometer.

For tdr applications, the S-52 features automatic bias circuit control to eliminate effects of tunnel-diode and load changes. A 50 Ω reverse termination minimizes reflections. The pulse width is sufficient for distances up to 32 ft in any cable. A pretrigger output allows the S-52 to be operated in sequential sampling systems without a delay line.

Pulse Output — Rise time is 25 ps or less. Amplitude into 50 Ω is at least 200 mV, positive-going. Pulse duration 800 ns, pulse period 16 μs within 2 μs. Pulse aberrations following the step are +7%, -7%, total of 10% p-p within 1.8 ns of step with reference point at 1.8 ns from step, +2%, -2%, total of 4% p-p after first 2.5 ns with reference point at 300 ns from step.

Pretrigger Output — Rise time is 1 ns or less. Amplitude into 50 Ω is at least 1 V, positive going. Pretrigger pulse duration is 4 ns. Pretrigger occurs 85 ns (within 5 ns) before the pulse output. Pretrigger to pulse output jitter is 10 ps or less. Pretrigger output is also available at rear connector for internal triggering of the sampling sweep unit.

Output Connectors — Pulse output uses an SMA (3 mm) connector. Pretrigger output uses a BSM connector.

Included Accessory — 1 ns, 50Ω semirigid coax delay line (015-1023-00).

Order S-52 Pulse Generator Head \$1550

S-53

Dc-to-1 GHz Operation

10 mV Sensitivity

The S-53 Trigger Recognizer Head is intended for use with the 7S12 to permit operation as a general-purpose sampling system. The S-53 supplies triggering for the 7S12.

Input Characteristics — Frequency range is dc to 1 GHz. Sensitivity range is 10 mV to 2 V p-p into 50 Ω. Kickout at input, ±5 mV or less.

Output Characteristics — Rise time is 1 ns or less. Amplitude is at least 1.5 V positive-going into 50 Ω. Pulse duration is 3 ns within 2 ns at the 50% amplitude level. Pulse period is 27 μs minimum. Trigger-to-signal delay is 15 ns or less; jitter is 15 ps or less.

Connectors — Trigger input connector is BNC type. Front-panel trigger output connector is BSM type. Trigger output is also available at rear connector for internal triggering.

Included Accessories — 42 in, 50 Ω cable (012-0057-01); 10X 50 Ω attenuator (011-0059-02).

Order S-53 Trigger Recognizer Head \$1120

S-54

1 ns Rise Time

Low Aberrations

400 mV into 50 Ω

50 Ω Source

Variable Pretrigger Lead Time

The S-54 Pulse Generator Head is a step generator designed for use with the 7S12 as a long line Time Domain Reflectometer unit.

Intended for TDR applications, the S-54 is 50 Ω reverse terminated to minimize reflections and has a 0 V base line to eliminate base line shift with load changes. A continuously variable front-panel control enables adjustment of pretrigger lead time. The pretrigger output allows the S-54 to be operated in sequential sampling systems without a delay line.

Pulse Output — Rise time is 1 ns or less. Amplitude into 50 Ω is +400 mV or greater. Pulse duration is 25 μs within 2 μs. Pulse aberrations following the step are +1.5%, -1.5%, total of 1.5% p-p, as displayed with S-1 Sampling Head. Base line level is 0 V within 20 mV, terminated in 50 Ω.

Pretrigger Output — Rise time is 5 ns or less. Amplitude into 50 Ω is at least 200 mV, positive-going. Pretrigger pulse duration is 20 ns or less at the 50% amplitude point. Pretrigger lead time is front panel adjustable from 120 ns or less to 1 μs or greater. Pretrigger-to-pulse-output jitter is 100 ps or less at 120 ns lead time to 1 ns or less at 1 μs lead time.

Output Connectors — Pulse output uses a BNC connector. Pretrigger output uses a BSM connector.

Included Accessories — BNC T connector (103-0030-00); 8 in 50 Ω cable (012-0118-00).

Order S-54 Pulse Generator Head \$1010

SAMPLING HEAD WEIGHTS (Approx)

| | S-1 | | S-2 | | S-3A | | S-4 | | S-5 | |
|-----------------|-----|----|------|-----|------|-----|------|-----|------|-----|
| | kg | lb | kg | lb | kg | lb | kg | lb | kg | lb |
| Net | 0.5 | 1 | 0.5 | 1 | 1.4 | 3 | 0.5 | 1 | 0.3 | 0.6 |
| Shipping | 1.4 | 3 | 1.4 | 3 | 2.3 | 5 | 0.9 | 2 | 0.9 | 2 |
| | S-6 | | S-52 | | S-53 | | S-54 | | S-51 | |
| | kg | lb | kg | lb | kg | lb | kg | lb | kg | lb |
| Net | 0.5 | 1 | 0.3 | 0.8 | 0.3 | 0.8 | 0.3 | 0.8 | 0.5 | 1 |
| Shipping | 0.9 | 2 | 0.5 | 1 | 0.5 | 1 | 0.5 | 1 | 2.3 | 5 |

7CT1N

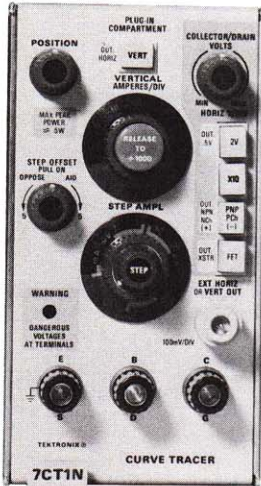

Curve Tracer

7CT1N

**10 nA/div to 20 mA/div
Vertical Deflection Factors**

**0.5 V/div to 20 V/div
Horizontal Deflection Factors**

The 7CT1N Curve Tracer Plug-in displays characteristic curves of small-signal semiconductor devices to power levels up to 0.5 W. The 7CT1N operates in horizontal or vertical compartments of 7000 Series Oscilloscopes.

CHARACTERISTICS

COLLECTOR/DRAIN SUPPLY

| | X1 | | X10 | |
|----------------------|-----------|----------|----------|-----------|
| Horizontal Volts/Div | 0.5 | 2 | 5 | 20 |
| Voltage Range | 0 - 7.5 V | 0 - 30 V | 0 - 75 V | 0 - 300 V |
| Max Current | 240 mA | 60 mA | 24 mA | 6 mA |

Max Open Circuit Voltage — Within $\pm 20\%$. Max short-circuit current, within 30%.

Series Resistance — Automatically selected with horizontal V/div switches. Peak power is 0.5 W or less, depending upon control settings.

High Voltage Warning — When the horizontal V/div switch is in the X10 position, a flashing warning light, indicating that dangerous voltages may exist at the test terminals, appears on the front panel.

STEP GENERATOR

Transistor Mode — Step amplitude range is 1 $\mu\text{A}/\text{step}$ to 1 mA/step, 1-2-5 sequence. Max current (steps plus aiding offset) is 15X amplitude setting. Max voltage (steps plus aiding offset) is at least 13 V. Max opposing offset current is at least 5X amplitude setting.

FET Mode — Step amplitude range is 1 mV/step to 1 V/step, 1-2-5 sequence. Voltage amplitude (steps plus aiding offset) is 15X amplitude setting, 13 V max. Source impedance is 1 k Ω \pm 1%.

Accuracy — Incremental: within 3% between steps. Absolute: within $\pm(3\% + 0.3X)$ amplitude setting).

Step Polarity — The step generator polarity is the same as the collector/drain supply in the transistor mode and opposing in the FET mode.

Number of Steps — Selectable in 1 step increments between 0 and 10.

Offset — Selectable to 5 steps. Polarity aids or opposes the step polarity.

Vertical Deflection Factors — 10 nA/div to 20 $\mu\text{A}/\text{div}$ with the $\div 1000$ control activated. 10 $\mu\text{A}/\text{div}$ to 20 mA/div in the 1X mode.

Vertical Display Accuracy — Within 5% in the 1X mode. Within 5% ± 0.2 nA per displayed horizontal volt in the $\div 1000$ mode.

Horizontal Deflection Factors — Selectable: 0.5 V, 2 V, 5 V, or 20 V.

Horizontal Display Accuracy — Within 5% plus the deflection factor accuracy of the plug-in being driven. The plug-in is a vertical or horizontal amplifier with a 100 mV/div deflection factor and an input R of at least 50 k Ω when it is used in the horizontal compartment.

Order 7CT1N Curve Tracer \$1305

7M13

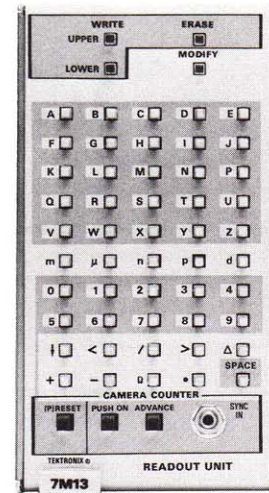

Readout Unit

7M13

Easy and Convenient Identification of Photographed Displays

Automatic Sequence Advance with Each Camera Exposure

The 7M13 Readout Unit provides front-panel keyboard operation for convenient access to the CRT readout characters. Up to ten alphanumeric characters can be displayed at the top and/or at the bottom of the CRT. The 7M13 is designed for use in all 7000 Series Mainframes with CRT readout. A remote-advance cable is supplied with the 7M13 to connect it to the shutter X-sync connector of the C-50 Series Cameras. An optional cable is available for cameras using an ASA connector for X-sync.

Included Accessory — Remote-advance cable (012-0339-01).
Order 7M13 Readout Unit \$880

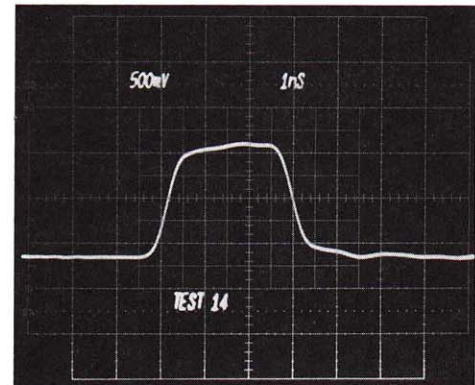

The photograph above was identified as TEST 14 by using the 7M13 in 7834 Oscilloscope.

Optional Accessory — Remote-advance cable with ASA connector for camera X-sync

Order 012-0364-01 \$20

5000 SERIES INSTRUMENTS

MAINFRAMES

| Mainframe/ Display Unit | Page | Beams | Storage | Display Size |
|-------------------------------|------|--------|-------------------------|-----------------------------|
| 5110 | 214 | Single | | 8 x 10 div (1.27 cm/div) |
| 5111 | 214 | Single | Bistable | 8 x 10 div (1.27 cm/div) |
| 5113 | 215 | Dual | Bistable | 8 x 10 div (1.27 cm/div) |
| 5115 | 215 | Single | Bistable | 8 x 10 div (1.22 cm/div) |
| 5223 | 208 | Single | Digital | 8 x 10 div (1.22 cm/div) |
| 5440 | 210 | Single | | 8 x 10 div (1.22 cm/div) |
| 5441 | 211 | Single | Variable Persistence | 8 x 10 div (0.9 cm/div) |

SPECIAL-PURPOSE PLUG-INS

| Product | Page | Description |
|---------|------|----------------------------------|
| 5CT1N | 221 | Semiconductor Curve Tracer |
| 5L4N | 221 | Low-Cost Spectrum Analyzer |
| 5S14N | 221 | Dual-Trace Delayed Sweep Sampler |
| 5D10 | 217 | Waveform Digitizer |

AMPLIFIERS

| Product | Page | Type | Minimum Deflection Factor | Band- width -3 dB | Cmrr |
|---------|------|---------------------------------------|---------------------------------|-------------------------|-----------|
| 5A13N | 218 | Single | 1 mV/div | 2 MHz | 10,000:1 |
| 5A14N | 216 | Four | 1 mV/div | 1 MHz | |
| 5A15N | 216 | Single | 1 mV/div | 2 MHz | |
| 5A18N | 217 | Dual | 1 mV/div | 2 MHz | |
| 5A19N | 218 | Single | 1 mV/div | 2 MHz | 1000:1 |
| 5A21N | 218 | Single (voltage and current) | 50 μ V/div 0.5 mA/div | 1 MHz | 100,000:1 |
| 5A22N | 219 | Single | 10 μ V | 1 MHz | 100,000:1 |
| 5A26 | 219 | Dual | 50 μ V/div | 1 MHz | 100,000:1 |
| 5A38 | 212 | Dual | 10 mV/div | 35 MHz | |
| 5A48 | 212 | Dual | 1 mV/div* | 50 MHz | |

*Bandwidth is dc to 25 MHz at 1 mV/div and 2 mV/div.

TIME-BASE PLUG-INS

| Product | Page | Type | Sweep Rate | Mag | Single Sweep | Volts/ Div Ext Mode |
|---------|------|-----------------------|--|-----|-----------------|---------------------------|
| 5B10N | 220 | | 1 μ s to 5 s | X10 | Yes | 50 mV and 500 mV |
| 5B12N | 220 | Dual Delay- ing | A 1 μ s to 5 s B 2 μ s to 0.5 s | X10 | Yes | 50 mV and 500 mV |
| 5B40 | 212 | | 0.1 μ s to 5 s | X10 | Yes | 50 mV |
| 5B42 | 213 | Delay- ing | A 0.1 μ s to 5 s B 0.1 μ s to 0.5 s | X10 | Yes | 50 mV |
| 5B25N | 213 | Digiti- zer | 0.2 μ s to 5 s | X10 | Yes | 50 mV |

Digital Storage Capability ... The 5223 Digitizing Oscilloscope provides digital storage at the touch of a button, intensified pre-trigger viewing, equivalent time sampling, and X-Y displays. This 5000 Series Scope, with optional IEEE-488 interface, is ideal for physical, mechanical and biomedical applications.

Performance Value ... The 5400 Series is designed for the cost-conscious user as an alternative to the monolithic scope; it gives you 50 MHz bandwidth in both non-store and variable persistence storage mainframes with CRT readout.

Maximum Flexibility ... The 5100 Series is ideal for low frequency applications such as medical and mechanical measurements requiring up to 2 MHz bandwidth; it gives you unparalleled choices in measurement flexibility such as dual-beam; split-screen, bistable storage displays, differential inputs and spectrum analysis.

Expandability ... With the 5000 Series Plug-in Oscilloscope, you are making a cost-

CONTENTS

Mainframes

| | |
|---|-----|
| 5223 10 MHz Digital Storage | 208 |
| 5440/R5440 50 MHz General Purpose | 210 |
| 5441/R5441 50 MHz Variable Persistence Storage | 211 |
| 5110 2 MHz Single Beam | 214 |
| 5111 2 MHz Single Beam Bistable Storage .. | 214 |
| 5113 2 MHz Dual Beam Bistable Storage ... | 215 |
| 5115 2 MHz Single Beam Bistable Storage .. | 215 |

Plug-Ins

| | |
|-----------------------------------|----------|
| Single Channel Amplifiers | 216 |
| Two Channel Amplifiers | 212, 217 |
| Four Channel Amplifier | 216 |
| Waveform Digitizer | 217 |
| Differential Amplifiers | 218 |
| Dual Differential Amplifier | 219 |
| Time Bases | 213, 220 |
| Curve Tracer | 221 |
| Spectrum Analyzer | 221 |
| Dual Trace Sampler | 221 |

effective investment in current technology —and insuring yourself a share in the future.

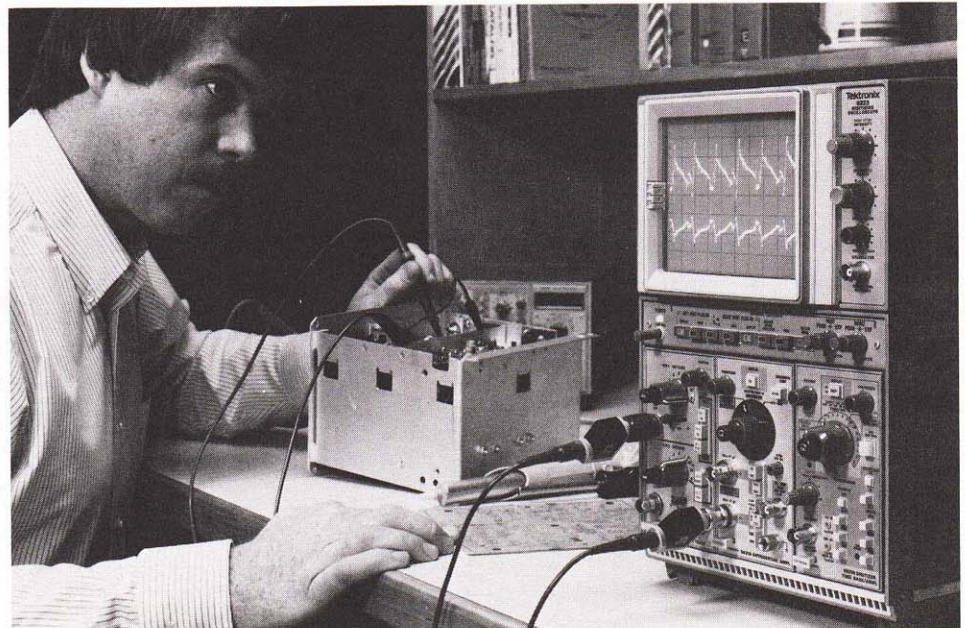

Low Cost

2 MHz, 10 MHz or 50 MHz Bandwidth

Sampling to 1 GHz

0 to 100 kHz Spectrum Analysis

6 Oscilloscope Models

21 Plug-ins Available

Digital, Dual-Beam and Storage Displays

CRT Readout (5400 Series only)

Large 6.5 inch CRT (8 x 10 div)

10 μ V/div High Gain Differential Amplifier

1 to 8 Trace Capability

Delayed-Sweep Time Bases

Y-T or X-Y Operation

Bench-to-Rack Convertibility

The 5000 Series Oscilloscopes are designed to provide optimum versatility and performance at the lowest possible price.

5100 SERIES OSCILLOSCOPES

Four 5100 Series Oscilloscopes are available. They include single-beam, dual-beam, and storage displays. The storage display units feature bistable, split-screen storage with large 6.5 inch

CRTs. The dual beam units, have two writing guns and two pairs of vertical deflection plates. One pair of horizontal deflection plates drives both beams.

The 5100 Series features 2 MHz mainframes with large 6.5 inch CRTs that accommodate two vertical deflection plug-ins and one horizontal deflection plug-in. They can be easily converted from bench to rackmount configuration.

To date, 15 plug-ins are available for use with the 5100 Series. Among these are the low-cost 5L4N Spectrum Analyzer for the 0-to-100 kHz frequency range the 5S14N, a general purpose, 1 GHz dual-trace sampling plug-in and the 5D10 Waveform Digitizer.

5223 DIGITIZING OSCILLOSCOPE

You can get the benefits of digital storage, along with the time-tested advantages of a conventional analog scope, in the 10 MHz 5223 Digitizing Oscilloscope. Combined in one powerful, convenient oscilloscope are pushbutton ease, high quality waveform display, pretrigger signal manipulation, and optional GPIB interface, plus real-time analog display capability.

Use the 5223 in the digital storage mode to capture repetitive events at speeds of up to 10 MHz or single-shot events at speeds of up to 100 kHz. The 5223's maximum sample rate is 1 MHz; storage capacity is 1024 bits per vertical compartment.

The digitized display will never fade or bloom, so you get more accurate measurements, more conveniently. High 10-bit vertical resolution gives you an accurate representation of your signals.

5400 SERIES OSCILLOSCOPES

Two 5400 Series display units are presently available: a single-beam, non-storage display and a variable persistence storage display. Both feature CRT readout of plug-in scale factors, 3 plug-in compartments and benchmount-to-rackmount convertibility.

The 5400 Series offers 50 MHz bandwidth and is capable of satisfying a wide range of measurement needs. It features readout of plug-in scale factors on the CRT (except with plug-ins having a suffix N: 5A22N, 5B10N, etc.). This feature, previously available only on more sophisticated oscilloscopes, allows you to make measurements more quickly and conveniently. The CRT readout can also be external accessed.

PLUG-IN VERSATILITY

21 plug-ins are now available in the 5000 Series Family. All these plug-ins are compatible with the 5400 Series, and all but six are compatible with 5100 Series Mainframes.

The amplifier plug-ins include single, dual, and four trace units, various differential amplifiers (including one with a current probe input), and a differential comparator amplifier. The time-base plug-ins include single, dual, delayed sweep units, and a digital time base.

Four special-purpose plug-ins are also available. The 5L4N is a spectrum analyzer for the 0-to-100 kHz frequency range. It has 10 Hz bandwidth resolution. The 5CT1N is a semiconductor curve-tracer plug-in. It allows characteristic curves of transistors, FETs, diodes and other semiconductor devices to be displayed on the CRT. The 5S14N, a general-purpose dual-trace, delayed sweep sampler, extends the bandwidth of the 5100, the 5400 Series, and the 5223 to 1 GHz at 2 mV sensitivity.

The 5D10 is a dual channel waveform digitizer with cursors, CRT scale factor readout, roll mode and plotter output.

Back-lighted knob skirts on the plug-ins provide scale-factor readout. The correct scale factor is automatically indicated when using the X10 magnifier and the recommended 1X and 10X probes. In addition, the 5400 Series automatically presents correct scale factors on the CRT when used with non-N suffix plug-ins. This feature helps reduce human errors and enables photographic recording of measurement conditions.

5000 Series Instruments—Physical Characteristics

| | 5223 | | | | 5100 and 5400 Series | | | | Plug-ins | | | |
|------------------------|-----------|-----------|-----------|-----------|----------------------|-----------|-----------|-----------|--------------|-----------|--------------|-----------|
| | Cabinet | | Rackmount | | Cabinet | | Rackmount | | Single Width | | Double Width | |
| | in | cm | in | cm | in | cm | in | cm | in | cm | in | cm |
| Height | 12.9 | 32.8 | 7 | 17.8 | 11.9 | 30.2 | 5.3 | 13.3 | 5.0 | 12.7 | 5.0 | 12.7 |
| Width | 8.4 | 21.4 | 19 | 48.3 | 8.4 | 21.3 | 19.0 | 48.3 | 2.6 | 6.6 | 5.2 | 13.2 |
| Length | 22.5 | 57.2 | 22.4 | 56.9 | 20.4 | 51.8 | 19.0 | 48.3 | 12.0 | 30.5 | 12.0 | 30.5 |
| Weight (approx) | lb | kg | lb | kg | lb | kg | lb | kg | lb | kg | lb | kg |
| Net | 37.25 | 16.9 | 42 | 19.1 | 23.0* | 10.4* | 24.0* | 10.9* | 2.8 | 1.3 | 5.8 | 2.6 |
| Shipping | 45 | 20.5 | 52 | 23.6 | 32.0* | 14.5* | 43.0* | 19.5* | 10.0 | 4.5 | 10.8 | 4.9 |

Recommended Probes for 5000 Series Amplifier Plug-ins

The following probes are recommended for general use with the listed amplifier plug-ins. These probes automatically program the knob-skirt readout and the CRT readout (available only in the 5400 Series) to indicate correct deflection factor. Probe packages include various tips, ground leads and accessories.

Probes are also available in different lengths, attenuation ratios, input loading and bandwidths. Special purpose probes, such as high voltage, FET and current probes are available for use with 5000 Series Amplifier Plug-ins. See Probe section for complete information.

| Amplifier Plug-ins | Voltage Probe | Attenuation | Standard Length | Features | Package Number |
|--------------------|---------------|-------------------|-----------------|---|--|
| 5A14N | P6060 | 10X | 6 ft | Full bw, low cost, (not compatible with CRT readout). | 010-6060-03 |
| 5A15N | P6062B | 1X/10X | 6 ft | Full bw, switchable attenuation, ground reference button. | 010-6062-13 |
| 5A18N | | | | | |
| 5A13N | P6062B | 1X/10X | 6 ft | Full bw, switchable attenuation, ground reference button. | 010-6062-13 |
| 5A21N* | P6101 | 1X | 2 m | Full bw, miniature. Modular construction simplifies repair. | 010-6101-03 |
| 5A22N | | | | | |
| 5A26 | P6055 | Adjustable to 10X | 3.5 ft | Adjustable attenuation. Will give up to 20,000; 1 CMRR when used in pairs. (5A21N, 5A22N and 5A26). | 010-6055-01 |
| 5A38 | P6105 | 10X | 2 m | Full bw, miniature. Modular construction simplifies repair. | 010-6105-03 |
| | 5A48 | P6062B | 1X/10X | 6 ft | Switchable attenuation (full bandwidth in the 10X position) ground reference button. |
| | | P6101 | 1X | 2 m | Miniature, modular (reduced bandwidth). |

*The 5A21N also provides direct access to current probe P6021. Order 5A21N, Option 01 for 5A21N Amplifier and Current Probe package. See pages 218-219 for complete information.

CARTS

SCOPE-MOBILE® Carts — For cabinet models, order TEK Lab Cart, Model 3.

CAMERAS

All 5100 Series — C-5C, suitable for repetitive or stored traces.

5100 Storage Instruments, 5440 (with P back), 5441 (with G back) — C-59, general purpose.

For full details see Camera section.

ACCESSORIES

Blank Plug-in Kit — (040-0818-03)

Blank Panel — (016-0195-02)

Viewing Hoods — (016-0154-00, or 016-0452-00 folding)

Protective Cover — (016-0544-00)

For full details see Accessories section.

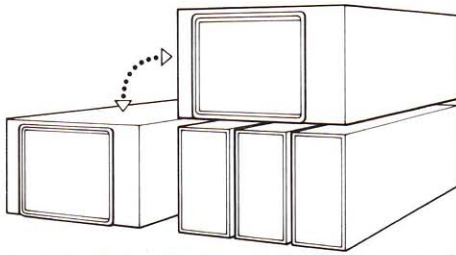

All 5000 Series Rackmount Oscilloscopes and cabinet-to-rackmount kits include complete slide out tracks and mounting hardware to interface with standard 19 inch racks.

CONVERSION KITS

- Cabinet-to-Rackmount, Order 040-0583-02 \$200
- Rackmount-to-Cabinet, Order 040-0584-03 \$125

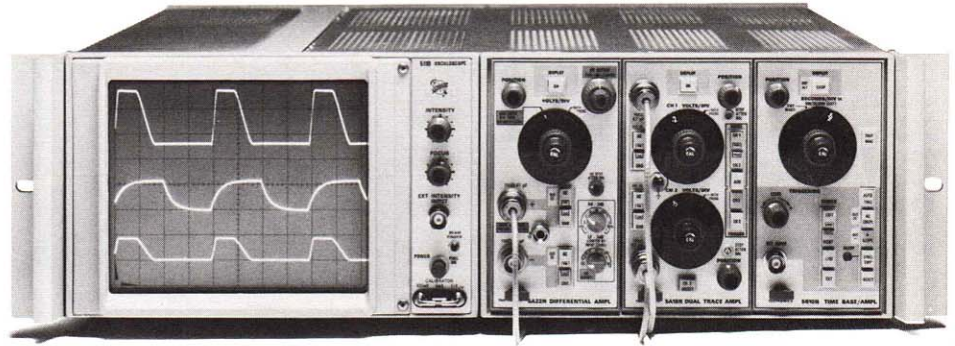

MECHANICAL MEASUREMENT TRANSDUCERS

| TRANSDUCER PACKAGE | DESCRIPTION | PERFORMANCE | RECOMMENDED ACCESSORIES |
|--------------------------------------|---|--|--|
| PRESSURE 015-0161-00* | RANGE: 3000 psig TYPE: Bonded Strain Gage 4 arm 350 Ω bridge Built-in CAL resistor | Accuracy: 1% Excitation: ≈10 Vdc Scale Factor: 3 mV/V f.s. f _c ≈65 kHz | 012-0209-00 20 ft multi-conductor cable |
| PRESSURE 015-0162-00* | RANGE: 300 psig TYPE: Bonded Strain Gage 4 arm 350 Ω bridge Built-in CAL resistor | Accuracy: 1% Excitation: ≈10 Vdc Scale Factor: 3 mV/V f.s. f _c ≈24 kHz | 012-0209-00 20 ft multi-conductor cable |
| PRESSURE (EAS) 015-0117-00 | RANGE: 3000 psig (dynamic only) TYPE: Piezoelectric | Accuracy: <5% Sensitivity: 200 pc/psi Max Overpressure: 300% Temp: -40°C to +150°C max | 015-0118-00 cooling adapter |
| ACCELERATION 015-0165-00 | RANGE: 0.001 to 1000 g's TYPE: Piezoelectric compression High capacitance (≈ 10,000 pF) NBS traceability | Accuracy: 5% Linearity: 2% Sensitivity: ≈12 mV/g f _c ≈30 kHz | 012-0211-00 microdot to BNC 20 ft cable |
| VIBRATION (EAS) 015-0116-00 | RANGE: 0.01 to 100 g's (100 to 10,000 RPM) TYPE: Piezoelectric magnetically mounted | Sensitivity: 6 mV/g (o.c.) Cr ≈3500 pF Temp: -40°C to +150°C f _c ≈11 kHz | 012-0137-00 BNC-BNC cable 50 ft |
| VERTICAL VIBRATION 015-0166-00 | TYPE: Seismic (geophone) Self generating SIGNALS: Velocity Displacement (integrated velocity) | Accuracy: <5% Scale Factor: Velocity ≈ 600 mV/in/s Displacement ≈ 10 mV/0.002 in Freq Range: 10 Hz to 2 kHz f _c ≈ 8 Hz Temp: -40°C to +71°C | 012-0136-00 BNC-BNC cable 20 ft long |
| HORIZONTAL VIBRATION 015-0167-00 | RANGE: 0.050 inch peak to peak | | |
| FORCE (Displacement) 015-0164-00* | RANGE: 50 grams 50 lbs (with load cell) 0.120 mm TYPE: Unbonded 350 Ω Strain Gage 4 arm bridge | Accuracy: 0.5% Excitation: ≈5 Vdc Full Scale Output: 80 to 80 mV Temp: -50°C to +85°C | Included with unit is 50 lb (22.5 kg) load cell, connected power cable, attachment bracket and tools |
| DISPLACEMENT 015-0168-00 | RANGE: ±4.0 mm (Calibrated and usable to ±0.2 inch) TYPE: Dc to dc LVDT | Accuracy: 2% linearity <1% Excitation: 3 to 11 Vdc Scale Factor: 1 V/mm at 8.5 Vdc 20 mV/0.001 inch at 7.5 Vdc Temp: -54°C to +80°C | 012-0209-00 20 ft cable |
| STRAIN 015-0171-00 | RANGE: 30,000 μ Strain TYPE: Foil Strain Gages 0.125 inch long. Attached leads. Package of five | Resistance: 120 Ω Gage Factor (Nominal) 2.1 Accuracy: 1% Excitation: (bridge), 5 V max | Strain Gage Adapter, 015-0169-00 Cement Kit 015-0172-00 |
| STRAIN GAGE ADAPTOR 015-0169-00* | Provides means for connecting 1, 2, or 4 arms of a Wheatstone Bridge to the Type PS 501-1 Mod 730E Transducer Power Supply. Has variable shunt resistor for gage factor calibration. The adaptor has four binding post terminals and a six-foot cable with 6-pin connector. | Accuracy: Governed by initial calibration and strain gages used. Strain Gage Resistance Range: 30 Ω to 5000 Ω for 4 arm bridges. 120 Ω for 1, 2 or 4 arm bridges. Bridge Volts: Typically 5 V for 120 Ω gages. Gage Factor Correction Range: 1.7 to 2.5 | Strain Gage Package, 015-0171-00 Cement Kit, 015-0172-00 |
| CEMENT KIT 015-0172-00 | Provides means for mounting and connecting foil strain gages. Includes Room Temperature Curing Epoxy cement, RTV Clear Silicon Rubber coating, Neoprene pads and metal plates, cementable Wiring terminals, and clear Mylar film. | | Strain Gage Package, 015-0171-00 |

- CABLE (012-0136-00)** \$70
20 ft low-noise coaxial cable with BNC connectors on both ends.
- CABLE (012-0209-00)** \$315
20 ft low-noise six-conductor cable with 6-pin connector on each end.
- CABLE (012-0210-00)** \$115
20 ft six-conductor cable with 6-pin male connector on one end.

- CABLE (012-0211-00)** \$35
20 ft low-noise coaxial cable with miniature coaxial connector on one end and BNC connector on the other.
- CONNECTOR (131-0618-00)** ... \$30
Mates Type PS501-1 Transducer Power Supply INPUT 6-pin connector.

TRANSDUCER PACKAGE PRICE LIST

| | |
|------------------------|------------------------|
| 015-0161-00 \$690 | 015-0167-00 \$450 |
| 015-0162-00 \$575 | 015-0164-00 \$750 |
| 015-0117-00 .. \$1625 | 015-0168-00 \$550 |
| 015-0165-00 \$390 | 015-0171-00 \$35 |
| 015-0116-00 .. \$1000 | 015-0169-00 \$375 |
| 015-0166-00 \$215 | 015-0172-00 \$95 |

APPLICATION NOTES

Following is a list of currently available Application Notes for 5000 Series Oscilloscopes.

| Title | Featuring | Part No. |
|---|---|-----------|
| STRUCTURAL TESTING The Digitizing Approach | 5223/5B25N/5A18N Single-shot techniques. Multi-trace using transducers. | AX-4461 |
| BIOPHYSICAL DATA RETRIEVAL The Digitizing Approach | 5223/5B25N/5A18N Roll mode, chart recorder output. | AX-4462 |
| RECORDING ELECTRO-PHYSIOLOGICAL NERVE ACTIVITY Using a plug-in oscilloscope | 5113/5A26/5A22N Low level measurements and storage. | AX-3746 |
| INTERPRETING MECHANICAL MEASUREMENTS With the plug-in oscilloscope | 5111/5A22N/5A18N Transducer measurements and storage. | AX-3533-1 |
| SIMULTANEOUS DISPLAY Of two independent X-Y signal pairs | 5111/5A15/5A15N/5A18N. Dual X-Y techniques, engine analysis. | AX-4114 |
| SIMULTANEOUS X-Y, Y-T DISPLAYS | 5111/5A15N/5A15N/5B12N. X-Y, Y-T techniques. Bio-medical application. | AX-4113 |
| CUSTOM PLUG-IN IDEAS For 5000 Series Scopes | Recommended starter note for customers considering custom plug-in project. | AX-3758 |
| A HIGH RESOLUTION 60 Hz notch filter | Construction project using a commercial module in our plug-in kit. Preconditions signals by removing 60 Hz hum. | AX-4031 |
| A TRUE RMS CONVERTER | Construction project using thermal true RMS converter module in our blank plug-in kit. Measures true RMS up to 200 V RMS. | AX-4112 |

*Requires PS 501-1 custom modified Transducer Power Supply mounted in a TM 500 Series Mainframe. Consult a Tektronix Sales Engineer for price and installation information on power supply and adapter.

5223

GPIB
IEEE-488

The 5223 complies with IEEE Standard 488-1978, and with Tektronix *Codes and Formats* Standard.

Digital Storage (with 5B25N)

10 MHz Bandwidth Repetitive Store

100 kHz Bandwidth Single Shot Store

Pre-trigger

10 Bit Vertical Resolution

Stored X versus Y Display

Roll Mode

X-Y Plotter Output with Penlift

APPLICATIONS

Mechanical Transducers

Biophysical

GPIB

The TEKTRONIX 5223 Digitizing Oscilloscope is a digital storage instrument with a real-time bandwidth of 10 MHz. The 5223 is capable of displaying real-time and stored waveforms simultaneously (four real-time waveforms and four stored waveforms, if dual channel amplifier units are used); the real-time waveforms need not be related to the stored waveforms. Stored waveforms can be expanded vertically and horizontally up to a factor of 10, using front-panel controls. The left and right stored vertical signals can be displayed against each other in the X-Y mode, using the L vs R front-panel display function. The roll mode is useful when viewing low-frequency signals. Rear-panel connectors provide access to the internal analog and control signals to record stored waveforms using associated equipment (e.g., X-Y plotter). The 5223 accepts most 5000 Series Plug-in units; the flexibility of the plug-in feature, and variety of plug-in units available, allows the system to be used for many measurement applications.

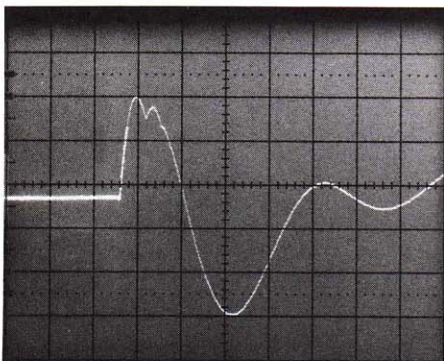

Single-shot data can be captured and stored automatically without the operator's presence. Pretrigger signal portion has an intensified trace for easy reference.

The digital storage functions can only be accessed or enabled by using the 5B25N Time Base.

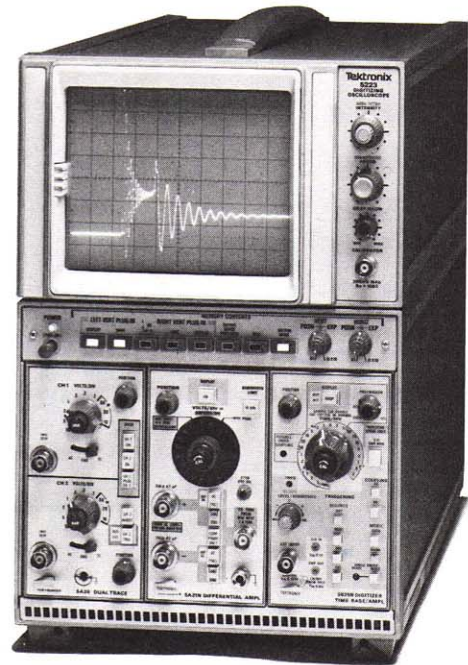

DISPLAY and SAVE Functions

The DISPLAY buttons allow the 5223 to digitize the signals originating from the corresponding vertical compartments (left and right). The digitized display is continuously updated as long as a triggered sweep occurs, or until the SAVE button is pushed. The SAVE buttons freeze the memory contents. Up to four channels may be displayed and saved simultaneously.

L vs R Display

This function will display the memory contents of the left compartment versus the right compartment. The left defines the vertical axis and the right compartment defines the horizontal axis. Since the X-Y display is from memory, the real-time sweep is still in the standard Y-time format and may be displayed simultaneously.

ROLL Display

For continuous data stream monitoring of biomedical or low frequency events, Roll Mode digitizes the signal and displays the latest

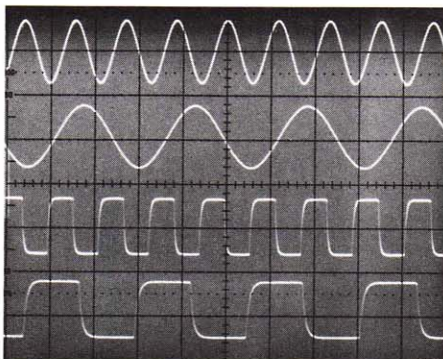

Up to four channels may be stored at a time either Single Shot or Repetitive.

acquired point at the right of the CRT while the previous data moves from right to left. The display appears much like a strip chart recorder. Available on the sweep range of 5 sec/div to 0.1 sec/div.

VECTOR Display

When selected, a continuous trace connects the discrete data points into a clear and comprehensive display. This eliminates perception problems of scattered data to reduce interpretation errors.

OUTPUT SAVED Displays

When pressed, an analog output of the displayed saved waveforms is activated for driving conventional X-Y analog plotters. Pen lift is also provided and is activated before and after each waveform is output. Up to four waveforms may be output.

DISPLAY OUT SPEED Control (rear panel)

This controls the X-Y plotter output speed to adjust for differences in plotter speeds and response.

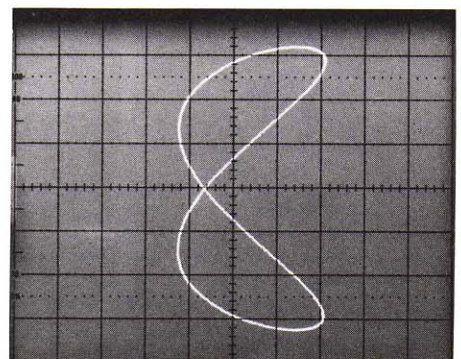

By pressing the L vs R button, the memory contents of one vertical compartment are displayed against that of the other.

VERTICAL REAL TIME SYSTEM

Channels — Two plug-in compartments; compatible with 5000 Series Plug-ins.
Mainframe Bandwidth — 10 MHz with 5A38, 5A45 or 5A48.
Mainframe Step Response — 35 ns.
Chop Mode — 100 chopped segments/division unexpanded with 5B25N Time Base.
Delay Line — Permits viewing leading edge of displayed waveform.

HORIZONTAL REAL TIME SYSTEM

Channel — Single compartment compatible with 5000 Series Time Bases and amplifiers. 5B25N must be used in storage modes.
Fastest Calibrated Sweep Rate — 20 ns/div.
X-Y Mode — <2° phase shift, dc to 20 kHz between either vertical compartment and horizontal compartment.

DIGITAL STORAGE (with 5B25N)

Vertical Resolution — 10 bits (100 pts/div unexpanded).
Display Memory Size — 1k points per vertical compartment, shared by multiple trace plug-ins.
Sample Rate — Maximum of 1 μ s/pt (1 MS/s). Actual sample rate depends on time base setting.
Fastest Single Shot Sweep Speed — 100 μ s/div.
External Clock In — Maximum of 1 MS/s (1 μ s/pt). TTL compatible.
Equivalent Time Bandwidth — 10 MHz.
Acquisition Window — ± 4 divisions vertically and ± 5 divisions horizontally from center screen.
Accuracy — Determined by plug-ins. Refer to plug-in specifications.
X-Y — (Left vs right single channel mode only excluding 100 μ s/division sweep range). Maximum of 5° phase shift between vertical compartments up to 10 MHz using two identical 5400 Series vertical plug-ins.

MEMORY CONTROLS

Display and Save — Controls for each vertical compartment. X-Y (left vs right), Data Out, Roll, Vector Mode, Horizontal and Vertical positioning, and expansion ($\geq 10:1$).
Data Out — Analog voltage of stored signal. 200 mV/div $\pm 5\%$. Output rate variable with rear panel control. Pen lift available on rear panel (normally open).

OUTPUT/INPUTS

Plug-in Signal Outputs:
Left Vertical, Right Vertical, Horizontal Compartments — 50 mV/division $\pm 5\%$ from 50 Ω .
Left, Right Vertical Compartments — dc ≥ 10 MHz; horizontal compartment - dc ≥ 7 MHz.
Time Base Gate — TTL compatible, positive going.
Remote Single Sweep Reset — Rear panel BNC closure to ground resets sweep.
External Z-Axis Input — Usable, dc ≥ 5 MHz Voltage swing of 5 volts will fully modulate beam dc ≥ 1 MHz. Negative voltage will blank trace. Maximum input voltage is 40 V (dc + peak ac).
Calibrator:
Voltage Output — Squarewave, positive going from ground. Amplitude is 300 mV $\pm 1\%$.
Current Output — 3 mA $\pm 1\%$ available through calibrator output with optional BNC to current loop adapter.

CRT AND DISPLAY FEATURES

CRT — 8 x 10 divisions with 1.22 cm/div. Internal illuminated graticule.
Phosphor — P31.
Acceleration Potential — 15 kV.
Camera Power — Compatible with TEKTRONIX C-59 Camera.

POWER REQUIREMENTS

Line Voltage Range — 90-117 V, 102-132 V, 191-249 V, 204-250 V max.
Line Frequency — 48-62 Hz (48-440 Hz, Option 05).
Max Power Consumption — 145 W at 120 V, 60 Hz.

OPTIONS

Option 05 Line Frequency Change (48-440 Hz) — Converts the R5223 to 48-440 Hz operation.
Option 10 GPIB Interface — For I/O of stored waveforms and control of 5223 digital storage functions (except vert and horiz expansion and position controls). Waveform output format is selectable through the interface for either BINARY or ASCII.

I/O Records — Waveforms.
Device Address — Selectable via rear panel switch.
Talk/Listen — Full bi-directional transfer of waveforms plus remote manipulation of storage controls.
Talk Only — Continuous output of digitized waveform to maximum sweep of 20 ms/div (dependent on other instruments on bus).
Implemented Interface Functions:
SH1 Complete Source Handshake
AH1 Complete Acceptor Handshake
T5 Talker Function
L4 Listener Function
SR1 Complete Service Request Capability
RL2 Remote/Local Capability
DC1 Complete Device Clear Capability

PLUG-IN COMPATIBILITY

All 5000 Series Plug-ins are compatible in the standard oscilloscope display mode. The 5L4N, 5A18N, 5A26, 5A48 plug-ins may require modification for optimum use with digital storage operation. The 5A14N is not recommended for use in storage mode.

5B25N

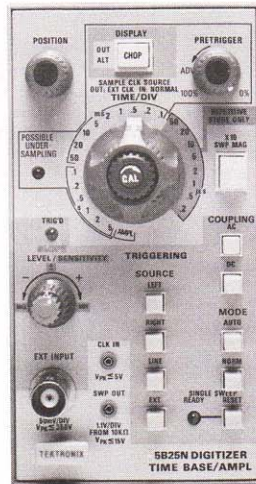

5B25N Digital Time Base

The 5B25N is required with the 5223 to enable the digital functions and waveform acquisition. The 5B25N combines the performance of a standard 5B40 Time Base for real time displays and a crystal controlled clock to drive the digitizer. Additional features of the 5B25N aid in the triggering and acquisition signals to be stored.

Pre-Trigger

For viewing events which occur prior to the trigger, a PRETRIGGER control is continuously variable from 0% to 100% of full screen. An intensified zone is generated which corresponds to the amount of pretrigger selected. This intensified zone remains with the saved waveform. Pre-trigger is available from 5 sec/div to 0.1 ms/div.

Possible Undersampling Indicator

To aid in eliminating aliasing, an LED indicator illuminates when the ratio of sampling frequency to trigger frequency is less than eight.

Bi-Slope Triggering

Besides the standard positive and negative slope and level control, the 5B25N has Bi-Slope triggering. When selected, Bi-Slope will trigger on either a positive or negative slope and the threshold or sensitivity is controlled by the trigger level knob. This eliminates the uncertainty of which slope to select, for example, in collision and destructive testing where a wrong guess could be costly.

Sampling Rate

For single shot acquisition, the 5B25N has a maximum sample rate of 1 MHz at 0.1 ms/div.

Repetitive Store

For repetitive signals, the 5B25N controls the equivalent time sampling feature of the 5223 to allow digitizing from 50 μ s/div to 0.2 μ s/div.

External Clock Input

Clock-In pin jack allows the user to introduce an external sampling clock. Maximum input frequency of 1 MHz, with TTL threshold, and 5 V peak input voltage.

DIGITIZER-RELATED FUNCTIONS (5223 Mainframe Only)

| Overall Speed Accuracy Of Digitized Signal— (Center 8 Div). Excluded portions first 200 ns or 0.2 div of each waveform | Digitized Waveform | Digitized Waveform Relative To Real-Time Waveform | |
|--|--------------------|---|-------|
| | | CAL | UNCAL |
| 2 and 5 s/div | 3% | 4% | 6% |
| 1 s-0.1 ms/div | 3% | 3% | 5% |
| 50 μ s-0.2 μ s/div | 3% | 3% | 3% |

See page 213 for details.

ORDERING INFORMATION

| | |
|---|---------------|
| 5223 Digitizing Oscilloscope | \$4505 |
| R5223 Rackmount | \$4655 |
| Option 05 Line Freq change (R5223 only) | Add \$200 |
| Option 10 GPIB Interface | Add \$500 |
| 5B25N Time Base | \$725 |

INTERNATIONAL POWER CORD AND PLUG OPTIONS

| | |
|--|-----------|
| Option A1 Universal Euro 220 V/16A | No Charge |
| Option A2 UK 240 V/13A | No Charge |
| Option A3 Australian 240 V/10A | No Charge |
| Option A4 North American 240 V/15A | No Charge |

5440/R5440

Low Cost

Dc to 50 MHz

Sampling to 1 GHz

CRT Readout

3 Plug-in Flexibility

Choice of 20 Plug-ins

Bench to Rack Convertibility

APPLICATION

Electrical Engineering

Component Testing

Ultra Sonics

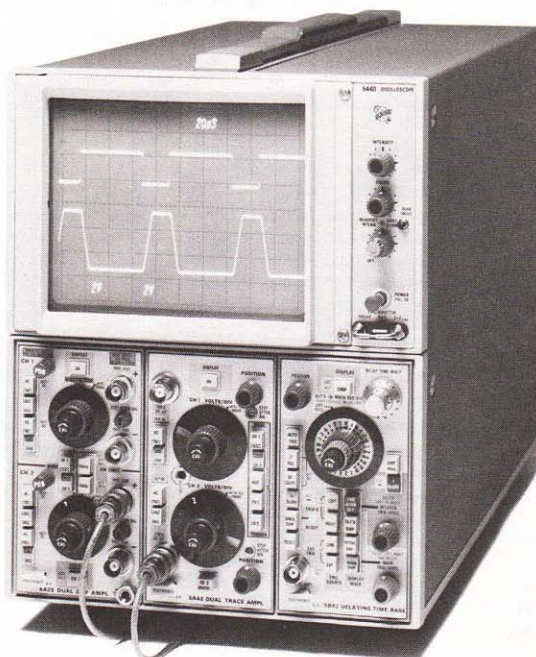

The 5440 combines versatility and low cost in a 50 MHz general-purpose, plug-in oscilloscope. It features CRT readout of plug-in scale factors, a 3 plug-in mainframe, a choice of 20 plug-ins* and bench to rack convertibility.

CRT readout displays plug-in scale factors on the CRT, so measurement time and operator errors are reduced by taking into account magnifiers and probe attenuators. It can also be accessed externally. This unique ability can be used to read out dates, picture numbers, digital clock times, etc.

All the plug-ins in the 5000 Series are compatible with the 5440.**

The wide variety of plug-ins available lets you configure your oscilloscope to meet your needs today as well as tomorrow: from a single-trace, single time-base configuration for production monitoring, to 4-trace, delayed sweep for logic work, to 4-trace differential amplifiers for transducer measurements, to dual-trace, delayed sweep for general purpose measurements.

If you're looking for a general-purpose oscilloscope, the 5440 gives you the most versatility and performance at the lowest price.

*Plug-ins with a suffix N (5B12N, etc.) do not provide CRT readout.

**The 5B10N and 5B12N Time Bases do not permit viewing the leading edge of a triggered waveform when used in the 5400 Series.

VERTICAL SYSTEM

Channels — Left and center plug-in compartments are compatible with all 5000 Series Plug-ins. CRT readout is not available with plug-ins having a suffix N (5B10N, etc.).

Deflection Factor — Determined by plug-in unit.

Bandwidth — 50 MHz, determined by plug-in unit.

Chopped Mode — The 5440 will chop between channels at ≈ 25 to 100 kHz, depending on plug-ins and operating modes.

Alternate Mode — Each amplifier plug-in is swept twice before switching to the next. A single-trace amplifier is swept twice and each channel of a dual-trace amplifier is swept once before the 5440 switches to the second amplifier.

HORIZONTAL SYSTEM

Channel — Right-hand plug-in compartment compatible with all 5000 Series Plug-ins. CRT readout is not available for plug-ins with a Suffix N.

Internal Trigger Mode — Left vertical, center vertical.

Fastest Calibrated Sweep Rate — 10 ns/div, determined by plug-in.

X-Y Mode — Phase shift within 2° from dc to 20 kHz.

CRT AND DISPLAY FEATURES

CRT — Internal parallax-free 8 x 10 div (1.22 cm/div) graticule with edge-lit illumination.

Phosphor — P31 Standard, P7 or P11 optional.

Accelerating Potential — 15 kV.

External Intensity Input — +5 V turns beam on from off condition. -5 V turns beam off from on condition. Frequency range dc to 2 MHz. Input R and C is ≈ 10 k Ω paralleled by ≈ 40 pF. Max input is ± 50 V (dc + peak ac).

OTHER CHARACTERISTICS

Calibrator — Voltage amplitude is 400 mV within 1%. Current is 4 mA within 1%. Frequency is 2 times the line frequency.

Minimum Photographic Writing Speed — Using Polaroid film 20,000 ASA without film fogging. Writing speed can be increased with the TEKTRONIX Writing Speed Enhancer (see Camera section for more information).

| Writing Speed cm/ μ s | | | | Camera | Lens |
|---------------------------|----------|--------------|----------|--------|----------|
| P31 Phosphor | | P11 Phosphor | | | |
| 20,000 ASA | 3000 ASA | 20,000 ASA | 3000 ASA | C-59P | f/2.8 |
| 180 | 90 | 245 | 125 | | 0.67 mag |
| 330 | 160 | 450 | 230 | * ** | f/1.9 |
| | | | | C-50P | 0.7 mag |

*Slight cropping of the graticule corners.

**Requires optional battery pack (016-0270-02) for operation with the 5440.

Beam Finder — Intensifies trace and brings it into graticule areas.

Ambient Temperature — Performance characteristics valid from 0°C to $+50^\circ$ unless otherwise specified.

Line Voltage Range — 100, 110, 120, 200, 220, and 240 V ac $\pm 10\%$; (Except that max input should not exceed 250 V ac) internally selected with quick change jumpers. Line frequency range, 48 to 440 Hz.

Max Power Consumption — 100 W at 120 V ac, 60 Hz.

OPTIONS

Option 01 Without CRT Readout — The 5440 may be ordered without CRT readout. This feature can easily be added later with a conversion kit.

Option 03 User Addressable CRT Readout — An additional CRT readout access is available for the operator to program two 10-digit characters such as time, operator name, or test number. The additional display is useful for photographic records and is programmed by external resistors and switches.

Option 04 Protective Panel Cover (Cabinet Model Only) — The 5440 may be ordered with a protective front-panel cover. The cover protects the front panel and knobs during transportation and storage.

For Recommended Cameras — See Camera section, page 316.

ORDERING INFORMATION

(Plug-ins not included)

The 5440 may be ordered as a cabinet-model oscilloscope equipped with a tilt bail, or as a 5.25 in rackmount oscilloscope with slide-out assembly.

5440 Oscilloscope \$2390

R5440 Oscilloscope (Rackmount) \$2440

OPTIONS

Option 01 without CRT Readout Sub \$300

Option 03 User Addressable CRT Readout Add \$75

Option 04 Protective Panel Cover (Cabinet Model Only) Add \$25

Option 76 P7 Phosphor \$35

Option 78 P11 Phosphor \$35

CONVERSION KITS

Cabinet-to-Rackmount, 040-0583-02 \$200

Rackmount-to-Cabinet, 040-0584-03 \$125

CRT Readout, 040-0691-01 \$675

INTERNATIONAL POWER CORDS AND PLUG OPTIONS

Option A1 Universal Euro 220 V/16A No Charge

Option A2 UK 240 V/13A No Charge

Option A3 Australian 240 V/10A No Charge

Option A4 North American 240 V/15A No Charge

5441/R5441

- Low Cost
- Variable Persistence Storage
- CRT Readout
- Dc to 50 MHz
- 3 Plug-in Flexibility
- 20 Versatile Plug-ins
- Bench to Rack Convertibility
- 5 div/μs Stored Writing Speed

APPLICATIONS

- Ultra Sonics
- Low Power Laser
- Fiber Optics

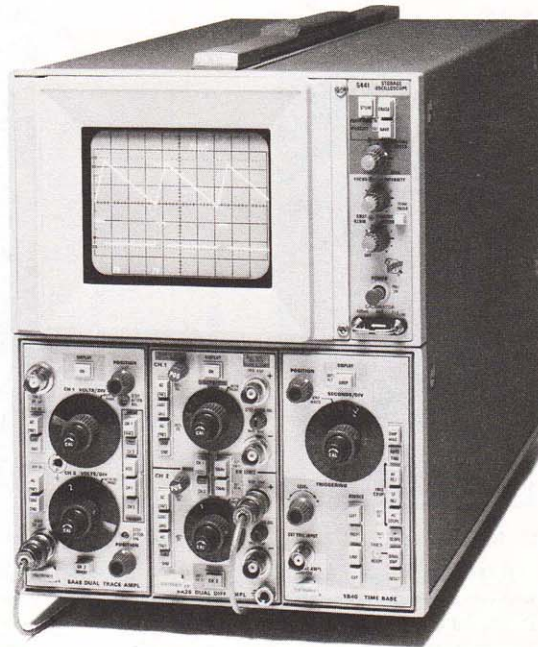

With the 5441 Variable Persistence Storage Oscilloscope, view time at normal intensity can be varied from a fraction of a second to more than 5 minutes. In the save mode, signals can be viewed at lower intensity for up to an hour.

High-speed events that occur only once or at very low repetition rates are easily observed. You can make low frequency measurements more easily and accurately by eliminating flicker or transforming a slowly moving dot into a stable display. Repetitions of the same signal can be compared simultaneously to detect changes in amplitude or phase. The integrating effect of variable persistence can be used to suppress the random noise that obscures low signal-to-noise ratio waveforms.

The 5441 enhances the capabilities of the 5000 Series Sampler and Spectrum Analyzer Plug-ins. In sampling applications, discrete dot traces are converted into a continuous waveform by holding repeated sweeps on the CRT.

In spectrum analysis, slow scan rates are used to maximize resolution. With the 5441, it is easy to display a full-scan pattern simultaneously even when the scan rate yields full-scale periods of more than a second.

Like other 5400 Series Oscilloscopes, the 5441 offers CRT readout of deflection factors for convenient, error-free measurements and optional user-programmable CRT readout of test information for ready identification and easy photographic recording. With the flexibility of a 3 plug-in mainframe and a choice of 20 plug-ins, you can make virtually any measurement from dc to 50 MHz.

VERTICAL SYSTEM

Channels — Left and center plug-in compartments compatible with all 5000 Series Plug-ins. CRT readout not available for plug-ins with suffix N.

Deflection Factor — Determined by plug-in.

Bandwidth — 50 MHz, determined by plug-in.

Chopped Mode — The 5441 will chop between channels at ≈25 kHz to 100 kHz, depending on plug-ins and operating modes.

Alternate Mode — Each plug-in is swept twice before switching to the next. A single-trace amplifier is swept twice and each channel of a dual-trace amplifier is swept once before the 5441 switches to the second amplifier.

HORIZONTAL SYSTEM

Channel — Right-hand plug-in compartment compatible with all 5000 Series Plug-ins. CRT readout not available for plug-ins with suffix N.

Internal Trigger Mode — Left vertical, right vertical.

Fastest Calibrated Sweep Rate — 10 ns/div, determined by plug-in.

X-Y Mode — Phase shift within 2° from dc to 20 kHz.

CRT AND DISPLAY FEATURES

CRT — Internal, parallax-free, 8 x 10 div (0.9 cm/div) graticule with edge-lit illumination.

Persistence — Continuously variable, may be turned off when not needed, thus producing high-contrast stored displays without the characteristic fading of variable persistence.

Phosphor — P31.

Accelerating Potential — 8.5 kV.

Max Stored Writing Speed — Writing speed greater than 5 div/μs for a view time of 15 s.

Storage View Time — The view time is the amount of time the stored signal can be viewed before it fades away.

At the max writing speed the view time is 15 seconds or 0.25 minutes with the writing speed control fully cw. Adjusting the stored intensity ccw will reduce the stored writing speed, but view time can be increased up to 5 minutes (see the chart next column).

Save Mode — Extends view time of stored displays up to 1 hr; prevents erasure of stored display and storage of unwanted displays.

Erase Time — 0.5 s ± 10%.

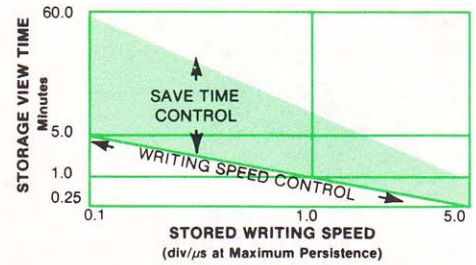

External Intensity Input — +5 V turns beam on from off condition. —5 V turns beam off from on condition. Dc to 2 MHz usable frequency range. Input R and C ≈10 kΩ paralleled by ≈40 pF. Max input 50 V (dc + peak ac).

OTHER CHARACTERISTICS

Beam Finder — Intensifies trace and brings it into graticule area.

Auto Focus — Reduces the need for manual focusing with changes in intensity after the front-panel FOCUS control has been set.

Calibrator — Voltage amplitude 400 mV ± 1%. Current amplitude 4 mA ± 1%. Frequency is 2 times line frequency.

Ambient Temperature — Performance characteristics valid from 0°C to +50°C unless otherwise specified.

Line Voltage Ranges — 100, 110, 120, 200, 220, and 240 V ac ± 10%. (Except that max input should not exceed 250 V ac.) Internally selected with quick change jumpers. Line frequency range, 48 to 440 Hz.

Max Power Consumption — 100 W at 120 V ac, 60 Hz.

OPTIONS

Option 01 without CRT Readout — The 5441 may be ordered without CRT readout. This feature can easily be added later with a conversion kit.

Option 03 User Addressable CRT Readout — CRT readout access allows the operator to program up to two 10-digit words.

Option 04 Protective Panel Cover (Cabinet Model Only) — The 5441 may be ordered with a protective front-panel cover. The cover protects the front panel and knobs during transportation and storage.

For Recommended Cameras — See Camera section, page 316.

ORDERING INFORMATION

(Plug-ins not Included)

- 5441 Oscilloscope** \$4060
- R5441 Oscilloscope (Rackmount)** \$4125

OPTIONS

- Option 01 without CRT Readout** Sub \$300
- Option 03 User Addressable CRT Readout** Add \$75
- Option 04 Protective Panel Cover (Cabinet Model Only)** Add \$25

CONVERSION KITS

- Cabinet-to-Rackmount, 040-0583-02** \$200
- Rackmount-to-Cabinet, 040-0584-03** \$125
- CRT Readout, 040-0691-01** \$675

INTERNATIONAL POWER CORDS & PLUG OPTIONS

- Option A1 Universal Euro 220 V/16A** No Charge
- Option A2 UK 240 V/13A** No Charge
- Option A3 Australian 240 V/10A** No Charge
- Option A4 North American 240 V/15A** No Charge

5A38

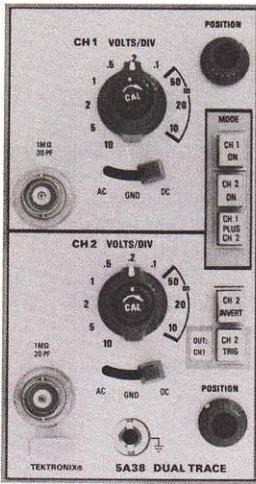

Dc to 35 MHz
5A38 Dual-trace Amplifier

Low Cost

Dc to 35 MHz Bandwidth
10 mV/div to 10 V/div Calibrated
Deflection Factors

The 5A38 is a dual-trace, 35 MHz plug-in amplifier for use only in the 5223 and the 5400 Series Mainframes. It features 10 mV/div sensitivity and CRT readout of deflection factor.*

Bandwidth — Dc coupled, to ≥ 35 MHz. Lower end response, ac coupled, ≤ 10 Hz.

Display Modes — Channel 1 only, Channel 2 only (normal or inverted), Dual-trace, and Added. Alternated or chopped operation determined by time base plug-in. Internal trigger selectable from Channel 1 or Channel 2.

Rise Time — ≤ 10 ns.

Deflection Factors — Calibrated deflection factors from 10 mV/div to 10 V/div in a 1-2-5 sequence. Accuracy $\leq 3\%$ from 15°C to 35°C , 4% from 0°C to 50°C . A continuously variable control provides $\geq 2.5\text{X}$ additional attenuation on each range.

Common-Mode Rejection Ratio — $\geq 50:1$ up to 1 MHz.

Channel Isolation — $\geq 50:1$ to 35 MHz with both traces displayed.

Input R and C — 1 M Ω shunted by ≈ 20 pF.

Max Input Voltage — Dc coupled, 250 V (dc + peak ac); ac coupled, 500 V (dc + peak ac). Ac component 500 V p-p max at 1 kHz or less.

Stability — ≤ 0.3 mV vertical shift in any one minute after one hour warm-up, ambient temperature and line voltage held constant. ≤ 0.2 mV/ $^\circ\text{C}$ vertical shift with line voltage held constant.

*CRT readout not functional in 5223.

5A48



Dc to 50 MHz
5A48 Dual-trace Amplifier

Dc to 50 MHz Bandwidth

1 mV/div to 10 V/div Calibrated
Deflection Factors

The 5A48 is a dual-trace 50 MHz plug-in amplifier for use only in the 5223 and the 5400 Series Mainframes. The 5A48 features five operating modes, selectable trigger source, and CRT readout of deflection factor.*

Bandwidth — Dc coupled, dc to at least 50 MHz at 5 mV/div to 10 V/div, decreasing to dc to 25 MHz at 1 mV/div and 2 mV/div (3 dB down). Ac coupled, 10 Hz or less (1.0 Hz with a 10X probe) at all deflection factors (3 dB down).

Display Modes — Channel 1 only, Channel 2 only (normal or inverted), Dual-trace, Added, Alternated, Chopped (determined by time-base plug-in horizontal compartment). Internal trigger source is selectable from Channel 1 or Channel 2.

Rise Time — 7 ns or less (5 mV/div to 10 V/div), 14 ns or less (1 mV/div and 2 mV/div).

Deflection Factors — Calibrated deflection factors from 1 mV/div to 10 V/div in a 1-2-5 sequence. Accuracy $\leq 5\%$ at 1 mV/div and 2 mV/div, $\leq 3\%$ from 5 mV/div to 10 V/div from 15°C to 35°C , $\leq 4\%$ from 5 mV/div to 10 V/div from 0°C to 50°C . A continuously variable control provides $\geq 2.5\text{X}$ additional attenuation on each range.

Common-Mode Rejection Ratio — $\geq 50:1$ from 5 mV/div to 10 V/div, up to 1 MHz. $\geq 20:1$ from 1 mV/div to 2 mV/div, up to 1 MHz.

Input R & C — 1 M Ω within 1%, ≈ 24 pF.

Max Input Voltage — Dc coupled, 250 V (dc + peak ac); ac coupled, 500 V (dc + peak ac). Ac component 500 V p-p max, 1 kHz or less.

Stability — ≤ 0.3 mV vertical shift in any one minute after one hour warm-up, ambient temperature and line voltage held constant. ≤ 0.2 mV/ $^\circ\text{C}$ vertical shift with line voltage held constant.

*CRT readout not functional in 5223.

For recommended probes — refer to page 206.

5B40



Time Base
5B40 Time Base

Low Cost

10 ns/div to 5 s/div
Calibrated Time Base

Triggering to 50 MHz

The 5B40 Time Base is designed for use only in 5400 Series Mainframes. It features sweep rates from 10 ns/div to 5 s/div and CRT readout of the sweep rate selected.

Sweep Rate — 0.1 $\mu\text{s}/\text{div}$ to 5 s/div in 24 calibrated steps (1-2-5 sequence). 10 ns/div is fastest sweep rate obtained with X10 magnifier. Uncalibrated, continuously variable between steps and up to 12.5 s/div.

Sweep Accuracy — Measured in 5400 Series Oscilloscope over center 8 graticule divisions. Valid for 100 div of magnified sweep after the first 30 ns.

| Time/Div | Unmagnified | | Magnified | |
|---|----------------|--------------|----------------|--------------|
| | +15°C to +35°C | 0°C to +50°C | +15°C to +35°C | 0°C to +50°C |
| 1 s/div to 0.5 $\mu\text{s}/\text{div}$ | 3% | 4% | 4% | 5.5% |
| 5 s/div and 2 s/div | | | | |
| 0.2 $\mu\text{s}/\text{div}$ and 0.1 $\mu\text{s}/\text{div}$ | 4% | 5% | 5% | 6.5% |

| Coupling | Frequency Range | Minimum Signal Required | |
|----------|--|-------------------------|-----------------|
| | | Int | Ext |
| Dc | Dc to 10 MHz 10 MHz to 60 MHz | 0.4 div 1.0 div | 60 mV 150 mV |
| Ac | Trigger requirements increase below 50 Hz. | | |
| Lf Rej | Trigger requirements increase below 7.5 kHz. | | |
| Hf Rej | Trigger requirements increase above 50 kHz. | | |

Single Sweep — Triggering requirements are the same as normal sweep. When triggered, sweep generator produces only one sweep.

External Trigger Input — Max input voltage is 350 V dc + peak ac, 350 V p-p ac at ≤ 1 kHz. Input R and C is 1 M Ω paralleled by ≈ 24 pF. Trigger level range is $\geq \pm 1.5$ V.

External Horizontal Input — Deflection factor is 50 mV/div $\pm 3\%$. Input R and C is 1 M Ω paralleled by ≈ 24 pF. Dc coupled bandwidth is dc to ≤ 2 MHz. The ac coupled lower response is ≤ 50 Hz. Max input voltage is 350 V (dc + peak ac) or 350 V p-p ac at ≤ 1 kHz.

5B42 Delaying Time Base

10 ns/div to 5 s/div Calibrated Time Base

Single-Sweep Operation

Triggering to 50 MHz

The 5B42 Delaying Time Base is designed for use in 5400 Series Mainframes. The 5B42 is designed so that the user may easily operate the time base in the many applications where delayed sweep and sweep rates up to 10 ns/div are required.

The 5B42 also features CRT readout and an edge-lighted seconds/div selector switch.

Sweep Rate — 0.1 μ s/div to 5 s/div in 24 calibrated steps (1-2-5 sequence). 10 ns/div is the fastest calibrated sweep rate obtained with X10 magnifier. Uncalibrated, continuously variable between steps and to 12.5 s/div.

Sweep Accuracy — Measured over the center 8 div. Same as 5B40. See chart in left column.

5B42

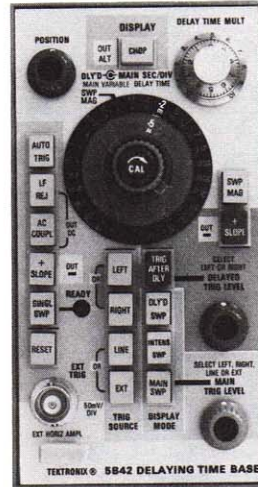

Delaying Time Base

5B25N Digital Time Base

Bi-Slope Triggering

20 ns/div to 5 s/div Calibrated Time Base

Triggering to 15 MHz

The 5B25N is designed specifically for use in the 5223 Digital Storage Oscilloscope. PRETRIGGER is only available with the 5223 (see page 208). However, the standard analog sweep features including Bi-Slope Triggering and X10 MAG are compatible with 5400 Series Mainframes.

CHARACTERISTICS

BI-SLOPE TRIGGERING

Besides the standard positive and negative slope and level control, the 5B25N has Bi-Slope triggering. When selected, Bi-Slope will trigger on either a positive or negative slope and the threshold or sensitivity is controlled by the trigger level knob. This eliminates the uncertainty of which slope is select, for example, in collision and destructive testing where a wrong guess could be costly.

Modes — Auto, Normal, Single Sweep.

Single Sweep — Triggering requirements are the same as normal sweep. When triggered, sweep generator produces only one sweep.

External Trigger Input — Max input voltage is 350 V-peak. Input R and C is 1 M Ω paralleled by \approx 24 pF.

External Horizontal Input — Deflection factor is 50 mV/div \pm 3%. Dc coupled bandwidth is dc to 2 MHz.

Sweep Rate — 0.2 μ s/div to 5 s/div in 24 calibrated steps (1-2-5 sequence). 20 ns/div is fastest sweep rate obtained with X10 magnifier. Uncalibrated, continuously variable between steps and up to 12.5 s/div.

Sweep Accuracy — Measured in 5400 Series Oscilloscope over center 8 graticule divisions. Valid for 100 div of magnified sweep after the first 30 ns.

| Time/Div | Unmagnified | | Magnified | |
|----------------------------|----------------|--------------|----------------|--------------|
| | +15°C to +35°C | 0°C to +50°C | +15°C to +35°C | 0°C to +50°C |
| 1 s/div to 0.2 μ s/div | 3% | 4% | 4% | 5% |
| 5 s/div and 2 s/div | 4% | 5% | 5% | 6% |

5B25N

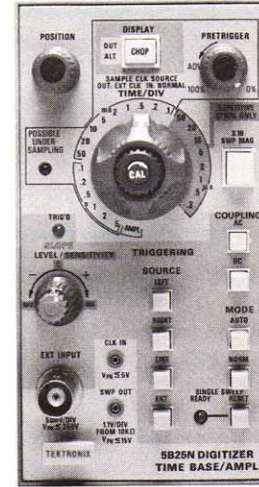

Digitizer Time Base/Amplifier

TRIGGERING

| Slope | Frequency Range | Minimum Signal Required | |
|------------------|--------------------------------|-------------------------|-----------------|
| | | Int | Ext |
| + or - | Dc to 1 MHz 1 MHz to 15 MHz | 0.4 div 0.6 div | 50 mV 200 mV |
| \pm (Bi-Slope) | DC ¹ to 1 MHz | \pm 0.5 div | \pm 50 mV |

¹30 Hz when ac coupled.

5B25N CHARACTERISTICS WHEN USED WITH THE 5223 MAINFRAME

PRE-TRIGGER

For viewing events which occur prior to the trigger, a PRE-TRIGGER control is continuously variable from 0% to 100% of full screen. An intensified zone is generated which corresponds to the amount of pretrigger selected. This intensified zone remains with the saved waveform. Pre-trigger is available from 5 s/div to 0.1 ms/div.

SAMPLING RATE

For single shot acquisition, the 5B25N has a maximum sample rate of 1 MHz at 0.1 ms/div (only when used with 5223).

REPETITIVE STORE

For repetitive signals, the 5B25N controls the equivalent time sampling feature of the 5223 to allow digitizing from 50 μ s/div to 0.2 μ s/div.

EXTERNAL CLOCK INPUT

Clock-In pin jack allows the user to introduce an external sampling clock. Maximum input frequency of 1 MHz, with TTL threshold, and 5 V peak input voltage.

Digitizer-Related Functions (6223 Mainframe Only)

| Overall Speed Accuracy Of Digitized Signal— (Center 8 Div). Excluded Portions: First 200 ns or 0.2 Div of Each Waveform | Digitized Waveform | Digitized Waveform Relative To Real-Time Waveform | |
|---|--------------------|---|-------|
| | | CAL | UNCAL |
| 2 and 5 s/div | 3% | 4% | 6% |
| 1 s - 0.1 ms/div | 3% | 3% | 5% |
| 50 μ s - 0.2 μ s/div | 3% | 3% | 3% |

ORDERING INFORMATION

| | |
|---------------------------|--------|
| 5B25N Digital Time | \$725 |
| 5B42 Delaying Time Base | \$1110 |
| 5A38 Dual-Trace Amplifier | \$585 |
| 5B40 Time Base | \$600 |
| 5A48 Dual-Trace Amplifier | \$860 |

| TRIGGERING | | | |
|-----------------|--------------------------------------|-------------------------|--------|
| Coupling | Frequency Range | Minimum Signal Required | |
| | | Int | Ext |
| Dc | 5400 ampl | 0.4 div | 100 mV |
| | 5400 ampl | 1.0 div | 400 mV |
| | 5100 ampl | 0.4 div | 100 mV |
| Ac | Requirements increase below 50 Hz. | | |
| Ac Lf Rejection | Requirements increase below 7.5 kHz. | | |

Single Sweep — Triggering requirements are the same as normal sweep. When triggered, sweep generator produces one sweep.

External Trigger Input — Max input voltage is 350 V (dc + peak ac), 350 V p-p ac at 1 kHz or less. Input R and C is 1 M Ω within 2%, \approx 20 pF. Trigger level range is at least \pm 2.5 V.

DELAYING SWEEP CHARACTERISTICS

Delay Time Multiplier Range — 0.2 to 10 times the TIME/DIV setting.

Differential Time Measurement Accuracy — Within 1% plus 0.2% of full scale from 1 μ s to 0.5 s delay time. Within 2% plus 0.2% of full scale of 1 s to 5 s delay time.

Jitter — <0.05% of the time represented by one div of delay-time sweep selected.

DELAYED SWEEP

Sweep Rate — 0.1 μ s/div to 0.5 s/div in 21 calibrated steps (1-2-5 sequence). 10 ns/div is the fastest calibrated sweep rate obtained with the X10 magnifier.

Sweep Accuracy — Measured over the center 8 div. Same as undelayed sweep. See chart at left.

| TRIGGERING | | | |
|------------|-----------------|---------------------|-----|
| Coupling | Frequency Range | Min Signal Required | |
| | | Int | Ext |
| Dc | 5400 ampl | 0.4 div | |
| | 5400 ampl | 1.0 div | |
| | 5100 | 0.4 div | |

EXTERNAL HORIZONTAL INPUT

Deflection Factor — 50 mV/div within 3%.

Bandwidth — Dc coupled, dc to at least 2 MHz, Ac coupled, 50 Hz or less to at least 2 MHz.

5100 Series Oscilloscopes

Low Cost

Dc to 2 MHz

Sampling to 1 GHz

Choice of 15 Plug-ins

Rear Panel Signal Outputs Optional

COMMON CHARACTERISTICS

for 5110, 5111, 5113, 5115
unless otherwise specified

VERTICAL SYSTEM

Channels — Left and center plug-in compartments compatible with all 5100 Series Plug-ins.

Deflection Factor — Determined by plug-in.

Bandwidth — 2 MHz, determined by plug-in.

Chopped Mode — (5110, 5111, 5115) The mainframe vertical amplifier will chop between left and center plug-in compartments, and/or between two or more amplifier channels. The total time segment per channel is $\approx 5 \mu\text{s}$, consisting of $\approx 3 \mu\text{s}$ displayed, $\approx 2 \mu\text{s}$ blanked. Chop or alternate mode is selected at the time base unit.

Chopped Mode — (5113) The left and right mainframe vertical amplifiers are dedicated to the left and center plug-in compartments. Each mainframe vertical amplifier will chop between two or more channels in their associated plug-in compartments. No channel switching is necessary between left and center plug-in compartments. The total time segment per channel is $\approx 5 \mu\text{s}$, consisting of $3 \mu\text{s}$ displayed, $\approx 2 \mu\text{s}$ blanked. Chop or alternate mode is selected at the time base unit.

Alternate Mode — (5110, 5111, 5115) Each amplifier plug-in is swept twice before switching to the next. A single-trace amplifier is swept twice and each channel of a dual-trace amplifier is swept once before switching to the second amplifier.

Alternate Mode — (5113) Single-trace amplifiers are swept full time. Each channel of a multitrace amplifier is swept once before switching to the next channel. No channel switching is necessary between left and center plug-in compartments.

HORIZONTAL SYSTEM

Channel — Right-hand plug-in compartment compatible with all 5100 Series Plug-ins.

Fastest Calibrated Sweep Rate — $0.1 \mu\text{s}/\text{div}$ (X10 mag) with 5B10N or 5B12N.

X-Y Mode — Phase shift within 1° from dc to 100 kHz.

OTHER CHARACTERISTICS

Ambient Temperature — Performance characteristics valid from $0^\circ\text{C} + 50^\circ\text{C}$.

Line Voltage Ranges — 100, 110, 120, 200, 220, and 240 V ac $\pm 10\%$ (except that max input should not exceed 250 V ac). Internally selected with quick change jumpers. Line frequency range, 48 to 440 Hz.

Typical Power Consumption — For 5110, 53 W. For 5111, 74 W. For 5113, 88 W. For 5115, 74 W.

External Intensity Input — +5 V turns beam on from off condition. -5 V turns beam off from on condition. Frequency range dc to 1 MHz. Input R and C is $\approx 10 \text{ k}\Omega$ paralleled by $\approx 40 \text{ pF}$. Max input $\pm 50 \text{ V}$ (dc + peak ac).

Calibrator — Voltage output 400 mV within 1%. Current output (loop) 4 mA within 1%. Frequency is 2 times line frequency.

Beam Finder — Positions beam on screen regardless of vertical and horizontal position control settings.

5110

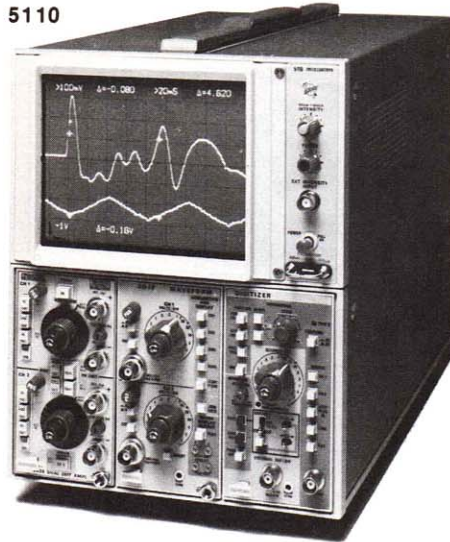

Single Beam

5110

Lowest Cost Single-beam Nonstorage Oscilloscope with Plug-in Configurability

8 Channels at 1 mV/div, 4 Channels at 50 $\mu\text{V}/\text{div}$, 2 Channels at 10 $\mu\text{V}/\text{div}$, with Appropriate Amplifiers

The 5110 is a single-beam nonstorage oscilloscope featuring a large 1.27 cm/div diagonal (6.5 in) CRT.

Tailor your measurement needs with the appropriate plug-in units to obtain high-gain differential (10 $\mu\text{V}/\text{div}$), four channel differential at 50 $\mu\text{V}/\text{div}$, eight-channel displays at 1 mV/div. Or choose from our extra low cost basic amplifier and time-base plug-ins to suit the special needs of education and industry.

When using two amplifiers and a dual time-base plug-in in the dual-sweep mode, the sweeps are slaved to the amplifiers.

CRT AND DISPLAY FEATURES

CRT — Internal 8 x 10 div (1.27 cm/div) parallax-free, non-illuminated graticule.*

Accelerating Potential — 3.5 kV.

Phosphor — P31 standard, P7 or P11 optional.

*Illuminated graticule available at extra cost.

CRT Readout as shown above, is generated via the new 5D10 Waveform Digitizer, expected to be available in the second quarter of 1982. For more information, fill out the request card in this catalog.

5111

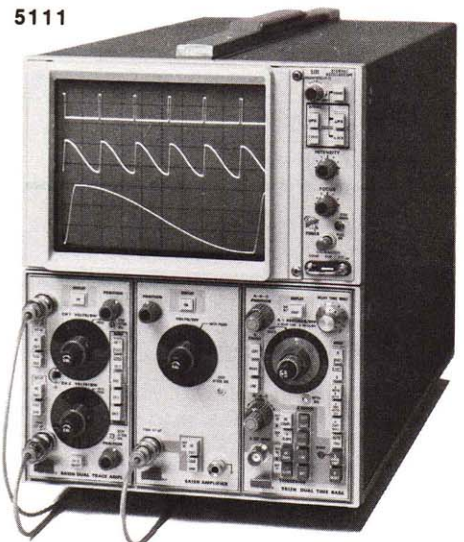

Single Bistable Beam Storage

5111

Single-beam Storage Oscilloscope

Bistable, Split-screen Display

Stored Writing Speed $\geq 20 \text{ div}/\text{ms}$

Storage View Time up to 10 hrs at Reduced Intensity

The 5111 is a single-beam, split-screen, bistable storage oscilloscope with a large-screen, 1.27 cm/div diagonal (6.5 in) display.

The 5111 extends measurement capability into areas requiring retention of single and multitrace displays for long-term examination and/or photography.

The 5111 is particularly useful for recording low and medium speed displays like those found in audio spectrum analysis, semiconductor curve tracing, sampling, vibration analysis, and the biophysical sciences.

When using two amplifiers and a dual time-base plug-in in the dual-sweep mode, the sweeps are slaved to the amplifiers.

CRT AND DISPLAY FEATURES

CRT — Internal 8 x 10 div (1.27 cm/div) parallax-free, non-illuminated graticule.*

Accelerating Potential — 3.5 kV.

Phosphor — Similar to P1.

Max Stored Writing Speed — At least 20 div/ms.

Storage View Time — At least 1 hr at normal intensity; up to 10 hr at reduced intensity, after which time it may be increased to original level.

Erase Time — $\approx 250 \text{ ms}$.

5113

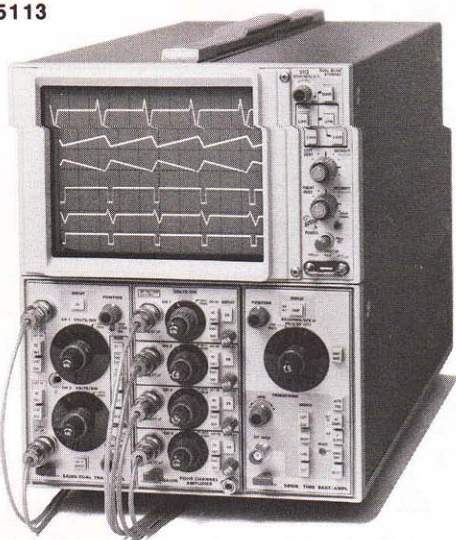

Dual-beam Bistable Storage

5113

Dual-beam Bistable Storage Oscilloscope

Two Independent Vertical Systems

Can Display Two Single-shot Signals without Timesharing, or up to Eight Signals in the Chop Mode

Split-screen Storage. Stored Writing Speed ≥ 20 div/ms.

The 5113 is a dual-beam bistable storage oscilloscope featuring easy-to-use split-screen storage. Stored writing speed is at least 20 div/ms. View time is at least 1 hour at normal intensity and can be increased to 10 hours at reduced intensity.

The 5113 can display two simultaneous events, either single-shot or repetitive, against a common time base within the bandwidth and writing rate limits of the system. Both beams are driven by one set of horizontal deflection plates.

The 5113 is particularly useful in biomedical research where low-repetition-rate stimulus/response potentials need to be observed and recorded.

CRT AND DISPLAY FEATURES

CRT — Internal 8 x 10 div (1.27 cm/div) parallax-free, non-illuminated graticule.*

Accelerating Potential — 3.5 kV.

Phosphor — Similar to P1.

Max Stored Writing Speed — At least 20 div/ms.

Storage View Time — At least 1 hr at normal intensity; up to 10 hr at reduced intensity, after which time it may be increased to original level.

Erase Time — ≈ 250 ms.

*Illuminated graticule available at extra cost.

5115

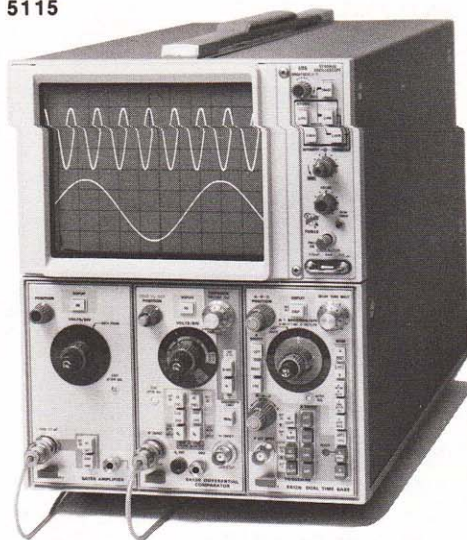

Single-beam Bistable Storage

5115

Single-beam Bistable Storage Oscilloscope

Fastest Stored Writing Speed in the 5100 Series Line:

- ≥ 200 div/ms in Normal-Mode
- ≥ 800 div/ms in Enhanced Mode

Storage View Time up to 10 hrs at Reduced Intensity

The 5115 is a single-beam bistable storage oscilloscope with a writing speed of at least 200 div/ms in the normal-mode and 800 div/ms (> 1000 cm/ms) in the enhanced mode. Storage view time is at least 1 hour at normal intensity. A variable brightness control allows the storage time to be extended to at least 10 hours at reduced intensity, after which time intensity may be increased to original level. Variable brightness also gives optimum photographic results and allows for the integration of multiple traces.

The 5115 is useful in a wide variety of fields, including education, biophysical engineering, component testing, and industrial electronics.

When using two amplifiers and a dual time-base plug-in in the dual-sweep mode, the sweeps are slaved to the amplifiers.

CRT AND DISPLAY FEATURES

CRT — Internal 8 x 10 div (1.27 cm/div) parallax-free, non-illuminated graticule.*

Accelerating Potential — 3.5 kV.

Phosphor — Similar to P1.

Max Stored Writing Speed — At least 200 div/ms in the normal-mode and 800 div/ms in the enhanced mode.

Storage View Time — At least 1 hr at normal intensity; up to 10 hr at reduced intensity, after which time it may be increased to original level.

Erase Time — ≈ 250 ms.

OPTION 07: 5100 SERIES

REAR PANEL SIGNAL OUTPUTS

Left and Center Compartments — Two BNC connectors provide access to the CRT related signals from the left and center plug-in amplifiers. Sensitivity: 0.5 V/CRT division. Output impedance: 1 k Ω .

Right Compartment (Sweep) — One BNC connector provides access to the CRT - related sweep waveform. Sensitivity: 0.5 V/CRT division; positive-going sawtooth. ≥ 5 V. Output Impedance: 1 k Ω .

Right Compartment (Gate) — One BNC connector provides access to TTL compatible gate. Positive-going, coincident with displayed sweep.

X-Y Mode — CRT-related X-Y signals are available at the appropriate rear panel connectors when amplifier plug-ins are used in either the left or center compartment and the right compartment to display X-Y information. Sensitivity (X-Y): 0.5 V/CRT division.

ORDERING INFORMATION

(Plug-ins not included)

Cabinet Models

| | |
|-------------------------|--------|
| 5110 Oscilloscope | \$1300 |
| 5111 Oscilloscope | \$2100 |
| 5113 Oscilloscope | \$2970 |
| 5115 Oscilloscope | \$2235 |

Rackmount Models

| | |
|--------------------------|--------|
| R5110 Oscilloscope | \$1350 |
| R5111 Oscilloscope | \$2150 |
| R5113 Oscilloscope | \$3035 |
| R5115 Oscilloscope | \$2290 |

OPTIONS

Option 02 Protective Panel Cover (Cabinet Models Only) — The cover protects the front panel and knobs during transportation and storage Add \$25

Option 07 Add Rear Panel Signals Out (All Models) Add \$75

Option 76 P7 Phosphor (5110, R5110 Only) Add \$35

Option 78 P11 Phosphor (5110, R5110 Only) Add \$35

CONVERSION KITS

Cabinet-to-Rackmount Conversion Kit, 040-0583-02 \$200

Rackmount-to-Cabinet Conversion Kit, 040-0584-03 \$125

Protective Panel Cover Kit, 040-0620-00 \$40

Rear Panel Signal Outputs Conversion Kit (Option 07) 040-0915-01 \$155

INTERNATIONAL POWER CORDS & PLUG OPTIONS

Option A1 Universal Euro 220 V/16A No Charge

Option A2 UK 240 V/13A No Charge

Option A3 Australian 240 V/10A No Charge

Option A4 North American 240 V/15A No Charge

For Recommended Cameras — See Camera section, page 316.

5A14N

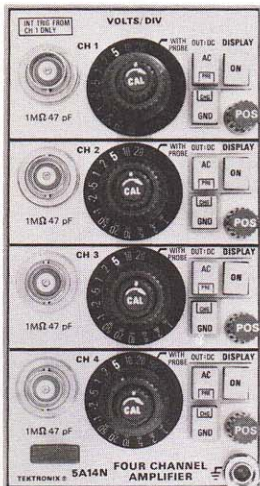

Four Trace Dc to 1 MHz

5A14N Amplifier

1 mV/div to 5 V/div

The 5A14N Four Trace Amplifier features simplified front-panel controls and can be used in any 5000 Series Mainframe.

5A14N operating modes are: each channel separately, and alternated or chopped between any combination of channels. Internal trigger is available from channel one only.

CHARACTERISTICS

Bandwidth — Dc coupled, dc to at least 1 MHz at all deflection factors. Ac coupled, 2 Hz or less to at least 1 MHz at all deflection factors.

Deflection Factor — 1 mV/div to 5 V/div to 12 calibrated steps (1-2-5 sequence). Accuracy is within 2%. Uncalibrated, continuously variable between calibrated steps and 12.5 V/div.

Input R and C — 1 MΩ within 1%, ≈47 pF.

Max Input — Dc coupled, 350 V (dc + peak ac). Ac coupled, 350 V dc.

Chopping Rate — 25 kHz to 100 kHz depending upon plug-in combinations and number of traces displayed.

5A15N

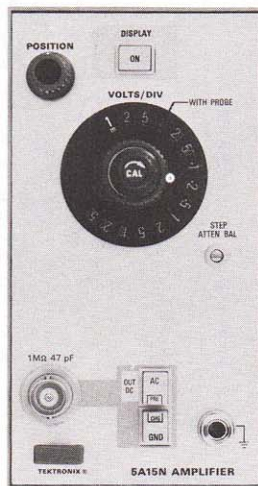

Single Trace Dc to 2 MHz

5A15N Amplifier

1 mV/div to 5 V/div

The 5A15N Single Trace Amplifier features easy to use front-panel controls and can be used in many 5000 Series Mainframe.

Two 5A15Ns (one must be located in the right-hand compartment) provide versatile X-Y operation when used in a 5100 Series Mainframe.

CHARACTERISTICS

Bandwidth — Dc coupled, dc to at least 1 MHz at all deflection factors. Ac coupled, 2 Hz or less to at least 2 MHz at all deflection factors.

Deflection Factor — 1 mV/div to 5 V/div in 12 calibrated steps (1-2-5 sequence). Accuracy is within 2%. Uncalibrated, continuously variable between calibrated steps and to 12.5 V/div.

Input R and C — 1 MΩ within 1%, ≈47 pF.

Max Input — Dc coupled, 350 V (dc + peak ac). Ac coupled, 350 V dc.

5A24N

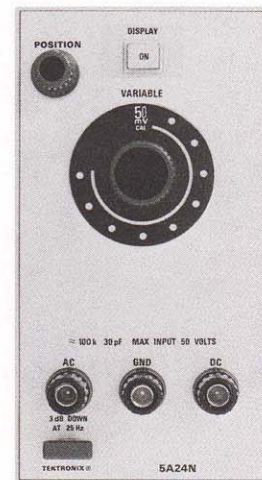

Single Trace Dc to 2 MHz

5A24N Amplifier

50 mV/div to 1 V/div Deflection Factors

Easy to Customize

The 5A24N is a low cost utility plug-in providing direct access to either the vertical or horizontal deflection system of the 5000 Series Mainframes. It contains mode switching, CRT beam positioning, trigger pickoff for basic measurements, and a built-in 3 3/8 x 2 3/4 inch soldering pad matrix for use by the customers who wish to build their own input circuits for special applications. Customer-built circuits are powered through the circuit board which provides access to all mainframe power supplies.

CHARACTERISTICS

Bandwidth — Dc coupled, dc to at least 2 MHz at 50 mV/div, decreasing to dc to 200 kHz at mid-attenuator range. Ac coupled, 25 Hz to at least 2 MHz at 50 mV/div, decreasing to 25 Hz to 200 kHz at mid-attenuator range. Uncompensated input.

Deflection Factor — 50 mV/div, accurate within 3%. Continuously variable, uncalibrated from 50 mV/div to at least 1 V/div.

Input R and C — ≈100 kΩ, ≈30 pF.

Max Input — 50 volts (dc + peak ac).

ORDERING INFORMATION

| | |
|---|---------------|
| 5A14N Four Trace Amplifier | \$1270 |
| 5A15N Single Trace Amplifier | \$300 |
| 5A24N Single Trace Amplifier | \$160 |

5A18N

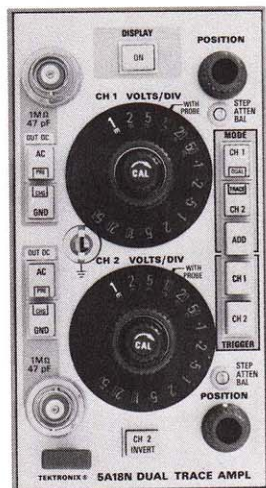

Dual Trace Dc to 2 MHz

5A18N Amplifier

1 mV/div to 5 V/div

The 5A18N Dual Trace Amplifier features easy to use front-panel controls and can be used in any 5000 Series Mainframe.

5A18N operating modes include channel one or two only, channels one and two added, channel two inverted and channel one alternated or chopped with channel two. Internal trigger source is selectable from channel one and channel two.

CHARACTERISTICS

Bandwidth — Dc coupled, dc to at least 2 MHz at all deflection factors. Ac coupled, 2 Hz or less to at least 2 MHz at all deflection factors.

Deflection Factor — 1 mV/div to 5 V/div in 12 calibrated steps (1-2-5 sequence). Accuracy is within 2%. Uncalibrated, continuously variable between calibrated steps and to 12.5 V/div.

Input R and C — 1 MΩ within 1% ≈ 47 pF.

Max Input — Dc coupled, 350 V (dc + peak ac). Ac coupled, 350 V dc.

Chopping Rate — 25 kHz to 100 kHz to 100 kHz depending upon plug-in combinations and number of traces displayed.

Order 5A18N Dual Trace Amplifier \$630

5D10

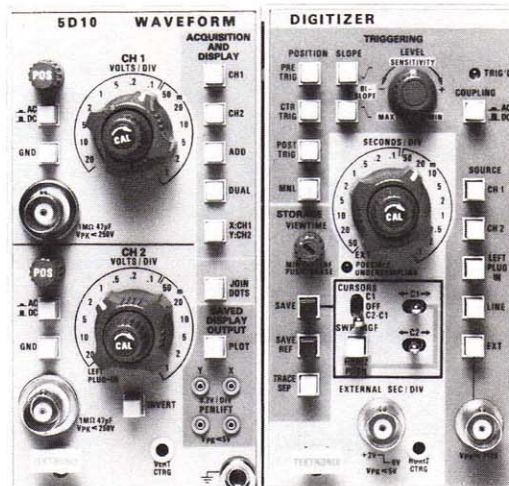

Waveform Digitizer



5D10 Waveform Digitizer

Dual Channel Digital Waveform Storage

CRT Scale Factor Readout

Two Cursors for Point to Point Measurements

Pre-Trigger Viewing

Roll Mode

X-Y Display

Analog Plotter Output

The 5D10 is a double wide plug-in waveform digitizer designed to enhance the capabilities of the 5110. It may be used in other 5000 Series Mainframes. The 5D10 provides digital storage and generates its own readout of scale factors and cursor coordinate values. It will digitize two channels simultaneously with high vertical and horizontal resolution. When inserted into the 5110, the vacant left vertical compartment may be used with one of several plug-ins to precondition the signal for the 5D10. Such a case might be the 5A26 Dual Differential Plug-in.

Be one of the first to have further information on the 5D10. Fill out and return the 5D10 information request card in this catalog. We will send you complete product information as soon as it is available. Expected product availability is second quarter 1982.

5A13N

Dc to 2 MHz Bandwidth

1 mV/div to 5 V/div

10,000:1 Cmrr

10,000 Div Effective Screen Height

The 5A13N is a differential comparator plug-in amplifier for the 5000 Series. It incorporates a number of performance features that make it particularly versatile.

Conventional Mode — The 5A13N has constant bandwidth over the 1 mV/div to 5 V/div deflection factor range. The bandwidth is selectable at 2 MHz or 10 kHz for best displayed noise conditions during low-frequency applications. The plus or minus inputs allow normal or inverted displays.

Differential Mode — The 5A13N maintains its conventional features and provides a balanced input for applications requiring rejection of a common-mode signal. The cmrr is 10,000:1 from dc to 20 kHz, decreasing to 100:1 at 2 MHz. The unit rejects up to 15 V of common-mode signal at a deflection factor setting of 1 mV/div, increasing to 350 V rejection capability above 100 mV/div.

Comparator Mode — The 5A13N provides an accurate positive or negative internal offsetting voltage. A signal of up to ±10 V may be applied to an input (plus or minus) at a deflection factor setting of 1 mV/div and viewed in 10,000 div by offsetting the signal with the opposing comparison voltage. A ±1 V comparison voltage is also available for applications requiring max resolution. The offset voltage may be externally monitored through a front-panel output.

CHARACTERISTICS

Bandwidth — Dc to 2 MHz. Bandwidth limit mode, dc to 10 kHz. Ac coupled, 2 Hz or less at the lower -3 dB point.

Deflection Factor — 1 mV/div to 5 V/div in a 1-2-5 sequence. Accuracy is within 3%. Uncalibrated, continuously variable between steps and to at least 12.5 V/div.

Input R and C — 1 MΩ, ≈51 pF.

Signal Range

| | | |
|--|-------------------|------------------|
| Deflection Factor Settings | 1 mV to 50 mV/div | 0.1 V to 5 V/div |
| Common-Mode Signal Range | ±10 V | ±350 V |
| Max Dc Coupled Input (Dc + Peak Ac at 1 kHz or Less) | ±350 V | |
| Max Ac Coupled Input (Dc Voltage) | ±350 V | |

Max Input Gate Current — 0.1 nA or less (equivalent to 100 μV or less, depending on external loading) at 25°C.

Overdrive Recovery — 1 μs to recover to within 3.0 mV and 0.1 ms to recover to within 1.5 mV after removal of an overdrive signal between +10 V and -10 V, regardless of overdrive signal duration.

Internal Comparison Voltage — Ranges, 0 V to ±10 V and 0 V to ±1 V. Accuracy, within 0.2% of dial setting plus 5 mV from ±1 V to ±10 V; within 0.2% of dial setting plus 1 mV from ±25 mV to ±1 V on the 0 V to ±1 V range. From 0 V to ±25 mV, use the on-screen display for greater resolution. Vc output R, ≈15 kΩ.

Common-Mode Rejection Ratio — At least 10,000:1, dc to 10 kHz at 1 mV/div to 50 mV/div dc coupled, with up to 20 V p-p sinewave, decreasing to 100:1 at 1 MHz. At least 400:1, dc to 10 kHz at 0.1 V/div to 5 V/div dc coupled, with up to 100 V p-p sinewave, decreasing to 40:1 at 1 MHz. For frequencies above 5 kHz ac coupled, cmrr is the same as stated for dc coupled. Below 5 kHz ac coupled, cmrr decreases to 400:1 at 10 Hz. Cmrr with two P6060 Probes is at least 400:1 at any deflection factor.

5A13N

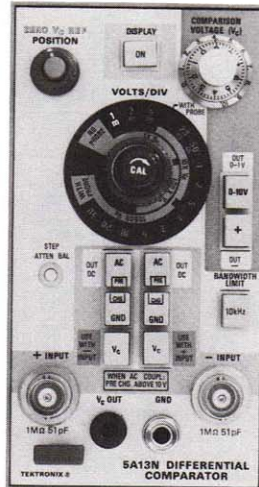

Differential Comparator

5A21N

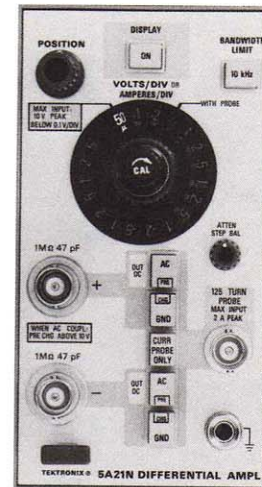

Differential

5A19N

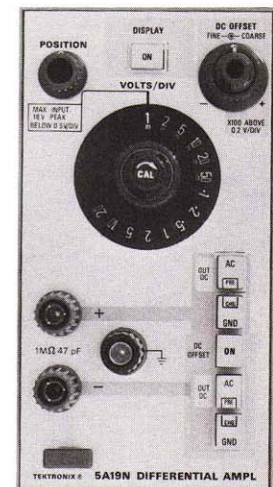

Differential

5A21N

Dc to 1 MHz Bandwidth

10 kHz Bandwidth Limiter

50 μV/div to 5 V/div

100,000:1 Cmrr

Voltage and Current Probe Inputs

The 5A21N is a 50 μV/div, dc coupled differential amplifier for the 5000 Series. The 5A21N has a current probe input.

High Cmrr Probes for Differential Amplifiers We recommend the P6055 high cmrr adjustable 10X probes for use with Tektronix differential amplifiers.

When used in pairs, these probes increase the differential input impedance to 20 MΩ and allow adjustment for maximum common-mode rejection ratio (cmrr).

See page 336 for P6055 characteristics.

VOLTAGE CHARACTERISTICS

Bandwidth — Dc coupled, dc to at least 1 MHz. Ac coupled, 2 Hz less at least 1 MHz. Bandwidth may be limited to 10 kHz.

Deflection Factor — 50 μV/div to 5 V/div in 16 calibrated steps (1-2-5 seq). Accuracy is within 2%. Uncalibrated, continuously variable between calibrated steps and to 12.5 V/div.

Input R and C — Voltage mode, 1 MΩ within 0.15%, ≈47 pF.

Max Input Voltage

| | | |
|------------------------|----------------------|---|
| | Dc Coupled | Ac Coupled |
| 50 μV/div to 50 mV/div | 10 V (dc + peak ac) | 350 V dc (coupling cap pre-charged), 10 V peak ac |
| 100 mV/div to 5 V/div | 350 V (dc + peak ac) | |

Input Gate Current — 100 pA or less (equivalent to 100 μV or less, depending on external loading, at 25°C).

Displayed Noise — 30 μV or less, tangentially measured.

Common-Mode Rejection Ratio — Ac coupled, 50 μV/div to 0.5 mV/div, at least 20,000:1 at 5 kHz and above decreasing to 400:1 at 10 Hz. Dc coupled, at least 100,000:1 dc to 30 kHz at 50 μV/div and 100 μV/div with up to 20 V p-p sinewave, decreasing by <20 dB/decade on sensitivity ranges up to 50 mV/div. From 100 mV/div to 5 V/div, cmrr is at least 400:1 with up to 100 V p-p sinewave. Cmrr with two P6060 Probes is at least 400:1 at any deflection factor.

CURRENT PROBE INPUT CHARACTERISTICS

(with P6021 CURRENT PROBE)

Bandwidth — 15 Hz or less, to at least 1 MHz. Bandwidth may be limited to 10 kHz.

Deflection Factor — 0.5 mA/div to 0.5 A/div in 10 calibrated steps (1-2-5 sequence). Accurate within 3%. Uncalibrated, continuously variable between steps and to 1.25 A/div.

Max Input Current — 4 A p-p (at probe loop) with 125-turn P6021 Current Probe.

Displayed Noise — 300 μA or less, tangentially measured. Performance characteristics are valid for the 5A21N from 0°C to +50°C.

5A19N

Dc to 2 MHz Bandwidth

1 mV/div to 20 V/div

Dc Offset

The 5A19N is a low-cost differential amplifier featuring variable dc offset and simplicity of controls. It is ideal for monitor and systems applications. It operates in the left or middle plug-in compartment of the 5000 Series Mainframe for Y-T displays, or in the right compartment for X-Y displays.

CHARACTERISTICS

Bandwidth — Dc coupled, dc to at least 2 MHz at all deflection factors. Ac coupled, 2 Hz or less to at least 2 MHz at all deflection factors.

Deflection Factor — 1 mV/div to 20 V/div in a 1-2-5 sequence. Accuracy is within 2%. Uncalibrated, continuously variable between calibrated steps and to 50 V/div.

Input R and C — 1 MΩ within 0.3%, ≈47 pF.

Signal and Offset Range

| | | |
|--|------------------------|------------------------|
| Deflection Factor Settings | 1 mV/div to 200 mV/div | 500 mV/div to 20 V/div |
| Common-Mode Signal Range | ±16 V | ±350 V |
| Max Dc Coupled Input (Dc + Peak Ac at 1 kHz or Less) | ±350 V | |
| Max Ac Coupled Input (Ac Voltage) | ±350 V | |
| Dc Offset Range | +15 V to -15 V | +350 V to -350 V |

Common-Mode Rejection Ratio — Dc coupled, 1 mV/div to 200 mV/div, at least 1000:1 from dc to 10 kHz; decreasing to 100:1 at 500 mV/div to 20 V/div.

ORDERING INFORMATION

| | |
|--|------------------|
| 5A13N Differential Comparator Amplifier | \$1140 |
| 5A19N Differential Amplifier | \$375 |
| 5A21N Differential Amplifier | \$465 |
| Option 01 (includes P6021, 5 ft current probe) | Add \$265 |

The 5A21N and 5A22N Differential Amplifiers are available with CRT readout at additional cost (CRT readout functional in 5400 Series Mainframes only). Contact your local Tektronix Sales Engineer for details.

5A22N

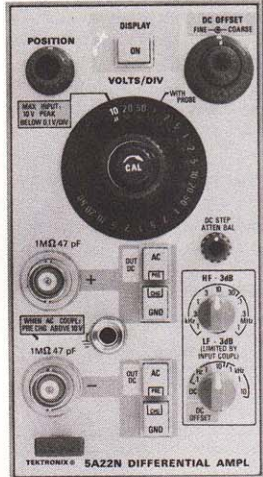

Differential

5A22N

Dc to 1 MHz Bandwidth

10 μ V/div to 5 V/div

100,000:1 Cmrr

Selectable Upper and Lower -3 dB Points

Dc Offset

The 5A22N is the most versatile of the 5000 Series Differential Amplifiers. It features front panel selectable filtering which enables reduction of undesirable displayed noise; both upper and lower 3 dB points are selectable. Dc offset at full bandwidth is available for viewing signals riding on a dc component such as low-level ripple and noise on a power supply.

These features, together with its high common-mode rejection, make the 5A22N well suited for measurements in difficult low-amplitude, low-frequency areas.

CHARACTERISTICS

Bandwidth — HF -3 dB point: selectable in 9 steps (1-3 sequence) from 100 Hz to 1 MHz. 100 Hz to 0.3 MHz, accurate to within 20% of selected frequency; at 1 MHz, bandwidth is down 3 dB or less. LF -3 dB point: selectable in 6 steps (1-10 sequence) from 0.1 Hz to 10 kHz accurate to within 20% of selected frequency. Ac coupled, 2 Hz or less.

Deflection Factor — 10 μ V/div to 5 V/div in a 1-2-5 sequence. Accuracy is within 3%. Uncalibrated, continuously variable between steps and to at least 12.5 V/div.

Common-Mode Rejection Ratio — Ac coupled, 10 μ V/div to 0.5 mV/div, at least 20,000:1 at 5 kHz and above, decreasing to 400:1 at 10 Hz. Dc coupled, at least 100,000:1, dc to 30 kHz from 10 μ V/div to 100 μ V/div with up to 20 V p-p sine wave, decreasing by <20 dB/decade on sensitivity ranges up to 50 mV/div. From 100 mV/div to 5 V/div, cmrr is at least 400:1 with up to 100 V p-p sine wave. Cmrr with two P6060 Probes is at least 400:1 at any deflection factor.

5A26

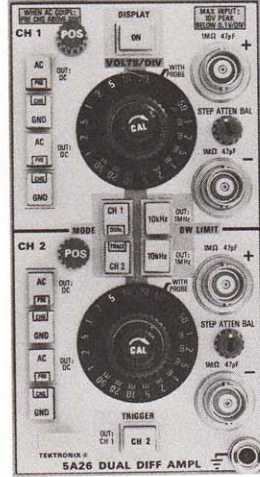

Dual Differential

Signal and Offset Range

| | | |
|--|-------------------------|--|
| Deflection Factor Settings | 10 μ V to 50 mV/div | 0.1 V to 5 V/div |
| Common-Mode Signal Range | \pm 10 V | \pm 350 V |
| Max Dc Coupled Input (Dc + Peak Ac at 1 kHz or Less) | \pm 12 V | \pm 350 V |
| Max Ac Coupled Input (Dc Voltage) | \pm 350 V | Dc rejection, at least $4 \times 10^5:1$ |
| Dc Offset Range | +0.5 V to -0.5 V | +50 V to -50 V |

Input R and C — 1 M Ω within 0.15%, \approx 47 pF.

Overdrive Recovery — 10 μ s or less to recover within 99.5% of reference level after removal of a test signal applied for 1 s. Signal amplitude not to exceed common-mode signal range.

Max Input Gate Current — 200 pA or less.

Displayed Noise — 20 μ V at max bandwidth, source resistance 25 Ω or less, measured tangentially.

Drift with Temperature — 100 μ V/ $^{\circ}$ C or less.

5A26

Two Differential Amplifiers in One Plug-In

50 μ V/div Sensitivity at 1 MHz

100,000:1 Cmrr

CRT Readout

The 5A26 Dual Differential Amplifier combines two independent differential amplifiers in one plug-in. It adds no-compromise differential measurement capability to the line of low-cost, high-performance 5000 Series Laboratory Oscilloscopes. It may be used in any 5000 Series Mainframe.

The 5A26 provides 50 μ V/div sensitivity at 1 MHz, high common-mode rejection ratio, CRT readout in any standard 5400 Series Mainframe, trigger-source selection and bandwidth limit on each channel. With two 5A26s, it is possible to observe up to four differential channels at one time in the chop or alternate mode.

The 5A26 has many applications in areas that require dual differential performance, especially in biomedical and electromechanical fields, education, and component manufacturing.

High Cmrr Probes for Differential Amplifiers

We recommend the P6055 high cmrr adjustable 10X probes for use with Tektronix differential amplifiers.

When used in pairs, these probes increase the differential input impedance to 20 M Ω and allow adjustment for maximum common-mode rejection ratio (cmrr).

See page 336 for P6055 characteristics.

CHARACTERISTICS

Number of Differential Channels — Two.

Bandwidth — Dc coupled, dc to at least 1 MHz. Ac coupled, 2 Hz or less to at least 1 MHz. Bandwidth may be limited to 10 kHz.

Deflection Factor — 50 μ V/div to 5 V/div in 16 calibrated steps (1-2-5 sequence). Accuracy is within 2%. Uncalibrated, continuously variable between calibrated steps and to 12.5 V/div.

CRT Readout — CRT readout of deflection factors. Functional in CRT readout-equipped 5400 Series Oscilloscopes, nonfunctional in 5100 Series Oscilloscopes.

Input R and C — 1 M Ω within 0.15% paralleled by \approx 47 pF.

| | Max Input Voltage | |
|-----------------------------|----------------------|--|
| | Dc Coupled | Ac Coupled |
| 50 μ V/div to 50 mV/div | 10 V (dc + peak ac) | 350 V dc (coupling cap precharged), 10 V peak ac |
| 100 mV/div to 5 V/div | 350 V (dc + peak ac) | 350 V (dc + peak ac) |

Input Gate Current — 100 pA or less (equivalent to 100 μ V or less, depending on external loading) at 25 $^{\circ}$ C.

Displayed Noise — 30 μ V or less, tangentially measured.

Common-Mode Rejection Ratio

| | |
|---|---|
| Dc Coupled 50 μ V/div to 50 mV/div | At least 100,000:1 from dc to 30 kHz with up to 20 V p-p sine wave |
| 100 mV/div to 5 V/div | At least 300:1 from dc to 30 kHz with up to 100 V p-p sine wave |
| Ac Coupled 50 μ V/div to 50 mV/div | At least 20,000:1 at 5 kHz to 30 kHz, decreasing to not less than 2000:1 at 60 Hz |
| With 2 P6062A Probes | 400:1 at 10X probe attenuation |

ORDERING INFORMATION

5A22N Differential Amplifier \$940

5A26 Dual Differential Amplifier \$1010

5B10N

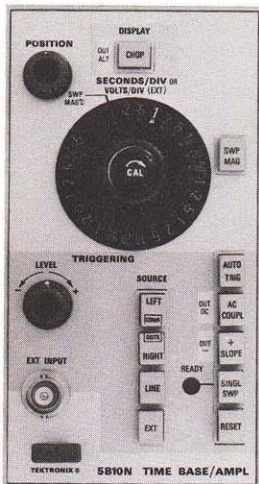

Single Sweep Time Base
5B10N

100 ns/div to 5 s/div Calibrated Time Base

Single Sweep

Direct Readout X10 MAG

Provides Alternate and Chopped Displays

50 mV/div and 500 mV/div External Input

The 5B10N is a time base/amplifier plug-in unit for generating a sweep in the 5000 Series Oscilloscopes. An external input allows use of the 5B10N as a voltage amplifier with calibrated deflection factors of 50 mV/div and 500 mV/div.

Multiple triggering modes may be pushbutton selected with the 5B10N. Source positions include left or right plug-in, composite (from the mainframe vertical amplifier), line and external.

CHARACTERISTICS

Sweep Rates — 1 μ s/div to 5 s/div in 21 calibrated steps (1-2-5 sequence). X10 magnifier extends displayed sweep time/div to 100 ns. Uncalibrated, continuously variable between steps and to 12.5 s/div.

Sweep Accuracy — Unmagnified, within 3% from 1 μ s/div to 1 s/div and within 4% of 2 s/div and 5 s/div. Magnified displays accurate within 1% in addition to specified time base sweep accuracy.

| TRIGGERING | | | |
|------------|-----------------------------------|----------|----------|
| | Coupling | To 1 MHz | At 2 MHz |
| Dc | Internal | 0.4 div | 0.6 div |
| | External* | 200 mV | 200 mV |
| Ac | Requirements increase below 50 Hz | | |

Auto Trig — Same as above except signal rate requirements are 15 Hz and above.

Single Sweep — Same as for ac and dc coupled.

External Trigger Input — Max input is 350 V (dc + peak ac). Input R and C is 1 M Ω within 2% paralleled by \approx 70 pF. Trigger level voltage range is +5 V to -5 V.

EXTERNAL HORIZONTAL MODE

Deflection Factor — 50 mV/div and 500 mV/div, accurate within 3%. X10 variable extends range to at least 5 V/div.

Bandwidth — Dc coupled, dc to at least 1 MHz. Ac coupled, 50 Hz or less to at least 1 MHz.

Input R and C — 1 M Ω within 2%, \approx 70 pF.

Max Input Voltage — 350 V (dc + peak ac).

5B12N

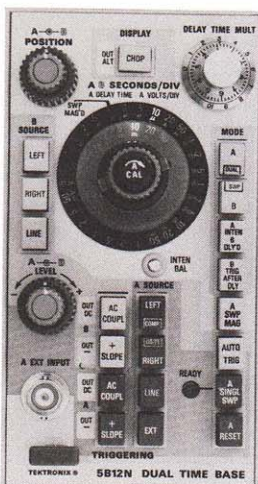

Dual Sweep Time Base
5B12N

100 ns/div to 5 s/div Calibrated Time Base

Dual and Delayed Sweep

Direct Readout X10 MAG

The 5B12N is a time base for generating single, dual, or delayed sweeps in 5000 Series Oscilloscopes. The 5B12N is normally used in the right plug-in compartment but is compatible with the vertical deflection compartments as well.

The display modes are A sweep, B sweep, A intensified -B delayed, and dual sweep. Each mode is selectable by pushbutton switches. Triggering sources for A and B sweep include left and right plug-in, line, and display composite. In the display composite mode the sweep is triggered from the composite signal being displayed. Auto and external trigger and single sweep are provided for the A sweep. The B sweep is triggerable after the delay time.

When operated in the dual-sweep mode in a dual-beam oscilloscope with two amplifier plug-ins, first the A sweep and then the B sweep displays the signals from both amplifiers; four traces will be displayed. Both sweeps are displayed simultaneously in chop mode.

When operated in the dual-sweep mode in a single-beam oscilloscope with two amplifier plug-ins, the A sweep is slaved to the left plug-in and the B sweep is slaved to the right plug-in.

The display mode pushbutton selects chop or alternate time-share switching between vertical plug-ins and amplifier channels. Chop rate is 25 kHz to 100 kHz depending on plug-in combinations and number of traces displayed.

CHARACTERISTICS

A Sweep Rates — 1 μ s/div to 5 s/div in 21 calibrated steps (1-2-5 sequence). X10 magnifier extends displayed sweep time/div to 100 ns. Uncalibrated, continuously variable between steps and to 12.5 s/div.

A Sweep Accuracy — Unmagnified, within 3% from 1 μ s/div to 1 s/div and within 4% at 2 s/div and 5 s/div. Magnified, displays accurate to within 1% in addition to specified time-base sweep accuracy.

B Sweep Rates — 0.2 μ s/div to 0.5 s/div in 20 calibrated steps.

B Sweep Accuracy — Within 3% from 1 μ s/div to 0.1 s/div. Within 4% at 0.2 μ s/div, and 0.5 s/div, 0.2 s/div, and 0.5 s/div..

TRIGGERING

The following applies to the A and B trigger except as noted.

| | Coupling | To 1 MHz | At 2 MHz |
|----|-----------------------------------|----------|----------|
| Dc | Internal | 0.4 div | 0.6 div |
| | External* | 200 mV | 200 mV |
| Ac | Requirements increase below 50 Hz | | |

*A Trigger only.

B sweep operates in triggered or free-run mode after delay time.

Auto Trig — Same as above on signal rates of 15 Hz and above.

The following characteristics apply to the A trigger only.

Single Sweep — Same as for ac and dc coupled.

External Trigger Input — Max input voltage is 350 V (dc + peak ac). Input R and C is 1 M Ω within 2% paralleled by \approx 70 pF. Trigger level voltage range is +5 V to -5 V.

DELAYING SWEEP CHARACTERISTICS

Delay Time Accuracy — 1 μ s/div to 0.5 s/div, within 1%. 1 s/div to 5 s/div, within 2%.

Delay Time Multiplier Range — 0.2 to 10.2 times the time/div setting.

Delay Time Multiplier Incremental Linearity — Within 0.2%.

Differential Time Measurement Accuracy — Within 1% plus 2 minor dial div for 1 μ s to 0.5 s delay times. Within 2% plus 2 minor dial div for 1 s to 5 s delay times.

Jitter — $<$ 0.05% of the time represented by one div of the delaying sweep selected.

EXTERNAL HORIZONTAL MODE

Deflection Factor — 50 mV/div and 500 mV/div accurate to within 3%. X10 variable extends range to at least 5 V/div.

Bandwidth — Dc coupled, dc to at least 1 MHz. Ac coupled, 50 Hz or less to at least 1 MHz.

Input R and C — 1 M Ω within 2%, \approx 70 pF.

Max Input Voltage — 350 V (dc + peak ac).

ORDERING INFORMATION

| | |
|---------------------------------|-------|
| 5B10N Time Base/Amplifier | \$460 |
| 5B12N Dual Time Base | \$970 |

5CT1N

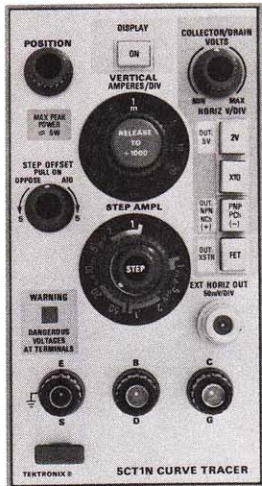

Curve Tracer

5L4N

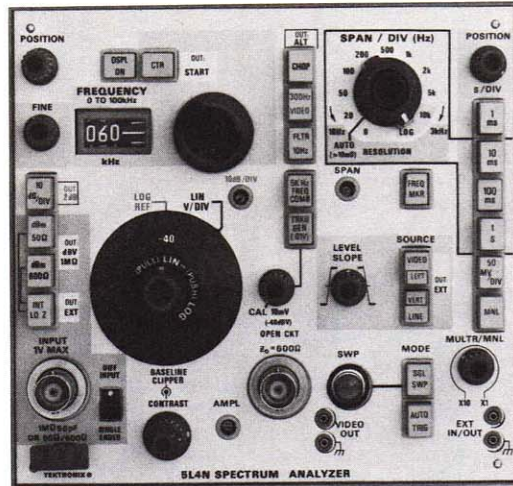

Spectrum Analyzer

5S14N

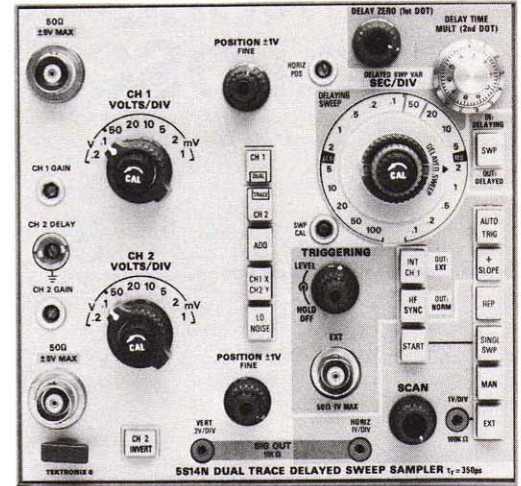

Dual Trace Delayed Sweep Sampler

5CT1N Curve Tracer

- Test Semiconductor Devices to 0.5 W • 10 nA/div to 20 mA/div Vertical Deflection Factors • 0.5 V/div to 20 V/div Horizontal Deflection Factors
- For a complete description see page 309.

5L14N Spectrum Analyzer

- Low Cost • 0-100 kHz Frequency Range
- Resolution Bandwidth 10 Hz to 3 kHz • Log and Linear-Span Modes • Auto Resolution • For a complete description see page 131.

5S14N Sampler

- Dc to 1 GHz Bandwidth
- Dual Trace, 2 mV/div Sensitivity
- Calibrated Delayed Sweep
- Simplified Triggering
- Operational Ease of Conventional Oscilloscope
- Two-Dot Time Measurements

The 5S14N Sampling Unit combines amplifier and time-base functions in one double-width plug-in unit designed to operate in all 5000 Series Mainframes. Combining the sampling amplifier and time-base functions in one plug-in enables the 5S14N to provide new economy and ease of operation.

Two identical amplifier channels provide dual-trace sampling. A two-ramp time base introduces calibrated delayed sweep operation to sampling in an inexpensive package.

A unique feature is a system for making two-dot time-interval measurements. This feature provides an easy and accurate means for measuring the time between two points on a waveform. One bright dot on the trace is positioned with the Delay Zero control to the start of an event to be measured. Next a second bright dot is positioned

by the Delay Time Multiplier Control to the end of the event. The time-interval between the selected points is then determined by multiplying the number read directly from the Delay Time Multiplier Dial by the selected time per division.

AMPLIFIER CHARACTERISTICS

Modes — Channel 1 only; Channel 2 only; Dual Trace; Channel 1 added to channel 2; Channel 2 subtracted from Channel 1 (CH 2 INVERT); Channel 1 vertical (Y), Channel 2 horizontal (X).

Input Impedance — Nominally 50 Ω .

Bandwidth — Equivalent to dc to 1 GHz.

Rise Time — 350 ps or less.

Step Aberrations — +2%, -3%, total of 5% p-p within first 5 ns, $\pm 1\%$ thereafter, tested with 284 Pulse Generator.

Deflection Factor — 2 mV/div to 0.5 V/div in 8 calibrated steps (1-2-5 sequence). Variable between steps by at least 2.5 to 1.

Accuracy — Within $\pm 3\%$.

Max Input Voltage — $\pm 5V$.

Input Signal Range — 2 V p-p max within a +2 V to -2 V window at any sensitivity.

Dc Offset Range — At least +2 V to -2 V.

Displayed Noise — 2 mV or less unsmoothed (tangentially measured). Low noise pushbutton reduces random noise by factor of 4 to 1 or more.

Vertical Signal Output — 0.2 V/div of vertical deflection; 10 k Ω source resistance.

Channel Delay Difference — Adjustable to zero or for any time difference up to at least 1 ns.

TIME BASE CHARACTERISTICS

Scan Modes — Repetitive, Single, Manual, or External.

Delayed Sweep — May be used as CRT time base or as a delay generator for the Delayed Sweep. The sweep starts with minimum delay from the instant of trigger recognition. When the Delaying Sweep mode is selected for the time base, two bright dots in the trace are generated which may be positioned anywhere on the displayed waveform. The time between dots is equal to the reading on the Delay Time Multiplier dial multiplied by the time/div.

Delayed Sweep — This mode is used when the signal to be displayed occurs considerably later than the instant of trigger recognition or when the time must be 5 ns or less per div. The Delayed Sweep may be started with zero delay time with respect to the start of the Delaying Sweep. Or the start may be delayed by any time interval up to that represented by ten div of the Delaying Sweep selected.

Horizontal Signal Output — 1.0 V per div of horizontal deflection; 10 k Ω source resistance.

DELAYING SWEEP CHARACTERISTICS

Range — 10 ns/div to 100 μ s/div in 13 steps (1-2-5 sequence).

Accuracy — Within $\pm 3\%$ excluding first 1/2 div of displayed sweep.

Delay Zero (1st Dot) — Adjustable to correspond to any instant within the time interval represented by the first 9 div of the Delaying Sweep selected.

Delay Time (2nd Dot) — Adjustable to any portion of the time interval represented by ten div of the Delaying Sweep selected.

Delay Accuracy — Within $\pm 1\%$ of ten div when measurement is made within the last 9.5 div.

DELAYED SWEEP CHARACTERISTICS

Range — 100 ps/div to 100 μ s/div in 19 calibrated steps (1-2-5 sequence). Variable between steps by at least 2.5 to 1.

Accuracy — Within $\pm 3\%$ excluding first 1/2 div of displayed sweep.

Start Delay — Depends on the Delaying Sweep time selected and the setting of the Delay Time Mult dial. Adjustable from Zero to any time interval up to that represented by 10 div of the Delaying Sweep selected. The Delaying Sweep start point corresponds to the second bright dot position.

Delay Jitter — $< 0.05\%$ of the time represented by 1 div of the Delaying Sweep selected.

TRIGGERING AND SYNC CHARACTERISTICS

Signal Source — Interval from Channel 1 vertical input or external through front-panel connector.

External Triggering — Nominal 50 Ω input, ac coupled, 2 V p-p, 50 V dc max. Trigger pulse amplitude 10 mV p-p or more with rise time of 1 μ s or less. 10 Hz to 100 MHz. Sinewave amplitude 10 mV p-p or more from 150 kHz to 100 MHz.

Internal Triggering — Pulse amplitude 50 mV p-p or more with rise time of 1 μ s or less. Sinewave amplitude 50 mV p-p or more from 150 kHz to 100 MHz.

Triggered Mode — Trigger recognition may be made to occur at any selected voltage level between +0.5 V and -0.5 V at instants when either a + slope or a - slope of the triggering signal crosses that level.

Auto Triggered Mode — For small signals or when there may be no triggering signal. Sampling pulses are automatically generated at a low rate in the absence of a triggering signal so a trace may always be generated and displayed. The trigger level range automatically adjusts to approximate the p-p voltage of the signal.

Holdoff — Varies the length of the time interval during which recognition is inhibited. Variation is at least 5 to 1. The control is particularly useful for displaying digital words when triggering on binary pulses.

HF SYNC Mode — For sinewaves from 100 MHz to 1 GHz, 10 mV p-p or more from external source, 50 mV p-p or more from internal pickoff.

Order 5S14N Sampler \$4915

PORTABLE OSCILLOSCOPES

CONTENTS

| | |
|---|-----|
| 2335 100 MHz Dual Trace | 223 |
| 2336 100 MHz Dual Trace w/ Δ Time | 224 |
| 2337 100 MHz Dual Trace w/ Δ Time & DMM | 225 |
| 2213 60 MHz Dual Trace | 226 |
| 2215 60 MHz Dual Trace, Alternate Time Base | 226 |
| 485 350 MHz Dual Trace | 228 |
| 475/475A 250 MHz and 200 MHz Dual Trace | 230 |
| 465B/DMM44 100 Dual Trace | 232 |
| 465M (AN/USM) 425 (V1) 100 MHz Dual Trace Tri-service Standard | 234 |
| 335 35 MHz Dual Trace | 236 |
| 305 Battery Powered 5 MHz/DMM | 237 |
| 221 5 MHz | 238 |
| 213 1 MHz/DMM | 239 |
| 212 500 kHz Dual Trace | 240 |
| T922R 15 MHz Dual Trace Rackmount | 241 |
| Portable Storage Oscilloscopes | |
| 468 100 MHz Dual Trace Digital Storage | 242 |
| 466/464 100 MHz Dual Trace | 244 |
| 434 25 MHz Dual Trace | 246 |
| 314 10 MHz Dual Trace | 247 |
| 214 500 kHz Dual Trace | 248 |
| T912 10 MHz Dual Trace | 249 |

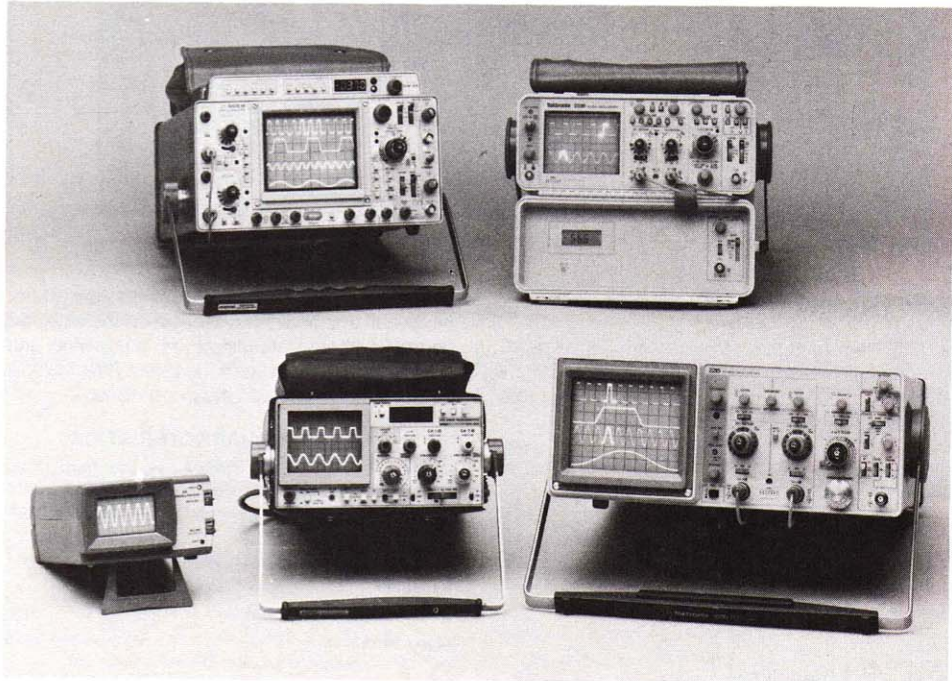

For Accuracy and Versatility in the Field, Take One of Our 23 Portable Oscilloscopes.

| | Product | Bw | Dual Trace | Delayed Sweep | Fastest Sweep | Special Features | Price* |
|-------------------|----------------|---------------------|--------------------|---------------|-----------------|--|------------------------|
| Nonstorage Models | 2335 | 100 MHz @ 5 mV/div | yes | yes | 5 ns/div | Rugged, compact, lightweight | \$2775 |
| | 2336 | 100 MHz @ 5 mV/div | yes | yes | 5 ns/div | B trigger, Δ Time | 3075 |
| | 2337 | 100 MHz @ 5 mV/div | yes | yes | 5 ns/div | B trigger, Δ Time, DMM | 3350 |
| | 2213 | 60 MHz @ 20 mV/div | yes | yes | 5 ns/div | 2 mV/div @ 50 MHz | 1100 |
| | 2215 | 60 MHz @ 20 mV/div | yes | yes | 5 ns/div | Dual time base, 2 mV/div @ 50 MHz | 1400 |
| | 485 | 350 MHz @ 5 mV/div | yes | yes | 1 ns/div | Widest BW in portable instrument | 6975 |
| | 475A | 250 MHz @ 5 mV/div | yes | yes | 1 ns/div | High performance 250 MHz portable | 4410 |
| | 475 | 200 MHz @ 2 mV/div | yes | yes | 1 ns/div | Highest gain/BW in a portable | 3960 |
| | 465B | 100 MHz @ 5 mV/div | yes | yes | 2 ns/div | Cost effective 100 MHz portable | 2995 |
| | 465M | 100 MHz @ 5 mV/div | yes | yes | 5 ns/div | Triservice standard 100 MHz scope | 3500 |
| | 335 | 35 MHz @ 10 mV/div | yes | yes | 20 ns/div | Only 4.8 kg, 10.5 pounds | 2760 |
| | 305 | 5 MHz @ 5 mV/div | yes | | 0.1 μ s/div | Autoranging DMM | 2120 |
| | 221 | 5 MHz @ 5 mV/div | | | 100 ns/div | Only 1.6 kg, 3.5 pounds | 1600 |
| | 213 | 1 MHz @ 20 mV/div | | | 400 ns/div | DMM/scope at 1.7 kg, 3.7 pounds | 2100 |
| | 212 | 500 kHz @ 10 mV/div | yes | | 1 μ s/div | Battery operation | 1545 |
| | T922R | 15 MHz @ 2 mV/div | yes | | 20 ns/div | Rackmount, front or rear inputs | 1750 |
| | Storage Models | 468 | 100 MHz @ 5 mV/div | yes | yes | 2 ns/div | 10 MHz Digital Storage |
| 466 | | 100 MHz @ 5 mV/div | yes | yes | 5 ns/div | 3000 div/ μ s stored writing speed | 6385 |
| 464 | | 100 MHz @ 5 mV/div | yes | yes | 5 ns/div | 110 div/ μ s stored writing speed | 5165 |
| 434 | | 25 MHz @ 10 mV/div | yes | | 20 ns/div | Split-screen storage | 4400 |
| 314 | | 10 MHz @ 1 mV/div | yes | | 100 ns/div | Only 4.8 kg, 10.5 pounds | 3345 |
| 214 | | 500 kHz @ 10 mV/div | yes | | 1 μ s/div | Only 1.6 kg, 3.5 pounds | 2100 |
| T912 | | 10 MHz @ 2 mV/div | yes | | 50 ns/div | Low-cost bistable storage | 1890 |

*U.S. sales prices are F.O.B. Beaverton, OR. For price and availability outside the United States, please contact the nearest Tektronix Field Office, Distributor or Representative. Prices are subject to change without notice.



NEW

2335/36/37

Dc to 100 MHz Bandwidth

**Vertical Channel Deflections
from 5 mV/div to 5 V/div**

**10X Magnifier to Increase
Sweep Rate to 5 ns/div**

Rugged for Field Service

A new line of Tektronix portable oscilloscopes feature extreme ruggedness to provide dependability in field service applications.

Compact and lightweight for ultra-portability, these oscilloscopes are designed and built for on-site trouble-shooting. The 2335, 2336, and 2337 are useful for high speed logic and digital applications. They feature an innovative and protective flip-top cover that doubles as a front panel with Δ Time on the 2336 and Δ Time/DMM on the 2337 versions. The entire outside case of all three instruments is made of durable, one-piece aluminum and the front panels are coated with scratch resistant plastic. When the flip-tops are latched shut, the entire scope can withstand the abuse and heavy usage of field service environments.

Inside these new oscilloscopes is performance capability to accommodate the wide variety of testing conditions normally encountered by field service personnel. Vertical channels have calibrated deflection factors from 5 mV/div to 5 V/div with a variable gain control to increase the sensitivity to at least 2 mV/div. An internal delay line permits observation of the leading edge of a waveform. Variable sweep speeds range from 0.5 s/div to 50.0 ns/div and a 10X magnifier can increase the sweep rate to 5 ns/div. An auto-trigger mode allows triggering on waveforms with repetitive rates down to approximately 10 Hz. The sweep rate will run freely and provide a base line trace in the absence of an adequate trigger signal.

Many exterior features have been incorporated into these new ultra-portable scopes to make them fast and convenient to use. The CRT produces bright, high resolution traces that are readily visible in most light conditions. The Δ Time/DMM readouts are distinct, backlit LCD for clear viewing in any lighting condition. All knobs and switches have been located in logical groupings to avoid errors and delays during operation. And for the 2336 and 2337 models, Δ Timing and DMM display and controls are in the hinged, flip-top cover.

All three oscilloscopes come with detachable power cord, integral EMI shielding, and an accessories pouch.

The Tektronix 2335, 2336, and 2337 Oscilloscopes have been manufactured to withstand impact shocks of 50 g's, almost twice that of other portable scopes from Tektronix. This ruggedness meets MIL-T-28800, Class 3 environmental requirements for aerospace and military qualification.

ELECTRICAL CHARACTERISTICS

The following electrical characteristics are common to the 2335, 2336, and 2337 Oscilloscopes except where indicated.

VERTICAL DEFLECTION
(Two Identical Channels)

Bandwidth* and Rise Time —

| -15 to +40°C | +40 to +55°C |
|-----------------------------------|-----------------------------------|
| Dc to at least 100 MHz, 3.5 ns | Dc to at least 85 MHz, 4.15 ns |

*Measured at -3 dB point at all deflection factors from a 50- Ω source terminated in 50 Ω .

Lower -3 dB Point (ac coupling and 1X probe) — 10 Hz or less; (10X probe): 1 Hz or less.

Deflection Factor — 5 mV/div to 5 V/div. 1-2-5 sequence, accurate $\pm 3\%$. Uncalibrated, continuously variable between steps and to at least 2 mV/div.

Display Modes — Ch 1, Ch 2, ADD (normal and inverted).

Cmrr — Common-mode rejection ratio at least 10:1 at 50 MHz for common-mode signals of 6 div or less.

Input R and C — 1 M Ω $\pm 2\%$ paralleled by 20 pF $\pm 10\%$.

Max Input Voltage — Ac or dc coupled, 400 V (dc + peak ac) or 500 V p-p ac at 1 kHz or less.

HORIZONTAL DEFLECTION

Time Base A — 0.05 μ s/div to 0.5 s/div (1-2-5 sequence). X10 mag extends max sweep rate to 5 ns/div.

Time Base B — 0.05 μ s/div to 50 ms/div (1-2-5 sequence). X10 mag extends max sweep rate to 5 ns/div.

Variable Time Control — Time base A provides continuously variable uncalibrated sweep rates between steps and to at least 1.25 s/div.

Time Base A and B Accuracy, full 10 div —

| | +20° to +30°C | -15° to +55°C |
|--------------------|---------------|---------------|
| Unmagnified | $\pm 2\%$ | $\pm 3\%$ |
| Magnified | $\pm 3\%$ | $\pm 4\%$ |

Display Modes — A, A intensified by B, B delayed.

CALIBRATED SWEEP DELAY

Delay Time Range — Continuous from 50 ns to at least 5 s after start of delaying sweep.

Differential Time Measurement Accuracy —

| | +15° to +35°C | -15° to +55°C |
|------------------|---------------------------------------|---|
| 2335 | 0.75% +0.015 major dial div | 1.5% +0.015 major dial div |
| 2336/2337 | $\pm 1\%$ of reading ± 1 count | $\pm 2.5\%$ of reading ± 1 count |

Jitter — 1 part or less in 20,000 (0.005%) of 10 times the A SWEEP TIME/DIV setting.

TRIGGERING, A AND B

A Trigger Mode — Normal (sweep runs when triggered). Automatic (sweep runs in absence of a triggering signal and for signals below 30 Hz). Single Sweep (sweep runs once on first triggering event after reset selector is pressed). LED light indicates when sweep is triggered and when single sweep is ready.

Sensitivity and Coupling —

| COUPLING | To 20 MHz | At 100 MHz |
|--------------------|------------------------------------|--------------------|
| Internal | 0.3 div deflection | 1.1 div deflection |
| Dc | | |
| External | 50 mV | 150 mV |
| External $\div 10$ | 500 mV | 1.5 V |
| Ac | Requirements increase below 60 Hz | |
| Ac Lf Reject | Requirements increase below 50 kHz | |
| Ac Hf Reject | Requirements increase above 50 kHz | |

A Trigger Hold Off — Adjustable control permits a stable presentation of repetitive waveforms.

Δ TIME B Trigger Modes (2336 and 2337 only) — Provides two intensified zones on the CRT trace for differential time measurements. Time difference between the two intensified zones is determined by B DELAY TIME POSITION and Δ TIME POSITION controls. Time difference is displayed on the LCD readout.

RUNS AFTER DELAY — B sweep starts immediately after the delay time selected by the DELAY TIME POSITION control and is independent of B trigger signal.

TRIGGERABLE AFTER ADJUSTABLE DELAY TIME — The B Sweep Trigger is sourced from a composite of Ch 1 and Ch 2; Ch 1 only or from the EXT Trigger input connector.

Jitter — 1.0 ns or less at 100 MHz and 5 ns/div.

A Trigger View — A spring loaded pushbutton overrides other vertical controls to display the external signal used to trigger the A sweep. This control provides quick verification of the (trigger) signal and permits a time comparison between the vertical input signal and the trigger signal. Deflection Factor is 100 mV/div $\pm 40\%$ (1 V/div with EXT $\div 10$).

Level and Slope — Internal, permits selection of triggering at any point on positive or negative slope of vertical input signal. Level adjustment through at least ± 1 V in external, through at least ± 10 V in external $\div 10$.

Adjustment Range — 1.0 V in EXT (10.0 V in EXT $\div 10$).

A Sources — Vertical Mode, Ch 1, Ch 2, LINE, EXT, EXT $\div 10$.

B Sources (2336 and 2337 only) — Δ Time Runs After Delay, Vertical Mode, Ch 1, Ch 2, EXT (All modes ac coupled).

External Inputs — R and C 1 M Ω $\pm 10\%$, 20 pF $\pm 30\%$, 400 V (dc + peak ac) or 500 V ac p-p at 1 kHz or less.

CALIBRATION SIGNAL

Output Voltage (0° to +40°C) — 0.2 V $\pm 1\%$.

Output Voltage (-15° to +55°C) — 0.2 V $\pm 1.5\%$.

X-Y OPERATION

Full Sensitivity X-Y (Ch 1 Horizontal, Ch 2 Vertical) — 5 mV/div to 5 V/div (1-2-5 sequence), accurate $\pm 5\%$ from 0° to +40°C, accurate $\pm 8\%$ from -15° to +55°C. X-axis bandwidth is dc to at least 2 MHz. Y-axis bandwidth is dc to at least 100 MHz. Phase difference between amplifiers is 3° or less from dc to 200 kHz.

DISPLAY

CRT — 8 X 10 div (8 mm/div) display. Horizontal and vertical centerlines further marked in 0.2 div increments. P31 Phosphor standard. 18 kV accelerating potential.

Graticule — Internal, nonparallax, non-illuminated; markings for measurement of risetime.

Beam Finder — Compresses trace to within graticule area to locate an off screen signal.

Z-Axis Input — Positive-going, dc coupled signal decreases intensity; 5 V p-p signal causes noticeable modulation at normal intensity; dc to 20 MHz.



NEW

DIGITAL MULTIMETER (2337 only)

DC VOLTAGE

Full Scale Ranges — 2V (Auto-ranging to 200 mV); 200 V (auto-ranging to 20 V); and 500 V.

Resolution — 100 μ V at 200 mV full scale.

Accuracy —

| | |
|------------------------|--|
| +15° to +35°C | Within $\pm 0.15\%$ of reading \pm one count |
| -15° to +15°C | Add 0.01% for every °C below +15°C |
| +35° to +55°C | Add $\pm 0.01\%$ for every °C above +35°C |
| >80% Relative Humidity | Add $\pm 0.25\%$ of reading ± 8 counts |

Input Resistance — 10 M Ω $\pm 0.25\%$.

Rejection Ratio — Normal-Mode 60 dB minimum at 50 and 60 Hz. Common-Mode 100 dB minimum at dc, 60 dB minimum at 50 and 60 Hz.

Response Time — Within 3 s (no autorange); within 9 s; (up range); within 7 s; (down range).

Maximum Input Voltage — 500 V (dc + peak ac) at 60 Hz (between positive and negative inputs or between either input and ground).

AC VOLTAGE

Full Scale Ranges — 2 V (auto-ranging to 200 mV); 200 V (auto-ranging to 20 V); and 350 V.

Crest Factor — (When peak voltage input is <3 times full scale) Six.

Accuracy* —

| | |
|---------------|--|
| +15° to +35°C | Within $\pm 3\%$, ± 6 counts, 20 Hz to 20 kHz |
| -15° to +15°C | Add $\pm 0.05\%$ for every °C below +15°C |
| +35° to +55°C | Add $\pm 0.05\%$ for every °C above +35°C |

*Non sinewaves: Derate to 50 Hz to 20 kHz. For crest factors greater than 3, add +0, -1% of reading.

Input Impedance — Resistance 10 M Ω $\pm 0.25\%$. Capacitance (20 V, 200 V, and 350 V range) <150 pF; (200 mV, 2 V range) <220 pF.

Common Mode Rejection Ratio — 60 dB minimum at 50 and 60 Hz, 2 V range; 53 dB minimum at 50 and 60 Hz, 200 V/ and 300 V range.

Response Time — Within 3 s (no autorange); within 9 s; (up range); within 7 s; (down range).

Maximum Input Voltage — 500 V (dc + peak ac) at 60 Hz (between positive and negative inputs or between either input and ground).

RESISTANCE

Full Scale Ranges — 2 k Ω (auto-ranging to 200 Ω); 200 k Ω (auto-ranging to 20 k Ω); 20 M Ω (auto-ranging to 2 M Ω).

Resolution — 0.1 Ω .

Accuracy —

| | |
|------------------------|---|
| +15° to +35°C | Within $\pm 0.5\%$ ± 1 count $\pm 0.4 \Omega$ |
| -15° to +15°C | Add 0.05% for every °C below +15°C |
| +35° to +55°C | Add 0.05% for every °C above +35°C |
| >80% Relative Humidity | Add $\pm 1\%$ of reading ± 8 counts |

Response Time — <4 s.

Maximum Input Voltage — 500 V (dc + peak ac) at 60 Hz (between positive and negative inputs or between either input and ground).



NEW

ENVIRONMENTAL CAPABILITIES*

Operating Temperature Range — -15° to +55°C (forced air ventilation during normal operation).

Storage Temperature Range (2335 only) — -62° to +85°C.

Storage Temperature Range (2336 and 2337) — -40° to +80°C.

Operating Altitude Range — Sea level to 4,500 m (15,000 ft).

Nonoperating Altitude Range — Sea level to 15,000 m (50,000 ft).

Vibration, Structural Integrity — Test samples were subjected to sinusoidal vibration in the X, Y, and Z-axes with the frequency varied from 10 Hz to 55 Hz to 10 Hz in one minute cycles for a duration of fifteen minutes. Total displacement was 0.025 in p-p at 4 g's (55 Hz).

Shock, Operating and Nonoperating — Test samples were subjected to 3 shocks, both directions along each axis (X, Y, and Z) for a total of 18 shocks. Peak acceleration of each shock was 50 g's, 1/2 sine.

Humidity, 2335 only, Operating and Nonoperating — Test samples were exposed to 120 hours (5 cycles) of 95% relative humidity as specified in MIL-T-28800B Paragraph 3.9.2.2.

Humidity, 2336 and 2337 Oscilloscopes, Operating — Test samples were subjected to 90% relative humidity at 55°C for a maximum of 72 hours.

Humidity 2336 and 2337 DMM, Operating — Test samples were subjected to 90% relative humidity at 35°C for a maximum of 24 hours and to 70% relative humidity at 50°C for a maximum of 24 hours.

Humidity 2336 and 2337 Oscilloscope and DMM, Nonoperating — Test samples were subjected to 90% relative humidity at 60°C for 72 hours.

Electromagnetic Interference (EMI) — Test samples were found in compliance with the Class 3 requirements of MIL-STD-461A using procedural steps outlined in MIL-STD-462. (Increase RS03 requirements from 1 V/meter to 10 V/meter).

*The 2335 Oscilloscope meets all environmental requirements of MIL-T-28800, Class 3. The 2336 and 2337 Oscilloscopes meet the environmental requirements of MIL-T-28800, Class 3 except for nonoperating temperature range and high (95-percent) relative humidity, both of which were delimited as indicated herein to avoid potential damage to the LCD readout.

OTHER CHARACTERISTICS

Amplitude Calibrator — 0.2 V accurate ±1% from 0° to +40°C, ±1.5% from -15° to +55°C.

Power Requirements — Quick-change selector for operation from 100 V to 132 Vac or 200 to 250 Vac, 48 to 440 Hz. Maximum power consumption is 60 watts at 132 V, 48 Hz. Typical power consumption is 35 watts at 115 V, 60 Hz. Option 03 provides operation from 90 to 115 Vac or 180 to 230 Vac, 48 to 440 Hz.

| Dimensions | mm | in |
|-------------------------------------|------|------|
| Height (without pouch) | 135 | 5.3 |
| Height (with feet and pouch) | 210 | 8.3 |
| Width | 274 | 10.8 |
| Width (with handle) | 315 | 12.4 |
| Depth (with front cover) | 430 | 17.0 |
| Depth (handle extended) | 527 | 20.8 |
| Weights (2335) | kg | lb |
| Net (without accessories and pouch) | 7.7 | 17 |
| Net (with accessories and pouch) | 8.6 | 19 |
| Shipping | 10.6 | 23.5 |
| Weights (2336 and 2337) | | |
| Net (without accessories and pouch) | 7.9 | 17.5 |
| Net (with accessories and pouch) | 8.8 | 19.5 |
| Shipping | 10.9 | 24.0 |

INCLUDED ACCESSORIES

Two P6108 10X probes (010-6108-03), accessory pouch (016-0674-00), zip lock accessory pouch (016-0537-00), blue CRT light filter (337-2760-00), clear CRT light filter (337-2781-00), two 1A fuses (159-0022-00), 1/2 A fuse (159-0025-00), power cord (161-0104-00). 2337 also includes test lead pair (012-0941-00).

ORDERING INFORMATION

- 2335 Oscilloscope \$2775
- 2336 Oscilloscope with Delta Time ... \$3075
- 2337 Oscilloscope with Delta Time and DMM \$3350

OPTIONS

- Option 03 100/200 V, ac nominal, 48 to 440 Hz No Charge
- INTERNATIONAL POWER CORDS & PLUG OPTIONS**
- Option A1 Universal Euro 220 V/16A No Charge
- Option A2 UK 240 V/13 A No Charge
- Option A3 Australian 240 V/10A No Charge
- Option A4 North American 240 V15 A) No Charge

TEK 60 MHz DUAL TRACE OSCILLOSCOPES



trigger holdoff, TV line and TV field triggering at any sweep speed, and an enhanced auto mode. On the 2215, the dual time base operates in either run after A or trigger after A. The latter permits jitter-free B measurements.

The 2213's single time base delay provides the user with the performance of intensified and delayed sweep operations at a low price. Where dual time base performance is required, the 2215 delivers it with alternate sweep switching. The 2215 can display four traces; vertical channels 1 and 2 at the A sweep rate, and vertical channels 1 and 2, delayed, at the B sweep rate. Both scopes also incorporate new auto-intensity and auto-focus circuits that provide convenient operation over a wide range of sweep speeds.

Low life cycle cost is brought about by the inherent reliability of the new scopes. The parts count and cabling have been greatly reduced as compared to older designs. Even the traditional line transformer and line voltage selector switches have been eliminated, thanks to a new high-efficiency power supply. The advantages of these power supply improvements are that the 2213 and 2215 will operate from mains voltages of 90 to 250 Volts RMS at frequencies from 48 to 62 Hz. Additional reliability also results from superior mechanical design and packaging, soldered-in components, absolute minimum of connectors and very low power consumption.

NEW

2213/2215

Dc to 60 MHz Bandwidth

Light Weight

Easy to Use

2 mV Sensitivity

Advanced Trigger System

5 ns/div Sweep Speed

Delayed Sweep Measurements

Large, Bright CRT

New 10X Probes Included

A pushbutton beamfinder allows easy scope setups. The scope bezel accepts a TEKTRONIX C-5C Scope Camera with graticule illuminating flash (option 04).

The advanced triggering system features true vertical mode alternate triggering; both the 2213 and 2215 will trigger alternately even with unrelated signals. Other features include variable

Two new 60 MHz, dual trace oscilloscopes from Tektronix offer unprecedented value in both initial and life cycle costs. They are ideal everywhere general purpose scopes are needed.

These oscilloscopes provide unexcelled performance in a small light-weight package; 6.1 kilograms (13.5 lb). With pouch and front cover, only 6.8 kilograms (15 lb).

X-Y operation is simple and easy to use. Both vertical input channels (Ch 1 and Ch 2) can be used through their full range of sensitivity settings. Vertical sensitivities range from 2 mV to 10 V/div. Sweep speeds range from 0.5 seconds per division to 50 nanoseconds per division. A 10X magnification provides 5 nanoseconds per division.



CHARACTERISTICS

The following electrical characteristics are common to both instruments except where noted:

VERTICAL DEFLECTION
(2 Identical Channels)

Bandwidth* and Rise Time — (At all deflection factors from 50 Ω terminated source).

| 0°C to +40°C | +40°C to +50°C |
|---|----------------|
| Dc to 60 MHz, 20 mV/div to 10 V/div, 5.8 ns reduced to 50 MHz for 2 mV to 10 mV/div, 7 ns | 50 MHz, 7 ns |

*Measured at -3 dB.

Deflection Factor — 2 mV/div to 10 V/div ±3% (+20°C to +30°C) or ±4% (0°C to +50°C).

1-2-5 sequence. Uncalibrated, continuously variable between steps to at least 25 V/div.

Display Modes — Ch 1, Ch 2, Ch 2 ADD (normal and inverted), alternate, chopped — ≈250 kHz rate, electronically switched.

Cmrr — Common-mode rejection ratio at least 10:1 at 10 MHz for common-mode signals of 6 divisions or less.

Input R and C — 1 MΩ ±2% paralleled by ≈30 pF.

Max Input Voltage —

| | |
|------------|--|
| Dc coupled | 400 V (dc + peak ac) 800 V (p-p ac at 1 kHz or less). |
| Ac coupled | 400 V (dc + peak ac) 800 V (p-p ac at 1 kHz or less). |

Delay Line — Permits viewing leading edge of displayed waveform.

HORIZONTAL DEFLECTION

Time Base A — (Both 2213 and 2215) — 0.05 μs/div to 0.5 s/div (1-2-5 sequence). 10X mag extends max sweep rate to 5 ns/div.

Time Base B — (2215 only) — 0.05 μs/div to 50 ms/div (1-2-5 sequence). 10X mag extends max sweep rate to 5 ns/div.

Variable Time Control — Time Base A (both 2213 and 2215) provides continuously variable uncalibrated sweep rates between steps to at least 1.25 s/div.

Time Base A (both 2213 and 2215) and B (2215 only) Accuracy, center 8 divisions —

| | +20°C to +30°C | 0°C to +50°C |
|-------------|----------------|--------------|
| Unmagnified | ±3% | ±4% |
| Magnified | ±5% | ±6% |

Horizontal Display Modes (2213) — A, A intensified after delay, delayed.

Horizontal Display Modes (2215) — A, alternate (A intensified by B and B), B. Electronic switching between intensified and delayed sweep.

2213 SWEEP DELAY

Delay Times — <0.5 μs, 10 μs, and 0.2 ms.

Multiplier — Increases delay time by 20 to 1 or more.

Jitter — 5000 to 1 (0.02%) of maximum available delay time.

2215 SWEEP DELAY

Delay Times — Continuously variable by means of a 10 to 1 vernier control. Delayed (B) portion is intensified on the main (A) trace.

Delay Position Range — <0.5 to more than 10 divisions.

Delay Dial Accuracy — ±1.5% of full scale.

A/B Sweep Separation — Control permits main and delayed sweep to be separated by at least 3.5 divisions.

Jitter — 10,000 to 1 (0.01%) of maximum available delay time.

TRIGGERING

2213 and 2215 A Time Base Trigger Modes — Normal (sweep runs when triggered), automatic (sweep runs in the absence of a triggering signal and triggers automatically for signals down to 20 Hz), and tv field (with slope set for negative going transitions, and trigger level adjusted close to blanking level, sweep starts at first line of video; use NORMAL for tv line display). LED indicates when sweep is triggered.

A Trigger Holdoff — Adjustable control permits a stable presentation of repetitive complex waveforms.

Sensitivity — Auto and Normal Internal: below 2 MHz, signal must be at least 0.4 divisions amplitude; requirements increase above 2 MHz; at 60 MHz, signal must be at least 1.5 divisions amplitude.

Auto and Normal External — Up to 2 MHz, trigger signal must be at least 50 mV p-p; requirements increase up to 60 MHz, where signal must be at least 250 mV p-p.

TV Field — Composite video must be at least 2 divisions amplitude.

Level and Slope (NORM Mode) — Internal: trigger level can be adjusted over the range of amplitudes displayed on the CRT. External, dc coupled: level can be adjusted over a range of at least ±2 V, or 4 V p-p. External, dc coupled and attenuated (÷ 10): level can be adjusted over a range of at least ±20 V, or 40 V p-p.

External Inputs — R and C ≈ 1 MΩ paralleled by ≈30 pF. 400 V (dc + peak ac) or 800 Vac p-p at 1 kHz or less.

2215 DELAYED (B) TIMEBASE

Level and Slope — Separate slope and level controls for triggering B sweep.

Sensitivity — Up to 2 MHz, signal must be at least 0.4 divisions in vertical amplitude; requirements increase up to 60 MHz, where signal must be at least 2 divisions in amplitude.

X-Y OPERATION

Full Sensitivity X-Y (Ch 1 Horiz, Ch 2 Vert) — 2 mV/div to 10 V/div, accurate ±5%. Bandwidth is dc to at least 2 MHz. Phase difference between amplifiers is 3° or less from dc to 50 kHz.

DISPLAY

CRT — 8 x 10 cm display. Horizontal and vertical center lines further marked in 0.2 cm increments. P31 Phosphor standard. 10 kV accelerating potential, mesh grid, halo suppressed.

Graticule — Internal, non-parallax, not illuminated; markings for measurement of rise time.

Beam Finder — Compresses trace to within graticule area for ease in locating an off-screen signal. A pre-set intensity level provides a constant brightness.

Z-Axis Input — Dc coupled, positive-going signal decreases intensity; 5 V p-p signal causes noticeable modulation at normal intensity; dc to 5 MHz.

ENVIRONMENTAL CAPABILITIES

Ambient Temperature — Operating: 0°C to +50°C. Nonoperating: -55°C to +75°C.

Altitude — Operating: to 15,000 ft; max allowable ambient temperature decreased by 1°C/1000 ft from 5000 to 15,000 ft. Nonoperating: to 50,000 ft.

Vibration — Operating test samples were subjected to sinusoidal vibration in the X, Y, and Z axis with the frequency varied from 10 Hz to 55 Hz to 10 Hz in one minute sweeps for a duration of 15 minutes per axis and a dwell of 10 minutes at 55 Hz. Total displacement was 0.015 in p-p (2.4 g's at 55 Hz).

Humidity — Operating and nonoperating: test samples were subjected to 5 cycles (120 hours) of humidity testing.

Shock — Operating and nonoperating: test samples were subjected to 3 shocks, both directions along each axis for a total of 18 shocks. Peak accelerations of each half-sine shock were 30 g's.

OTHER CHARACTERISTICS

Probe Adjust Signal — Squarewave, 0.5 V ±20%, 1 kHz ±20%.

Power Requirements — 90 to 250 V, 48 to 62 Hz without range switching, 50 watts max at 115 V and 60 Hz.

| Cabinet Dimensions | mm | in |
|--|-----|------|
| Height (with feet and handle) | 137 | 5.4 |
| Width (with handle) | 360 | 14.2 |
| Width (without handle) | 237 | 12.9 |
| Depth (with front cover) | 445 | 17.5 |
| Depth (without front cover) | 440 | 17.3 |
| Depth (with handle extended) | 511 | 20.1 |
| Weights (approx) | kg | lb |
| Net (with cover accessories, and pouch) | 7.6 | 16.8 |
| Net (without cover accessories, and pouch) | 6.1 | 13.5 |
| Shipping (domestic) | 8.2 | 18 |

INCLUDED ACCESSORIES

Two P6120 10X voltage probes (010-6120-00), two IC grabber probe accessories (013-0191-00).

ORDERING INFORMATION

2213 Dc to 60 MHz Dual Trace, Single Time Base Oscilloscope with Delayed Sweep \$1100

2215 Dc to 60 MHz Dual Trace, Delayed Alternate Time Base Oscilloscope \$1400

Power Cords — Standard: 110 Vac North American plug.

INTERNATIONAL POWER CORDS & PLUG OPTIONS

Option A1 Universal Euro 220 V/16A No Charge
Option A2 UK 240 V/13A No Charge
Option A3 Australian 240 V/10A No Charge
Option A4 North American 240 V/15A No Charge

OPTIONAL ACCESSORIES

Front Panel Cover (200-2520-00) \$5.00
Accessory Pouch (016-0677-00) \$42
Pouch and Cover (020-0672-00) \$47
Viewing Hood (016-0566-00) \$15
C-5C Option 04 Scope Camera \$500
Model 200C SCOPE-MOBILE® Cart \$265
Rack Adaptor Kit (016-0466-00) \$100

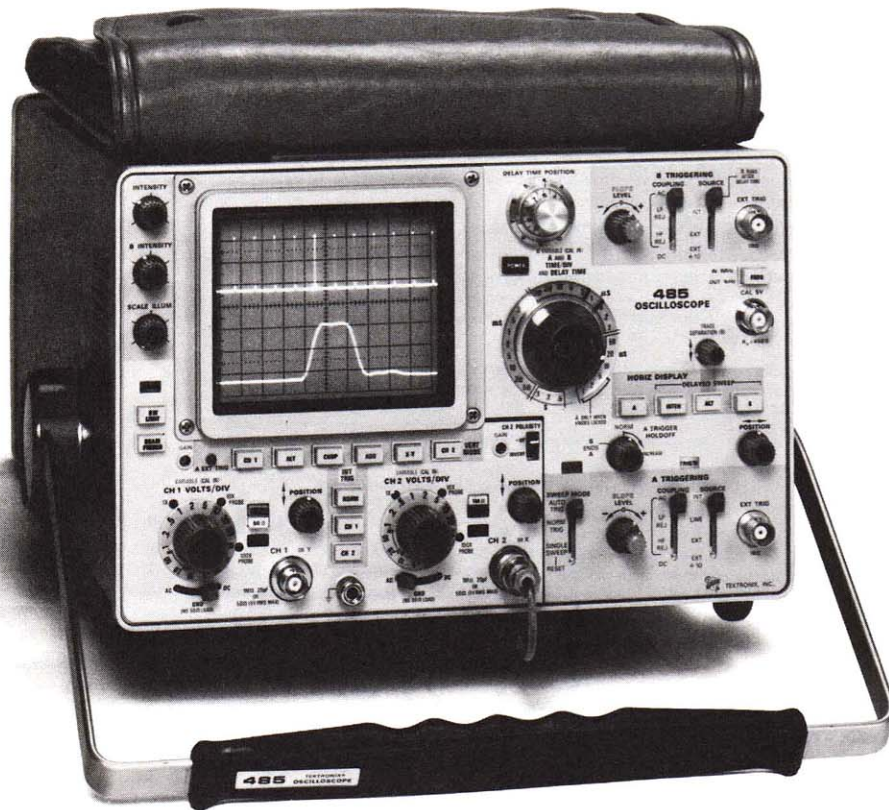

485

350 MHz at 5 mV/div

1 ns/div Sweep Rate

3.0 div/ns Writing Speed

1 MΩ and 50 Ω Input Impedances

Input Protection 50 Ω Internal

Automatic Deflection Factor Readout

Pushbutton Ext Trigger View

Battery Operation (Optional)

Weighs ≈9.5 kg

At just 21 pounds, the 1 ns/div dual-trace 485 is the only true portable 350 MHz oscilloscope on the market. This wide bandwidth is one reason why the 485 is highly compatible with today's increasing technology.

Many features contribute to the 485's extraordinary overall performance. Fast 3.0 div/ns writing speed is one, making it especially attractive for use in field research environments.

The 485 features a wide bandwidth at its full 5 mV/div vertical sensitivity (350 MHz at 50 Ω and 250 MHz at 1 MΩ). Selectable input impedance provides the capability to measure low and high impedance points with the same scope and without active probes.

Internal detection circuitry protects the 50 Ω input by automatically disconnecting when the signal exceeds approximately 5 V RMS.

You no longer have to mentally compensate for attenuating probes. Automatic vertical scale-factor readout is provided by three light-emitting diodes located around the edge of each input attenuator knob. A quick glance at the readout tells the operator the correct on-screen V/div when the recommended 10X or 100X probes are used.

And you always know exactly where you are in a pulse train when making a delayed sweep measurement. An alternate sweep mode allows the delayed sweep to appear alternately with the intensified main sweep. In this mode, you can view the intensified zone and the delayed display simultaneously.

The external trigger signal can be easily viewed on the 485. A front-panel pushbutton automatically routes the external signal used to trigger Time Base A to the vertical deflection amplifier. This feature can also be used to quickly make time comparisons between the signal of interest and the external trigger signal.

On the 485, focus is always correct in single-shot photography. An autofocus circuit eliminates the need to readjust the focus each time the intensity is changed.

When commercial power is not available, use the 1105 Battery Power Supply. It weighs only 19.5 pounds, and lets you take the high-performance 485 virtually anywhere.

Often chosen as a general-purpose scope for computer and electronic servicing environments because of its fast writing speed and wide bandwidth, the 485 can also be found in specialized and unusual applications. For example, to maintain a groundbased laser/radar acquisition system, the 485's alternate sweep switching mode proved an important factor.

VERTICAL DEFLECTION (2 Identical Channels)

Bandwidth* and Rise Time — (at all deflection factors from 50 Ω terminated source).

| | -15°C to +35°C | +35°C to +55°C |
|------|--------------------------|--------------------------|
| 50 Ω | Dc to 350 MHz, 1 ns | Dc to 300 MHz, 1.2 ns |
| 1 MΩ | Dc to 250 MHz, 1.4 ns | Dc to 200 MHz, 1.8 ns |

*Measured at — 3 dB. Bandwidth may be limited to ≈ 20 MHz by bandwidth limit switch.

Lower — 3 dB point, ac coupling 1X probe: 1 kHz or less for 50 Ω, and 10 Hz or less for 1 MΩ. 10X probe: 100 Hz or less for 50 Ω, and 1 Hz or less for 1 MΩ.

Deflection Factor — 5 mV/div to 5 V/div (1-2-5 sequence), accurate +2%. Uncalibrated, continuously variable between steps and to at least 12.5 V/div. Gain can be recalibrated at the front panel.

Display Modes — Ch 1, Ch 2 (normal and inverted), alternate, chopped (≈1 MHz rate), X-Y (Ch 1-Y and Ch 2-X), ADD (Ch 1 ± Ch 2).

Cmrr — Common-mode rejection ratio at least 20 dB at 50 MHz for common-mode signals of 6 div or less.

Automatic Scale Factor — Probe tip deflection factors for 1X, 10X, and 100X coded probes are automatically indicated by three readout lights at the edge of the knob skirts. All lights are off when the channel is not selected for display or when the trace identification control on the probe is depressed.

Selectable Input Impedance — 50 Ω and 1 MΩ impedances are available at a single BNC connector by pushbutton selection.

50 Ω ±0.5%; VSWR 1.15:1 or less from 20 mV/div to 5 V/div, 1.25:1 or less at 5 mV/div and 10 mV/div to 350 MHz.

Input R and C — 1 MΩ ±1% paralleled by ≈ 20 pF.

50 Ω Protection — Internal detection circuitry provides protection by automatically disconnecting excessive signals of up to 50 V. The "disconnected" condition is indicated, and has manual reset.

Max Input Voltage

| | | |
|------|---|--|
| 50 Ω | Protection disconnect occurs for voltages that exceed approx: 5 V RMS continuous 0.1 watt-second for instantaneous voltages of 5 V to 50 V. | |
| | Signals in excess of 150 V will damage the instrument. | |
| 1 MΩ | Dc coupled | 250 V (dc + peak ac), 500 V p-p to 1 kHz. |
| | Ac coupled | 500 V (dc + peak ac), 500 V p-p to 1 kHz. |

Selectable Input Coupling — Ac; dc; GND (provides zero reference, precharges coupling capacitor, disconnects 50 Ω load in 50 Ω mode).

Delay Line — Permits viewing leading edge of displayed waveform.

Probe Power — Connectors provide correct voltages for two optional P6201 FET Probes.

HORIZONTAL DEFLECTION

Time Base A and B — Calibrated sweep range; 1 ns/div to 0.5 s/div (1-2-5 sequence).

Variable Time Control — Time Base A provides continuously variable uncalibrated sweep rates between steps and to at least 1.25 s/div.

Time Base A and B Accuracy, center 8 div

| Sweep Rate | +15°C to +35°C | -15°C to +55°C |
|-------------------------|----------------|----------------|
| 1 ns/div to 20 ns/div | ±3% | ±5% |
| 50 ns/div to 0.1 s/div | ±2% | ±4% |
| 0.2 s/div and 0.5 s/div | ±3% | ±5% |

Horizontal Display Modes — A, intensified, alternate, and B (delayed sweep). A only is displayed for A sweep rates of 1, 2, and 5 ns/div. B ends A for increased intensity in the delayed mode.

Alternate Display Modes — Allows the B delayed sweep to appear alternately with the intensified A sweep. Trace separation control positions B (delayed sweep ≈4 div from the A sweep).

CALIBRATED SWEEP DELAY

Delay Time Range — 0 to 10X delay time/div setting of 10 ns/div to 0.5 s/div.

Differential Delay Time Measurement Accuracy

| | |
|-------------------------|--|
| Delay Time Setting | +15°C to +35°C |
| 10 ns/div and 20 ns/div | ± (1% of measurement + 0.2% of full scale) |
| 50 ns/div to 1 ms/div | ± (0.5% of measurement + 0.1% of full scale) |
| 2 ms/div to 0.5 s/div | ± (1% of measurement + 0.1% of full scale) |

Full scale is 10 times the delay time/div setting.

Jitter — 1 part or less in 20,000 of 10X the time/div setting.

TRIGGERING A and B

A Trigger Modes — Normal (sweep runs when triggered). Automatic (sweep free-runs in the absence of a triggering signal and for signals below 20 Hz). Single sweep (sweep runs one time on the first triggering event after the reset selector is pressed). Lights Indicate when sweep is triggered and when single sweep is ready.

A Trigger Holdoff — Adjustable control permits a stable presentation of repetitive complex waveforms. The control covers at least the time of one full sweep for faster than 0.2 s/div.

B Trigger Modes — B runs after delay time (starts automatically at the end of the delay time) and B triggerable after delay time (runs when triggered). The B (delayed) sweep runs once, in each of these modes, following the A sweep delay time.

Time Base A and B Trigger Sensitivity

| Coupling | | To 50 MHz | To 350 MHz |
|----------|----------|---|--------------------|
| Dc | Internal | 0.3 div deflection | 1.5 div deflection |
| | External | 20 mV | 100 mV |
| Ac | | Signals below 16 Hz are attenuated | |
| Ac Lf | Reject | Signals below 16 kHz are attenuated | |
| Ac Hf | Reject | Signals below 16 Hz and above 50 kHz are attenuated | |

Jitter — 0.1 ns or less at 350 MHz at 1 ns/div.

A Trigger View — A spring-loaded pushbutton overrides other vertical controls and displays the external signal used for A sweep triggering. This provides quick verification of the external signal and time comparison between a vertical signal and the external trigger signal. The deflection factor is ≈ 50 mV/div (0.5 V/div with external ÷ 10 source).

Level and Slope — Internal, permits selection of triggering at any point on the positive or negative slope of the displayed waveform. External, level is adjustable through at least ± 0.5 V for either polarity; ± 5 V for Ext ÷ 10.

A Sources — Internal, line, external, external ÷ 10

B Sources — B runs after delay time, internal, external, external ÷ 10.

External Inputs — R and C approx 1 MΩ paralleled by ≈ 20 pF. Max input voltage; 500 V (dc + peak ac), 500 V p-p to 1 kHz.

X-Y OPERATION

Full Sensitivity X-Y (Ch 1 Vert, Ch 2 Horiz) — 5 mV/div to 5 V/div, accurate ± 2%. Y-axis bandwidth identical to Channel 1. X-axis bandwidth is dc to at least 4 MHz (–3 dB). Phase difference between amplifiers is 3° or less to 4 MHz.

DISPLAY

CRT — 8 x 10 div display, each div is 0.8 cm. Horizontal and vertical centerlines further marked in 0.2 div increments. P31 Phosphor standard; P11 optional. 21 kV accelerating potential.

Photographic Writing Speed — At least 3 div/ns with standard P31 Phosphor and at least 6 div/ns with optional P11 Phosphor using the TEKTRONIX C-31R Camera and 3000 speed film.

Auto Focus — Automatically maintains beam focus for all intensity settings.

Graticule — Internal, nonparallax; variable edge lighting; markings for measurement of rise time.

Beam Finder — Compresses trace to within graticule area for ease in determining the location of an off-screen signal.

Z-Axis Input — Rise time ≈ 15 ns. Input R ≈ 50 Ω. +0.2 V (dc to 20 MHz) decreases intensity. + 2 V (dc to 2 MHz) blanks max intensity trace.

ENVIRONMENTAL CAPABILITIES

Ambient Temperature — Operating: –15°C to +55°C. Nonoperating: –35°C to +75°C. Filtered forced air ventilation is provided.

Altitude — Operating: to 15,000 ft; max allowable ambient temperature decreased by 1°C/1000 ft from 5000 to 15,000 ft. Nonoperating to 50,000 ft.

Vibration — Operating: 15 minutes along each of the three axes. 0.06 cm (0.025 in) p-p displacement (4 g's at 55 Hz) 10 to 55 to 10 Hz in 1 minute cycles.

Humidity — Operating and nonoperating: 5 cycles (120 hours) to 95% relative humidity referenced to MIL-E-16400F (par 4.5.9 through 4.5.9.5.1, class 4).

Shock — Operating and nonoperating: 30 g's, 1/2 sine, 11 ms duration, 2 shocks per axis in each direction for a total of 12 shocks.

OTHER CHARACTERISTICS

Two-Frequency, Fast-Rise Calibrator — Output resistance is 450 Ω with a rise time (positive slope) into 5 Ω of 1 ns or less. 1 kHz, duty cycle 49.8% to 50.2%, Amplitude is 5 V ± 0.5% into 1 MΩ and 0.5 V ± 1% into 50 Ω (± 0.5%). Optional BNC accessory current loop provides 50 mA ± 1%. Selectable repetition rates are 1 kHz and 1 MHz ± 0.25%. Specifications apply over +15°C to +35°C range.

A Sweep Output — Open circuit, ≈ 10 V positive-going sawtooth; into 50 Ω, ≈ 0.5 V.

A and B Gate Outputs — Open circuit, ≈ 4 V positive-going rectangular pulse; into 50 Ω ≈ 0.5 V.

Power Requirements — Recessed slide switch selects nominal operating line range. Line voltage range is 90 V to 136 V and 180 V to 272 V. 60 W max power consumption at 115 V. Line frequency 48 to 440 Hz.

PHYSICAL CHARACTERISTICS

| Dimensions | Cabinet | | Rackmount | |
|---------------------------|-----------|-----------|-----------|-----------|
| | cm | in | cm | in |
| Height | 16.8 | 6.6 | 17.7 | 7.0 |
| Width | 30.5 | 12.0 | 48.3 | 19.0 |
| Depth | | | 45.7 | 18.0 |
| (handle extended) | 52.3 | 20.6 | | |
| (handle not extended) | 47.0 | 18.5 | | |
| Weights (Approx) | kg | lb | kg | lb |
| Net (with accessories) | 10.9 | 24 | | |
| Net (without accessories) | 9.5 | 21 | 11.9 | 26.2 |
| Shipping | 15 | 33 | 24.5 | 54 |

INCLUDED ACCESSORIES

50 Ω, 18 inch BNC cable (012-0076-00), two BNC jack posts (012-0092-00), two 50 Ω terminators (011-0049-01) clear filter (386-0118-00), four 3 amp fuses (159-0015-00), accessory pouch (016-0535-00) or (016-0537-00). Rack models also include mounting hardware and slide out assemblies.

ORDERING INFORMATION

485 Oscilloscope \$6975
R485 Oscilloscope, 7 in Rack Model \$7145

INSTRUMENT OPTIONS

Option 04 Emc Modification for 485 Add \$110
Option 04 Emc Modification for R485 Add \$120
Option 78 P11 Phosphor Add \$35

INTERNATIONAL POWER CORDS AND PLUG OPTIONS

Option A1 Universal Euro 220 V/16A No Charge
Option A2 UK 224 V/13A No Charge
Option A3 Australian 240 V/10A No Charge
Option A4 North American 240 V/15A No Charge

For more information on instrument options, see your Tektronix Sales Engineer, Distributor, or Representative.

OPTIONAL ACCESSORIES

Probes —

| Input Terminal | Probe Type | Attenuation | Input Impedance | Bandwidth* with 485 |
|----------------|-------------------|----------------------------------|--|---------------------|
| 50 Ω Input | P6056 6 ft | 10X | 500 Ω 1 pF | 350 MHz |
| | P6057 6 ft | 100X | 5000 Ω 1 pF | 350 MHz |
| | P6201 FET 2 Meter | 1X 10X Head 100X Head | 100 kΩ 3 pF 1 MΩ 1.5 pF 1 MΩ 1.5 pF | 330 MHz |
| 50 Ω or 1 MΩ | P6202 2 Meter | 10X 100X Head (optional) | 10 MΩ 2 pF | 285 MHz |
| | P6106 2 Meter | 10X | 10 MΩ 13 pF | 250 MHz |
| 1 MΩ Input | P6063B 6 ft | 1X Switchable 10X | 1 MΩ 12 pF | 6 MHz |
| | | | 10 MΩ 14 pF | 200 MHz |
| Current Probe | Probe Type | Calibration | Insertion Impedance | Bandwidth* with 485 |
| | P6022 | 1 mA/mV 10 mA/mV (Selectable) | 0.03 Ω @ 1 MHz Increasing to 0.2 Ω @ 120 MHz | 130 MHz |

*Bandwidths are measured at the upper –3 dB, and apply only to the cable length shown. Generally, shorter cable lengths increase bandwidth, longer ones decrease bandwidth.

Current Loop Adapter — The adapter provides an accurate 50 mA squarewave calibrator when connected to the 485 voltage calibrator. The rise time is ≈ 25 ns.

Order 012-0341-00 \$45

50 Ω 5X Pad — Provides reverse termination for the calibrator.

Order 011-0060-02 \$35

Folding Viewing Hoods — Folds to 7/16 x 4 1/2 x 7 1/2 in (1.2 x 11.5 x 19.1 cm).

Order 016-0274-00 \$15

Folds to 9/16 x 6 3/4 x 13 3/4 in (1.4 x 17.2 x 34.9 cm).

Order 016-0082-00 \$15

SCOPE-MOBILE® Cart — Occupies <18 in aisle space, has storage area in base.

Order 200C \$265

1105 Battery Power Supply —

Order 1105 Battery Power Supply \$1240

Rack Adapter — 016-0558-00 \$275

RECOMMENDED CAMERAS

C-30BP General Purpose Camera — Includes 016-0306-01 mounting adapter.

Order C-30BP \$1245

C-31BP High Speed Camera — Includes 016-0306-00 mounting adapter.

Order C-31BP \$1430

For further information see Camera section.

Tektronix offers maintenance training classes on instruments in the 400 Series and multi-media training packages on Digital Counter and Meter Concepts and Basic Oscilloscope Maintenance Concepts. For further training information, contact your local Sales Office or request a copy of the Tektronix Customer Training Catalog on the return card.

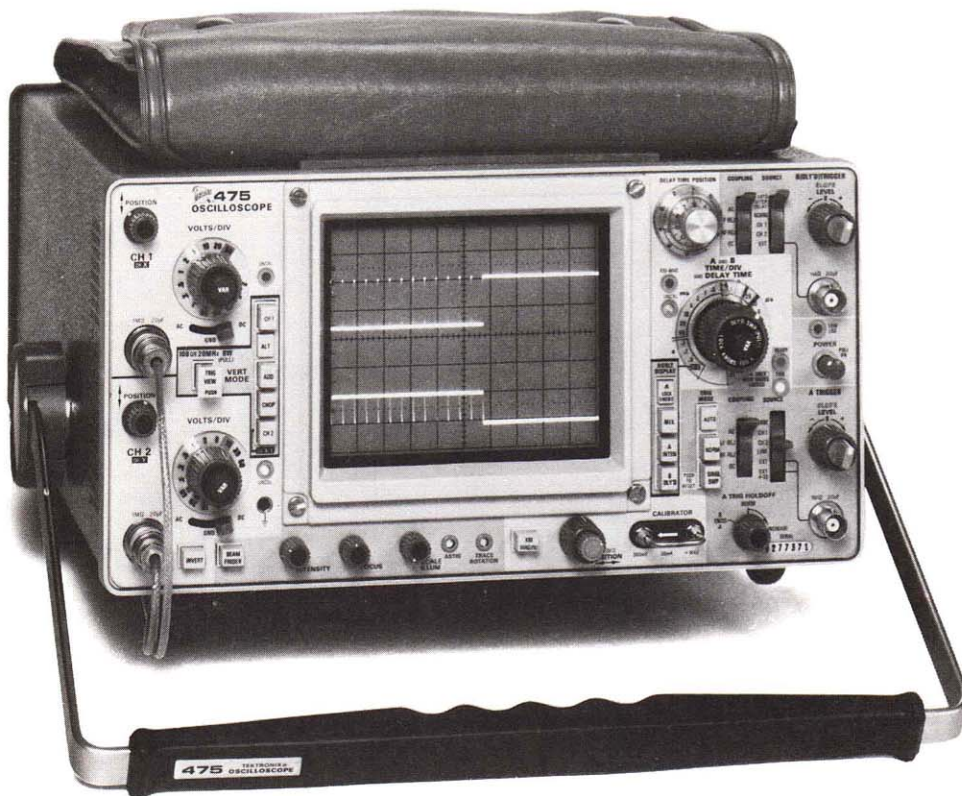

475/475A

1 ns/div Sweep Rate (475) (475A)
with X10 Sweep Magnifier

Trigger View

Versatile Trigger Selection

Battery Operation (Optional)

Weights \approx 10.3 kg (22.75 lb)

Both of these Tektronix Portables feature high performance and light weight for making complex measurements in the field.

1) The 475A provides a 250 MHz bandwidth at 5 mV/div. It features wider bandwidth than the 475, plus a more concise spot size and trace for particular applications.

2) With 200 MHz at 2 mV/div, the 475 features better sensitivity than the 475A. This bandwidth/sensitivity combination is useful in a wide variety of measurements.

Both the 475 and 475A offer 2% (1 ns/div) or 1% (10 ns/div) timing accuracy, which can be critical in servicing computers.

Both oscilloscopes are light, compact, and rugged for portability and durability, yet each contains a large, bright 8 x 10 cm CRT. Operation has been simplified by single-function pushbuttons, control knob design, layout, and color-coordinated front panels.

Determining deflection factors used to be error-prone and costly. Now, it's a problem of the past...readout lights behind knob skirts automatically indicate the proper probe tip deflection factors for recommended 1X and 10X probes.

Measuring with respect to ground is important in many applications. This is controlled at the probe when dc-coupled by simply pressing the small ground reference button on recommended probes.

You can choose from the 1105 or 1106 Battery Packs. Both are small and light weight, and provide a ready solution for making accurate measurements in difficult environments such as conducted emc, ground loops, power line fluctuations or where line power is nonexistent.

Applications for these instruments are widespread. The 475 performs tests and measurements aboard flight test aircraft, in both stationary and portable modes.

CHARACTERISTICS

All characteristics are common to the 475 and 475A except where indicated.

VERTICAL DEFLECTION (2 Identical Channels)

Bandwidth* and Rise Time — (At all deflection factors from 50 Ω terminated source).

| | -15°C to +40°C | +40°C to +55°C |
|------|-----------------------|-----------------|
| 475 | Dc to 200 MHz, 1.8 ns | 175 MHz, 2.0 ns |
| 475A | Dc to 250 MHz, 1.4 ns | 250 MHz, 1.4 ns |

*Measured at -3 dB, bandwidth may be limited to \approx 20 MHz by bandwidth limit switch.

Lower -3 dB point, ac coupling 1X probe: 10 Hz or less. 10X probe: 1 Hz or less.

Deflection Factor at BW —

475 — 2 mV/div to 5 V/div

475A — 5 mV/div to 10 V/div

1-2-5 sequence, accurate \pm 3%. Uncalibrated, continuously variable between steps and to at least 12.5 V/div (475) to at least 25 V/div (475A). In cascade mode sensitivity is \approx 400 μ V/div (475); and \approx 2.5 mV/div (475A). Cascaded bandwidth is at least 50 MHz (475/475A) when signal out is terminated in 50 Ω .

Display Modes — Ch 1; Ch 2 (normal and inverted), alternate, chopped (\approx 1 MHz rate), added; X-Y (Ch 1-X, Ch 2-Y).

Cmrr — Common-mode rejection ratio at least 20 dB at 1 kHz for common-mode signals of 8 div or less.

Automatic Scale Factor — Probe tip deflection factors for 1X or 10X coded probes are automatically indicated by two read-out lights behind the knob skirts. All lights are off when the channel is not displayed. Ground reference display selectable at probe (when dc coupled).

Input R and C — 1 M Ω \pm 2%, paralleled by \approx 20 pF.

Max Input Voltage

| | |
|------------|---------------------------------|
| Dc coupled | 250 V (dc + peak ac) |
| | 500 V (p-p ac at 1 kHz or less) |
| Ac coupled | 500 V (dc + peak ac) |
| | 500 V (p-p ac at 1 kHz or less) |

Delay Line — Permits viewing leading edge of displayed waveform.

Probe Power — Connectors provide correct voltages for two optional P6201 FET Probes.

HORIZONTAL DEFLECTION

Time Base A and B — 0.01 μ s/div to 0.5 s/div (1-2-5 sequence). X10 mag extends max sweep rate to 1 ns/div.

Variable Time Control — Time Base provides continuously variable uncalibrated sweep rates between steps and to at least 1.25 s/div. Warning light indicates uncalibrated setting.

Time Base A and B Accuracy, full 10 cm

| | +20°C to +30°C | -15°C to +55°C |
|-------------|----------------|----------------|
| Unmagnified | \pm 1% | \pm 2% |
| Magnified | \pm 2% | \pm 3% |

Horizontal Display Modes — A, mixed sweep, A intensified, B delayed, B ends A for increased intensity in the delayed mode.

Calibrated Mixed Sweep — Displays A sweep for period determined by delay-time position control, then displays B sweep for remainder of horizontal sweep.

CALIBRATED SWEEP DELAY

Delay Time Range — 0 to X10 delay time/div settings of 50 ns to 0.5 s (minimum delay time is 50 ns).

Differential Time Measurement Accuracy —

| Delay Time Setting | +15°C to +35°C |
|---------------------------------------|--------------------------------|
| over one or more major dial divisions | \pm 1% |
| less than one major dial division | \pm 0.01 major dial division |

Jitter — One part or less in 50,000 (0.002%) of X10 the A sweep time/div setting. One part in 20,000 when operating from 50 Hz line.

TRIGGERING A AND B

A Trigger Modes — Normal (sweep runs when triggered). Automatic (sweep free-runs in the absence of a triggering signal and for signals below 30 Hz). Single Sweep (sweep runs one time on the first triggering event after the reset selector is pressed). Lights indicate when sweep is triggered and when single sweep is ready.

A Trigger Holdoff — Adjustable control permits a stable presentation of repetitive complex waveforms.

B Trigger Modes — B runs after delay time (starts automatically at the end of the delay time) and B triggerable after delay time (runs when triggered). The B (delayed) sweep runs once, in each of these modes, following the A sweep delay time.

Time Base A and B Trigger Sensitivity and Coupling

| Coupling | 475 | | 475A | | |
|--------------|--|--------------------|--------------------|--------------------|--------------------|
| | To 40 MHz | At 200 MHz | to 40 MHz | At 250 MHz | |
| Dc | Internal | 0.3 div deflection | 1.5 div deflection | 0.3 div deflection | 2.0 div deflection |
| | External | 50 mV | 250 mV | 50 mV | 250 mV |
| | External $\div 10$ | 500 mV | 2.5 V | 500 mV | 2.5 V |
| Ac | Requirements increase below 60 Hz | | | | |
| Ac Lf Reject | Requirements increase below 50 kHz | | | | |
| Ac Hf Reject | Requirements increase below 60 Hz and above 50 kHz | | | | |

475 Jitter — 0.2 ns or less at 200 MHz and 1 ns/div.

475A Jitter — 0.2 ns or less at 250 MHz and 1 ns/div.

A Trigger View — A spring-loaded pushbutton overrides other vertical controls and displays the external signal used for A sweep triggering. This provides quick verification of the signal and time comparison between a vertical signal and the trigger signal. The deflection factor is ≈ 50 mV/div (0.5 V/div with external $\div 10$ source).

Level and Slope — Internal, permits selection of triggering at any point on the positive or negative slope of the displayed waveform. Level adjustment through at least ± 2 V in external, through at least ± 20 V in external $\div 10$.

A Sources — Norm, Ch 1, Ch 2, line, external, and external $\div 10$.

B Sources — Starts after delay, norm, Ch 1, Ch 2, and external.

External Inputs — R and C ≈ 1 M Ω paralleled by ≈ 20 pF. 250 V (dc + peak ac) max input.

X-Y OPERATION

Full-Sensitivity X-Y (Ch 1 Horiz, Ch 2 Vert) — 2 mV/div to 5 V/div (475), 5 mV to 10 V/div (475A) accurate $\pm 3\%$. Bandwidth is dc to at least 3 MHz. Phase difference between amplifiers is 1° or less from dc to 1 MHz.

DISPLAY

CRT — 8 x 10 cm display. Horizontal and vertical centerlines further marked in 0.2 cm increments. P31 Phosphor standard; P11 optional. 18 kV accelerating potential.

Graticule — Internal, nonparallax; variable edge lighting; markings for measurement of rise time.

Beam Finder — Compresses trace to within graticule area for ease in determining the location of an off-screen signal. A pre-set intensity level provides a constant brightness.

Z-Axis Input — Dc coupled, positive-going signal decreases intensity; 5 V p-p signal causes noticeable modulation at normal intensity; dc to 50 MHz.

ENVIRONMENTAL CAPABILITIES

Ambient Temperature — Operating: -15°C to $+55^\circ\text{C}$. Nonoperating: -55°C to $+75^\circ\text{C}$. Filtered forced air ventilation is provided.

Altitude — Operating: to 15,000 ft; max allowable ambient temperature decreased by $1^\circ\text{C}/1000$ ft from 5000 to 15,000 ft. Nonoperating to 50,000 ft.

Vibration — Operating: 15 minutes along each of the three axes, 0.06 cm (0.025 in) p-p displacement (4 g's at 55 Hz) 10 to 55 to 10 Hz in 1 minute cycles.

Humidity — Operating and nonoperating: 5 cycles (120 hours) to 95% relative humidity referenced to MIL-E-16400F (par 4.5.9 through 4.5.9.5.1, class 4).

Shock — Operating and nonoperating: 30 g's 1/2 sine, 11 ms duration, 2 shocks per axis in each direction for a total of 12 shocks.

OTHER CHARACTERISTICS

Amplitude Calibrator

| | | |
|----------------|--------------|----------------------|
| Output Voltage | 0.3 V | 1% 0°C to +40°C |
| Output Current | 30 mA | 2% +20°C to +30°C |
| Frequency | Approx 1 kHz | |

Vertical Signal Output — Ch 2 vertical signal is dc to at least 50 MHz (-3 dB), and ≈ 10 mV/div terminated into 50 Ω , and ≈ 20 mV/div terminated in 1 M Ω .

Gate Outputs — Positive gates from both time bases (≈ 5 V).

Power Requirements — Quick-change line voltage selector provides six ranges: 110 V, 115 V, 120 V, 220 V, 230 V, and 240 V, each $\pm 10\%$. 48 to 440 Hz, or 100 watts max at 115 V and 60 Hz. Operation from 12 or 24 V dc is available with Option 07.

PHYSICAL CHARACTERISTICS

| Dimensions | Cabinet | | Rackmount | |
|--|-----------|-----------|-----------|-----------|
| | cm | in | cm | in |
| Height (w/o pouch) | 15.7 | 6.2 | 17.7 | 7.0 |
| Width (with handle) | 32.8 | 13.1 | 48.3 | 19.0 |
| Depth (with panel cover) | 46.0 | 18.1 | 45.7 | 18.0 |
| Depth (handle extended) | 51.6 | 20.3 | | |
| Weights (approx) | kg | lb | kg | lb |
| Net (without panel cover) | 10.3 | 22.8 | 13.3 | 29.4 |
| Net (with panel cover and accessories) | 11.5 | 25.3 | | |
| Shipping | 16.7 | 37.0 | 26.3 | 58.0 |

INCLUDED ACCESSORIES

Two P6106 10X probes (010-6106-03), blue accessory pouch (016-0594-00), clear pouch (016-0537-00), blue CRT light filter (337-1674-00), clear CRT light filter (337-1674-01), BNC male to ground wire (134-0016-01), two 1 1/2-amp fuses (159-0016-00), one 3/4-amp fuse (159-0042-00). Rack models also include mounting hardware and slide out assemblies, do not include accessory pouches.

ORDERING INFORMATION

| | |
|--|--------|
| 475 Oscilloscope | \$3960 |
| 475A Oscilloscope | \$4410 |
| R475 Rackmount Oscilloscope | \$4130 |
| R475A Rackmount Oscilloscope | \$4580 |
| 475 DM 44 DM 44 info on page 233 | \$4465 |
| 475A DM 44 (order 475A 44) | \$4915 |

INSTRUMENT OPTIONS

| | |
|---|-----------|
| Option 01 Delete Temperature | |
| Probe on DM 44 | Sub \$80 |
| Option 04 Emc Modification | Add \$140 |
| Option 07 Ext Dc Operation | Add \$220 |
| Option 07 cannot be ordered with DM 44. | |
| Option 78 P11 Phosphor | Add \$35 |

Modification kits for field conversion of existing 475s or 475As to Option 04, Option 07, or DM 44 equipped scopes are available. These are typically more expensive than when the option is ordered with the instrument. Contact your Tektronix Sales Engineer, Distributor, or Representative for information.

INTERNATIONAL POWER CORDS AND PLUG OPTIONS

| | |
|--|-----------|
| Option A1 Universal Euro 220 V/16A | No Charge |
| Option A2 UK 240 V/13A | No Charge |
| Option A3 Australian 240 V/10A | No Charge |
| Option A4 North American 240 V/15A | No Charge |

Tektronix offers maintenance training classes on instruments in the 400 Series and multi-media training packages on Digital Counter and Meter Concepts and Basic Oscilloscope Maintenance Concepts. For further training information, contact your local Sales Office or request a copy of the Tektronix Customer Training Catalog on the return card.

OPTIONAL ACCESSORIES

Probes

| Probe Type | Attenuation | Input Impedance | Bandwidth* with | |
|----------------------------------|-------------------------------------|---|-----------------|---------|
| | | | 475 | 475A |
| P6063B 6 ft | 1X | 1 M Ω 105 pF | 6 MHz | 6 MHz |
| | Switchable 10X | 10 M Ω 14 pF | 145 MHz | 160 MHz |
| P6202 FET Probe 2 Meter | 10X | 10 M Ω 2 pF | 185 MHz | 220 MHz |
| | 100X Head | 10 M Ω 2 pF | 185 MHz | 220 MHz |
| | Ac Head | 10 M Ω 4 pF | 185 MHz | 220 MHz |
| Current Probe | Calibration | Insertion Impedance | Bandwidth with | |
| P6022 5 ft | 1 mA/mV 10 mA/mV (Selectable) | 0.03 Ω @ 1 MHz In- creasing to 0.2 Ω @ 120 MHz | 125 MHz | 160 MHz |
| | | | | |

*Bandwidths are measured at the upper -3 dB and apply only to the cable length shown. Generally shorter cable lengths increase bandwidth, longer ones decrease bandwidth.

Folding Polarized Viewing Hood

Order 016-0180-00 \$40

Collapsible Viewing Hood — Binocular

Order 016-0566-00 \$15

Protective Cover — Waterproof, blue vinyl

Order 016-0554-00 \$17

Mesh Filter — Improves contrast and emc filtering

Order 378-0726-01 \$45

SCOPE-MOBILE* Cart — Occupies <18 in aisle space, has storage area in base.

Order 200C \$265

1105 Battery Power Supply \$1240

Rack Adapter (not for use with DM 44)

Order 016-0556-00 \$275

RECOMMENDED CAMERA

C-30BP Option 01 General Purpose Compact Camera

Includes 016-0301-01 mounting adapter/corrector lens.

Order C-30BP Option 01 \$1285

For further information see Camera section.

Battery Packs



1106 BATTERY PACK

The 1106 is a convenient, snap-on battery power supply for TEKTRONIX 455, 464, 465B, 466, 475 or 475A Oscilloscopes when the scope is ordered with Option 07.

Output Power — 22 to 26 V dc; 100 watt-hours from full charge.

Charging Power Source — 90 to 132 V ac, 50 to 400 Hz; or 180 to 264 V ac, 50 to 400 Hz.

Charging Time — 14 to 16 hours.

Weight — 7.2 kg (16 lb).

Order 1106 Battery Pack \$905

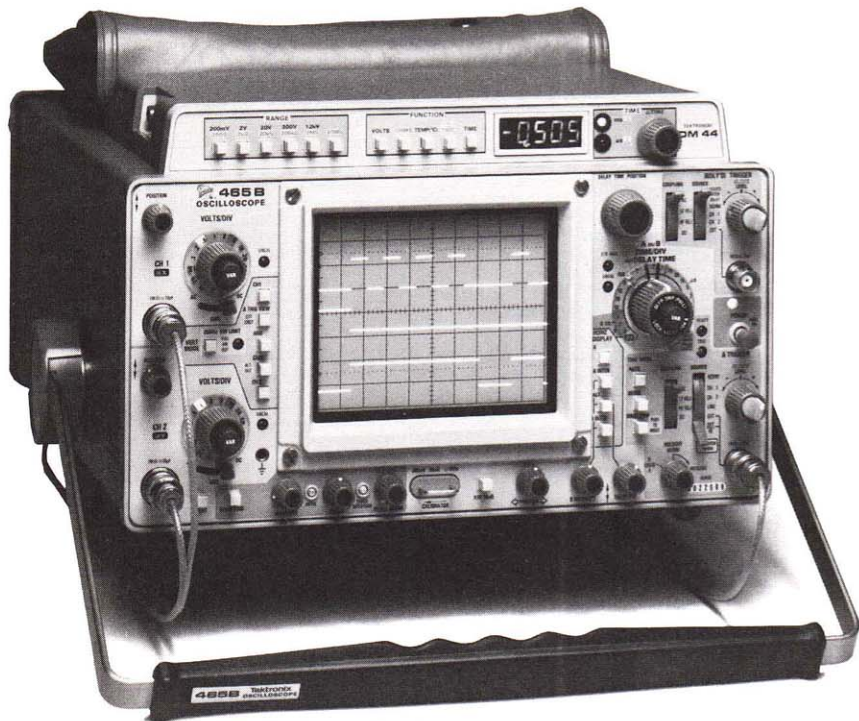

465B44 Oscilloscope/DMM Shown Above Includes DM44 Digital Multimeter.

465B/DM44

100 MHz at 5 mV/div

2 ns/div Sweep Rate with X10 Sweep Mag

Trigger View

Versatile Trigger Selection

Alternate Sweep

The 465B offers upgraded performance to match advancements in technology, while providing improved trace quality, easier maintenance, and greater operator flexibility.

Improved trace selection versatility allows you to choose channel 1 and/or channel 2, sum or difference, and A trigger view in any combination.

In addition, the 465B has all the features of the original 465: 5 mV/div vertical trace, delayed sweep, the differential time/DMM option, and a sharp, bright 8 x 10 cm CRT.

VERTICAL DEFLECTION (2 Identical channels)

Bandwidth* and Rise Time — (at all deflection factors from 50 Ω terminated source)

| | |
|-----------------------|----------------|
| -15°C to +40°C | +40°C to +55°C |
| Dc to 100 MHz, 3.5 ns | 85 MHz, 4.1 ns |

*Measured at -3 dB. Bandwidth may be limited to \approx 20 MHz by bandwidth limit switch.

Cascaded bandwidth is at least 50 MHz when signal out is terminated in 50 Ω .

Lower -3 dB point, ac coupling 1X probe: 10 Hz or less. 10X probe: 1 Hz or less.

Deflection Factor at BW — 5 mV/div to 5 V/div. 1-2-5 sequence, accurate \pm 3%. Uncalibrated, continuously variable between steps and to at least 12.5 V/div. LED warning light indicates uncalibrated setting. In cascade mode sensitivity is \approx 1 mV/div.

Display Modes — Ch 1; Ch 2 ADD (normal and inverted), alternate, chopped— \approx 500 kHz rate, in any combination electronically switched.

CMrr — Common-mode rejection ratio at least 20 dB at 20 MHz for common-mode signals of 6 div or less.

Automatic Scale Factor — Probe tip deflection factors for 1X or 10X coded probes are indicated by two readout lights behind knob skirts. LEDs are off when channel not displayed. Ground reference display selectable at probe (when dc coupled).

Input R and C — 1 M Ω \pm 2%, paralleled by \approx 20 pF.

Max Input Voltage —

| | |
|------------|---------------------------------|
| Dc coupled | 250 V (dc + peak ac) |
| | 500 V (p-p ac at 1 kHz or less) |
| Ac coupled | 250 V (dc + peak ac) |
| | 500 V (p-p at 1 kHz or less) |

Delay Line — Permits viewing leading edge of displayed waveform.

HORIZONTAL DEFLECTION

Time Base A — 0.02 μ s/div to 0.5 s/div (1-2-5 sequence). X10 mag extends max sweep rate to 2 ns/div. LED indicates X10 mag.

Time Base B — 0.02 μ s/div to 50 ms/div (1-2-5 sequence). X10 mag extends max sweep rate to 2 ns/div. LED indicates X10 mag.

Variable Time Control — Time Base A provides continuously variable uncalibrated sweep rates between steps and to at least 1.25 s/div. LED warning light indicates uncalibrated setting.

Time Base A and B Accuracy, full 10 cm

| | | |
|-------------|----------------|----------------|
| | +20°C to +30°C | -15°C to +55°C |
| Unmagnified | \pm 2% | \pm 3% |
| Magnified | \pm 3% | \pm 4% |

Horizontal Display Modes — A, A intensified, alternate (A intensified and B delayed), B delayed, B ends A for increased intensity in the delayed mode. Electronic switching between intensified and delayed sweep. A sweep and B sweep may be viewed simultaneously.

CALIBRATED SWEEP DELAY

Delay Time Range — 0.2 to X10 delay time/div settings of 200 ns to 0.5 s.

Differential Time Measurement Accuracy —

| | |
|---------------------------------------|---------------------------------|
| Delay Time Setting | +15°C to +35°C |
| over one or more major dial divisions | \pm 1% |
| less than one major dial division | \pm 0.01 major dial divisions |

Jitter — 1 part or less in 50,000 (0.002%) of 10X the A sweep time/div setting. 1 part in 20,000 when operating from 50 Hz line.

TRIGGERING A AND B

A Trigger Modes — Normal (sweep runs when triggered), automatic (sweep runs in the absence of a triggering signal and for signals below 30 Hz), Single Sweep (sweep runs one time on the first triggering event after the reset selector is pressed). LED lights indicate when sweep is triggered and when single sweep is ready.

A Trigger Holdoff — Adjustable control permits a stable presentation of repetitive complex waveforms.

B Trigger Modes — B runs after delay time (starts automatically at the end of the delay time) and B triggerable after delay time (runs when triggered). The B (delayed) sweep runs once, in each of these modes, following the A sweep delay time.

Time Base A and B Trigger Sensitivity and Coupling —

| COUPLING | to 25 MHz | At 100 MHz |
|--------------------|--|--------------------|
| Dc | 0.3 div deflection | 1.5 div deflection |
| External | 50 mV | 150 mV |
| External \div 10 | 500 mV | 1.5 V |
| Ac | Requirements increase below 60 Hz | |
| Ac Lf Reject | Requirements increase below 50 kHz | |
| Ac Hf Reject | Requirements increase below 60 Hz and above 50 kHz | |

Jitter — 0.5 ns or less at 100 MHz and 2 ns/div.

Zero Delay A Trigger View — Electronically switched trigger view displays the external signal used for A sweep triggering. This provides quick verification of the signal and time comparison between a vertical signal and the trigger signal which can be displayed simultaneously. The deflection factor is \approx 100 mV/div (1 V/div with external \div 10).

Level and Slope — Internal, permits selection of triggering at any point on the positive or negative slope of the displayed waveform. Level adjustment through at least \pm 2 V in external, through at least \pm 20 V in external \div 10.

A Sources — Norm, Ch 1, Ch 2, line, external, and external \div 10.

B Sources — Starts after delay, norm, Ch 1, Ch 2, and external.

External Inputs — R and C \approx 1 M Ω paralleled by \approx 20 pF. 250 V (dc + peak ac) max input.

X-Y OPERATION

Full-sensitivity X-Y (Ch 1 Horiz, Ch 2 Vert) — 5 mV/div to 5 V/div, accurate \pm 4%. Bandwidth is dc to at least 4 MHz. Phase difference between amplifiers is 3° or less from dc to 50 kHz.

DISPLAY

CRT — 8 x 10 cm display. Horizontal and vertical centerlines further marked in 0.2 cm increments. P31 phosphor standard; P11 optional. 18 kV accelerating potential.

Graticule — Internal, nonparallax; variable edge lighting; markings for measurement of rise time.

Beam Finder — Compresses trace to within graticule area for ease in locating an offscreen signal. A preset intensity level provides a constant brightness.

Z-Axis Input — Dc coupled, positive-going signal decreases intensity; 5 V p-p signal causes noticeable modulation at normal intensity; dc to 50 MHz.

ENVIRONMENTAL CAPABILITIES

Ambient Temperature — Operating: -15°C to +55°C. Non-operating: -62°C to +85°C. Filtered forced air ventilation is provided.

Altitude — Operating: to 15,000 ft; max allowable ambient temperature decreased by 1°C/1000 ft from 5000 to 15,000 ft. Nonoperating to 50,000 ft.

Vibration — Operating: 15 minutes along each of the three axes, 0.06 cm (0.025 in) p-p displacement (4 g's at 55 Hz) 10-55 - 10 Hz in 1 minute cycles.

Humidity — Operating and nonoperating: 5 cycles (120 hours) to 95%-97% relative humidity as specified in MIL-T-28800B (par 3.9.2.2).

Shock — Operating and nonoperating: 30 g's 1/2 sine, 11 ms duration, 3 shocks per axis in each direction for a total of 18 shocks.

OTHER CHARACTERISTICS

Amplitude Calibrator —

| | | |
|----------------|-----------------|----------------------|
| Output Voltage | 0.3 V | 1% 0°C to +40°C |
| Output Current | 30 mA | 2% +20°C to +30°C |
| Frequency | Approx 1 kHz | |

Vertical Signal Output — Ch 1 vertical signal is dc to at least 50 MHz (–3 dB), and ≈25 mV/div terminated into 50 Ω, and ≈50 mV/div terminated into 1 MΩ.

Gate Outputs — Positive gates from both time bases (≈5 V).

Power Requirements — Quick-change line voltage selector provides six ranges: 110 V, 115 V, 120 V, 220 V, 230 V, and 240 V, each ±10%. 48 to 440 Hz, 85 watts max at 115 V and 60 Hz. Operation from 12 or 24 V dc is available with Opt 07.

PHYSICAL CHARACTERISTICS

| Dimensions | Cabinet | | Rackmount | |
|--|---------|------|-----------|------|
| | cm | in | cm | in |
| Height | 15.7 | 6.2 | 17.7 | 7.0 |
| Width (with handle) | 32.8 | 13.1 | 48.3 | 19.0 |
| Depth (with panel cover) | 46.0 | 18.1 | 45.7 | 18.0 |
| Depth (handle extended) | 51.6 | 20.3 | | |
| Weights (approx) | kg | lb | kg | lb |
| Net (without panel cover) | 10.3 | 22.8 | 13.3 | 29.4 |
| Net (with panel cover and accessories) | 11.5 | 25.3 | | |
| Shipping | 16.7 | 37.0 | 26.3 | 58.0 |

INCLUDED ACCESSORIES

Two P6105 10X probes (010-6105-03), blue accessory pouch (016-0535-02), clear pouch (016-0537-00), blue CRT light filter (337-1674-00), clear CRT light filter (337-1674-01), ground wire (134-0016-01), two 1 1/2-amp fuses (159-0016-00), one 3/4-amp fuse (159-0042-00). Rack models also include mounting hardware and slide out assemblies, but not pouches.

ORDERING INFORMATION

- 465B Oscilloscope** \$2995
- R465B Rackmount Oscilloscope** \$3165
- 465B44 Oscilloscope/DMM** \$3500

INSTRUMENT OPTIONS

- Option 01, Delete Temperature Probe on 465B44** Sub \$80
- Option 04, Emc Modification** Add \$140
- Option 05, TV Sync Separator** (Provides triggering on TV field and TV line) Add \$260
- Option 07, Ext Dc Operation** Add \$220
- Option 07 cannot be ordered with 465B44.**
- Option 78, P11 Phosphor** \$35

Modification kits for field conversion of existing 465Bs, to Option 04, Option 07, or 465B44 scopes are available. These are typically more expensive than when the option is ordered with the instrument. Contact your Tektronix Sales Engineer, Distributor, or Representative for information.

INTERNATIONAL POWER CORDS AND PLUG OPTIONS

- Option A1 Universal Euro 220 V/16A** No Charge
- Option A2 UK 240 V/13A** No Charge
- Option A3 Australian 240 V/10A** No Charge
- Option A4 North American 240 V/15A** No Charge

OPTIONAL ACCESSORIES

| Probes — Probe Type | Attenuation | Input Impedance | Bandwidth* |
|----------------------------------|-------------------------------------|--|--------------------|
| P6063B 6 ft | 1X | 1 MΩ 105 pF | 6 MHz |
| | Switchable 10X | 10 MΩ 14 pF | 90 MHz |
| P6202 FET Probe 2 Meter | 10X | 10 MΩ 2 pF | 100 MHz |
| | 100X Head Ac Head | 10 MΩ 2 pF 10 MΩ 4 pF | 100 MHz 100 MHz |
| Current Probe | Calibration | Insertion Impedance | |
| P6022 5 ft | 1 mA/mV 10 mA/mV (Selectable) | 0.03 Ω @ 1 MHz Increasing to 0.2 Ω @ 120 MHz | 85 MHz |

*Bandwidths are measured at the upper –3 dB and apply only to the cable length shown. generally, shorter cable lengths increase bandwidth.

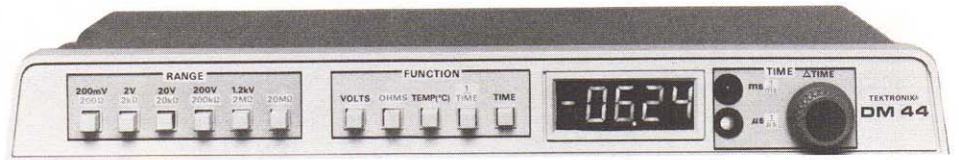

DM 44 DIFFERENTIAL-TIME/DMM OPTION

1% timing measurements were never this easy! With the DM 44 Option, available on five TEKTRONIX 400 Series Portables, time intervals can be read directly from the 3 1/2 digit LED Screen. Simply use the Delay Time control and the Δ time dial to position intensified spots at the beginning and end of the interval you wish to measure. Next, switch to delayed sweep and use the Δ time dial to superimpose the end of the interval on the beginning. Then read its differential time or frequency from the 3 1/2 digit LED panel. It's that simple. Time intervals are accurate to 1% and the frequency of periodic waveforms can be read out with 2% accuracy by simply pushing the 1/Time button.

Compare the DM 44 sequence with the measurement technique you may now be using. Calculating the interval from the CRT may take 10 times as long.

Voltage, resistance, and temperature measurements are also much easier with a DM 44-equipped 400 Series Oscilloscope. The DM 44 measures dc voltage with 0.1% accuracy, resistance with 0.3% accuracy, and temperature from –55°C to 150°C. Previously, you would have needed a separate DMM and digital thermometer in addition to your oscilloscope. Now, these features are combined in one small, inexpensive, integral package.

The DM 44 is available as a factory installed option on the 464, 465B, 466, 475 and 475A Portables. It adds Delta Delayed Sweep and independent DMM capabilities to these 400 Series Scopes. First, consider your bandwidth, sensitivity, storage, and price requirements. Then specify the DM 44 Option for simple and accurate digital measurements.

DM 44 CHARACTERISTICS

Timing Measurements

Differential Time Delay Accuracy —

| +15°C to +35°C | –15°C to +55°C | used with 475 and 475A |
|---|---------------------------------|---------------------------------|
| used with 464, 465B, 466, 475, and 475A | used with 464, 465B, and 466 | used with 475 and 475A |
| within 1% of reading ±1 count | within 2.5% of reading ±1 count | within 1.5% of reading ±1 count |

1/Time Accuracy —

| +15°C to +35°C | –15°C to +55°C | used with 475 and 475A |
|---|---------------------------------|-------------------------------|
| used with 464, 465B, 466, 475, and 475A | used with 464, 465B, and 466 | used with 475 and 475A |
| within 2% of reading ±1 count | within 3.5% of reading ±1 count | within 3% of reading ±1 count |

DC Voltage

Ranges — 0-200 mV, 0-2 V, 0-20 V, 0-200 V, 0-1.2 kV.
Resolution — 100 μV.
Accuracy — Within 0.1% of reading ±1 count.
Input Resistance — 10 MΩ for all ranges. Removal of an internal strap increases resistance to ≈1000 MΩ on 200 mV and 2V ranges.
Normal-Mode Rejection Ratio — At least 60 dB at 50 Hz and 60 Hz.
Common-Mode Rejection Ratio — At least 100 dB at dc, 80 dB at 50 Hz and 60 Hz.
Recycle Rate — ≈3.3 measurements/s.
Response Time — Within 0.5 s.

Maximum Safe Input Voltage — ±1200 V dc + peak ac between + and common inputs or between + and chassis. ±500 V (dc + peak ac) common floating voltage between common and chassis.

Resistance

Ranges — 0-200 Ω, 0-2 kΩ, 0-20 kΩ, 0-200 kΩ, 0-2 MΩ and 0-20 MΩ.
Resolution — 0.1 Ω.
Accuracy —

| Range | Accuracy |
|---------------------------|--|
| 200 Ω | within 0.25% ±1 count + probe resistance |
| 2 kΩ, 20 kΩ, 200 kΩ, 2 MΩ | within 0.25% ±1 count |
| 20 MΩ | within 0.3% ±1 count |

Recycle Rate — ≈3.3 measurements/s.

Response Time —

| | |
|-----------------------------|------------|
| 200 Ω through 200 kΩ ranges | within 1 s |
| 2 MΩ ranges 20 MΩ ranges | within 5 s |

Maximum Safe Input Voltage — 120 V RMS between + and common inputs.

Temperature Using P6430 Probe

Range — –55°C to +150°C.

Accuracy —

| DM 44 Temp | P6430 Tip Temp | Accuracy probe calibrated to DM 44 |
|----------------|------------------|------------------------------------|
| +15°C to +35°C | –55°C to +150°C | ±2°C |
| –15°C to +55°C | –55°C to +125°C | ±3°C |
| | +125°C to +150°C | ±4°C |

INCLUDED ACCESSORIES

One pair, Test Leads (003-0120-00), one P6430 Temperature Probe (010-6430-00).

ORDERING INFORMATION

- 465B DM 44 (Order 465B 44)** \$3500
- 475 DM 44 Oscilloscope/DMM** \$4465
- 475A DM 44 (Order 475A 44)** \$4915
- 466 DM 44 Oscilloscope/DMM** \$6890
- 464 DM 44 Oscilloscope/DMM** \$5670

INSTRUMENT OPTIONS

Option 01 Delete Temperature Probe Sub \$80
 Modification kits for field conversion of existing 464s, 465s, 466s, 475s, and 475As to DM 44-equipped scopes are available. These are typically more expensive than when the option is ordered with the instrument. Contact your Tektronix Sales Engineer, Distributor, or Representative for information.

INTERNATIONAL POWER CORDS AND PLUG OPTIONS

- Option A1 Universal Euro 220 V/16A** No Charge
- Option A2 UK 240 V/13A** No Charge
- Option A3 Australian 240 V/10A** No Charge
- Option A4 North American 240 V/15A** No Charge

For information on hoods, covers, filters, carts, battery packs, rack adapter, and cameras, see previous page.

TEK 100 MHz DUAL TRACE TRI-SERVICE STANDARD OSCILLOSCOPE

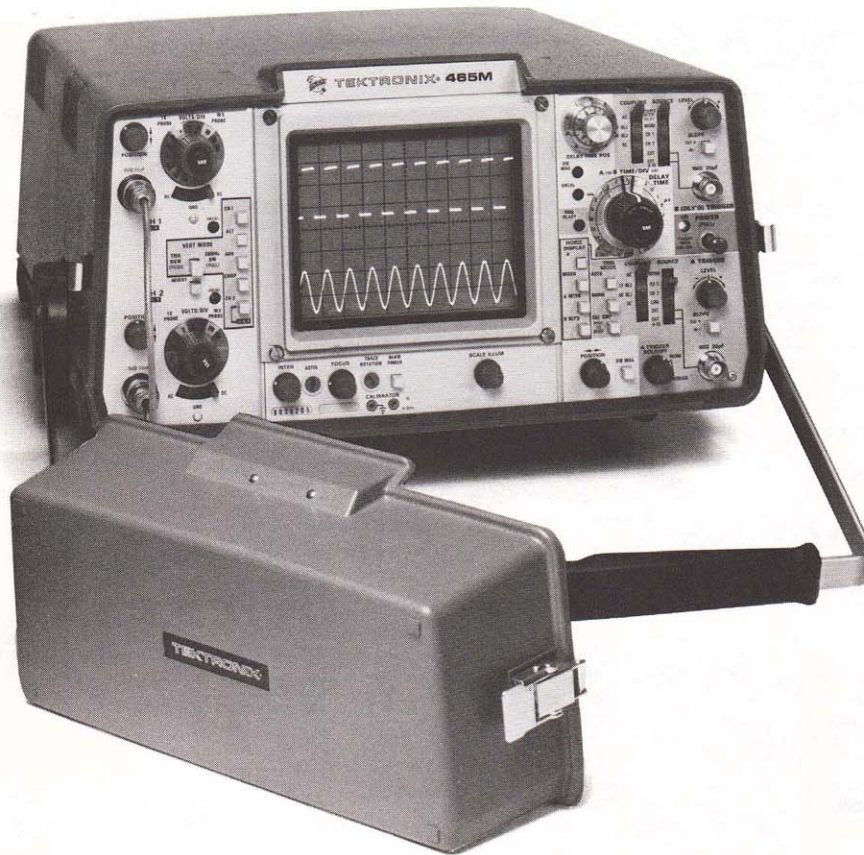

465M (AN/USM)425 (v) 1

Fully Provisioned through the Federal Supply System

Meets MIL-T-28800, Type II, Class 4, Style C for the Environmental Conditions Listed

100 MHz at 5 mV/div, Dual Trace, Delayed Sweep

Accepted and Specified by All Branches of the Military and by Several Civil Agencies

If you're a contractor involved in designing and specifying systems for the government, here's a 100 MHz oscilloscope that should top your recommended support equipment list—the TEKTRONIX 465M Portable Oscilloscope.

The TEKTRONIX 465M is the AN/USM-425 (v) 1 tri-service standard 100 MHz portable oscilloscope. The instrument is accepted, fully provisioned, and supported throughout the Federal Supply System. Because the MIL manuals and support documentation are already complete, your required paper work is greatly reduced and it's much simpler for the government to accept your recommendations.

You can now order the 465M directly from your Tektronix Sales Engineer with the AN/USM 425 (v) 1 nomenclature by simply specifying option 49. This assures the fastest possible delivery of your AN/USM 425 (v) 1.

CHARACTERISTICS

VERTICAL SYSTEM

Bandwidth and Rise Time — Dc to at least 100 MHz (-3 dB) and rise time 3.5 ns or less for dc coupling and -15°C to $+55^{\circ}\text{C}$. For ac coupling the lower 3 dB point is 10 Hz or less with a 1X probe and 1 Hz or less with a 10X probe.

Bandwidth Limit Mode — Bandwidth limited to 20 MHz.

Deflection Factor — 5 mV/div to 5 V/div in 10 steps (1-2-5 sequence). Dc accuracy: $\pm 2\%$ 0°C to $+40^{\circ}\text{C}$; $\pm 3\%$, -15°C to 0°C , $+40^{\circ}\text{C}$ to $+55^{\circ}\text{C}$. Uncalibrated, continuously variable between settings, and to at least 12.5V/div.

Common-Mode Rejection Ratio — 25:1 to 10 MHz; 10:1 from 10 to 50 MHz, 6 cm sinewave, (ADD Mode with Ch 2 inverted.)

Display Modes — Ch 1, Ch 2 (normal or inverted), alternate, chopped (250 kHz rate), added, X-Y.

Input R and C — 1 M Ω $\pm 2\%$, ≈ 20 pF.

Max Input Voltage — Dc or ac coupled: ± 250 V dc + peak ac at 50 kHz, derated above 50 kHz.

Cascaded Operation — (Ch 2 Out into Ch 1), Bandwidth, dc to at least 40 MHz. Sensitivity, ≈ 1 mV/div when terminated in 50 Ω at Ch 1 input with both Ch 1 and Ch 2 V/div switches set to 5 mV/div.

HORIZONTAL DEFLECTION

Time Base A — 0.5 s/div to 0.05 $\mu\text{s}/\text{div}$ in 22 steps (1-2-5 sequence). X10 mag extends fastest sweep rate to 5 ns/div.

Time Base B — 50 ms/div to 0.05 $\mu\text{s}/\text{div}$ in 19 steps (1-2-5 sequence). X10 mag extends fastest sweep rate to 5 ns/div.

Accuracy—

| | Unmagnified | Magnified |
|----------------|-------------|-----------|
| +20°C to +30°C | $\pm 2\%$ | $\pm 3\%$ |
| -15°C to +55°C | $\pm 3\%$ | $\pm 4\%$ |

Mixed Sweep Accuracy — A portion— $\pm 4\%$.
B portion— $\pm 2\%$.

Horizontal Display Modes — A, A intensified by B, B delayed by A, and mixed.

CALIBRATED SWEEP DELAY

Calibrated Delay Time — Continuous from 0.1 μs to at least 5 s after the start of the delaying A sweep.

Differential Time Measurement Accuracy — for measurements of two or more major dial divisions: $+15^{\circ}\text{C}$ to $+35^{\circ}\text{C}$, 1% + 0.1% of full scale 0°C to $+55^{\circ}\text{C}$, additional 1% allowed.

Jitter — 1 part or less in 20,000 (0.005%) of X10 the A TIME/DIV switch setting.

TRIGGERING A AND B

A Trigger Modes — Normal Sweep is triggered by an internal vertical amplifier signal, external signal, or internal power line signal. A bright baseline is provided only in presence of trigger signal. Automatic: A bright baseline is displayed in the absence of input signals. Triggering is the same as normal-mode above 40 Hz. Single (main time base only): The sweep occurs once with the same triggering as normal. The capability to re-arm the sweep and illuminate the reset lamp is provided. The sweep activates when the next trigger is applied for rearming.

A Trigger Holdoff — Increases A sweep holdoff time to at least X10 the TIME/DIV settings, except at 0.2 s and 0.5 s.

Triggering Sensitivity and Coupling —

| Coupling | | From 30 Hz | At 100 MHz |
|--------------|--------------------------|------------|------------|
| | | to 25 MHz | |
| Dc | Internal | 0.3 div | 1.0 div |
| | External | 50 mV | 150 mV |
| Ac | Attenuates signals below | 30 Hz | |
| Ac Lf Reject | Attenuates signals below | 15 kHz | |
| Ac Hf Reject | Attenuates signals below | 50 kHz | |

Jitter — 0.5 ns or less at 100 MHz and 5 ns/div, -15°C to +55°C.

Trigger View — View external and internal trigger signals; Ext 1X, 100 mV/div, Ext ÷10, 1 V/div.

Level and Slope — Internal, permits triggering at any point on the positive or negative slopes of the displayed waveform. External, permits continuously variable triggering on any level between +1.0 V and -1.0 V on either slope of the trigger signal.

A Sources — Ch 1, Ch 2, NORM (all display modes triggered by the combined waveforms from Ch 1 and 2), LINE, EXT, EXT ÷10.

B Sources — B starts after delay time; Ch 1, Ch 2, NORM, EXT, EXT ÷10.

X-Y OPERATION

Sensitivity — 5 mV/div to 5 V/div in 10 steps (1-2-5 sequence) through the vertical system. Continuously variable between steps and to at least 12.5 V/div.

X Axis Bandwidth — Dc to at least 4 MHz.

Y Axis Bandwidth — Dc to 100 MHz.

X-Y Phase — <3° from dc to 50 kHz.

SIGNAL OUTPUTS

A Gate — ≈5.0 V positive-going pulse.

B Gate — ≈5.0 V positive.

DISPLAY

CRT — 5 in, rectangular tube; 8 x 10 cm display; P31 Phosphor.

Graticule — Internal, non-parallax; illuminated. 8 x 10 cm markings with horizontal and vertical centerlines further marked in 0.2 cm increments. 10% and 90% markings for rise time measurements.

Graticule Illumination — Provides variable illumination from 0 to greater than optimum illumination.

Beam Finder — Limits the display to within the graticule area and provides a visible display when pushed.

Z-Axis Input — A female BNC connector is provided to permit intensity modulation over the dc to 15 MHz range. At optimum intensity, intensity modulation is accomplished with a Z axis input of from -5 V (to intensify) to +5 V (to blank). Continuous operation maximum input shall be ±50 V (dc + peak ac).

ENVIRONMENTAL

Emc — Complies with the following limits as specified in MIL-T-28800B. CE01 (10 kHz to 20 kHz only), CE03, CS01, CS02, CS06, RE01 (relaxed 10 dB at fundamental, third harmonic, and fifth harmonic of the power source frequency) RE02 (limited to 7 GHz), RS01 and RS03 (limited to 1 GHz).

Ambient Temperature — Operating: -15°C to +55°C. Non-operating: -62°C to +85°C.

Altitude — Operating: to 15,000 feet. Max operating temperature decreased 1°C/1,000 ft above 5,000 ft. Nonoperating: to 50,000 ft.

Vibration — Operating: along each of the three major axes: a. cycling 5 to 25 to 5 Hz for 10 min at 0.025 in p-p; b. cycling 25 to 55 to 25 Hz for 5 min at 0.020 in p-p; c. dwelled at 55 Hz for 10 min at 0.020 in p-p. Total vibration time 75 min.

Humidity — Five cycles (120 hours) referenced to MIL-E-16400F (operating and nonoperating).

Shock — Operating: 30 g's, 1/2 sine, 11 ms duration, 3 shocks each direction per axis for a total of 18 shocks.

OTHER CHARACTERISTICS

Calibrator Output Voltage — 1.0 V ±1.0% to -15°C to +55°C. Frequency ≈1 kHz.

Channel 2 Signal Output — Through main module Ch 2 OUT connector. Output voltage: ≈50 mV/div into 1 MΩ, ≈25 mV/div into 50 Ω. Output resistance: ≈50 Ω. Bandwidth: dc to at least 40 MHz into 50 Ω.

Power Requirements — 100 V to 132 V RMS, 200 V to 264 V RMS. 48 Hz to 440 Hz. Maximum power consumption 60 watts at 115 V, 60 Hz.

PHYSICAL CHARACTERISTICS

| Dimensions | cm | in |
|--|-------|-------|
| Height (with feet) | 17.91 | 7.05 |
| Width (with handle) | 34.67 | 13.65 |
| Width (without handle) | 31.75 | 12.50 |
| Depth (including panel cover) | 54.58 | 24.45 |
| Depth (handle extended) | 61.10 | 24.10 |
| Weight (approx) | kg | lbs |
| Net (without cover and accessories) | 10.9 | 24.0 |
| Net (with panel cover, modules, and accessories) | 12.2 | 27.0 |
| Shipping | 15.5 | 34.2 |

Transportation — Meets the limits of National Safe Transit Committee test procedure 1A with a 30 in drop.

INCLUDED ACCESSORIES

One accessory and cover assembly (200-2055-01), one 1X probe (010-6101-00), two 10X probes (010-6104-00), three pincer tips (013-0107-03), two UHF male to BNC female adapters (103-0015-00), two BNC male to UHF female adapters (103-0032-00), one T connector (103-0030-00), one BNC male to dual binding post adapter (103-0035-00), three probe tip adapters (103-0051-01), three banana tips (134-0013-00), three 6 in. leads with spring clips (175-0124-01), three hooked probe tips (206-0105-00), one blue filter (337-2122-00), one clear filter (337-2122-01), three miniature alligator clips (344-0046-00), one power cord (161-0118-00).

ORDERING INFORMATION

465M Portable Oscilloscope \$3500
Option 49 AN/USM 425 (v)1 No Charge

INTERNATIONAL POWER CORDS AND PLUG OPTIONS

Option A1 Universal Euro 220 V/16A No Charge
Option A2 UK 240 V/13A No Charge
Option A3 Australian 240 V/10A No Charge
Option A4 North American 240 V/15A No Charge

OPTIONAL ACCESSORIES

Probe — P6022 Current Probe, 9 ft cable with termination.
Order 015-0135-01 \$325
Folding Polarized Viewing Hood
Order 016-0180-00 \$40
Mesh Filter — Improves contrast and emc filtering.
Order 378-0726-01 \$45
SCOPE-MOBILE® Cart — Occupies <18 in of aisle space.
Order 200C \$265
Rack Adapter (Cradle Mount) Kit — Rack height 7 in, depth 18.75 in, width 19 in **Order 040-0825-01** \$320

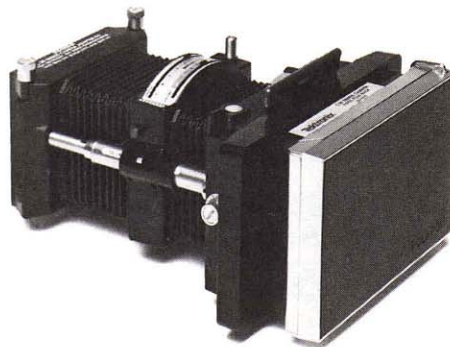

RECOMMENDED CAMERA

C-30 BP Option 01 General Purpose Camera — Includes 016-0301-00 mounting adapter/corrector lens.
Order C-30BP Option 01 Camera \$1285
 For further information see camera section.

Tektronix offers maintenance training classes on instruments in the 400 Series and multi-media training packages on Digital Counter and Meter Concepts and Basic Oscilloscope Maintenance Concepts. For further training information, contact your local Sales Office or request a copy of the Tektronix Customer Training Catalog on the return card.



1105 BATTERY POWER SUPPLY

The 1105 is a rugged, portable power supply suitable for powering virtually any portable oscilloscope in the field. The 1105 is not recommended for the T912.

Frequency — Squarewave, 60 Hz ±10%.
Amplitude — ≈108 V peak, operating from 24 V dc external or 22 V internal charge. ≈137.5 V peak, operating from 28 V dc external or 30 V internal charge.
Amplitude (Option 01) — ≈216 V peak, from 24 V dc external or 22 V internal charge. ≈275 V peak, operating from 30 V dc external or 28 V internal charge.
Charging Power Source — 100 to 132 V ac, 48 to 440 Hz (or internal connections expand range). Option 01 — 200 to 264 V ac, 48 to 440 Hz (or internal connections expand range).
Battery Operating Time — ≈100 W hrs.
Recommended Max Output Current — 0.9 A.
Weight — 8.8 kg (19.5 lb).

Order 1105 Battery Power Supply \$1240
Option 01, 230 V Operation No Charge

SONY®/TEKTRONIX® 35 MHz DUAL TRACE OSCILLOSCOPE

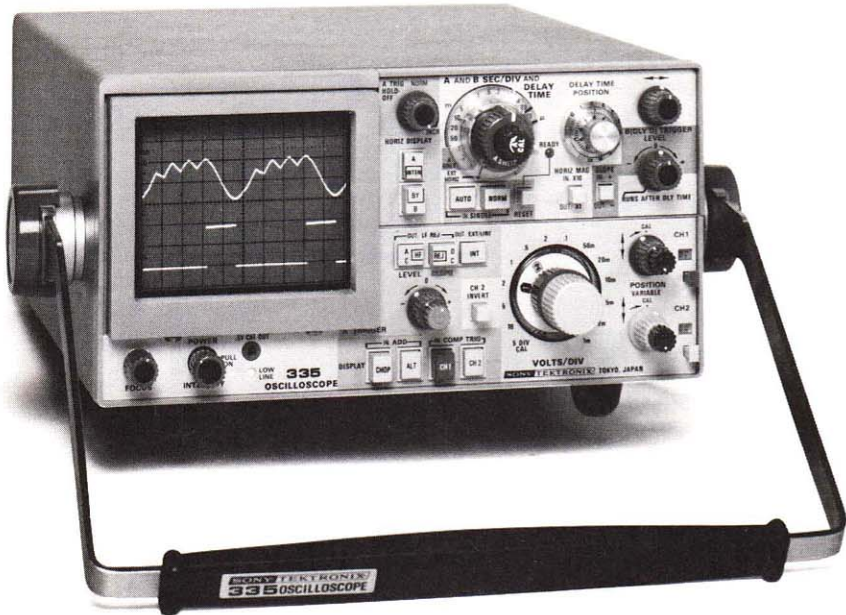

335

35 MHz at 10 mV/div

Small Size, Weighs ≈ 4.7 kg, (10.5 lb)

1 mV/div Vertical Sensitivity at 25 MHz

Delay Lines Input

Rugged Construction

The portability of the 335 is a big plus in many digital and analog trouble-shooting applications. And it weighs only 10.5 pounds.

1 mV/div (at 25 MHz) vertical sensitivity insures that low level signals from magnetic recording heads, optical read heads, or industrial control transducers can be accurately and easily measured. Delay line allows viewing the leading edge of the triggering signal. By using a composite of Channels 1 and 2 as a trigger source, stable displays of non-time-related signals can be obtained.

Operation from either ac (90 to 132 V, or 180 to 264 V, 48 to 440 Hz) or dc (+11 to +14 V or +22 to +28 V) assures that power can be obtained at nearly any location.

VERTICAL DEFLECTION (2 Identical Channels)

| Bandwidth — | |
|-------------------------------|----------------|
| +20°C to +30°C | -15°C to +55°C |
| 1 mV to 5 mV/div dc to 25 MHz | dc to 20 MHz |
| 10 mV to 5 V/div dc to 35 MHz | dc to 30 MHz |
| 10 V/div dc to 25 MHz | dc to 20 MHz |

For ac coupling, the lower 3 dB point is 10 Hz or less with a 1X probe and 1 Hz or less with a 10X probe.

Deflection Factor — 1 mV/div to 10 V/div (1-2-5 sequence) accurate ±3%. Uncalibrated, continuously variable between steps and to at least 25 V/div.

Display Modes — Ch 1, Ch 2 (normal or inverted) alternate, chopped (≈ 300 kHz rate) added, X-Y.

Input R and C — 1 MΩ ± 2%, paralleled by ≈ 24 pF.

Max Input Voltage, ac or dc coupled, 300 V (dc + peak ac). 300 V p-p ac at 1 kHz or less.

Delay Line — Permits viewing leading edge of displayed waveform.

HORIZONTAL DEFLECTION

Time Base A — 0.2 μs/div to 0.5 s/div (1-2-5 sequence). X10 magnifier extends fastest sweep rate to 20 ns/div.

Time Base B — 0.2 μs/div to 50 ms/div (1-2-5 sequence). X10 magnifier extends fastest sweep rate to 20 ns/div.

Variable Time Control — Time Base A provides uncalibrated, continuously variable sweep rates between steps and to at least 1.25 s/div.

Time Base A and B Accuracy, center 8 div —

| | +20°C to +30°C | -15°C to +55°C |
|-------------|----------------|----------------|
| Unmagnified | ±3% | ±4% |
| Magnified | ±5% | ±6% |

Horizontal Display Modes — A only. A intensified by B, B delayed by A, B triggerable after A.

CALIBRATED SWEEP DELAY

Delay Time Range — Continuously variable from 1 μs to at least 5 s after the start of the delaying (A) sweep.

Differential Time Measurement Accuracy —

| Delay Time Settings between 1.0 and 9.0 | +15°C to +35°C |
|---|----------------|
| one or more major dial divisions | ±2% |
| less than one major dial divisions | ±0.02% |

Jitter — 1 part or less in 20,000 (0.005%) of X10 the A time/div setting.

TRIGGERING A AND B

A Trigger Modes — Normal (sweep runs when triggered). Automatic (sweep free-runs in absence of a triggering signal and for signals below 20 Hz). Single sweep (sweep runs once on the first trigger signal after the reset button is pushed).

Variable Trigger Holdoff — For the A sweep an adjustable holdoff control permits a stable display of complex waveforms. Sweep holdoff time can be increased at least X10.

B Trigger Modes — B runs after delay time (starts automatically at the end of the delay time). B triggerable after delay time (runs when triggered). The B (delayed) sweep runs once in each of these modes, following the A sweep delay time.

Trigger Sensitivity and Coupling —

| Coupling | | To 10 MHz | At 35 MHz |
|-----------|---|-----------|-----------|
| Dc | Internal | 0.35 div | 1.5 div |
| | External | 70 mV | 250 mV |
| | Ext ÷ 10 | 700 mV | 2.5 V |
| Ac | above requirements increase below 60 Hz | | |
| Ac Hf Rej | requirements increase above 20 kHz | | |
| Ac Lf Rej | requirements increase below 40 kHz | | |

Trigger Sources — Internal Ch 1, internal Ch 2, internal composite (uses a composite of Ch 1 and Ch 2 signals to produce trigger), external, external ÷ 10, and line. The B sweep can also be started automatically at the end of the time base A delay.

X-Y OPERATION

Input — X-axis input is via the external horizontal input connection. Both Ch 1 and Ch 2 provide vertical inputs. Using chopped mode, two simultaneous X-Y displays can be obtained.

X-Axis Deflection Factors — Variable from ≈ 20 mV/div to ≈ 2 V/div. Dc to at least 500 kHz.

Input Impedance — ≈ 1 MΩ paralleled by 24 pF.

DISPLAY

CRT — 8 x 10 div (0.6 cm/div) display. P31 Phosphor. 12 kV accelerating potential.

Graticule — Internal (non-parallax) non-illuminated. Vertical and horizontal centerlines marked in 5 minor div per major 0.6 cm.

Z-Axis Input — +5 V signal causes noticeable modulation at normal intensity. Useful bandwidth dc to 600 kHz.

ENVIRONMENTAL CAPABILITIES

Ambient Temperature — Operating: -15°C to +55°C. Nonoperating: -40°C to +75°C.

Altitude — Operating: to 15,000 ft max, decrease max temperature by 1°C/1000 ft from 5000 ft to 15,000 ft. Nonoperating: to 50,000 ft max.

Vibration — Operating and nonoperating: 15 minutes along each of the three major axes, 0.06 cm (0.025 in) p-p displacement (4 g's at 55 Hz) 10 to 55 to 10 Hz in 1-minute cycles.

Humidity — 5 cycles (120 hours) referenced to MIL-E-16400 F.

Shock — Operating and nonoperating: 30 g's, 1/2 sine, 11 ms duration each direction along each major axis. Total of 12 shocks.

OTHER CHARACTERISTICS

Amplitude Calibrator — 0.5 V (±1%) ≈ 1 kHz from 20°C to 30°C.

Power Source — External ac source, 90 V to 132 V or 180 V to 264 V with a line frequency of 48 Hz to 440 Hz. Max power dissipation 24 W at 115 V. External dc source: +11 V to +14 V or +22 V to +28 V with a max current drain of 2 A at +12 V or 1.0 A at +24 V.

PHYSICAL CHARACTERISTICS

| Dimensions | PHYSICAL CHARACTERISTICS | |
|-----------------------------|--------------------------|-----------|
| | cm | in |
| Height | 11.2 | 4.4 |
| Width (with handle) | 23.6 | 9.3 |
| Depth (handle not extended) | 34.7 | 13.6 |
| Depth (handle extended) | 44.8 | 17.6 |
| Weights (approx) | kg | lb |
| Net (without accessories) | 4.7 | 10.5 |
| Shipping | 7.6 | 17.0 |

INCLUDED ACCESSORIES

Two P6149 10X probes (010-6149-03), carrying case and pouch (016-0485-00), external dc cable assembly (012-0406-00), strap assembly (346-0131-00), two 1-A fuses (159-0064-00), two 0.4-A fuses (159-0139-00), two 2-A fuses (159-0107-00), three 0.2-A fuses (159-0080-00).

ORDERING INFORMATION

335 Portable Oscilloscope\$2760

OPTIONAL ACCESSORIES

Viewing Hood — Order 016-0297-00\$6.50
CRT Filter — Light blue. Order 378-2016-01\$1.80
CRT Filter — Light amber. Order 378-0843-01\$1.80
CRT Mesh Filter — With frame and holder.
 Order 378-0063-00\$27

The SONY®/TEKTRONIX® 335 is manufactured and marketed in Japan by Sony/Tektronix Corporation, Tokyo, Japan. Outside of Japan, the 335 is available from Tektronix, Inc., its marketing subsidiaries and distributors.

RECOMMENDED CAMERA

C-30BP General Purpose Camera\$1245
Camera Adapter — mounts C-30B to 335.
 Order 016-0327-01\$165
 For further information see Camera section.

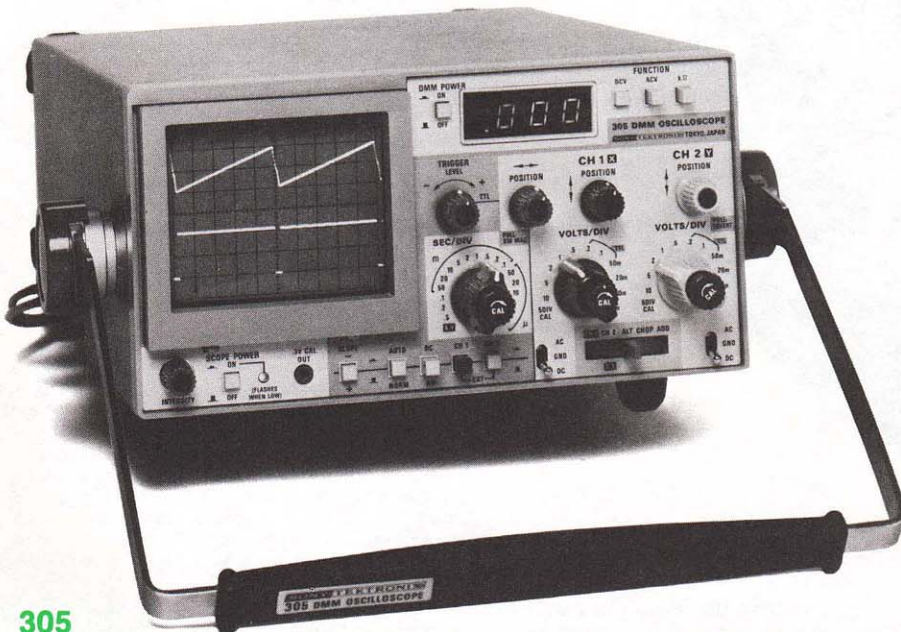

305

5 MHz at 5 mV/div Full X-Y
Dual-Trace Weighs ≈ 10.6 lb

The 305 Oscilloscope/DMM is the ideal oscilloscope for those who demand portability and multi-function versatility in their test instrumentation.

The SONY®/TEKTRONIX® 305 combines a 5 MHz oscilloscope with an integral auto ranging DMM and a built-in rechargeable battery pack. Take the 305 instead of multiple instruments when you climb the ladder to maintain your in-plant industrial controls. Or leave the extension cord at your bench when you go on location to service medical instrumentation.

The 305 features a dual-trace 5 MHz oscilloscope with a large 8 x 10 div (0.6 cm/div) CRT display and an autoranging DMM with dc and ac volts, and resistance measurement functions—all in a 10.6 lb (4.8 kg), 4.4 x 9.3 x 14.6 inch (11.2 x 23.6 x 37.1 cm) package. The front panel TTL marker presents the trigger generator for optimum level control on TTL signals.

VERTICAL DEFLECTION

Bandwidth — Dc to at least 5 MHz. For ac coupling, the lower 3 dB point is ≈ 10 Hz.

Deflection Factor — 5 mV/div to 10 V/div (1-2.5 sequence) accurate ±3% from 0°C to +40°C, ±4% through remainder of operating range. Uncalibrated, continuously variable between steps and to at least 25 V/div.

Display Modes — Ch 1, Ch 2, Chopped, Alternate, Added, Invert Ch 2 and X-Y. Bandwidth in Add mode is dc to at least 4.5 MHz.

Input R & C — 1 MΩ ±2%, paralleled by ≈47 pF.

Max Input Voltage — ac or dc coupled, 250 V (dc + peak ac), or 250 V p-p at <1 kHz.

HORIZONTAL DEFLECTION

Time Base — 500 ms/div to 1 μs/div (1-2.5 sequence). X10 mag extends sweep rate to 0.1 μs/div.

Variable Time Control — Uncalibrated, continuously variable between steps and to at least 1.25 s/div.

Time Base Accuracy, Center 8 div —

| | 0°C to +40°C | -15°C to +55°C |
|-------------|--------------|----------------|
| Unmagnified | ±3% | ±4% |
| Magnified | ±5% | ±6% |

(Excludes first 10 div and all sweep past 90 div in X10 mag.)

TRIGGER

Modes — Normal and Auto (p-p).

TTL Triggering — TTL position of trigger level control presets for optimum triggering from TTL levels, in 50 mV, 0.1 V and 0.2 V/div or external trigger signals.

Trigger Sources — Internal Ch 1, internal Ch 2, external. TTL Threshold voltage, int (with 10X probe) 1.4 V within ±0.3 V, Ext (with 10X probe) 1.4 V within ±0.2 V.

Trigger Sensitivity in NORMAL-Mode

| Coupling | Mode | To 0.5 MHz | At 5 MHz |
|----------|---|------------|----------|
| Dc | Internal | 0.3 div. | 0.75 div |
| | External | 15 mV | 50 mV |
| Ac | Above requirements increase below 60 Hz | | |

P-P Auto Operation Sensitivity

| Coupling | Mode | 500 Hz to 0.5 MHz | 0.5 MHz to 5 MHz |
|----------|----------|-------------------|------------------|
| Dc, Ac | Internal | 0.5 div | 1.0 div |
| | External | 35 mV | 70 mV |

External Trigger — Max Input Voltage: 250 V (dc + peak ac) at 1 kHz or less (same as vertical). Input R and C, ≈1 MΩ paralleled by ≈47 pF.

X-Y OPERATION

Input — X-axis input is via the Ch 1 connector; Y-axis input is via the Ch 2 connector.

X-Y Characteristics — Same as stated for vertical deflection, except deflection factor accuracy is ±4% from 0°C to +40°C over the center 8 div.

X-Axis Bandwidth — Dc to 150 kHz.

DISPLAY

CRT — 8 x 10 div (0.632 cm/div) display. P31 Phosphor. 2 kV accelerating potential.

Graticule — Internal, non-illuminated.

DMM

DC VOLTAGE

Ranges — 2 V, 20 V, 200 V, 1000 V (autoranging).

Accuracy — Within 0.1% of reading, ±2 counts.

Common-Mode Rejection — >100 dB at dc, 80 dB at 60 Hz with 1 kΩ imbalance.

Normal-Mode Rejection — >30 dB at 60 Hz increasing 20 dB per decade to 2 kHz.

Response — <1 s plus range step time (<1 s/step).

Input R — 10 MΩ ±2%.

AC VOLTAGE

Ranges — 2 V, 20 V, 200 V, 700 V, (autoranging).

Accuracy — Within 0.5% of reading, ±10 counts, 40 Hz to 500 Hz.

Response Time — <5 s plus range step time (<1 s/step).

Input Impedance — 10 MΩ paralld by ≈70 pF.

RESISTANCE

Ranges — 2 kΩ, 20 kΩ, 200 kΩ, 2000 kΩ.

Accuracy — Within 0.6% of reading ± 3 counts.

Response Time — <5 s plus range step time (<1 s/step). Max safe input voltage at DMM input connectors—DcV: 1000 V dc + peak ac, between HI and LO inputs or between HI and chassis.

ACV — 700 V RMS if sinusoidal between HI and LO inputs or between HI and chassis, +1000 V dc + peak ac between HI and LO inputs or between HI and chassis, +500 V (dc component) between LO and chassis, kΩ function settling: 100 V (dc + peak ac) between HI and LO inputs.

All Ranges — 500 V (dc + peak ac) between LO and chassis (LO Floating Voltage).

ENVIRONMENTAL CAPABILITIES

Ambient Temperature — Operating: -15°C to +55°C (Oscilloscope), 0°C to +55°C (DMM). Nonoperating: -25°C to +75°C.

Altitude — Operating: to 30,000 ft max, decrease max temperature by 1°C/1000 ft from 5,000 ft to 30,000 ft. Nonoperating: 50,000 ft max.

Vibration — 15 min along each of the three major axes, 0.025 in (0.06 cm) p-p displacement (4 g's at 55 Hz) 10 to 55 to 10 Hz in 1 min cycles.

Humidity — Nonoperating: 5 cycles (120 hrs) of MIL-E-16400G. Omit freezing and vibration and allow a post-test drying period at +25°C, ±5°C and 20% to 80% relative humidity.

Shock — Operating and nonoperating: 30 g's, 1/2 sine, 11 ms duration. Total of 12 shocks.

OTHER CHARACTERISTICS

Amplitude Calibrator — 0.3 V accurate ±1% from 20°C to 30°C ±2% from -15°C to +55°C.

Power Sources — External ac source, 90 V to 132 V or 180 V to 250 V with a line frequency of 48 Hz to 440 Hz. Max power dissipation of 17 W. External dc source +9 V to +32 V.

Charge Time — At least 16 hours for full charge.

Operating Time — Internal NiCd batteries provide ≈1.6 hours of scope and DMM operation, 10 hours of DMM alone operation, or 2 hours of scope alone operation at maximum trace intensity and 20°C to 25°C operating temperature.

PHYSICAL CHARACTERISTICS

| Dimensions | cm | in |
|-----------------------------|-----------|-----------|
| Height | 11.2 | 4.4 |
| Width (with handle) | 23.6 | 9.3 |
| Depth (handle not extended) | 37.1 | 14.6 |
| Depth (handle extended) | 45.8 | 18.0 |
| Weights (approx.) | kg | lb |
| Net (without accessories) | 4.8 | 10.6 |
| Shipping | 7.8 | 17.1 |

INCLUDED ACCESSORIES

Two 10X probes (010-6149-03), one DMM probe package (012-0732-00), one carrying case (016-0401-00), one carrying case cover (200-2260-00), one carrying strap assembly (346-0131-00), one clear CRT filter (331-0394-01), one blue CRT filter (378-2016-01), one external dc cable assembly (012-0406-00).

ORDERING INFORMATION

305 DMM/Oscilloscope \$2120

The SONY®/TEKTRONIX® 305 DMM/Oscilloscope is manufactured and marketed in Japan by Sony/Tektronix Corporation, Tokyo, Japan. Outside of Japan the 305 is available from Tektronix, Inc., its marketing subsidiaries and distributors.

OPTIONAL ACCESSORIES

Viewing hood (016-0297-00) \$6.50
BNC to binding post adapter (103-0033-00) \$4.75

RECOMMENDED CAMERA

C-30BP General Purpose Camera \$1245
Camera Adapter Mount C-30B to 305

Order 016-0327-01 \$165

For further information see Camera section.

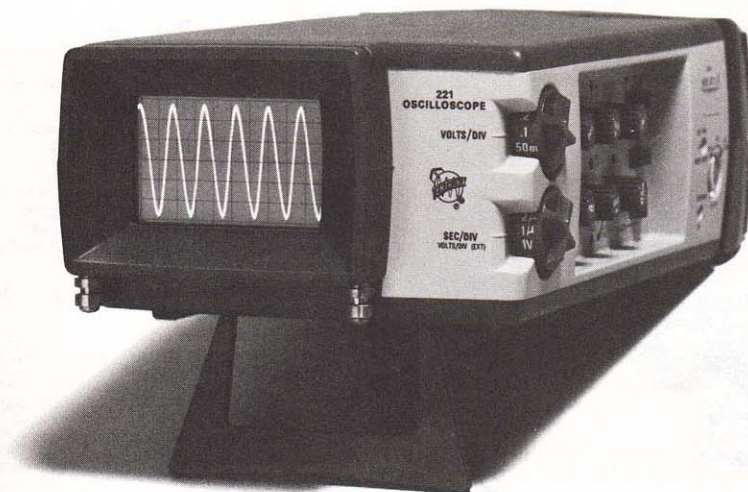

221

5 MHz, 5 mV/div to 100 V/div

**0.1 μs/div Sweep Rate with
X10 Sweep Magnifier**

Internal Battery Pack

Integral 1 MΩ Probe

Weights ≈ 1.6 kg,(3.5 lb)

The 221 Miniscope weighs just 3.5 pounds and easily fits into a tool box or brief case; it measures only 3 x 5.2 x 9 inches. Yet it has the capability needed for on-site service of much of today's complex equipment. This versatile miniscope has a 5 MHz bandwidth, 5 mV/div sensitivity, and 0.1 μs/div sweep rate (using X10 magnifier) packaged in an impact-resistant case.

Internal rechargeable batteries allow at least two hours operation away from external power sources. And the 221 will operate and charge from practically all the world's principal line voltages: 90 to 250 V, 48 to 62 Hz ac, or 80 to 250 V dc (all without making any change to the instrument).

The 1 MΩ low-capacitance probe minimizes circuit loading. And because it's attached, it's always there when you need it. Vertical deflection factors extend from 5 mV/div, allowing on-screen measurement of signals up to 600 V dc + peak ac. The 1 μs/div to 200 ms/div time base is enhanced by a X10 magnifier that extends the fastest range to 0.1 μs/div. A variable control will slow the sweep to about 0.5 s/div.

A single rotary control on the 221 is used for all trigger level and slope functions. Controls are side mounted and recessed for protection, yet are easily accessible.

In applications where it is necessary to "float" the oscilloscope to make your measurements, 200 Series Miniscopes can be elevated to 700 V (dc + peak ac) above ground when operated from batteries. Although insulated, caution should be observed when connecting the probe to test points.

The 221 is used in a wide assortment of service applications. For example, in data transmission systems, the 221 is preferred for maintenance and testing of modems because of its ability to see higher frequency noise. It can even help in building roads by spot checking motors in a road grader's closed loop servo system that controls blade angle, depth of cut and machine direction.

VERTICAL DEFLECTION

Bandwidth — Dc to 5 MHz (−3 dB point) at all calibrated deflection factors. Lower −3 dB point ac coupled is ≈2 Hz.

Deflection Factor — 5 mV/div to 100 V/div, accurate ±3% from 0°C to +40°C and ±5% from −15°C to 0°C and +40°C to +55°C. Uncalibrated, continuously variable between steps to at least 300 V/div.

Input R and C — ≈1 MΩ paralleled by ≈29 pF via attached signal acquisition probe.

Max Input Voltage — 600 V (dc + peak ac), 600 V p-p ac, 5 MHz or less.

HORIZONTAL DEFLECTION

Time Base — 1 μs/div to 200 ms/div, accurate ±3%.

Magnifier — Increases all sweep speeds X10 with a max sweep speed of 0.1 μs/div.

Variable Time Control — Extends minimum sweep rate to ≈0.5 s/div. Continuously variable between calibrated settings.

TRIGGER

Modes — Automatic or manual. Level and slope selected with a single control. Automatic operation minimizes trigger adjustment and provides a bright baseline with no input.

Trigger Sensitivity —

| Mode | To 1 MHz | At 5 MHz |
|----------|----------|----------|
| Internal | 0.5 div | 1 div |
| External | 0.5 V | 1 V |

X-Y OPERATION

Input — X-axis input is via the external trigger or the external horizontal input.

X-Axis Deflection Factor — 1 V/div ±10%, dc to 500 kHz. Sensitivity is increased by a factor of 10 (0.1 V/div) using horizontal magnifier.

Max External Horizontal Input Voltage — 200 (dc + peak ac), 200 V (p-p ac) to 500 kHz, decreasing to 20 V p-p ac at 5 MHz.

Input Impedance — ≈0.5 MΩ paralleled by ≈30 pF.

DISPLAY

CRT — 6 x 10 div (0.5 cm/div) display. P31 Phosphor normally supplied; P7 optional. 1 kV accelerating potential.

Graticule — Internal, black line, non-illuminated.

ENVIRONMENTAL CAPABILITIES

Ambient Temperature — Operating: (battery only), −15°C to +55°C. Charging or operating from ac line: 0°C to +40°C. Nonoperating: −40°C to +60°C.

Altitude — Operating: 25,000 ft, decrease max temperature by 1°C/1000 ft above 15,000 ft. Nonoperating: 50,000 ft.

Vibration — Operating and nonoperating: 15 minutes along each of the 3 major axes, 0.06 cm (0.025 in) p-p displacement (4 g's at 55 Hz) 10 to 55 to 10 Hz in one minute cycles. Held for 3 min at 55 Hz.

Humidity — 5 days at +50°C, 95% humidity.

Shock — Operating and nonoperating: 100 g's, 1/2 sine, 2 ms duration each direction along each major axis. Total of 12 shocks.

OTHER CHARACTERISTICS

Power Sources — Internal NiCd batteries provide at least 2 hours operation at max trace intensity for a charging and operating temperature between +20°C and +30°C. Internal charger charges the batteries when connected to an ac line with instrument turned on or off. Dc operation is automatically interrupted when battery voltage drops to ≈10 V to protect batteries against deep discharge. Full recharge requires ≈16 hours. Extended time charges will not damage the batteries. An expanded scale battery meter indicates full, low, and recharge. External power source, 90 to 250 V ac (48 to 62 Hz) or 80 to 250 V dc, 5 W or less.

Insulation Voltage — 500 V RMS or 700 V (dc + peak ac) when operated from internal batteries, with the line cord stored and the plug protected. When operated from an external line, line voltage plus floating voltage not to exceed 250 V RMS; or 1.4 x line + (dc + peak ac) not to exceed 350 V.

PHYSICAL CHARACTERISTICS

| Dimensions | cm | in |
|---------------------------|-----------|-----------|
| Height | 7.6 | 3.0 |
| Width | 13.3 | 5.2 |
| Depth | 22.8 | 9.0 |
| Weights (approx) | kg | lb |
| Net (without accessories) | 1.6 | 3.5 |
| Shipping | ≈3.6 | ≈8.0 |

INCLUDED ACCESSORIES

Viewing hood (016-0199-01), carrying case (016-0512-00), neck strap (346-0104-00), two spare fuses (159-0080-00).

ORDERING INFORMATION

221 Oscilloscope, including batteries and probe \$1600

INSTRUMENT OPTION

Option 76 P7 Phosphor Add \$35

OPTIONAL ACCESSORIES

Alligator Clip Kit — A pair of alligator clips that allow connecting the probe and ground lead to large (up to 3/8 in) conductors. Includes: red clip (015-0229-00); yellow clip (015-0230-00); 6-32 to probe adapter (103-0051-01).
Order 015-0231-00 \$16

Probe-tip to BNC Panel Connector Adapter
Order 013-0084-01 \$8.00

Probe-tip to BNC Cable Adapter,
Order 103-0096-00 \$10.50

Power Cable Adapter Assembly — A short length of two-wire power cord. One end has a female NEC socket fitting the 200 Series power cords; the other end is left open so that the wires can be attached to a non-NEC male power plug. Plugs not supplied.
Order 161-0077-01 \$7.00



213

- 1 MHz at 20 mV/div
- 0.4 μs/div Sweep Rate with X10 Sweep Magnifier
- DMM and Miniscope in One Unit
- Rugged Construction
- Internal Battery

- Compact, Weighs ≈ 1.7 kg (3.7 lb)
- True RMS Voltage and Current Measurements

The 213 combines a precision 3 1/2 digit digital multimeter and a 1 MHz oscilloscope in one instrument. It is a compact (3 x 5.2 x 8.9 inches) and lightweight (only 3.7 pounds) package that will fit easily into your briefcase or tool kit.

In operation, the light-weight 213 can be hand held, rested on the equipment being tested or carried conveniently on a neck-strap. Operating controls are designed for speedy measurements and easy understanding.

Rugged construction enables the 213 to withstand hostile industrial or transportation environments.

The 213, combining both oscilloscope and DMM functions, fits many on-site service applications. As an example, the 213 is used extensively for preventive maintenance on industrial control systems.

VERTICAL DEFLECTION (VOLTAGE)

Bandwidth — Dc to 1 MHz (−3 dB point) for 20 mV/div to 100 V/div deflection factors. Dc to 400 kHz (−3 dB point) for 5 mV/div and 10 mV/div. Lower −3 dB point for ac coupling is ≈ 1 Hz.

Deflection Factor — 5 mV/div to 100 V/div (1-2-5 sequence), accurate ±3%. Uncalibrated; continuously variable between steps to at least 250 V/div.

Input R and C — 10 MΩ paralleled by 150 pF for 5 mV/div through 1 V/div and 100 pF for 2 V/div through 100 V/div.

Max Input Voltage —

| Input Condition | Max Input Voltage |
|--------------------------------------|--|
| Dc coupled, 5 mV/div to 1 V/div | 500 V (dc + peak ac) at 1 MHz or less |
| Ac coupled, 5 mV/div to 1 V/div | 800 V (dc + peak ac) 500 V peak ac component |
| Ac, Dc coupled, 2 V/div to 100 V/div | 800 V (dc + peak ac) at 1 MHz or less |

VERTICAL DEFLECTION (CURRENT)

Bandwidth — Dc to at least 400 kHz (−3 dB point) for 20 μA/div through 100 mA/div deflection factors. Dc to at least 200 kHz (−3 dB point) for 5 μA/div and 10 μA/div.

Deflection Factor — 5 μA/div to 100 mA/div (1-2-5 sequence), accurate ±3%. Uncalibrated; continuously variable between steps to at least 250 mA/div.

Max Input Current — 2 A RMS or 3 A peak for any range (fuse and diode protection).

HORIZONTAL DEFLECTION

Time Base — 2 μs/div to 500 ms/div (1-2-5 sequence), accurate ±5%.

Variable Magnifier — Increases all sweep speeds to at least X5 with a max sweep speed of 0.4 μs/div.

TRIGGER

Modes — Normal (sweep runs when triggered). Automatic (sweep free-runs in absence of trigger signal or for frequencies below 7 Hz).

Trigger Sensitivity and Coupling — Ac Internal, (auto and normal, 1 MHz) 0.5 div. Dc External, 1 MHz, 1 V.

DISPLAY

CRT — 6 x 10 div (0.52 cm/div) display. P43 Phosphor is standard.

Graticule — Internal, black line, non-illuminated.

ENVIRONMENTAL CAPABILITIES

Ambient Temperature — Operating: (battery only). −15°C to +55°C. Charging or operating from ac line: 0°C to +40°C. Nonoperating: −40°C to +60°C.

Altitude — Operating: To 25,000 ft, decrease max temperature by 1°C/1,000 ft above 15,000 ft. Nonoperating: 40,000 ft.

Vibration — Operating and nonoperating: 15 minutes along each of the 3 major axes, 0.06 cm (0.025 in) p-p displacement (4 g's at 55 Hz) 10 to 55 to 10 Hz in 1 minute cycles. Held for 3 minutes at 55 Hz.

Humidity — +40°C or less, 80% or less relative humidity.

Shock — Operating and nonoperating: 150 g's, 1/2 sine, 2 ms duration in each direction along each major axis. Total of 12 shocks.

OTHER CHARACTERISTICS

Power Sources — Internal NiCd batteries provide 3 to 5 hours operation at max trace intensity for a charging and operating temperature between +20°C and +30°C. Internal charger charges batteries when connected to an ac line with instrument turned on or off. Dc operation is automatically interrupted when battery voltage drops below 2 V to protect batteries against deep discharge. Full recharge requires ≈ 16 hours. External power source, 90 to 136 V ac (48 to 62 Hz). Option 01 allows operation from an external 180 to 250 V ac (48 to 62 Hz) or dc supply. Power consumption, 8 watts or less.

Insulation Voltage — 500 V RMS or 700 V (dc + peak ac) when operated from internal batteries with line cord and plug stored. When operated from ac, line voltage plus floating voltage not to exceed 250 V RMS or 1.4 X line + (dc + peak ac) not to exceed 350 V.

PHYSICAL CHARACTERISTICS

| Dimensions | cm | in |
|---------------------------|------|-----|
| Height | 7.6 | 3.0 |
| Width | 13.2 | 5.2 |
| Depth | 22.6 | 8.9 |
| Weights (approx) | kg | lb |
| Net (without accessories) | 1.7 | 3.7 |
| Shipping | 3.9 | 8.6 |

DMM

Provides true RMS readings of voltage and current.

DC AND AC VOLTAGE

Range — 0.1 V to 1000 V full scale in 5 ranges.

Resolution — 100 μV at 0.1 V full scale.

Accuracy in Dc Mode — For +25°C ±5°C.

Range (Full Scale) —

| | |
|----------------|--|
| 0.1 V | ±0.1% of reading ±3 counts. Temp coef is (±0.015% of reading + 0.04% of full scale) per °C. |
| 1 V | ±0.1% of reading ±1 count. Temp coef is (±0.01% of reading + 0.01% of full scale) per °C. |
| 10 V and 100 V | ±0.15% of reading ±1 count. Temp coef is (±0.015% of reading + 0.01% of full scale) per °C. |
| 1000 V | ±0.2% of reading ±1 count. Temp coef is (±0.02% of reading + 0.01% of full scale) per °C. |

Accuracy in RMS Mode — For 25°C ±5°. Temperature coefficient (±0.05% of reading + 0.1% of full scale) per °C.

| Range | Within % of reading shown ±5 counts* | | |
|----------------------|--------------------------------------|----------------|-----------------|
| | Dc | 40 Hz to 4 kHz | 4 kHz to 40 kHz |
| 0.1 V | 2.5% | 1.5% | 3.5% |
| 1 V, 10 V, and 100 V | 2% | 1% | 1% |
| 1000 V | 2% | 1% | 2% |

*Accuracy limit increases linearly for crest factor >2 up to twice indicated limit for crest factor of 5.

Input Resistance — 10 MΩ.

Input Capacitance — 150 pF on 0.1 V to 10 V ranges, 100 pF on 100 V and 1000 V ranges.

Setting Time — Dc: 1.5 sec to 0.1% of reading. RMS: 2 s to 1% of reading.

Max Input Voltage —

| Dc Coupled | |
|----------------------|----------------------|
| 0.1 V to 10 V | 100 V to 1000 V |
| 500 V (dc + peak ac) | 800 V (dc + peak ac) |
| Ac Coupled | |
| 0.1 V to 10 V | |
| 800 V (dc + peak ac) | |

DC AND AC CURRENT

Range — 0.1 mA to 1000 mA full scale in 5 ranges.

Resolution — 100 nA at 0.1 mA full scale.

Accuracy in Dc Mode — For +25°C ±5°C.

Temperature Coef — (±0.02% of reading ±0.04% of full scale) per °C. 0.1 mA ±0.5% ±3 counts. 1 mA to 1000 mA ±0.25% ±3 counts.

Accuracy in Ac Mode —

| Range | Within % of reading shown ±5 counts* | | |
|-----------------|--------------------------------------|----------------|-----------------|
| | Dc | 40 Hz to 4 kHz | 4 kHz to 40 kHz |
| 0.1 mA | 2.5% | 1.5% | 4.5% |
| 1 mA to 1000 mA | 2.5% | 1.5% | 3.5% |

*Accuracy limit increases linearly for crest factor >2 up to twice the indicated limit for crest factor of 5.

Setting Time — 1.5 s to 0.1% of reading.

Max Input Current — 2 A RMS or 3 A peak on any scale (fuse and diode protection).

RESISTANCE

Ranges — 1 kΩ to 10 MΩ full scale in 5 ranges.

Resolution — 1 Ω on 1 kΩ scale.

Accuracy — For 25°C ±5°C.

| Range | % of Reading |
|---------------|----------------|
| 1 kΩ | 0.5% ±3 counts |
| 10 kΩ to 1 MΩ | 0.5% ±1 count |
| 10 MΩ | 1% ±1 count |

Setting Time — 2 seconds ±2 counts.

READOUT

Number of Digits — 3 1/2 digits plus decimal point and sign.

Display Size — 1 cm high by 4 cm wide (5 characters).

Overrange Capability — At least 200% of full scale.

Overrange Indication — Readout displays scrambled characters.

INCLUDED ACCESSORIES

Viewing hood (016-0199-01), carrying case (016-0512-00), 2 test leads (alligator clip to banana jack) (red 012-0015-00) (black 012-0014-00), neck strap (346-0104-00), 2 power line fuses (159-0080-00), power line plug adapter (option 01 only) (161-0077-01), identification tag (334-2614-00), identification tag (000-7983-00).

ORDERING INFORMATION

213 Miniscope/DMM including batteries and probe **\$2100**

POWER OPTION

Option 01, 180 to 250 V ac (48 to 62 Hz) or dc (includes batteries and probe) **No Charge**

OPTIONAL ACCESSORIES

Alligator Clip Kit — A pair of alligator clips that allow connecting the probe and ground lead to large (up to 3/8 in) conductor. Includes: red clip (015-0229-00); yellow clip (015-0230-00); 6-32 to probe adapter (103-0051-01).

Order 015-0231-00 **\$16**

Probe-tip to BNC Panel Connector Adapter
Order 013-0084-01 **\$8.00**

Probe tip to BNC Cable Adapter,
Order 103-0096-00 **\$10.50**

Power Cable Adapter Assembly — A short length of two-wire power cord. One end has a female NEC socket fitting the 200 Series power cords; the other end is left open so that the wires can be attached to a non-NEC male power plug. Plugs not supplied.

Order 161-0077-01 **\$7.00**



212

500 kHz, 1 mV/div to 50 V/div

Internal Battery

Integral 1 MΩ Probe

Weighs ≈ 1.6 kg, (3.5 lb)

The 212 features these signal acquisition capabilities: bandwidth to 500 kHz with deflection factors from 1 mV/div to 50 V/div. It is lightweight (only 3.5 pounds) and compact (3 x 5.25 x 9.5 inches).

Built of impact-resistant plastic and fully self-contained, this miniature portable is perfect for applications in severe environments. And it permits "floating" measurements since it is double insulated and can be elevated to 700 V (dc + peak ac) above ground when operated from batteries. Although insulated, normal caution should be observed when connecting the oscilloscope probe to the test point.

The 212 features integral probes that are color matched with the vertical deflection controls to minimize measurement error. The probes have their own storage space and are part of the instrument—you can't forget and leave them behind. Clip-on 10X attenuators are available for higher voltage applications.

Trigger level and slope functions are simplified to one rotary control on the side of the unit. A convenient neckstrap is an included accessory, freeing both hands to perform other tasks.

VERTICAL DEFLECTION

Bandwidth — Dc to at least 500 kHz from 10 mV/div to 50 V/div, reducing to at least 100 kHz at 1 mV/div. Lower -3 dB point ac coupled is <2 Hz.

Deflection Factors — 1 mV/div to 50 V/div (1-2-5 sequence), accurate ±5%. Uncalibrated, continuously variable between steps to at least 125 V/div.

Display Modes — Ch 1 only, Ch 2 only, or Ch 1 and Ch 2 chopped (approx chop rate —50 kHz) from 500 ms/div to 2 ms/div of time base, alternate from 1 ms/div to 5 μs/div of time base.

Input R and C — ≈1 MΩ paralleled by ≈160 pF from 1 mV/div to 50 mV/div; and 140 pF from 100 mV/div to 50 V/div.

Max Input Voltage (1X probe only) —

| | |
|-----------------------|---|
| 1 mV/div to 50 mV/div | 600 V (dc + peak ac) ac not over 2 kHz. |
| 0.1 V/div to 50 V/div | 600 V (dc + peak ac) 600 V p-p ac 5 MHz or less |

HORIZONTAL DEFLECTION

Time Base — 5 μs/div to 500 ms/div, accurate ±5%.

Variable Magnifier — Increases each sweep rate X5 with a max sweep speed of 1 μs/div.

External Horizontal Input — (Ch 1) 1 mV/div to 50 V/div ±10%; dc to 100 kHz; X-Y phasing to 5 kHz <3°. Input characteristics same as Ch 1.

Max External Horizontal Input Voltage and Impedance — Same as for vertical inputs.

TRIGGER

Trigger Modes — Automatic or normal. Level and slope selected with a single control. Automatic operation minimizes trigger adjustment and provides a bright baseline with no input.

Trigger Sensitivity and Coupling —

| Coupling | | to 500 Hz |
|----------|---------------------------------------|-----------|
| Dc | Internal (w/composite trigger source) | 0.2 div |
| | Internal (w/ch 2 trigger source) | 0.2 div |
| | External | 1 V |

Max External Trigger Input Voltage — 8 V (dc + peak ac), 16 V (p-p ac) at 1 MHz or less.

Input Impedance — R and C, 1 MΩ paralleled by ≈30 pF.

DISPLAY

CRT — 6 x 10 div (0.52 cm/div) display. P31 Phosphor.

Graticule — Internal, black line, non-illuminated.

ENVIRONMENTAL CAPABILITIES

Ambient Temperature — Operating: (battery only), -15°C to +55°C. Charging or operating from ac line, 0°C to +40°C. Nonoperating: -40°C to +60°C.

Altitude — Operating: 25,000 ft, decrease max temperature by 1°C/1000 ft above 15,000 ft. Nonoperating: 50,000 ft.

Vibration — Operating and nonoperating: 15 minutes along each of the 3 major axes. 0.06 cm (0.025 in) p-p displacement (4 g's at 55 Hz) 10 to 55 to 10 Hz in one-minute cycles. Held for three minutes at 55 Hz.

Humidity — 5 cycles (120 hours), 95% relative humidity, referenced to MIL-E-16400F.

Shock — Operating and nonoperating: 150 g's, 1/2 sine, 2 ms duration in each direction along each major axis. Total of 12 shocks.

OTHER CHARACTERISTICS

Power Sources — Internal NiCd batteries provide ≈3 to 5 hours operation for a charging and operating temperature between +20°C and +30°C. Internal charger charges the batteries when connected to an ac line with instrument turned off. Battery operation is automatically interrupted when battery voltage drops to ≈10 V to protect batteries against deep discharge. Full recharge requires ≈16 hours. Extended charge times will not damage the batteries.

A pilot light battery-charge indicator light will extinguish when oscilloscope has about 10 min of operating time remaining in the batteries.

External Ac Source — 110 to 126 V, 58 to 62 Hz, 3 W. Can be operated at 104 to 110 V with resulting slow discharge of internal batteries.

Insulation Voltage — 500 V RMS or 700 V (dc + peak ac) when operated from internal batteries, with the line cord and plug stored. When operated from ac, line voltage plus floating voltage not to exceed 250 V RMS; or 1.4X line + (dc + peak ac) not to exceed 350 V.

PHYSICAL CHARACTERISTICS

| Dimensions | cm | in |
|---------------------------|-----------|-----------|
| Height | 7.6 | 3.0 |
| Width | 13.3 | 5.3 |
| Depth | 24.1 | 9.5 |
| Weights (approx) | kg | lb |
| Net (without accessories) | 1.6 | 3.5 |
| Shipping | 3.2 | 7.0 |

INCLUDED ACCESSORIES

Viewing hood (016-0199-01), carrying case (016-0512-00), two 4-A fuses (159-0121-00), identification tags (000-7983-00), identification tag (334-2614-00), carrying strap (346-0104-00).

ORDERING INFORMATION

212 Dual-Trace Oscilloscope, including batteries **\$1545**

POWER OPTIONS

Option 01 for 220-250 V, (48 to 52 Hz) includes batteries **No Charge**
Option 02 for 90 to 110 V, includes batteries .. **No Charge**

OPTIONAL ACCESSORIES

10X Attenuator Package — A slip-on tip to provide lower circuit loading (4.4 MΩ, ≈20 pF) and higher max input voltage 1000 V (dc + peak ac) includes: 10X attenuator (010-0378-01); pincher tip (013-0071-00); flex tip (206-0060-00); banana tip (134-0013-00); IC adapter (206-0203-00).
Order 010-0378-01 **\$45**

Alligator Clip Kit — A pair of alligator clips that allow connecting the probe (or optional 10X attenuator) and ground lead to large (up to 3/8 in) conductors. Includes: red clip (015-0229-00); yellow clip (015-0230-00); 6-32 to probe adapter (103-0051-01).
Order 015-0231-00 **\$16**

Probe-tip to BNC Panel Connector Adapter
Order 013-0084-01 **\$8.00**

Probe-tip to BNC Cable Adapter
Order 103-0096-00 **\$10.50**

Power Cable Adapter Assembly — A short length of two-wire power cord. One end has a female NEC socket fitting the 200 Series power cords; the other end is left open so that the wires can be attached to a non-NEC male power plug. Plugs not supplied.
Order 161-0077-01 **\$7.00**

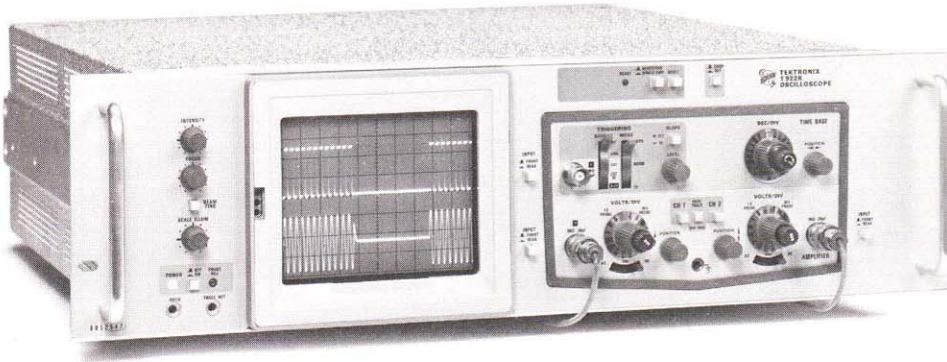

T922R

Dc to 15 MHz at 2 mV/div

Switchable Front and Rear Signal Inputs

**Only 13.3 x 48.2 x 43.2 cm, 9.1 kg
(5.25 x 19 x 17 in, 20 lb)**

Single Sweep Operation

Bright (12 kV) Display

The T922R is a rackmount multipurpose 15 MHz oscilloscope. It features: 15 MHz bandwidth at 2 mV/div vertical sensitivity, 20 ns/div maximum sweep rate with the X10 magnification control, switchable front and rear signal inputs, selectable chop and alternate sweeps, graticule illumination and rear panel outputs (gate out, sweep out and vertical signal out). The T922R fits any standard 48 cm (19 in) rack and weighs only 9.1 kg (20 lb). Option 01 adds the differential capability.

Many companies are using the T922R for their production testing applications—often as an inexpensive replacement for aging instruments which require frequent repair and calibration.

T922R CHARACTERISTICS

Seven recessed rear panel BNC connectors provide: Ch 1, Ch 2 vertical signal input, External trigger input, Z-axis input, Sweep Output, Gate Output, Vertical Output.

VERTICAL SYSTEM

Mode Selections

- Ch 1** — Displays only the Ch 1 signal.
- Ch 2** — Displays only the Ch 2 signal.
- Dual Trace** — Displays Ch 1 and Ch 2 signals simultaneously. Alternate or chopped mode is manually selectable.

Deflection Factor

Range — 2 mV/div to 10 V/div in 12 steps in a 1-2-5 sequence.

Accuracy —

| | |
|----------------|-----------|
| +20°C to +30°C | Within 3% |
| 0°C to +45°C | Within 4% |

Uncalibrated (VAR) Range — Continuously variable between settings. Extends deflection factor to at least 25 V/div.

Frequency Response — Dc to at least 15 MHz (measured at -3 dB).

Rise Time — 23 ns or less.

Chopped Mode Repetition Rate (Dual Trace) — ≈250 kHz.

Input Resistance — ≈1 MΩ.

Input Capacitance — 30 pF.

Maximum Input Voltage — Dc coupled, 400 V (dc + peak ac) 800 V p-p ac at 1 kHz or less, Ac coupled, 400 V (dc + peak ac) 800 V p-p ac at 1 kHz or less.

Delay Line — Permits viewing edge of displayed waveform.

HORIZONTAL SYSTEM

Calibrated Range — 0.5 s/div to 0.2 μs/div in 20 steps in a 1-2-5 sequence. Variable X1 to X10 magnifier extends maximum sweep rate to 20 ns/div.

Accuracy —

| | Unmagnified | Magnified |
|----------------|-------------|-----------|
| +20°C to +30°C | Within 3% | Within 5% |
| 0°C to +40°C | Within 4% | Within 6% |

Z-AXIS INPUT

Sensitivity — 5 V signal causes noticeable intensity modulation. Polarity of the voltage causing a decrease in intensity is internally selectable.

TRIGGERING

Trigger Mode

Auto — Permits normal triggering on waveforms with a repetition rate of at least 20 Hz. Sweep "free runs" in the absence of an adequate trigger signal, or with a repetition rate below 20 Hz.

Norm — Permits normal triggering. Sweep does not run in the absence of an adequate trigger signal.

TV — Provides triggering on TV field when SEC/DIV switch is set at 0.1 ms or slower. Trigger on TV line when SEC/DIV switch is set at 50 μs or faster.

Slope + Out - In — Sweep is triggered on the positive/negative-going slope of the triggering waveform.

Level — Variable control selects the amplitude point on the trigger signal when sweep triggering occurs.

Triggering Sensitivity

Auto and Norm — 0.5 div internal or 100 mV external from 2 Hz to 5 MHz, increasing to 1.5 div internal or 150 mV external at 15 MHz.

TV — Composite sync 1 div internal or 100 mV external (about 2.3 div or 230 mV of composite video).

External Trigger Input

Maximum Input — 400 V (dc + peak ac) 800 V p-p ac at 1 kHz or less.

Input Resistance — ≈1 MΩ.

Input Capacitance — 30 pF.

X-Y OPERATION

Sensitivity, Variable Magnifier — From ≈100 mV/div (X10 mag) to ≈1 V/div (X1 mag) for X; Y is adjusted by vertical control.

X-Axis Bandwidth — Dc to at least 1 MHz (measured at -3 dB).

Input Resistance — ≈1 MΩ.

Input Capacitance — 30 pF.

Phase Difference Between X and Y Axis Amplifiers — Within 5° from dc to 50 kHz.

CRT DISPLAY

Display Area — 8 x 10 cm, illuminated internal graticule.

Standard Phosphor — P31.

Beam Finder — Locates off-screen display.

Nominal Accelerating Potential — ≈12 kV.

PROBE ADJUST

Output Voltage — ≈0.5 V.

Repetition Rate — ≈1 kHz.

OUTPUTS

Sweep/Gate Out — Output Voltage is ≈5 V positive going into 1 MΩ, ≈50 mV into 50 Ω load.

Vertical Output — A composite of Ch 1 and Ch 2 with ≈0.5 V output per displayed division into a 1 MΩ load, ≈50 mV with 50 Ω load. Bandwidth is at least 1 MHz.

POWER SOURCE (AC)

Line Voltage Ranges — 100-120 V, 220-240 V line voltage and HI/LO range are accessible externally.

100-120 V Range — HI: 108 to 132 V RMS. LO: 90 to 110 V RMS.

220-240 V Range — HI: 216 to 250 V RMS. LO: 198 to 242 V RMS.

Line Frequency — 50 to 60 Hz.

Power Consumption — Watts (max) 50, amps (max) 0.35, at 120 V, 60 Hz.

Canadian Standards Association Certified.

PHYSICAL CHARACTERISTICS

| Dimensions | cm | in |
|---------------|-----------|-----------|
| Height | 13.3 | 5.25 |
| Width | 43.2 | 17.0 |
| Depth | 48.2 | 19.0 |
| Weight | kg | lb |
| Net | 9.1 | 20.0 |

ENVIRONMENTAL CAPABILITIES

Temperature

Nonoperating — -55°C to +75°C.

Operating — 0°C to +45°C.

Altitude

Nonoperating — To 15,200 meters; 50,000 ft.

Operating — To 4,500 meters; 15,000 ft max. Operating temperature decreased 1°C/304.8 meters (1,000 ft) above 1524 meters (5,000 ft).

CAMERAS

T922R interfaces to all Tektronix Cameras.

ORDERING INFORMATION

| | |
|--|-----------------|
| T922R — Oscilloscope | \$1750 |
| Option 01, Differential Input | Add \$90 |

OPTIONAL ACCESSORIES

Rackmount Hardware Kit

Order 016-0375-00 **\$75**

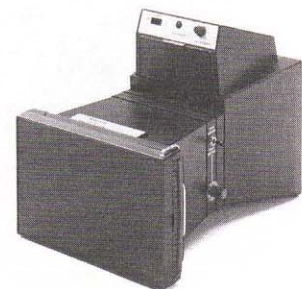

C-5C Camera

Recommended for all T900 Series Oscilloscopes, the C-5C attaches directly to the front panel without adapters and uses Polaroid pack film. A fixed f/16 lens aperture, an electric shutter with timed speeds from 0.1 to 5 seconds, plus open shutter mode, and bulb, combine to make the C-5C Option 03 which includes a built-in Xenon flash unit that flashes to illuminate the graticule when the shutter opens. The T922R uses the C-5C Option 01, without the Xenon flash. Batteries are not included for either version.

| | |
|------------------------------------|--------------|
| Order C-5C, Option 03 | \$500 |
| C-5C, Option 01 | \$480 |

An NTSC IRE TV graticule is available. Ask your local Tek Sales Engineer or Representative.

Viewing Hood

Provides for convenient viewing in high ambient light conditions.

Order Viewing Hood (016-0377-00) \$8.00

PORTABLE STORAGE OSCILLOSCOPES

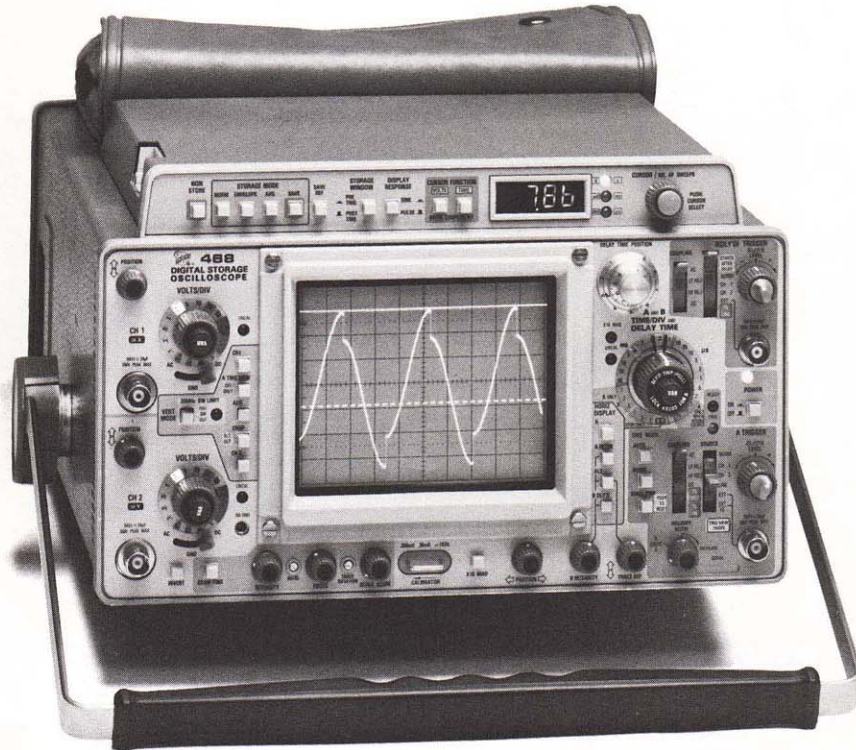

468/468R

**GPIB
 IEEE-488**

The 468 is designed to comply with IEEE Standard 488-1978, and with Tektronix Codes and Formats Standard.

10 MHz Useful Storage Bandwidth

Cursors for Time and Voltage Measurements

Envelope Mode

Signal Averaging GPIB Options

100 MHz Non-Storage Bandwidth

Advancing the state-of-the-art in digital storage oscilloscopes is the TEKTRONIX 468. This high performance portable scope is capable of accurately storing and displaying 10 MHz single shot events using a unique display interpolation system.

The 468 was designed with many features which enhance its usefulness in your applications. Cursors and a calibrated LED readout enable you to measure time or voltage differences easily and accurately.

Signal Averaging, now standard on the 468, can be used to remove random noise from a signal and improve measurement accuracy.

The ENVELOPE mode, a Tektronix exclusive, uses multiple sampling rates and digital memory to capture and record the maximum and minimum excursions of a waveform. The resulting waveform "envelope" can be used to catch glitches, view frequency drift and amplitude modulation, or detect aliasing. Unlimited storage time, expandable, repositionable stored traces; SAVE REFERENCE memory; pretrigger viewing; and correction for the trigger uncertainty inherent in digital storage make the 468 the most versatile digital storage scope available today.

In addition, the 468 features all the nonstorage performance of our 465B, the industry standard 100 MHz oscilloscope.

Options include signal averaging, a GPIB interface, a TV sync separator, and emi shielding.

DIGITIZER, MEMORY

Speed — Digitizing rates from 10 samples per second at 5 sec/div to 25 megasamples per second at 2 μ s/div and faster. Digitizing rate changes proportionate to sweep speed (50 data words per horizontal division). Chopped mode effectively halves the digitizing rate per waveform.

Resolution — 8 bit (1 part in 256) vertical resolution.

Memory Size — Up to two 512 word waveforms or four 256 word waveforms can be stored and displayed.

Interpolator — Two firmware interpolators; one optimized for sine waveforms, one optimized for pulse waveforms.

VERTICAL DEFLECTION (2 Identical Channels)

Bandwidth and Rise Time — (At all deflection factors from 50 Ω terminated source).

Storage Modes*

| Display Response | Bandwidth | Risetime |
|------------------|-----------|----------|
| Sine | 10 MHz | NA |
| Pulse | 2.5 MHz | 64 ns |

*Bandwidth measured at 5% envelope error and maximum sampling rate, using appropriate interpolator. Rise time is 1.6 times minimum sample interval. Chopped mode halves the bandwidth.

Non-Store Mode **

–15°C to +40°C +45°C to +55°C
DC to 100 MHz, 3.5 ns 85 MHz, 4.1 ns

**Measured at –3 dB. Bandwidth may be limited to \approx 20 MHz by bandwidth limit switch.

Cascaded bandwidth is at least 50 MHz when signal out is terminated in 50 Ω .

Lower –3 dB point, ac coupling 1X probe: 10 Hz or less 10X probe: 1 Hz or less.

Deflection Factor at Bandwidth —
0.5 mV/div to 5 V/div in storage modes
5 mV/div to 5 V/div in non-store
1-2-5 sequence, accurate \pm 3%

Uncalibrated, continuously variable between steps and to at least 12.5 V/div. In cascade mode sensitivity is \approx 1 mV/div. Stored images can be expanded by factor of 10 vertically.

Display Modes — Ch 1; Ch 2 ADD (normal and inverted), Trigger View (non-store only), alternate, chopped — \approx 250 kHz rate, in any combination electronically switched in non-store; in storage chop rate is 1/2 the digitizing rate.

Envelope Mode — Records waveform envelope over multiple sweeps. 5 MHz digitizing rate from 5 sec/div to 10 μ s/div; 10 MHz digitizing at 5 μ s/div; 25 MHz digitizing from 2 μ s/div and faster. Number of sweeps equals 1 to 256 plus continuous setting.

Signal Averaging — 2 to 256 sweeps can be averaged together to remove random noise.

Cmrr — Common-mode rejection ratio at least 20 dB at 20 MHz (10 MHz in storage) for common-mode signals of 6 div or less.

Automatic Scale Factor — Probe tip deflection factors for 1X or 10X coded probes are automatically indicated by two read-out lights behind the knob skirts. All LEDs are off when the channel is not displayed.

Ground Reference Display — In storage modes moving the coupling selector to ground position will locate ground and display a reference dot at left edge of CRT.

Input R and C — 1 M Ω \pm 2% paralleled by \approx 20 pF.

Max Input Voltage —

| | |
|------------|---------------------------------|
| Dc coupled | 250 V (dc + peak ac) |
| | 500 V (p-p ac at 1 kHz or less) |
| Ac coupled | 250 V (dc + peak ac) |
| | 500 V (p-p ac at 1 kHz or less) |

Delay Line — Permits viewing leading edge of displayed waveform.



R468 RACKMOUNT

HORIZONTAL DEFLECTION

Time Base A — 0.02 μ s/div to 5.0 s/div (0.5 s/div in nonstore mode) in a 1-2-5 sequence. X10 mag extends max sweep rate to 2 ns/div.

Time Base B — 0.02 μ s/div to 5.0 s/div (50 ms/div in nonstore mode) in a 1-2-5 sequence. X10 mag extends max sweep rate to 2 ns/div.

Variable Time Control — In storage modes has no effect. In non-store mode Time Base A provides continuously variable uncalibrated sweep rates between steps and to at least 1.25 s/div LED warning light indicates uncalibrated setting.

Time Base Accuracy — Full 10 cm Storage Modes 0.1%.
Non-storage Mode

| | +20°C to +30°C | -15°C to +55°C |
|-------------|----------------|----------------|
| Unmagnified | $\pm 2\%$ | $\pm 3\%$ |
| Magnified | $\pm 3\%$ | $\pm 4\%$ |

Horizontal Display Modes

Storage — A, B delayed.

Non-Storage — A, A intensified, alternate, B delayed. B ends A for increased intensity in the delayed mode. Electronic switching between intensified and delayed sweep. A sweep and B sweep may be viewed simultaneously.

CALIBRATED SWEEP DELAY

Delay Time Range — 0.2 to X10 delay time/div settings of 200 ns to 0.5 s.

Differential Time Measurement Accuracy —

| Delay Time Setting | +15°C to +35°C |
|---------------------------------------|---------------------------------|
| over one or more major dial divisions | $\pm 1\%$ |
| less than one major dial division | ± 0.01 major dial divisions |

Jitter — 1 part or less in 50,000 (0.002%) of 10X the A sweep time/div setting. 1 part in 20,000 (0.005%) when operating from 50 Hz line.

TRIGGERING A AND B

A Trigger Modes — Normal (sweep runs when triggered) automatic (sweep runs in the absence of a triggering signal and for signals below 30 Hz). Single Sweep (sweep runs one time on the first triggering event after the reset selector is pressed). LED lights indicate when sweep is triggered and when single sweep is ready.

A Trigger Holdoff — Adjustable control permits a stable presentation of repetitive complex waveforms. Non-store only.

B Trigger Modes — B runs after delay time (starts automatically at the end of the delay time) and B triggerable after delay time (runs when triggered). The B delayed sweep runs once, in each of these modes, following the A sweep delay time.

Storage Trigger Positions — Post-trigger point is at 1.25 div; Pre-trigger at 8.75 div.

Time Base A and B Trigger Sensitivity and Coupling —

| Coupling | To 25 MHz | At 100 MHz |
|--------------------|--|--------------------|
| Internal | 0.3 div deflection | 1.5 div deflection |
| Dc | | |
| External | 50 mV | 150 mV |
| External $\div 10$ | 500 mV | 1.5 V |
| Ac | Requirements increase below 60 Hz | |
| Ac Lf Reject | Requirements increase below 50 kHz | |
| Ac Hf Reject | Requirements increase below 60 Hz and above 50 kHz | |

Digital Storage Jitter — 0.5 ns or less at 100 MHz and 2 ns/div.

Digital Trigger Uncertainty — Correction circuit for the $\pm 1/2$ sample interval trigger uncertainty that is caused by asynchronous trigger/sample clock relationship.

A Trigger View — Electronically switched trigger view displays the external signal used for A sweep triggering. This provides quick verification of the signal and time comparison between a vertical signal and the trigger signal which can be displayed simultaneously. The deflection factor is ≈ 100 mV/div (1 V/div with external $\div 10$).

Nonstore mode only.

Level and Slope — Internal, permits selection of triggering at any point on the positive or negative slope of the displayed waveform. Level adjustment through at least ± 2 V in external, through at least ± 20 V in external $\div 10$.

A Sources — Norm, Ch 1, Ch 2, line, external, and external $\div 10$.

B Sources — Starts after delay, norm, Ch 1, Ch 2, and external.

External Inputs — R and C ≈ 1 M Ω paralleled by ≈ 20 pF. 250 V (dc + peak ac) max input.

X-Y OPERATION

Full-sensitivity X-Y (Ch 1 Horiz, Ch 2 Vert) — 5 mV/div to 5 V/div, accurate $\pm 4\%$. Bandwidth is dc to at least 4 MHz. Phase difference between amplifiers is 3° or less from dc to 50 kHz.

Non-store mode only.

DISPLAY

CRT — 8 x 10 cm display. Horizontal and vertical centerlines further marked in 0.2 cm increments. P31 Phosphor standard; P11 optional. 18 kV accelerating potential.

Graticule — Internal, nonparallax; variable edge lighting; markings for measurement of rise time.

Beam Finder — Compresses trace to within graticule area for ease in determining the location of an offscreen signal. A pre-set intensity level provides a constant brightness.

Z-Axis Input — Dc coupled, positive-going signal decreases intensity; 5 V p-p signal causes noticeable modulation at normal intensity; dc to 50 MHz. Non-store mode only.

ENVIRONMENTAL CAPABILITIES

Ambient Temperature — Operating: -15°C to $+55^\circ\text{C}$. Non-operating: -55°C to $+75^\circ\text{C}$. Filtered forced air ventilation is provided.

Altitude — Operating: to 15,000 ft: max allowable ambient temperature decreased by $1^\circ\text{C}/1000$ ft. from 5000 to 15,000 ft. Nonoperating to 50,000 ft.

Vibration — Operating: 15 minutes along each of the three axes, 0.06 cm (0.025 in) p-p displacement (4 g's at 55 Hz) 10 to 55 to 10 Hz in 1 minute cycles.

Humidity — Operating and nonoperating 5 cycles (120 hours) to 95% relative humidity as specified in MIL-T-28800B (par 3.9.2.2).

Shock — Operating and nonoperating: 30 g's 1/2 sine, 11 ms duration, 3 shocks per axis in each direction for a total of 18 shocks.

OTHER CHARACTERISTICS

Amplitude Calibrator

| | | |
|----------------|--------------|----------------------|
| Output Voltage | 0.3 V | 1% 0°C to +40°C |
| Output Current | 30 mA | 2% +20°C to +30°C |
| Frequency | Approx 1 kHz | |

Vertical Signal Output — Ch 1 vertical signal is dc to at least 50 MHz (-3 dB), and ≈ 25 mv/div terminated into 50 Ω , and ≈ 50 mV/div terminated into 1 M Ω .

Gate Outputs — Positive gates from both time bases (≈ 5 V).

Power Requirements — Quick change line voltage selector provides four ranges to cover 90-132 V and 198-250 V. 48 to 440 Hz, 150 watts max at 115 V and 60 Hz.

PHYSICAL CHARACTERISTICS

| Dimensions | cm | in |
|--|------|------|
| Height | 15.7 | 6.2 |
| Width (with handle) | 32.8 | 13.1 |
| Depth (with panel cover) | 55.0 | 21.7 |
| Depth (handle extended) | 60.0 | 23.8 |
| Weights (approx) | kg | lb |
| Net (without panel cover) | 12.7 | 28.0 |
| Net (with panel cover and accessories) | 13.9 | 30.5 |
| Shipping | 19.1 | 42.2 |

INCLUDED ACCESSORIES

Two P6105 10X probes (010-6105-03), blue accessory pouch (016-0594-00), clear pouch (016-0537-00), blue CRT light filter (337-1674-00), clear CRT light filter (337-1674-01), ground wire (134-0016-01), two 1 1/2-amp fuses (159-0016-00), one 3/4-amp fuse (159-0042-00).

ORDERING INFORMATION

468 Oscilloscope \$6270
R468 Rackmount Oscilloscope \$6520

INSTRUMENT OPTIONS

Option 02 GPIB Interface — Addressable talker; follows Tektronix codes and formats **Add \$820**
Option 04 Emc Environmental **Add \$140**
Option 05 TV Sync Separator (Provides triggering on TV field and line) **Add \$260**
Option 78 P11 Phosphor **Add \$35**
Modification kits, for field conversion of existing 468s to Option 02, are available. These are typically more expensive than when the option is ordered with the instrument. Contact your Tektronix Sales Engineer, Distributor, or Representative for information.

INTERNATIONAL POWER CORD AND PLUG OPTIONS

Option A1 Universal Euro 220 V/16 A **No Charge**
Option A2 UK 240 V/13 A **No Charge**
Option A3 Australian 240 V/10 A **No Charge**
Option A4 North American 240 V/15A **No Charge**

OPTIONAL ACCESSORIES

Optional Service ROM

This provides service and signature analysis routines for verification and troubleshooting the digital portion of the instrument. Recommended to be used with a TEKTRONIX 308 Data Analyzer. **Order 067-0989-00** **\$85**

Probes —

| Probe Type | Attenuation | Input Impedance | Bandwidth* |
|----------------------------------|--------------------------|--|--------------------------|
| P6063B 6 ft. | 1X | 1 M Ω 105 pF | 6 MHz |
| | Switchable | 10 M Ω 14 pF | 90 MHz |
| P6202 FET Probe 2 Meter | 10X | 10 M Ω 2 pF | 100 MHz |
| | 100X Head Ac Head | 10 M Ω 2 pF 10 M Ω 4 pF | 100 MHz 100 MHz |
| Current Probe | Calibration | Insertion Impedance | |
| P6022 | 1 mA/mV | 0.03 Ω at 1 MHz | 85 MHz |
| 5 ft. | 10 mA/mV (Selectable) | Increasing to 0.2 Ω at 120 MHz | |

*Non-store modes — Bandwidths are measured at the upper -3 dB and apply only to the cable length shown. Generally, shorter cable lengths increase bandwidth, longer ones decrease bandwidth.

Folding Polarized Viewing Hood —

Order 016-0180-00 **\$40**

Collapsible Viewing Hood — Binocular

Order 016-0566-00 **\$15**

Protective Cover — Waterproof, blue vinyl

Order 016-0365-00 **\$21**

Mesh Filter — Improves contrast and emc filtering

Order 378-0726-01 **\$45**

SCOPE-MOBILE® Cart — Occupies <18 in aisle space, has storage area in base

Order 200C **\$265**

1105 Battery Power Supply **\$1240**

Rack Adapter 016-0675-00 **\$300**

RECOMMENDED CAMERA

C-30BP Option 01 General Purpose Compact Camera Includes 016-0301-00 mounting adapter/corrector lens.

Order C-30BP Option 01 **\$1285**

For further information see Camera section.

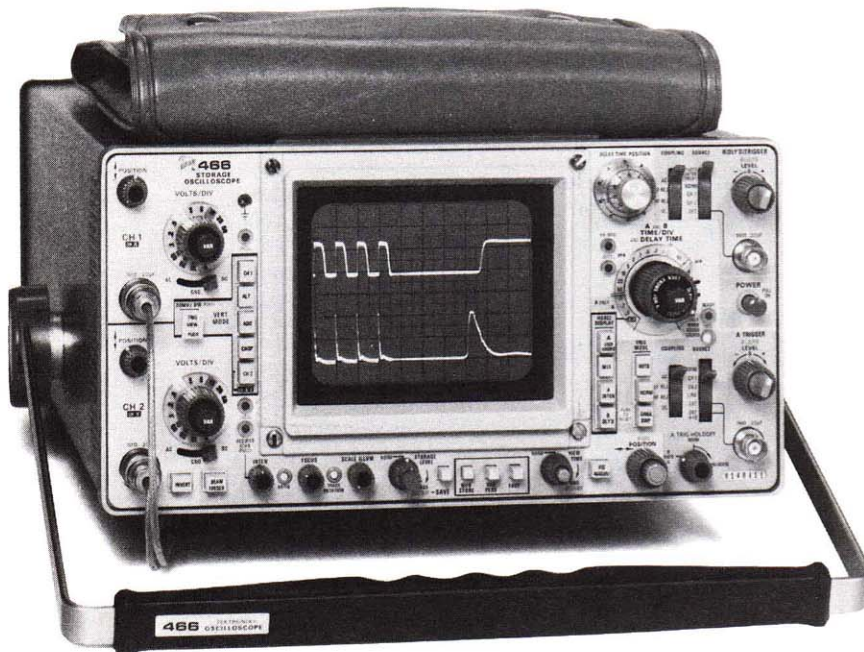

466/464

100 MHz at 5 mV/div

5 ns/div Sweep Rate with X10 Sweep Magnifier

Variable Persistence and Fast Mesh Transfer Storage Modes

3000 div/ μ s Stored Writing Speed (466)

Battery Operation (optional)

Third Channel Trigger View now available on 466 and 464

Weighs \approx 11.8 kg, (26 lb)

The 466 and 464 Portable Storage Oscilloscopes are both designed to display nonrepetitive or slow moving signals. And with the exception of increased stored writing speed on the 466, both instruments offer similar performance.

Operating in a reduced scan mode, the stored writing speed of the 466 is 3000 div/ μ s (1350 cm/ μ s). The lower cost 464 doesn't offer a reduced scan mode and stores at 110 div/ μ s. Both instruments feature two modes of storage — variable persistence and fast transfer.

The bright 8 x 10 div CRT on both instruments comprises 0.90 cm/divisions. In the 466, reduced scan graticule is superimposed over the center of the main graticule, measuring 8 x 10 divisions with 0.45 cm/division. All graticules are etched onto the inner face of the CRT to eliminate parallax problems. A third channel trigger view option is now available for the 466 and 464. This option allows the simultaneous display of channels 1 and 2 with the external A trigger.

TEKTRONIX P6062B Probes provide operator convenience of 1X or 10X input attenuation at the probe tip. The correct deflection factor is automatically indicated on the 464 or 466 front panel when the probe attenuation factor is switched.

Light weight plus the ability to use optional, external dc power makes both the 466 and 464 sufficiently portable for virtually all field measurement applications. The snap-on 1106 Battery Pack is also useful in isolating these oscilloscopes from noisy or intermittent power sources.

CHARACTERISTICS

All characteristics apply to both the 466 and 464, except where indicated.

VERTICAL DEFLECTION (2 Identical Channels)

Bandwidth* and Rise Time — at all deflection factors from 50 Ω terminated source.

| | |
|------------------------------|------------------------------|
| -15°C to +40°C | +40°C to +55°C |
| Dc to 100 MHz, \leq 3.5 ns | Dc to 85 MHz, \leq 4.15 ns |

*Measured at -3dB down. Bandwidth may be limited to \approx 20 MHz by bandwidth limit switch. Lower -3 dB point, ac coupling 1X probe; 10 Hz or less. 10X probe; 1 Hz or less.

Deflection Factor — 5 mV/div to 5 V/div (1-2-5 sequence); accurate \pm 3%. Uncalibrated, continuously variable between steps and to \approx 12.5 V/div. In cascade mode sensitivity is \approx 1 mV/div. Cascaded bandwidth is at least 50 MHz when signal out is terminated in 50 Ω .

Display Modes — Ch 1, Ch 2 (normal or inverted), alternate, chopped (\approx 250 kHz), added, X-Y.

CMRR — Common-mode rejection ratio at least 20 dB at 20 MHz for common-mode signals of 6 div or less.

Automatic Scale Factor — Probe tip deflection factors for 1X or 10X coded probes are automatically indicated by two readout lights behind the knob skirts. All lights are off when the channel is not displayed. Ground reference display selectable at probe (when dc coupled).

Input R and C — 1 M Ω \pm 2% paralled by \approx 20 pF.

Max Input Voltage —

| | |
|------------|---|
| Dc coupled | 250 V (dc + peak ac) 500 V (p-p ac at 1 kHz or less) |
| Ac coupled | 500 V (dc + peak ac) 500 V (p-p ac at 1 kHz or less) |

Delay Line — Permits viewing leading edge of displayed waveform.

HORIZONTAL DEFLECTION

Time Base A — 0.05 μ s/div to 0.5 s/div (1-2-5 sequence). X10 mag extends sweep rate to 5 ns/div.

Time Base B — 0.05 μ s/div to 50 ms/div (1-2-5 sequence). X10 mag extends sweep rate to 5 ns/div.

Variable Time Control — Time Base A — Provides continuously variable uncalibrated sweep rates between steps and to at least 1.25 s/div. Warning light indicates uncalibrated setting.

Time Base A and B Accuracy — Full 10 div.

| | | |
|-------------|----------------|----------------|
| | +20°C to +30°C | -15°C to +55°C |
| Unmagnified | \pm 2% | \pm 3% |
| Magnified | \pm 3% | \pm 4% |

Horizontal Display Modes — A, mixed sweep, A intensified, B delayed. B ends A for increased intensity in the delayed mode.

Calibrated Mixed Sweep — Displays A sweep for period determined by DELAY-TIME POSITION control, then displays B sweep for remainder of horizontal sweep.

CALIBRATED SWEEP DELAY

Delay Time Range — 0.2 to X10 delay time/div settings of 200 ns to 0.5 s (minimum delay time is 200 ns).

Differential Time Measurement Accuracy —

| | | |
|---------------------------------|---------------------------|----------------------------|
| Delay Time Setting | +15°C to +35°C | -15°C to +55°C |
| over one or more major dial div | \pm 1% | \pm 2.5% |
| less than one major dial div | \pm 0.01 major dial div | \pm 0.025 major dial div |

Jitter — One part or less in 50,000 (0.002%) of X10 the A sweep time/div setting.

TRIGGERING A and B

A Trigger Modes — Normal (sweep runs when triggered), automatic (sweep free-runs in the absence of a triggering signal and for signals below 30 Hz). Single Sweep (sweep runs one time on the first triggering event after the reset selector is pressed). Lights indicate when sweep is triggered and when single sweep is ready.

A Trigger Holdoff — Adjustable control permits a stable presentation of repetitive complex waveforms. At least 10:1 variation.

B Trigger Modes — B starts after delay time (starts automatically at the end of the delay time). B triggerable after delay time (runs when triggered). The B (delayed) sweep runs once, in each of these modes, following the A sweep delay time.

Time Base A and B Trigger Sensitivity and Coupling —

| Coupling | To 25 MHz | At 100 MHz | |
|----------|---------------|--|------------------------------------|
| Dc | Int | 0.3 div deflection | 1.5 div deflection |
| | Ext | 50 mV | 150 mV |
| | Ext \div 10 | 500 mV | 1.5 V |
| Ac | Ac Lf Reject | Requirements increase below 60 Hz | Requirements increase below 50 kHz |
| | Ac Hf Reject | Requirements increase below 30 Hz and above 50 kHz | |

Jitter — 0.5 ns or less at 100 MHz and 5 ns/div (X10 mag).

A Trigger View — A spring-loaded pushbutton overrides other vertical controls and displays the external signal used for A sweep triggering. This provides quick verification of the signal and time comparison between a vertical signal and the trigger signal. The deflection factor is ≈ 50 mV/div (0.5 V/div with external $\div 10$ source).

Level and Slope — Internal, permits selection of triggering at any point on the positive or negative slope of the displayed waveform. Level adjustment through at least ± 2 V in external, through at least ± 20 V in external $\div 10$.

A Sources — Norm, Ch 1, Ch 2 line, external and external $\div 10$.

B Sources — Starts after delay, norm, Ch 1, Ch 2, and external.

External Inputs — R and C ≈ 1 M Ω paralleled by ≈ 20 pF. 250 V (dc + peak ac) max input.

Third Channel Trigger View Specifications (Option 10) —

Deflection Factor (Dc trigger coupling only)

EXT 100 mV/div $\pm 5\%$

EXT $\div 10$ 1 V/div $\pm 5\%$

Delay difference (to Ch 1 or Ch 2) 3.5 ns ± 1 ns

Trigger point is approximately center screen.

Risetime ≤ 5 ns.

Aberration $< 10\%$ p-p.

X-Y OPERATION

Full Sensitivity X-Y (Ch 1 Horiz. Ch 2 Vert) — 5 mV/div to 5 V/div, accurate $\pm 4\%$. Bandwidth is dc to at least 4 MHz. Phase difference between amplifiers is 3° or less from dc to 50 kHz.

DISPLAY

CRT — 8 x 10 div display, each div is 0.9 cm (normal); 0.45 cm/div reduced scan (466 only). 8.5 kV accelerating potential, normal-mode, 10 kV reduced scan (466 only). P31 Phosphor.

Graticule — Internal, nonparallax; variable edge lighting; markings for measurement of rise time.

Beam Finder — Compresses trace to within graticule area for ease in determining the location of an off-screen signal. A pre-set intensity level provides a constant brightness.

Z-Axis Input — Dc coupled, positive-going signal decreases intensity; 5 V p-p signal causes noticeable modulation at normal intensity; dc to 50 MHz.

STORED WRITING SPEEDS

| | 466 | 464 | Storage* View Time |
|---|--------------------|-----------------------------------|--------------------|
| Full Scan (Center 6 x 8 div; 0.9 cm/div) | | | |
| FAST | 150 div/ μ s | 110 div/ μ s | >15s |
| VARIABLE PERSISTANCE | 0.5 div/ μ s | 0.5 div/ μ s | >15s |
| Reduced Scan (Center 8 x 10 div; 0.45 cm/div) | | Reduced Scan not available on 464 | |
| FAST | 3,000 div/ μ s | | >15s |
| VARIABLE PERSISTANCE | 3 div/ μ s | | >15s |

*These times are at full-stored display intensity; they can be extended at least 25 times using reduced intensity in SAVE Display Mode.

ENVIRONMENTAL CAPABILITIES

Ambient Temperature — Operating: -15°C to $+55^{\circ}\text{C}$. Non-operating: -55°C to $+75^{\circ}\text{C}$. Forced air ventilation is provided.

Altitude — Operating: to 15,000 ft; max allowable ambient temperature decreased by $1^{\circ}\text{C}/1000$ ft from 5000 to 15,000 ft. Nonoperating to 50,000 ft.

Vibration — Operating: 15 minutes along each of the three axes, 0.06 cm (0.025 in) p-p displacement (4 g's at 55 Hz) to 55 to 10 Hz in 1 minute cycles.

Humidity — Operating and nonoperating: 5 cycles (120 hours) to 95% relative humidity referenced to MIL-E-16400F (par 4.5.9 through 4.5.9.5.1, class 4).

Shock — Operating and nonoperating: 30 g's, 1/2 sine, 11 ms duration, 2 shocks per axis in each direction for a total of 12 shocks.

OTHER CHARACTERISTICS

Amplitude Calibrator —

| | | |
|----------------|--------------|--|
| Output Voltage | 0.3 V | 1% 0°C to $+40^{\circ}\text{C}$ |
| Output Current | 30 mA | 2% $+20^{\circ}\text{C}$ to $+30^{\circ}\text{C}$ |
| Frequency | Approx 1 kHz | |

Vertical Signal Output — Ch 1 vertical signal is dc to at least 50 MHz and ≈ 25 mV/div terminated into 50 Ω , and ≈ 50 mV/div terminated into 1 M Ω .

Gate Outputs — Positive gates from both time bases (≈ 5 V).

Power Requirements — Quick-change line voltage selector provides six ranges: 110 V, 115 V, 120 V, 220 V, 230 V, and 240 V, each $\pm 10\%$. 48 to 440 Hz, 100 W max at 115 V and 60 Hz. Operation from 12 to 24 V dc is available with Option 07.

PHYSICAL CHARACTERISTICS

| Dimensions | in | cm |
|--|------|------|
| Height (w/o pouch) | 6.2 | 15.9 |
| Width (with handle) | 13.1 | 33.0 |
| Depth (with panel cover) | 21.7 | 55.0 |
| Depth (handle extended) | 23.8 | 59.7 |
| Weights (approx) | lb | kg |
| Net (without panel cover or accessories) | 26.0 | 11.8 |
| Net (with panel cover and accessories) | 29.8 | 13.5 |
| Shipping | 41.5 | 18.8 |

INCLUDED ACCESSORIES

Two P6062B Probes (010-6062-13), blue accessory pouch (016-0535-02), clear pouch (016-0537-00), CRT light filter (337-1674-01), two 1 1/2-amp fuses (159-0016-00), one 3/4-amp fuse (159-0042-00), adapter, ground wire (134-0016-01), viewing hood (016-0592-00).

ORDERING INFORMATION

- 466 Storage Oscilloscope \$6385
- 466 DM 44 Storage Oscilloscope/DMM
- DM 44 Multimeter info on p.233 \$6890
- 464 Storage Oscilloscope \$5165
- 464 DM 44 Storage Oscilloscope/DMM
- DM 44 Multimeter info on p.233 \$5670

INSTRUMENT OPTIONS

- Option 01 Delete DM 44 Temperature Probe (466 DM 44, 464 DM 44 only) Sub \$80
- Option 04 Emc Modification Add \$140
- Option 05 TV Sync Separator (Provides triggering on TV field) Add \$260
- Option 07 Ext Dc Operation (Option 07 cannot be ordered with DM 44) Add \$220
- Option 10 Third Channel Trigger View Add \$110 (Option 10 cannot be ordered with Option 05)
- Option 1Y 100/200 VAC Operation No Charge

INTERNATIONAL POWER CORDS AND PLUG OPTIONS

- Option A1 Universal Euro 220 V/16A No Charge
- Option A2 UK 240 V/13A No Charge
- Option A3 Australian 240 V/10A No Charge
- Option A4 North American 240 V/15A No Charge

Modification kits for field conversion of existing 466s and 464s to Option 07 or DM 44 equipped scopes are available. These are typically more expensive than when the option is ordered with the instrument. Contact your Tektronix Sales Engineer, Distributor, or Representative for information.

OPTIONAL ACCESSORIES

Probes —

| Probe Type | Attenuation | Input Impedance | Bandwidth* with 464/466 |
|-------------------------------|-------------------------------------|---|-------------------------|
| P6063B 6 ft | 1X Switchable 10X | 1 M Ω 105 pF 10 M Ω 14 pF | 6 MHz 90 MHz |
| P6202 FET Probe 2 Meter | 10X 100X Head Ac Head | 10 M Ω 2 pF 10 M Ω 2 pF 10 M Ω 4 pF | 100 MHz |
| Current Probe | Calibration | Insertion Impedance | Bandwidth with 464/466 |
| P6022 | 1 mA/mV 10 mA/mV (Selectable) | 0.03 Ω @ 1 MHz Increasing to 0.2 Ω @ 120 MHz | 85 MHz |

*Bandwidths are measured at the upper -3 dB point, and apply only to the cable length shown. Generally, shorter cable lengths increase bandwidth, longer ones decrease bandwidth.

OPTIONAL ACCESSORIES



- 1106 Battery Pack (used with Option 07) \$905
- 1105 Battery Power Supply \$1240
- Mesh Filter — Improves display contrast in high ambient light. Order 378-0726-01 \$45
- Protective Cover — Waterproof vinyl. For 464/466 Order 016-0365-00 \$21
- Folding Viewing Hood — Order 016-0592-00 \$12
- Folding Binocular Hood — Order 016-0566-00 \$15
- Polarized Collapsible Viewing Hood — Order 016-0180-00 \$40
- SCOPE-MOBILE® Cart — Occupies < 18 inches aisle space, has storage area in base. Order 200 C \$265
- Rack Adapter — Order 016-0676-00 \$250 (Not for DM 44)

RECOMMENDED CAMERA

- C-30BP Option 01 General Purpose Camera — Includes 016-0301-01 mounting adapter/corrector lens. Order C-30BP Option 01 \$1285
 - Camera Adapter — Mounts C-30B Series Camera to 464/466 Oscilloscopes. Order 016-0301-01 \$105
- For further information see Camera section.

TEK 25 MHz DUAL TRACE STORAGE OSCILLOSCOPE



434

25 MHz at 10 mV/div

20 ns/div Sweep Rate with X50 Sweep Magnifier

Weights \approx 9.4 kg (20.8 lb.)

A bistable, split-screen storage oscilloscope with a 25 MHz bandwidth, the compact 434 fills many needs.

The split screen provides: full-screen storage, or upper or lower screen storage, with the other half conventional.

Tektronix 434s are used for maintaining display boards, video monitors, automatic baggage handling systems, X-ray systems, and air-conditioning and heating systems.

VERTICAL DEFLECTION (2 Identical Channels)

Bandwidth and Rise Time — (from 50 Ω terminated source, with or without 10X probe) Dc to at least 25 MHz at 3 dB down*, 14 ns from 10 mV/div to 10 V/div, decreasing to 15 MHz, 22 ns at 1 mV/div. Low frequency 3 dB down point with ac coupling is 14 Hz or less (<1 Hz with 10X probe).

Deflection Factor — 1 mV/div to 10 V/div, accurate \pm 3%. Uncalibrated, continuously variable between steps and to \approx 25 V/div.

Display Modes — Ch 1 only, Ch 2 only (normal or inverted), alternate, chopped (\approx 100 kHz), added.

CMRR — Common-mode rejection ratio at least 20 dB at 10 MHz for common-mode signals of 6 div or less.

Automatic Scale Factor — Probe tip deflection factors for 1X or 10X coded probes are indicated by lights besides the knob skirts. Ground reference display selectable at probe (when dc coupled).

Input R and C — 1 M Ω \pm 2% paralleled by \approx 24 pF.

Max Input Voltage — Dc coupled: 250 V (dc + peak ac); ac coupled: 500 V (dc + peak ac). In either mode the max ac is 500 V p-p at 1 kHz or less.

Delay Line — Permits viewing of leading edge of displayed waveform.

HORIZONTAL DEFLECTION

Time Base — 0.2 μ s/div to 5 s/div (1-2-5 sequence). X50 mag extends fastest sweep rate to 20 ns/div.

Variable Time Control — Uncalibrated, continuously variable between steps and to 12.5 s/div.

Time Base Accuracy, Full 10 div —

| | +20°C to +30°C | -15°C to +55°C |
|-------------|----------------|----------------|
| Unmagnified | \pm 3% | \pm 4% |
| Magnified | \pm 4% | \pm 5% |

*Bandwidth derated to 22 MHz above +30°C.

External Horizontal Input — Deflection factor is \approx 0.5 V/div. Input resistance is \approx 50 k Ω .

TRIGGER

Modes — Auto trigger (sweep free-runs in absence of triggering signal, normal trigger, single sweep.

Trigger Sensitivity and Coupling —

| Coupling | To 5 MHz | | At 25 MHz | |
|--------------|------------------------------------|----------|------------------|----------|
| | Internal | External | Internal | External |
| Dc | 0.3 div deflection | 50 mV | 1 div deflection | 125 mV |
| Ac | Requirements increase below 20 Hz | | | |
| Ac Lf Reject | Requirements increase below 50 kHz | | | |
| Ac Hf Reject | Requirements increase above 50 kHz | | | |

Sources — Ch 1 only, composite line, external and external \pm 10. External trigger level range is at least +2 V to -2 V or +20 V to -20 V.

External Inputs — Input R \approx 1 M Ω paralleled by 100 pF \pm 1 or 70 pF \pm 10. 250 V (dc + peak ac).

DISPLAY

CRT — 8 x 10 div (1 div = 0.975 cm) horizontal and vertical divisions further marked in 0.2 div increments. P1 Phosphor. 4 kV accelerating potential.

Graticule — Internal, non parallax; non-illuminated.

Beam Finder — Compresses trace to within graticule area for ease in locating an off-screen signal.

Z-Axis Input — Dc coupled, positive going signal decreases intensity. 5 V p-p signal causes noticeable modulation; dc to 20 MHz usable frequency range.

STORAGE FEATURES

Display Modes — Split-screen with storage on upper or lower half of screen with conventional display on other half. Storage on entire screen or conventional display. Independent operation of halves.

Stored Writing Speed (Center 8 div) — Normal, 100 div/ms. Enhanced, increases single-sweep storage writing speed to at least 400 div/ms. (Option 01, 500 div/ms, normal; to 5000 div/ms, enhanced).

Erase Time — 300 ms or less.

Locate — Beam can be positioned left of the graticule area to determine vertical position of next sweep without disturbing stored display.

ENVIRONMENTAL CAPABILITIES

Ambient Temperature — Operating: -15°C to +55°C. Non-operating: -55°C to +75°C.

Altitude — Operating: to 15,000 ft; max allowable ambient temperature decreased by 1°C/1000 ft from 5000 to 15,000 ft. Nonoperating: to 50,000 ft.

Vibration — Operating: 15 minutes along each of the three axes, 0.06 cm (0.025 in) p-p displacement (4 g's at 55 Hz) 10 to 55 to 10 Hz in 1 minute cycles.

Humidity — Operating and nonoperating: 5 cycles (120 hours) to 95% relative humidity referenced to MIL-E-16400F (par 4.5.9.1, class 4).

Shock — Operating and nonoperating: 30 g's, 1/2 sine, 11 ms duration, 2 shocks per axis in each direction for a total of 12 shocks.

OTHER CHARACTERISTICS

Amplitude Calibrator — 0.6 V \pm 1.0%, 1 kHz \pm 1.0% (+20°C to +30°C). Output resistance is 575 Ω .

Power Requirements — Operates on all voltages from 90 V to 136 V and 180 V to 272 V, 48 to 440 Hz, 60 W max. Also operates from 220 V dc to 350 V dc.

PHYSICAL CHARACTERISTICS

| Dimensions | Cabinet | | Rackmount | |
|---------------------|---------|------|-----------|------|
| | cm | in | cm | in |
| Height (w/o pouch) | 14.2 | 5.6 | 13.3 | 5.3 |
| Width (with handle) | 33.0 | 13.0 | 48.3 | 19.0 |
| Depth | 47.5 | 18.7 | 45.7 | 18.0 |
| Weights (approx) | kg | lb | kg | lb |
| Net | 9.4 | 20.8 | 10.5 | 23.1 |
| Shipping | 13.6 | 30.0 | 22.2 | 49.0 |

INCLUDED ACCESSORIES

Two P6105 Probes (010-6105-03), accessory pouch (016-0165-00). Rack models also include mounting hardware and slide out assemblies, but not pouch.

ORDERING INFORMATION

| | |
|---|-----------|
| 434 Storage Oscilloscope | \$4400 |
| R434 Storage Oscilloscope Rackmount Model | \$4570 |
| Option 01 Increased Writing Speed | Add \$200 |

OPTIONAL ACCESSORIES

| Probe Type | Attenuation | Input Impedance | Bandwidth* with 434 |
|----------------|-------------------------------------|---|---------------------|
| P6062A 6 ft | Switch-able | 1 M Ω 5 pF | 6.7 MHz |
| | 10X | 10 M Ω 14 pF | 25 MHz |
| Current Probe | Calibration | Insertion Impedance | Bandwidth with 434 |
| P6022 | 1 mA/mV 10 mA/mV (Selectable) | 0.03 Ω @ 1 MHz increasing to 0.2 Ω @ 120 MHz | 25 MHz |

*Bandwidths are measured at the upper -3 dB, and apply only to the cable length shown. Generally, shorter cable lengths increase bandwidth.

| | |
|---|--------|
| 1105 Battery Power Supply — | |
| Order 1105 Battery Power Supply | \$1240 |
| Mesh Filter — Improves contrast and emc filtering. | |
| Order 378-0682-00 | \$33 |
| Portable to Rackmount Assembly — Includes hardware for standard 434 in 19 inch rack mounting. | |
| Order 016-0272-00 | \$200 |
| Folding Polarized Viewing Hood — | |
| Order 016-0180-00 | \$40 |
| SCOPE-MOBILE* Cart — Occupies <18 inches aisle space, has storage area in base. | |
| Order 200C | \$265 |

RECOMMENDED CAMERA

C-30BP Option 01 General Purpose Camera — Includes 016-0301-00 mounting adapter/corrector lens.
Order C-30BP Option 01

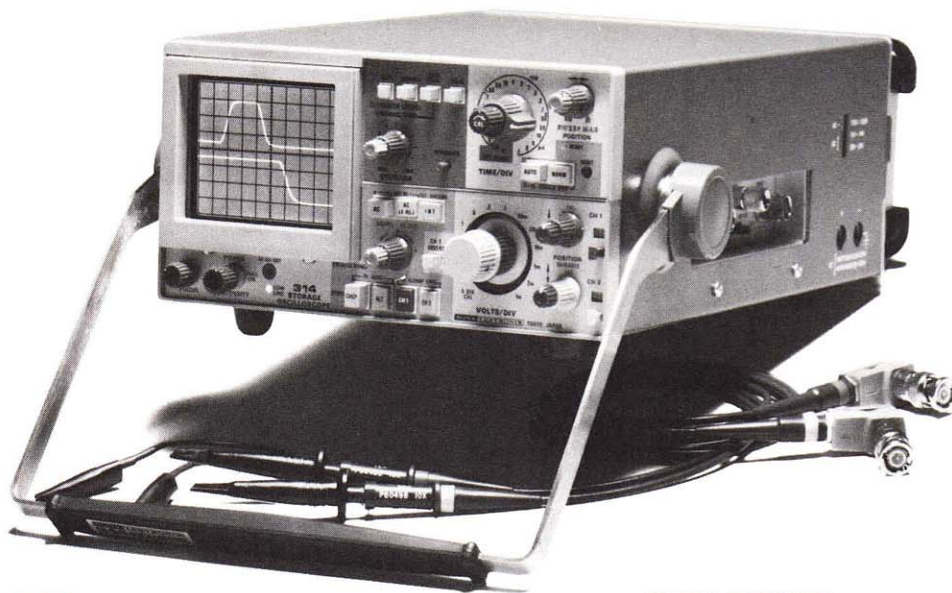

314

10 MHz at 1 mV/div

100 ns/div Sweep Rate with X10 Sweep Magnifier

Stored Viewing Time to 4 Hours

Integrate Mode for Intensifying Fast Rise Time, Low Repetition Rate Signals

Operates from Ac Line, 12 V Dc, or 24 V Dc

Small Size, Weights ≈ 4.7 kg, (10.5 lb)

The 10.5 pound, bistable storage 314 provides 1 mV/div sensitivity at 10 MHz, with a 4 hour viewing time. With long-term storage, you can use the 314 to monitor signal lines where undesired transients are suspected.

For fast rise time, low repetition rate signals, an integrate mode increases the intensity of the stored trace.

Compact size and operation from ac, dc or external dc source mean that the 314 will easily go wherever you need a storage oscilloscope.

Combined function controls, color coding, and functional front-panel layout make the 314 easy to use. Probes mount on the side, permitting an uncrowded front panel and large CRT.

The 1 mV/div sensitivity is particularly useful for measurement of transducer signals such as those from magnetic recording heads. An autoerase mode, with variable erase period from 1 to 5 seconds, enhances the ability of the 314 to make measurements on slowly changing analog signals such as those from a pressure transducer. Other applications for the 314 occur in industrial control systems, biophysical instrumentation, communication terminals, POS terminals, computer peripherals, and communication systems.

VERTICAL DEFLECTION

Bandwidth and Rise Time — Dc to at least 10 MHz. Rise time, 36 ns or less for a 4 div step input. For ac coupling, the lower 3 dB point is 10 Hz or less.

Deflection Factor — 1 mV/div to 10 V/div (1-2-5 sequence), accurate ±3%. Continuously variable between steps and to at least 25 V/div (uncalibrated).

Display Modes — Ch 1, Ch 2 (normal or inverted), chopped, alternate, added, and X-Y.

Input R and C — 1 MΩ paralleled by ≈47 pF.

Max Input Voltage — Ac or dc coupled, 300 V (dc + peak ac).

Delay Line — Permits viewing leading edge of displayed waveform.

HORIZONTAL DEFLECTION

Time Base — 1 μs/div to 5 s/div. X10 mag extends sweep rate to 100 ns/div.

Variable Time Control — Uncalibrated, continuously variable between steps and to at least 12.5 s/div.

Time Base Accuracy, center 8 div

| Unmagnified | | |
|---------------------------|--|-----|
| 1 μs/div to 0.2 s/div | | ±3% |
| 0.5 s/div to 5 s/div | | ±4% |
| Magnified | | |
| 50 ms/div to 0.5 s/div | | ±5% |
| 0.5 μs/div to 20 ms/div | | ±4% |
| 0.1 μs/div and 0.2 μs/div | | ±5% |

TRIGGER

Modes — Normal (sweep generator requires a trigger to generate a sweep). Automatic (minimizes trigger adjustment). Sweep generator free-runs in the absence of a trigger. Single sweep (one sweep is initiated by the first trigger after a reset).

Trigger Sources — Internal: Ch 1, Ch 2 or composite, external.

Trigger Sensitivity and Coupling

| Coupling | | To 1 MHz | At 10 MHz |
|--------------|------------------------------------|--------------------|------------------|
| Dc | Internal | 0.3 div deflection | 1 div deflection |
| | External | 150 mV | 500 mV |
| Ac | requirements increase below 30 Hz | | |
| Ac Lf Reject | requirements increase below 50 kHz | | |

X-Y OPERATION

Input — X-axis input is via the external horizontal input connection. Both Ch 1 and Ch 2 provide vertical inputs. Using chopped mode, two simultaneous X-Y displays can be obtained.

X-Axis Deflection Factors — Continuously variable from 20 mV/div to 2 V/div. Bandwidth, dc to at least 200 kHz.

Input Impedance — 1 MΩ ±2% paralleled by ≈62 pF.

DISPLAY

CRT — 8 x 10 div (0.6 cm/div) display. P44 Phosphor. 2 kV accelerating potential.

Graticule — Internal, non-illuminated. Vertical and horizontal centerlines marked in 5 minor div per major 0.6 cm/div.

Z-Axis Input — Range +5 V to +20 V (dc coupled) with a 100 kHz or greater usable frequency range. Max input voltage, 50 V (dc + peak ac).

STORAGE FEATURES

Display Modes — Direct view, bistable storage, and non-store modes. Enhance mode to increase stored writing rate in the single sweep mode. Auto erase mode to automatically erase stored display after each sweep. Viewing time before auto erase can be varied from 1 sec or less to at least 5 sec. Integrate mode increases stored brightness of very fast repetitive signals.

Stored Writing Speed — Normal, at least 80 div/ms. Enhanced, increases to at least 400 div/ms (250 cm/ms) in enhanced mode.

Erase Time — 300 ms.

ENVIRONMENTAL CAPABILITIES

Ambient Temperature — Operating: -15°C to +55°C. Non-operating: -40°C to +75°C.

Altitude — Operating: to 20,000 ft max, decrease max temperature by 1°C/1000 ft from 5000 ft to 20,000 ft. Nonoperating: 50,000 ft max.

Vibration — Operating: 15 minutes along each of the three major axes, 0.06 cm (0.025 in) p-p displacement (4 g's at 55 Hz) 10 to 55 to 10 Hz in 1 minute cycles.

Humidity — Nonoperating: 5 cycles (120 hours) of MIL-Std-202D, Method 106C. Omit freezing and vibration and allow a post-test drying period at 25°C ±5°C and 20% to 80% relative humidity.

Shock — Operating and nonoperating: 30 g's, 1/2 sine, 11 ms duration each direction along each major axis. Total of 12 shocks.

OTHER CHARACTERISTICS

Amplitude Calibrator — 0.5 V accurate ±1% from 20°C to 30°C, ±2% from -15°C to +55°C.

Power Sources — External ac source, 90 V to 132 V or 180 V to 264 V with a line frequency of 48 Hz to 440 Hz. Max power dissipation 29 W at 115 V. External dc source, +11 V to +14 V or +22 V to +28 V with a max current drain of 1.6 A at +12 V or 0.8 A at +24 V.

PHYSICAL CHARACTERISTICS

| Dimensions | cm | in |
|-----------------------------|------|------|
| Height (w/o pouch) | 11.2 | 4.4 |
| Width (with handle) | 23.6 | 9.3 |
| Depth (handle not extended) | 34.7 | 13.6 |
| Depth (handle extended) | 44.8 | 17.6 |
| Weights (approx) | kg | lb |
| Net (without accessories) | 4.7 | 10.5 |
| Shipping | 7.6 | 17.0 |

INCLUDED ACCESSORIES

Two P6149 10X probes (010-6149-03), carrying case and pouch (016-0612-00), external dc cable assembly (012-0406-00); strap (346-0131-00), two 1.6-A fuses (159-0098-00), two 0.8-A fuses (159-0132-00), two 0.15-A fuses (159-0130-00), three 0.16-A fuses (159-0131-00).

ORDERING INFORMATION

314 Storage Oscilloscope \$3345

The SONY®/TEKTRONIX® 314 is manufactured and marketed in Japan by Sony/Tektronix Corporation, Tokyo, Japan. Outside of Japan the 314 is available from Tektronix, Inc., its marketing subsidiaries and distributors.

RECOMMENDED CAMERA

C-30BP General Purpose Camera \$1245

Camera Adapter—Mounts C-30BP to 314.

Order 016-0327-01 \$165

For further information see Camera section.



214

500 kHz, 1 mV/div to 50 V/div

Internal Battery

Integral 1 MΩ Probe

Weights ≈ 1.6 kg, (3.5 lb)

The 214 features these signal acquisition capabilities: bandwidth to 500 kHz with deflection factors from 1 mV/div to 50 V/div. It is lightweight (only 3.5 pounds) and compact (3 x 5.25 x 9.5 inches). The 214 offers storage capabilities. This is useful for viewing non-repetitive or slow moving signals.

Built of impact-resistant plastic and fully self contained, this miniature portable is ideal for applications in severe environments. And it permits "floating" measurements since it is double insulated and can be elevated to 700 V (dc + ac) above ground when operated from batteries. Although insulated, normal caution should be observed when connecting the oscilloscope probe to the test point.

The 214 features integral probes that are color matched with the vertical deflection controls to minimize measurement error. The probes have their own storage space and are part of the instrument—you can't forget and leave them behind. Clip-on 10X attenuators are available for higher voltage applications.

Trigger level and slope functions are simplified to one rotary control on the side of the unit. A convenient neckstrap is an included accessory, freeing both hands to perform other tasks.

In the single sweep mode the 214 can be set to wait for, then record, a single event. With this feature, the scope's sweep circuit is armed and will wait for the signal to arrive before it runs. When the signal occurs, the sweep runs once. When combined with storage, this provides the unique capabilities of automatically waiting for an event and then storing it for subsequent viewing.

VERTICAL DEFLECTION

Bandwidth — Dc to at least 500 kHz from 10 mV/div to 50 V/div, reducing to at least 100 kHz at 1 mV/div. Lower -3 dB point ac coupled is <2 Hz.

Deflection Factors — 1 mV/div to 50 V/div (1-2-5 sequence), accurate ±5%. Uncalibrated, continuously variable between steps to at least 125 V/div.

Display Modes — Ch 1 only, Ch 2 only, or Ch 1 and Ch 2 chopped (≈ chop rate — 40 kHz) from 500 ms/div to 2 ms/div of time base, alternate from 1 ms/div to 5 μs/div of time base.

Input R and C — ≈ 1 MΩ paralleled by ≈ 160 pF from 1 mV/div to 50 mV/div; and 140 pF from 100 mV/div to 50 V/div.

Max Input Voltage (1X probe only) —

| | |
|-----------------------|---|
| 1 mV/div to 50 mV/div | 600 V (dc + peak ac) ac not over 2 kHz. |
| 0.1 V/div to 50 V/div | 600 V (dc + peak ac) 600 V p-p ac 5 MHz or less |

HORIZONTAL DEFLECTION

Time Base — 5 μs/div to 500 ms/div, accurate ±5%.

Variable Magnifier — Increases each sweep rate X5 with a max sweep speed of 1 μs/div.

External Horizontal Input — (Ch 1) 1 mV/div to 50 V/div ± 10%; dc to 100 kHz; X-Y phasing to 5 kHz <3°. Input characteristics same as Ch 1.

Max External Horizontal Input Voltage and Impedance — Same as for vertical inputs.

Input Impedance — R and C, 1 MΩ paralleled by ≈30 pF.

TRIGGER

Trigger Modes — Automatic or normal. Level and slope selected with a single control. Automatic operation minimizes trigger adjustment and provides a bright baseline with no input.

Trigger Sensitivity and Coupling

| Coupling | | to 500 Hz |
|----------|---------------------------------------|-----------|
| Dc | Internal (w/composite trigger source) | 0.2 div |
| | Internal (w/Ch 2 trigger source) | 0.2 div |
| | External | 1 V |

Max External Trigger Input Voltage — 8 V (dc + peak ac), 16 V (p-p) at 1 MHz or less.

Single Sweep — Sweep generator produces one sweep when trigger is received.

DISPLAY

CRT — Bistable storage, 6 x 10 div (0.52 cm/div) display, P44 Phosphor.

Graticule — Internal, black line, non-illuminated.

STORAGE FEATURES

Stored Writing Speed — Normal, at least 80 div/ms. Enhanced, increases single-sweep storage writing speed to at least 500 div/ms. Enhance is automatic from 0.1 ms to 5 μs/div in single sweep.

Stored Luminance — At least 8 fL at 25°C.

Storage Viewing Time — ≈ 1 hr.

ENVIRONMENTAL CAPABILITIES

Ambient Temperature — Operating: (battery only), -15°C to +55°C. Charging or operating from ac line, 0°C to +40°C. Nonoperating: -40°C to +60°C.

Altitude — Operating: 25,000 ft, decrease max temperature by 1°C/1000 ft above 15,000 ft. Nonoperating: 50,000 ft.

Vibration — Operating and nonoperating: 15 minutes along each of the 3 major axes, 0.06 cm (0.025 in) p-p displacement (4 g's at 55 Hz) 10 to 55 to 10 Hz in one minute cycles. Held for three minutes at 55 Hz.

Humidity — 5 cycles (120 hours) to 95% relative humidity, referenced to MIL-E-16400F.

Shock — Operating and nonoperating: 150 g's, 1/2 sine, 2 ms duration in each direction along each major axis. Total of 12 shocks.

OTHER CHARACTERISTICS

Power Sources — Internal NiCd batteries provide ≈3.5 to 5 hours operation (≈2.5 to 3.5 hours in 214 stored mode) for a charging and operating temperature between 20°C and 30°C. Internal charger charges the batteries when connected to an ac line with instruments turned off. Battery operation is automatically interrupted when battery voltage drops to ≈10 V to protect batteries against deep discharge. Full recharge requires ≈ 16 hours. Extended charge times will not damage the batteries.

A pilot light battery-charge indicator light will extinguish when oscilloscope has about 5 min of operating time remaining in the batteries.

External Ac Source — 110 to 126 V, 58 to 62 Hz, 3 W. Can be operated at 104 to 110 V with resulting slow discharge of internal batteries.

Insulation Voltage — 500 V RMS or 700 V (dc + peak ac) when operated from internal batteries, with the line cord and plug stored. When operated from ac, line voltage plus floating voltage not to exceed 250 V RMS; or 1.4X line + peak ac) not to exceed 350 V.

PHYSICAL CHARACTERISTICS

| Dimensions | cm | in |
|---------------------------|------|-----|
| Height | 7.6 | 3.0 |
| Width | 13.3 | 5.3 |
| Depth | 24.1 | 9.5 |
| Weights (approx) | kg | lb |
| Net (without accessories) | 1.6 | 3.5 |
| Shipping | 3.2 | 7.0 |

INCLUDED ACCESSORIES

Viewing hood (016-0199-01), carrying case (016-0512-00), two 4-A fuses (159-0121-00), identification tags (000-7983-00), identification tag (334-2614-00), carrying strap (346-0104-00).

ORDERING INFORMATION

214 Dual-Trace Storage Oscilloscope, Including Batteries \$2100

POWER OPTIONS

Option 01 for 220-250 V, (48 to 52 Hz) includes batteries No Charge

Option 02 for 90 to 110 V, (48 to 52 Hz) includes batteries No Charge

OPTIONAL ACCESSORIES

10X Attenuator Package — A slip-on tip to provide lower circuit loading (4.4 MΩ, ≈20 pF) and higher max input voltage 1000 V (dc + peak ac) includes: 10X attenuator (010-0378-01); pincher tip (013-0071-00); flex tip (206-0060-00); banana tip (134-0013-00); IC adapter (206-0203-00).

Order 010-0378-01 \$45

Alligator Clip Kit — A pair of alligator clips that allow connecting the probe (or optional 10X attenuator) and ground lead to large (up to 3/8 in) conductors. Includes: red clip (015-0229-00); yellow clip (015-0230-00); 6-32 to probe adapter (103-0051-01).

Order 015-0231-00 \$16

Probe-tip to BNC Panel Connector Adapter
Order 013-0084-01 \$8.00

Probe-tip to BNC Cable Adapter
Order 103-0096-00 \$10.50

Power Cable Adapter Assembly — A short length of two-wire power cord. One end has a female NEC socket fitting the 200 Series power cords; the other end is left open so that the wires can be attached to a non-NEC male power plug. Plugs not supplied.

Order 161-0077-01 \$7.00

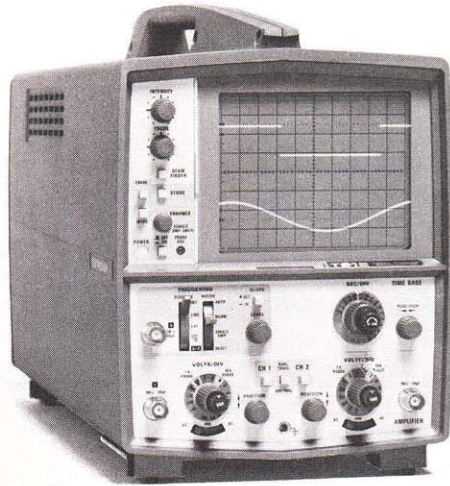

T912

- 10 MHz at 2 mV/div**
- 250 cm/ms Stored Writing Speed**
- 50 ns/div Sweep Rate (with X10 Sweep Magnifier)**
- 8 x 10 cm Bistable Storage CRT**
- Weights ≈ 7.9 kg, (17.5 lb)**
- Differential Input Option**

The T912 Storage Oscilloscope is well suited for a wide range of applications in education and industry. As a training aid in basic electricity and electronics courses, the storage feature is highly useful in creating visual representations of electrical signals. In physics and engineering courses, storage permits the user to capture and display single-shot events like the pressure curve generated in the chamber of an engine or the stress-strain characteristics of a material undergoing destructive testing.

The T912 has similar industrial applications, where it can also be used to compare input vs feedback signals in servo-mechanisms, for shock and vibration analysis, and countless other transducer-aided measurements.

Besides bistable storage, the T912 offers other features seldom found in economy-model oscilloscopes. These include a delay line, which allows you to view the leading edge of fast-rising signals; a 12-step calibrated vertical attenuator; constant bandwidth throughout the sensitivity range of 10 V to 2 mV per centimeter; 19 calibrated sweep rates ranging from 0.5 s to 500 ns/cm; 3% amplitude and timing accuracy; and minimal corner shift over a broad vertical dynamic range.

The T912 may be ordered with a differential input option. In DIFF mode, the T912 displays the difference between Channel 1 and Channel 2 signals. The Channel 2 signal is automatically inverted: The algebraic sum of the Channel 1 signal and the inverted Channel 2 signal is then displayed on the CRT.

VERTICAL SYSTEM

Mode Selection

- Ch 1** — Displays only the Ch 1 signal.
- Ch 2** — Displays only the Ch 2 signal.
- Dual Trace** — Displays Ch 1 and Ch 2 signals simultaneously. Alternate or chopped mode is automatically selected by the SEC/DIV control setting, chopped mode is selected for settings ≥ 1 ms/div, alternate for settings ≤ 500 μ s/div. Trigger is derived from Ch 1 signal only.

Deflection Factor

- Range** — 2 mV/div to 10 V/div in 12 steps in a 1-2-5 sequence.
- Accuracy** —

| | |
|----------------|-----------|
| +20°C to +30°C | Within 3% |
| 0°C to +45°C | Within 4% |

Uncalibrated (VAR) Range — Continuously variable between settings. Extends deflection factor to at least 25 V/div.

Frequency Response — Dc to at least 10 MHz (measured at -3 dB).

- Rise Time** — 35 ns or less.
- Chopped Mode Repetition Rate** — ≈ 250 kHz.

- Input Resistance** — ≈ 1 M Ω .
- Input Capacitance** — ≈ 30 pF.
- Max Input Voltage** —

 - Dc Coupled** — 400 V (dc + peak ac) 800 V p-p ac at 1 kHz or less.
 - Ac Coupled** — 400 V (dc + peak ac) 800 V p-p ac at 1 kHz or less.

Delay Line — Permits viewing edge of displayed waveform.

HORIZONTAL SYSTEM

Calibrated Range — 0.5 s/div to 0.5 μ s/div in 19 steps in a 1-2-5 sequence. Variable X1 to X10 magnifier extends max sweep rate to 50 ns/div.

Accuracy —

| | Unmagnified | Magnified |
|----------------|-------------|-----------|
| +20°C to +30°C | Within 3% | Within 5% |
| 0°C to +45°C | Within 4% | Within 6% |

TRIGGERING

Trigger Mode

- Auto** — Permits normal triggering on waveforms with repetition rate of at least 20 Hz. Sweep "free-runs" in the absence of adequate trigger signal, or one with a repetition rate below 20 Hz.
- Norm** — Permits normal triggering. Sweep does not run in the absence of an adequate trigger signal.
- Single Sweep** — Displays one sweep only. Sweep cannot be triggered again until reset.
- Slope + Out - In** — Sweep is triggered on the positive/negative-going slope of the triggering waveform.
- Level** — Variable control selects the amplitude point on the trigger signal when sweep triggering occurs.

Trigger Sensitivity

Auto and Norm — 0.5 div internal or 100 mV external from 2 Hz to 5 MHz, increasing to 1.5 div internal or 150 mV external at 10 MHz.

External Trigger Input

- Max Input** — 400 V (dc + peak ac) 800 V p-p ac at 1 kHz or less.
- Input Resistance** — ≈ 1 M Ω .
- Input Capacitance** — ≈ 30 pF.

X-Y OPERATION

- Sensitivity, Variable Magnifier** — ≈ 100 mV/div (X10 mag), ≈ 1 V/div (X1 mag), for X; Y is adjusted by vertical control.
- X-Axis Bandwidth** — Dc to at least 1 MHz (measured at -3 dB).
- Input Resistance** — ≈ 1 M Ω .
- Input Capacitance** — ≈ 30 pF.
- Phase Difference Between X and Y Axis Amplifiers** — Within 5° from dc to 50 kHz.

CRT STORAGE DISPLAY

- Writing Rate** — At least 25 cm/ms.
- Enhanced Writing Rate** — At least 250 cm/ms.
- Display Area** — 8 x 10 cm, internal graticule.
- Storage Phosphor** — P1.
- Beam Finder** — Locates off-screen display.
- Nominal Accelerating Potential** — ≈ 2.76 kV.

POWER SOURCE (AC)

- Line Voltage Ranges** — HI-LO range accessible externally; 110-120 V, 220-240 V line selector visible but not accessible externally.
- 100-120 V Range** — HI: 108 to 132 V RMS. LO: 90 to 110 V RMS.
- 220-240 V Range** — HI: 216 to 250 V RMS. LO: 198 to 242 V RMS.
- Line Frequency** — 50 to 60 Hz.
- Power Consumption** — Watts (max) 65, amps (max) 0.6, at 120 V, 60 Hz.

PROBE ADJUST

- Output Voltage** — ≈ 0.5 V.
- Repetition Rate** — ≈ 1 kHz.

Z-AXIS INPUT

- Sensitivity** — 5 V causes noticeable modulation.
- Usable Frequency Range** — Dc to 5 MHz.
- Input Impedance** — ≈ 10 k Ω .

ENVIRONMENTAL CAPABILITIES

Temperature

- Nonoperating** — -55°C to +75°C.
- Operating** — 0°C to +45°C.

Altitude

- Nonoperating** — To 15,200 meters; 50,000 ft.
- Operating** — To 4,500 meters; 15,000 ft max. Operating temperature decreased 1°C/304.8 meters (1,000 ft) above 1524 meters (5,000 ft).

PHYSICAL CHARACTERISTICS

| Dimensions | cm | | in | |
|------------------------|------|------|----|----|
| | cm | in | kg | lb |
| Height | 25.4 | 10.0 | | |
| Width | 18.0 | 7.09 | | |
| Depth | 47.5 | 18.7 | | |
| Weight (approx) | | | | |
| Net (with panel cover) | 8.2 | 18.0 | | |
| Net (w/o panel cover) | 7.9 | 17.5 | | |

INCLUDED ACCESSORIES

Probes — 2 each. P6006 general purpose 10X voltage probes. Provides full bandwidth capabilities for the T912.

ORDERING INFORMATION

- T912 — Storage Oscilloscope (includes two 10X probes)** \$1890
- Option 01, Differential Input** Add \$90
- INTERNATIONAL POWER CORDS & PLUG OPTIONS**
- Option A1 Universal Euro 220 V/16A** No Charge
- Option A2 UK 240 V/13A** No Charge
- Option A3 Australian 240 V/10A** No Charge
- Option A4 North American 240 V/15A** No Charge

OPTIONAL ACCESSORIES



Front Panel Cover

Snaps over the oscilloscope front panel to protect controls during transport or storage. Molded from high-impact-resistant plastic. Storage compartment for two probes and cables is built into inner side.

Order Protective front cover (016-0340-00) \$20

Dust Cover/Rain Jacket (not shown)
Provides protection against dust accumulation when not in use, and against rain and snow during transportation. Constructed of 15 mil tough durable vinyl. An opening at the top allows access to the oscilloscope handle.

Order Protective cover (016-0361-00) \$20

C-5C Camera (not shown)
Order C-5C, Option 03 \$500

GENERAL PURPOSE INSTRUMENTS

CONTENTS

| | |
|---------------------------------------|-----|
| Digital Multimeters | 254 |
| Counter/Timers | 258 |
| Power Supplies | 265 |
| Digital Delay | 267 |
| Digital Latch | 267 |
| Word Recognizer | 267 |
| Pulse Generators | 268 |
| Function Generators | 272 |
| Current Probes | 277 |
| Amplifiers | 278 |
| Calibration Generators | 279 |
| Distortion Analyzer, Oscillator | 284 |
| Plug-In Oscilloscopes | 286 |
| Interface & Scanner | 290 |
| Controllers | 292 |
| Mainframes | 295 |
| Accessories | 298 |

Designed for Configurability; for Programming Ease; for Productivity.

Test and Measurement set-up has never been this friendly, has never been this fast. With our new line of Tek programmables, you can continue to build on the concept of configurability.

Now you can link together customized, automated test packages over the GPIB bus. Our IEEE-488 compatible TM 5000 programmables are configurable, with the same plug-in, pull-out ease as our TM 500 plug-ins. And they're compatible, between themselves and with over 40 TM 500 manual instruments.

You'll find these fully programmable instruments are among the friendliest and fastest to integrate you can buy.

Standardized instrument data formats open up the lines of bus communication, and makes your test and measurement system easy to set-up and operate. Or change its test and control functions quickly and easily.

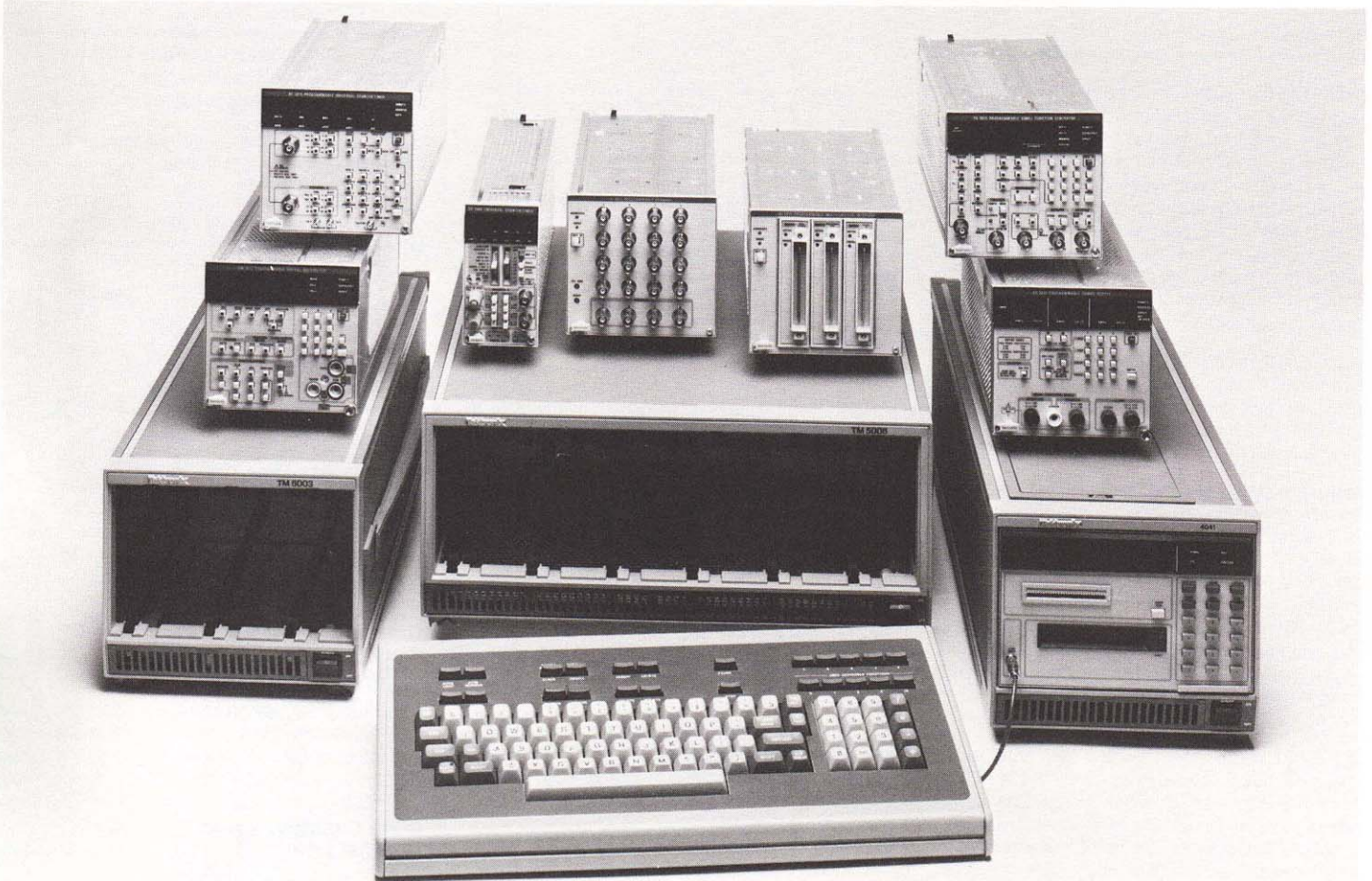

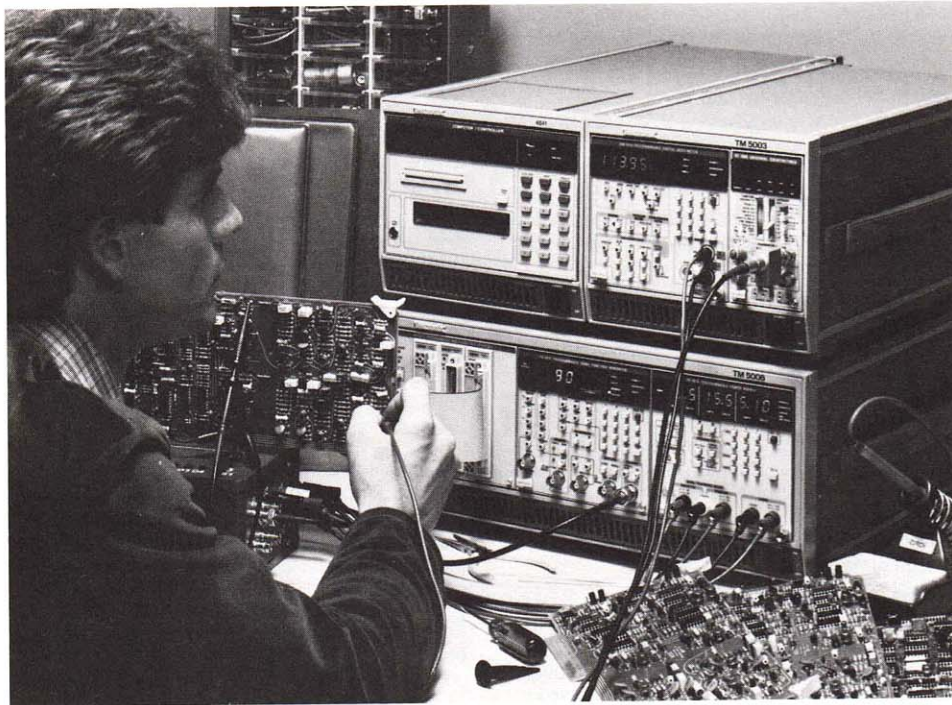

With the LEARN mode, you input simple routines to the controller directly from the instrument via front panel settings. And you can change a routine when necessary without having to reprogram the whole system.

Start with our two new mainframes, the TM 5003 and TM 5006.

They hold up to three or six plug-ins, yet they're very compact. So your test package takes up less than half the space of ordinary rackmounted test equipment.

Add our new instrument-optimized controller, the 4041. It has a detachable keyboard that you attach for program development and detach for program protection. Built around a 16-bit microprocessor with 160k byte memory capacity, this sophisticated controller offers two GPIB and two RS-232 ports (with Option 01), so you can optimize system set-up. And three data transfer speeds: normal, fast transfer and DMA. So you can optimize program run-time.

Choose your programmable test gear from our fully programmable Function Generator (the FG 5010), Universal Counter/Timers (DC 5010 and DC 5009), Digital Multimeter (DM 5010), and Power Supply (PS 5010) and incorporate TM 500 Plug-ins for special functions.

The vital link between your specific device under test and the programmable system, is the multifunction interface, MI 5010. The multifunction interface acts as the "systems glue" for your application. The multifunction interface is a cardbased instrument. To customize its' capabilities you choose from three available function cards: Digital I/O card, Relay Scanner card and to customize your own card, a Development card. For additional card capacity an extender is available.

Simplify system routing and switching with a Scanner Interface. The SI 5010, lets you preset a 16-channel, software configurable RF switching matrix to make test connections on command.

Manual instruments that perform in hundreds of combinations.

Configurability is the watchword for TM 500 Instruments and Mainframes. You can create multifunction packages that encompass a wide diversity of applications. Or solve one unique application problem.

You choose from over forty ready-to-go, compact plug-ins for a range of test and measurement needs. TM 500 Instruments include digital counters, pulse generators, function generators, amplifiers, signal processors, audio oscillators, a distortion analyzer, ramp generators, calibration instruments, power supplies, oscilloscopes, digital delay, word recognizer, and a digital latch. Plus a blank plug-in kit for customizing special functions.

You put your instruments together in the mainframe that best suits your environment. There's a travel mainframe for service work and field testing. A rackmount model for production and test.

Or standard mainframes, compact and convenient for bench or desk, that accept one or up to six instruments. Rollabout carts are available for lab configurations with Tek oscilloscopes.

All TM 500 Instruments and Mainframes are electrically and mechanically compatible. So through interfacing you can configure an instrument more powerful than the sum of its parts: An audio lab with distortion analyzer and storage scope, for example.

Cost efficiency is as important a part of the TM 500 concept as solving applications problems is. You add on performance capabilities when you need them. And when you do add them, you can still use the same mainframe and power supply you started with.

PROGRAMMING EASE . . .

Another Order of Magnitude in Measurement Convenience

TM 5000 Programming... A Commitment to Compatibility

The new TEKTRONIX TM 5000 Series of instruments is, in many respects, the same as its predecessor, the TM 500 Series. There's the same range of instruments — digital multimeter, universal counter/timers, triple power supply, function generator, and others. And there's the same commitment to excellence in each instrument.

It's the additions and enhancements that make TM 5000 something new. First, each TM 5000 Plug-in Instrument is programmable. Plus, there are new kinds of plug-ins — a Programmable R.F. Scanner and a Programmable Multifunction Interface — for further test automation. And every instrument is compatible with IEEE Standard 488-1978, the instrument interfacing standard specifying what is often called the General Purpose Interface Bus or GPIB.

TM 5000 Speaks Your Language

With TM 5000, compatibility is the key. And it's more than just IEEE-488 compatibility. It's total system compatibility, from configuring to programming. This higher level of compatibility is achieved through conformance to the additional standard of TEK *Codes and Formats*, the same standard governing other Tektronix IEEE-488-compatible products, including a variety of instrument controllers, waveform digitizers, and special signal analyzers. TM 5000 and Tek *Codes and Formats* extend compatibility through:

- An ASCII-coded language for easy, English-like programming.
- Command names that are descriptive abbreviations of instrument functions for simple and direct instrument control.
- Universal message and data formats for instrument-to-instrument consistency.

In short, TM 5000 Instruments speak a system language that is the same as your language.

Need to set your power supply to five volts?

It's easy with the TM 5000 Series Programmable Power Supply. Just send the message VPOS 5 over the IEEE-488 bus to the power supply, and it will change its positive output to five volts.

Want to set the negative supply to -9 volts? Just send VNEG 9, or even VNEG -9. All the TM 5000 Instrument commands are simple, English abbreviations for the instrument functions, with direct matches to the front-panel control labels where appropriate. So, if you know how to operate the instrument, you essentially know what commands to send it.

What could be simpler than DCV .2 to change your TM 5000 Programmable Multimeter to the 200 millivolt range for dc voltage measurements? Or ACV 2 to switch it to the 2 volt range for ac measurements? But then, you may not always be sure of the range you need. So just send DCV or ACV without specifying the range, and the multimeter will auto-range to give you the best measurement. You don't have to learn a new language to speak to an instrument or understand instrument control messages — they're self documenting.

Getting Your Message Across

It doesn't take long to become familiar with the command set for any TM 5000 Instrument. And, once you have that familiarity, you'll want to begin actually programming for automated measurements. First, though, you'll need to know something about IEEE-488 bus communication.

IEEE Standard 488 specifies overall bus functioning, leaving many implementation options to designer discretion. One option is how controllers and instruments signal message endings to each other. Some controllers end messages by asserting End Or Identify (EOI) concurrent with sending the last character of a message, others by adding a line feed (LF) character and asserting EOI concurrent with that. For compatibility, your instruments and controller must use the same message termination mode.

Whatever your choice of IEEE-488 instrument controller, TM 5000 Instruments are designed for compatibility. A switch on each TM 5000 Instrument lets you match it to your controller by selecting the EOI only or EOI/LF message termination mode. But, if you've chosen a Tektronix controller, you won't have to bother with this switch. All Tektronix-supplied instrument controllers use EOI only, and all TM 5000 Instruments are shipped set for EOI only.

Along with the message terminator switch, you'll also find that each TM 5000 Instrument has a bank of at least five additional switches. These are used to set the instrument's primary bus address.

For an IEEE-488 system to work, each instrument on the bus must have a different address. Valid addresses range from 0 to 30, with 0 reserved in some cases for the controller. Before connecting your TM 5000 Instrument to the IEEE-488 bus, make sure each instrument is set to a different address. For powered-up instruments, address checks can be done with the INST ID button. Pressing INST ID causes the address to appear on the instrument's display. Also, a decimal point will be displayed after the address if the message terminating mode is set for EOI/LF; absence of a decimal indicates EOI only.

The primary address serves two major functions. First, it links the controller to a specific instrument. Second, the primary address, when increased by a specific amount, determines whether the instrument is to "listen" for a message or to send data by "talking".

An instrument's listen address is its primary address plus 32, and its talk address is its primary address plus 64. So an instrument with a primary address of 20 will have a listen address of $20 + 32 = 52$, a talk address of $20 + 64 = 84$.

In most cases, you won't have to worry about listen and talk addresses. For example, when using a TEKTRONIX 4050-Series Controller with 4050 BASIC Software, just primary addresses are used. 4050 BASIC automatically converts primary addresses to talk and listen addresses. For example, here's a 4050 BASIC statement for sending VPOS 5 to a PS 5010 Programmable Power Supply with a primary address of 22 —

```
PRINT @22:"VPOS 5"
```

PRINT is the 4050 BASIC statement for sending a message to an instrument. The instrument's primary address, 22 in this case, is always preceded in the statement by an "at" sign (@) and followed by a colon. The instrument message, VPOS 5, follows the colon and is always enclosed in quotes. Since the instrument will be receiving the message, PRINT causes the primary address to be automatically incremented to a listen address.

Keep in mind, though, PRINT @22:"VPOS 5" is a statement format specific to 4050 BASIC. Other instrument controllers and software packages may use different statement formats, however the device dependent message is always the same.

In addition to being easy to program, TM 5000 Instruments are friendly and informative in respect to sending SRQ interrupts.

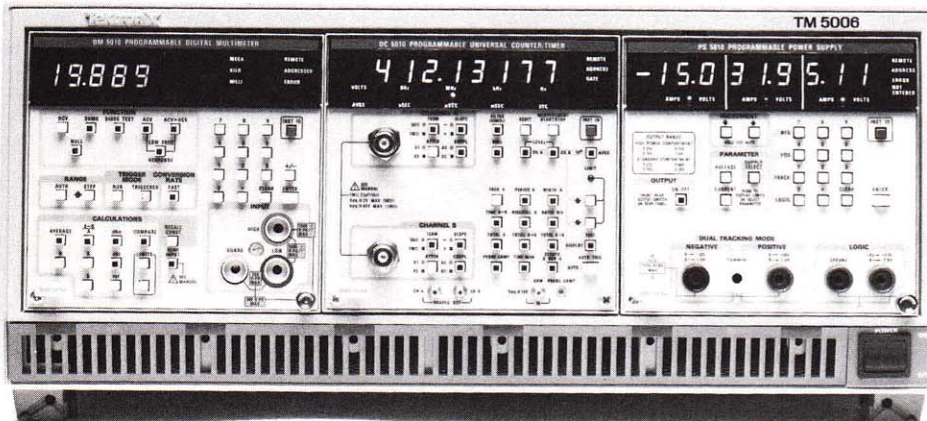

TM 5000: IEEE-488 compatibility in an attractive high density package for minimum use of bench top or system rack space.

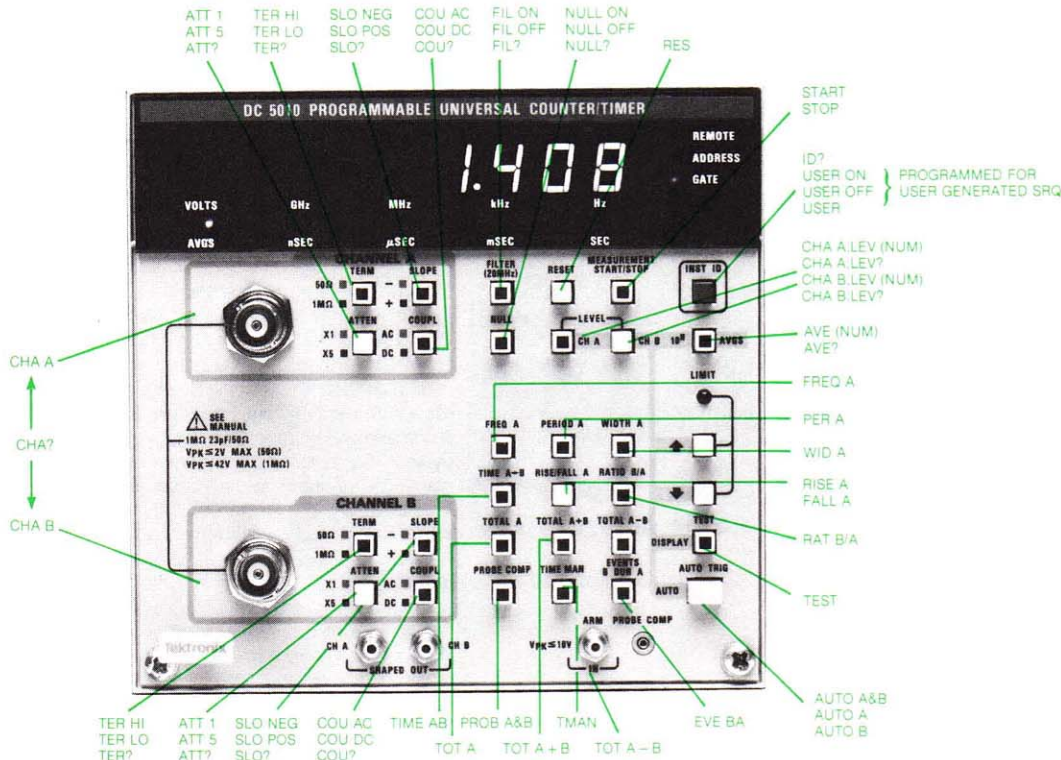

TM 5000 means friendly "front-panel" commands for easy instrument programming...

We Interrupt this Message for a Brief Program

With the basic message format in mind, you are ready to begin sending messages to your instruments. However, you should be aware that your instruments can occasionally interrupt what you are doing by asserting what is called an SRQ (Service Request).

The INST ID button can also be found on each TM 5000 plug-in programmed (USER ON) to generate an SRQ when it is pressed. This manually generated SRQ is a convenient way for you to interrupt and interact with measurement programs while they are running.

Queries Keep You Posted

A TM 5000 error code scheme allows individual instruments to expand on the universal IEEE-488 system status codes. This expansion is the result of an extensive message decoding system that checks for syntax errors, illegal combinations, etc. before messages can affect instrument operation. Illegal setups are prevented, and specific, rather than generalized, error codes are available for each instrument. These error codes can be read over the IEEE-488 bus by sending the instrument an error query message (ERR?).

You'll also want to be able to get specific information about instrument settings, measurement modes, etc. This type of information can be obtained with various instrument query messages.

All TM 5000 queries take the form of a keyword followed by a question mark. You send the query to the instrument as a message, and the instrument answers the query by returning a message

over the bus. For example, here's a query sequence in 4050 BASIC to obtain the positive voltage setting of a TM 5000 Programmable Power Supply.

```
PRINT @22:"VPOS?"
INPUT @22:V$
```

The first statement in this example questions the instrument: "What is your positive voltage setting?" The instrument answers by getting the setting and putting it onto the bus as a message, VPOS 5 for example. The INPUT statement is the means of receiving the message and storing it in string variable V\$. When a string variable (alpha character followed by \$) is used with the INPUT statement, the entire message is stored in the variable.

Perhaps you are interested in all the control settings of an instrument. SET?, a universal query for all TM 5000 Instruments, causes the queried instrument to send a message that lists all of its current settings. This entire settings message can then be stored in a string variable. (Since the settings message can be several hundred characters long, it may be necessary with some software packages to extend or dimension the string variable to a length capable of holding the message.)

The SET? feature allows you to acquire and store a number of instrument configurations in different string variables. Then, just by sending the appropriate string variable to an instrument, the instrument can be reset at any time to any of the stored configurations.

In essence, SET? is a "learn mode" of operation. It allows your software to "memorize" instrument setups for later use.

If you'd like to experiment with this, set your instrument to a familiar measurement configuration. Using 4050 BASIC, enter the following statements (20 is assumed here to be the address of a DC 5010 Programmable Counter and S\$ is set to a 300-character length to be sure to accommodate all of the instrument's settings).

```
DIM S$(300)
PRINT @20:"SET?"
INPUT @20:S$
```

Now change several of the settings. Then enter the following statement.

```
PRINT @20:S$
```

The instrument will switch its settings back to those stored in S\$.

Would you like to see what is in S\$? Just enter PRINT S\$. The entire settings message will be printed out on the terminal screen for your inspection.

Each TM 5000 Instrument responds to a variety of queries, each query consisting of a keyword specific to the information desired. Would you like to know what measurement function your DM 5010 Programmable Digital Multimeter is set up for? Just send it "FUNC?" and the DM 5010 will prepare to send back DCV, OHMS, DIODE, ACV, or ACDCV and the measurement range the function is set for. Send the same query to your FG 5010 Programmable 20 MHz Function Generator, and it'll prepare to send back FUNC SINE, FUNC SQUARE, OR FUNC TRIANGLE, depending on the waveform it is generating. Just another example of how TM 5000 Instruments work with you in plain English.

The addition of the new DM 5010 to the Tektronix line of Digital Multimeters brings full programmability, IEEE-488 compatibility, and TM 500 modularity/versatility together for the first time. Excellent performance, local math capability, and the programming ease of a high level language make the DM 5010 an attractive link in any IEEE-488 system requiring a digital multimeter.

TM 500 Digital Multimeters offer a compact solution to your measurement needs without compromising wide performance range. The DM 502A and the DM 501A offer accuracy and flexibility in laboratory, bench, field service and maintenance applications.

The DM 501A gives 4 1/2 digits of readout resolution. And seven distinct measurement functions, with 0.05% dc volts accuracy and true RMS capability. The DM 502A adds testing convenience through autoranging. Seven full functions are displayed on 3 1/2 digits.

With full-scale precision measuring capabilities, backed by Tektronix design and engineering expertise, the DM 5010, DM 502A and the DM 501A, are designed for almost any test and measurement application.

DM 5010



Programmable Digital Multimeter

NEW
DM 5010

GPIB
IEEE-488

The DM 5010 is designed to comply with IEEE Standard 488-1978 and with Tektronix *Codes and Formats Standard*.

Fully Programmable

4.5 Digit, .015% Accuracy

Autoranging

Math Functions (dB, average, offset, scale, HI/LO/PASS test)

True RMS

Diode Test

DIGITAL MULTIMETER SELECTION CHART

| Model Number | Number of Digits | Number of Functions | DC Volts | | | AC Volts | | | AC+DC Current | dB | Ohms (HI-LO) | Temp | True RMS | Auto Range | IEEE 488 |
|--------------|------------------|---------------------|------------------|----------|-----------------|-----------------|----------|-----------------|---------------|------------------|----------------|-----------------|----------|------------|----------|
| | | | Ranges | Accuracy | Best Resolution | Ranges | Accuracy | Best Resolution | Ranges | Ranges | Ranges | Range | | | |
| DM 501A | 4½ | 7 | 200 mV to 1000 V | ±0.05% | 10 µV | 200 mV to 500 V | ±0.6% | 10 µV | 200 µA to 2 A | +54 dB to -60 dB | 200 Ω to 20 MΩ | -62°C to +240°C | X | | NO |
| DM 502A | 3½ | 7 | 200 mV to 1000 V | ±0.1% | 100 µV | 200 mV to 500 V | ±0.6% | 100 µV | 200 µA to 2 A | +50 dB to -60 dB | 200 Ω to 20 MΩ | -55°C to +200°C | X | X | NO |
| DM 5010 | 4½ | 8 | 200 mV to 1000 V | ±0.015% | 10 µV | 200 mV to 700 V | ±0.2% | 10 µV | Calculated | | 200 Ω to 20 MΩ | | X | X | YES |

The fully programmable DM 5010 measures dc voltage, resistance, true RMS ac voltage, and true RMS (ac+dc) voltage. The OHMS Function allows in-circuit resistance measurements without turning on diode and transistor junctions. A DIODE TEST Function is provided for testing diode and transistor junctions. All controls and features of the DM 5010 are fully addressable via the GPIB. The English-like programming commands make GPIB control exceptionally straightforward. The front panel controls may be used in conjunction with the GPIB or may be "locked out" entirely. Measurements and calculations are triggered via internal circuitry, a front panel pushbutton, a rear interface connector, or a GPIB command. Measurement rates of 3 readings/second at 4.5 digit resolution and 26 readings/second at 3.5 digit resolution are available. Powering up the DM 5010 automatically initiates the instrument's self-test cycle. The autoranging feature eliminates the need for operator-selected ranges. The math functions resident in the DM 5010 allow: averaging of up to 19,999 readings; calculation of dB referenced either to 1 mW and 600 Ω or to an operator-supplied constant; offsetting of measurements by an operator-supplied constant; scaling of measurements by an operator-supplied constant; comparing measurements to operator-supplied upper and lower limits (DM 5010 responds with HI/PASS/LO); or any combination of these. It should be noted that through the use of an external shunt resistor and a scaling factor equal to the shunt resistor, current values may be displayed directly on the DM 5010 display. A single button NULL function provides rapid nulling in any mode. A special LOW FREQUENCY RESPONSE function provides stable readouts at low frequency ac voltages.

DM 5010 CHARACTERISTICS

DC VOLTS

Ranges — 200 mV, 2 V, 20 V, 200 V, 1000 V.

Accuracy — 6 months or 1000 hours.

| 18°C to 28°C | Normal | Fast |
|-------------------------|---|---|
| | Conversion Rate | Conversion Rate |
| 200 mV range | ±(0.015% of reading + 0.01% of full scale) | ±(0.05% of reading + 0.05% of full scale) |
| 2 V through 200V ranges | ±(0.015% of reading + 0.005% of full scale) | ±(0.05% of reading + 0.05% of full scale) |
| 1000 V range | ±(0.020% of reading + 0.010% of full scale) | ±(0.05% of reading + 0.1% of full scale) |

| 0°C to 18°C, 28°C to 50°C | Normal | Fast |
|---------------------------|---|--|
| | Conversion Rate | Conversion Rate |
| 200 mV range | ±(0.06% of reading + 0.035% of full scale) | ±(0.1% of reading + 0.1% of full scale) |
| 2 V through 200 V range | ±(0.06% of reading + 0.03% of full scale) | ±(0.1% of reading + 0.1% of full scale) |
| 1000 V range | ±(0.065% of reading + 0.035% of full scale) | ±(0.1% of reading + 0.15% of full scale) |

Common Mode Rejection Ratio —

Unguarded: ≥130 dB at dc, ≥80 dB at 50 to 60 Hz.

Guarded: ≥140 dB at dc, ≥100 dB at 50 to 60 Hz.

Normal Mode Rejection Ratio —

Normal Conversion Rate — ≥40 dB at 50 or 60 Hz ±0.2 Hz.

Fast Conversion Rate — ≥40 dB at 50 or 60 Hz ±0.2 Hz.

Maximum Resolution — 10 µV.

Step Response Time (To Rated Accuracy) —

RUN Mode: Normal Conversion rate — ≤0.53 s.

Fast Conversion Rate — ≤0.08 s.

Triggered Mode: Normal Conversion Rate — ≤0.33 s.

Fast Conversion Rate — ≤0.06 s.

Input Resistance —

200 mV — 20 V Range — >10⁹ Ω.

200 V — 1000 V Range — 10 MΩ ±0.25%.

Maximum Input Voltage — 1000 V peak.

TRUE RMS AC VOLTS (AC and AC + DC)

Ranges — 200 mV, 2 V, 20 V, 200 V, 700 V

Accuracy (Normal and Fast Conversion Rate) —

6 months or 1000 hours.

| 18°C to 28°C | 20 Hz to 100 Hz | 100Hz to 20 kHz | 20 kHz to 100 kHz |
|-----------------------------|--------------------------------------|--------------------------------------|--------------------------------------|
| 200 mV through 200 V ranges | ±(0.8% of rdg. + .2% of full scale) | ±(0.2% of rdg. + .2% of full scale) | ±(1.0% of rdg. + 0.5% of full scale) |
| 700 V range (15 kHz Max) | ±(0.8% of rdg. + 0.6% of full scale) | ±(+.2% of rdg. + 0.6% of full scale) | |

0°C to 18°C, 28°C to 50°C

| | ±(1.25% of rdg. + 0.35% of full scale) | ±(0.65% of rdg. + 0.3% of full scale) | ±(1.45% of rdg. + 0.65% of full scale) |
|-----------------------------|--|--|--|
| 200 mV through 200 V ranges | | | |
| 700 V range (15 kHz Max) | ±(1.24% of rdg. + 0.95% of full scale) | ±(0.65% of rdg. + 0.95% of full scale) | -- |

Common Mode Rejection Ratio —

Unguarded: ≥130 dB at dc. ≥80 dB at 50 to 60 Hz.

Guarded: ≥140 dB at dc. ≥100 dB at 50 to 60 Hz.

Maximum Resolution — 10 μV.

Response Time — <1.2 s except for LOW FREQUENCY RESPONSE mode.

Input Impedance — 2 MΩ ± 0.1% paralleled by <150 pF.

Maximum Input Voltage — 1000 V peak ac, 500 V dc.

Crest Factor — 4 (except for 700 V range).

AC + DC VOLTS ONLY

(Normal and Fast Conversion Rate, 10 to 20 Hz)

| ±18°C to 28°C | |
|----------------------------|-------------------------------------|
| 200 mV through 200 V Range | ±(0.8% of rdg + 0.3% of full scale) |
| 700 V Range | ±(0.8% of rdg + 0.9% of full scale) |

0°C to 18°C, 18°C to 50°C

| 200 mV through 200 V Range | ±(1.25% of rdg + .45% of full scale) |
|----------------------------|---------------------------------------|
| 700 V Range | ±(1.25% of rdg + 1.25% of full scale) |

RESISTANCE

Ranges — 200 Ω, 2 kΩ, 20 kΩ, 200 kΩ, 2 MΩ, 20 MΩ.

Accuracy — 6 months or 1000 hours.

| 18°C to 28°C | Normal Conversion Rate | Fast Conversion Rate |
|------------------------|--|---|
| 200 Ω to 200 kΩ ranges | ±(0.015% of reading + 0.01% of full scale) | ±(0.05% of reading + 0.05% of full scale) |
| 2 MΩ range | ±(0.10% of reading + 0.01% of full scale) | ±(0.10% of reading + 0.05% of full scale) |
| 20 MΩ range | ±(0.15% of reading + 0.005% of full scale) | ±(1.0% of reading + 0.05% of full scale) |

0°C to 18°C, 28°C to 50°C

| 200 Ω to 200 kΩ ranges | ±(0.06% of reading + 0.035% of full scale) | ±(0.1% of reading + 0.1% of full scale) |
|------------------------|--|--|
| 2 MΩ range | ±(0.54% of reading + 0.035% of full scale) | ±(0.55% of reading + 0.1% of full scale) |
| 20 MΩ range | ±(0.75% of reading + 0.01% of full scale) | ±(1.6% of reading + 0.05% of full scale) |

Maximum Resolution — 10 mΩ.

Step Response Time (To Rated Accuracy) —

RUN Mode: Normal Conversion Rate — ≤1.24 s.

Fast Conversion Rate — ≤0.33 s.

TRIGGERED Mode: Normal Conversion Rate — ≤0.73 s.

Fast Conversion Rate — ≤0.19 s.

Maximum Input Volts — 400 V peak.

Maximum Open Circuit Voltage Developed — <5 volts.

DIODE TEST

Operation — A 1 mA current is generated and the resultant voltage is measured on the 2 V dc range. This produces a voltage sufficient to turn on diode and transistor junctions.

OTHER CHARACTERISTICS

Overrange Indication — For OHMS and DIODE TEST, "OC" is displayed; for ACV, DCV, ACV + DCV, the display blinks.

Measurement Rate —

ACV, DCV, ACV + DCV, Diode Test

3 per second at 4.5 digits

26 per second at 3.5 digits

Ohms

1.6 per second at 4.5 digits

7.1 per second at 3.5 digits

Power Consumption — ≈20 VA.

GPIB Commands — Addressable by 30 English-like GPIB commands.

INCLUDED ACCESSORIES

1 set Test Leads.

ORDER DM 5010 \$1995

DM 502A

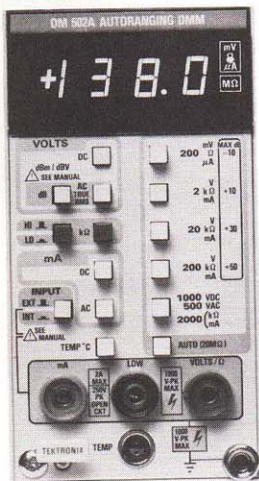

Digital Multimeter

DM 502A

True RMS

Autoranging

Seven Functions including Temperature and dB

0.1 % Dc Volts Accuracy

3 1/2 Digits

The DM 502A Digital Multimeter measures seven different functions with pushbutton convenience. Autoranging, in all modes except current, eliminates any need for operator selected ranges. The DM 502A measures dc and ac voltage, dc and ac current, dB, resistance and temperature. True RMS provides more accuracy in ac measurements on distorted, noisy, random or other non-sinusoidal ac waveforms. The resistance mode features HI-LO voltage (2 V-0.2 V). The low voltage is user-selectable for making in-circuit ohms measurements without turning on diode and transistor junctions. The high voltage is available for testing junctions for forward and reverse resistance. The LED indicators provide a bright, readable 3 1/2 digit display.

DC VOLTS

Ranges — 200 mV, 2 V, 20 V, 200 V, and 1000 V. Automatic or manual ranging.

Accuracy — 6 months or 1000 hours.

18°C to 28°C:

| | |
|------------------------|--|
| 200 mV to 200 V Ranges | ±[0.1% of reading + 0.05% of full scale (1 count)] |
| 1000 V Range | ±[0.1% of reading + 0.1% of full scale (1 count)] |

0°C to 18°C and 28°C to 50°C:

| | |
|------------------------|--|
| 200 mV to 200 V Ranges | ±[0.2% of reading + 0.1% of full scale (2 counts)] |
| 1000 V Range | ±[0.2% of reading + 0.2% of full scale (2 counts)] |

Common-Mode Rejection Ratio — ≥100 dB at dc. ≥80 dB at 50 Hz to 60 Hz with 1 kΩ imbalance.

Normal-Mode Rejection Ratio — ≥50 dB at 50 Hz or 60 Hz ± 0.2 Hz.

Maximum Resolution — 100 μV.

Step Response Time — 1 s within a range, +1.5 s for each range change in autoranging mode.

Input Resistance — 10 MΩ.

Maximum Input Voltage — 1000 V peak.

TRUE RMS AC VOLTS

Ranges — 200 mV, 2 V, 20 V, 200 V, and 500 V. Automatic or manual ranging (ac coupled).

Accuracy — 6 months or 1000 hours.

18°C to 28°C:

| | 20 Hz | 40 Hz | 20 kHz |
|------------------------|--|--|--|
| 200 mV to 200 V Ranges | ±[1.5% of reading + 0.3% of full scale (6 counts)] | ±[1.5% of reading + 0.3% of full scale (6 counts)] | ±[0.6% of reading + 0.3% of full scale (6 counts)] |
| 500 V Range | ±[1.5% of reading + 1.2% of full scale (6 counts)] | ±[1.5% of reading + 1.2% of full scale (6 counts)] | ±[0.6% of reading + 1.2% of full scale (6 counts)] |

0°C to 18°C and 28°C to 50°C:

| | 20 Hz | 40 Hz | 20 kHz |
|------------------------|---|---|---|
| 200 mV to 200 V Ranges | ±[1.8% of reading + 0.35% of full scale (7 counts)] | ±[1.8% of reading + 0.35% of full scale (7 counts)] | ±[0.8% of reading + 0.35% of full scale (7 counts)] |
| 500 V Range | ±[1.8% of reading + 1.4% of full scale (7 counts)] | ±[1.8% of reading + 1.4% of full scale (7 counts)] | ±[0.8% of reading + 1.4% of full scale (7 counts)] |

Typically usable to 100 kHz.

Common-Mode Rejection Ratio — ≥60 dB at 50 Hz to 60 Hz with 1 kΩ imbalance.

Maximum Resolution — 100 μV.

Response Time — 1 s within a range, +1.5 s for each range change in autoranging mode.

Input Impedance — 10 MΩ paralleled by <100 pF.

Maximum Input Voltage — 500 V ac RMS, 600 V dc, not to exceed 1000 V peak.

Crest Factor — 4 at full scale all ranges (≤2 on 500 V range).

dB (TRUE RMS)

Zero dB Reference — 1 mW in 600 Ω (0.775 V) (dBm). Internal jumper change for zero dB reference of 1,000 V (dBV).

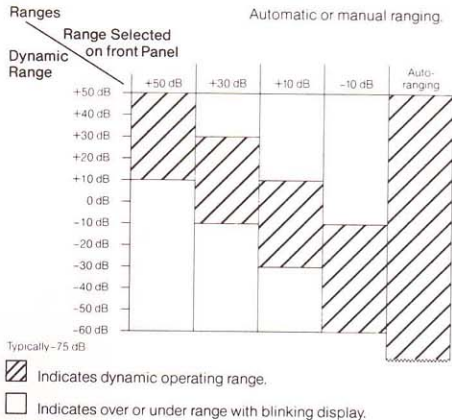

Accuracy —

| | 20 Hz | 2 kHz | 10 kHz | 20 kHz |
|------------------|---------|---------|-------------------|--------|
| +50 dB to -50 dB | ±0.5 dB | | | |
| -50 dB to -60 dB | ±0.5 dB | ±1.5 dB | Typically ±2.5 dB | |

*From 0°C to 18°C and 28°C to 50°C, add 0.6 dB to above accuracy specifications. For example, at 0°C the accuracy in the +50 dB to -50 dB range from 20 Hz to 20 kHz would be ± 1.1 dB.

Noise Level — Typically -75 dB.

Maximum Resolution — 0.1 dB.

Response Time — ≤1 s within a range, ≤1.5 s for each range change in autoranging mode.

Input Impedance — 10 MΩ paralleled by <100 pF.

Maximum Input Voltage — 500 V RMS, not to exceed 1000 V peak.

Crest Factor — 4 at full scale (≤2 above 40 dB).

RESISTANCE

Ranges — 200 Ω, 2 kΩ, 20 kΩ, 200 kΩ, 2000 kΩ, and 20 MΩ. Automatic or manual ranging.

Accuracy — 6 months or 1000 hours. 18°C to 28°C:

| | |
|-------------------------|--|
| 200 Ω to 2000 kΩ Ranges | ±[0.5% of reading +0.05% of full scale (1 count) +0.2 Ω] |
| 20 MΩ Range | ±[1% of reading +0.05% of full scale (1 count)] |

0°C to 18°C and 28°C to 50°C:

| | |
|-------------------------|--|
| 200 Ω to 2000 kΩ Ranges | ±[0.8% of reading +0.1% of full scale (2 counts) +0.2 Ω] |
| 20 MΩ Range | ±[1.3% of reading +0.1% of full scale (2 counts)] |

Response Time — ≤1 s within a range, ≤1.5 s for each range change in autoranging mode.

Maximum Input Volts — 130 V dc or ac RMS indefinitely, 230 V dc or ac RMS for 30 minutes maximum.

HI-LO Ohms Operation — A low voltage is user-selectable for making in-circuit ohms measurements without turning on silicon diode and transistor junctions. A high voltage is also available for testing junctions for forward and reverse resistance.

Maximum Resolution — 0.1 Ω.

Maximum Open-Circuit Voltage Developed — ≈14 V.

DC AND TRUE RMS AC CURRENT

Ranges — 200 μA, 2 mA, 20 mA, 200 mA, and 2000 mA. Manual ranging only.

Accuracy —

Dc Current Only:

18°C to 28°C: ± [0.2% of reading +0.05% of full scale (1 count)].

0°C to 18°C and 28°C to 50°C: ± [0.3% of reading +0.1% of full scale (2 counts)].

Ac Current Only (from 40 Hz to 10 kHz) Usable to 20 kHz.

18°C to 28°C: ± [0.6% of reading +0.3% of full scale (6 counts)].

0°C to 18°C and 28°C to 50°C: ± (0.7% of reading +0.5% of full scale (10 counts)).

Input Resistance —

| Range | Approx Resistance |
|---------|-------------------|
| 200 μA | 1 kΩ |
| 2 mA | 100 Ω |
| 20 mA | 10.2 Ω |
| 200 mA | 1.2 Ω |
| 2000 mA | 0.4 Ω |

Response Time — ≤1 s.

Maximum Open Circuit Input Voltage (mA to LOW) — 250 V peak, fused with 2 A fast blow.

Maximum Floating Voltage — 1000 V peak.

Maximum Resolution — 0.1 μA.

TEMPERATURE

Range — -55°C to +200°C.

Resolution — 0.1°C.

Accuracy — +18°C to +28°C ambient temperature*

Temperature to be Measured

| | -55°C | +150°C | +200°C |
|---|--------|--------|--------|
| P6601 Probe and DM 502A calibrated as a pair | ±2.5°C | | ±3.5°C |
| P6601 and instrument not calibrated as a pair | ±4.5°C | | ±5.5°C |

*For 0°C to +18°C and 28°C to 50°C ambient temperatures, add ±1.5°C to accuracy specifications.

OTHER CHARACTERISTICS

Overrange Indication — Blinking display (except 1000 V dc and 500 V ac).

Measurement Rate — 3 per second.

Power Consumption — ≈8 watts.

Inputs — Maximum input voltage is 1000 V. The front panel volts/Ω, or LOW, or mA terminal can be floated 1000 V peak max above ground, the rear input 200 V peak. For the rear input, ac volts, ohms and maximum input specifications are derated.

INCLUDED ACCESSORIES

One pair test leads 003-0120-00, One P6601 Temperature Probe 010-6601-01.

ORDERING INFORMATION

| | |
|--|-----------|
| DM 502A | \$550 |
| Option 02 (Deletes temperature probe and capability) | Sub \$125 |



The P6601 Probe is a temperature measuring device designed to operate with the DM 502A and DM 501A Digital Multimeters. The temperature sensing element consists of a thin-film platinum resistor on the tip of the probe. Measurements are made by touching the sensing element to the surface whose temperature is in question. The thermal signal is transmitted to the associated digital multimeter through a two-conductor cable.

The thermal time constant on the P6601 Probe is 0.5 s ±0.2 s. The P6601 is totally immersible except in liquids that are not compatible with Dow Corning 308 molding compound, BeO, silicone rubber, or epoxy adhesives. The sensor and tip are limited to a max of 240°C, and cable is limited to a max of 140°C.

Order P6601 Temperature Probe
010-6601-01 \$180

OPTIONAL ACCESSORIES

The following accessories may be ordered as options for use with any of the three TM 500 Digital Multimeters.

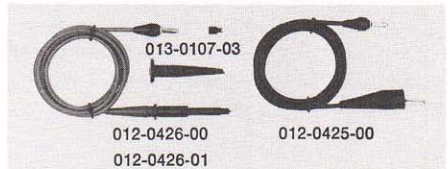

| | |
|--|---------|
| Test Lead, Black, 4 ft 012-0425-00 | \$10.25 |
| Test Lead, Red, 4 ft 012-0426-00 | \$15.50 |
| Test Lead, Black, 4 ft 012-0426-01 | \$15.50 |
| Test Lead Set of 012-0425-00, 012-0426-00, and 013-0107-03, 012-0427-00 | \$29 |
| High Voltage Probe to 40 kV (complete information page 300) Order 010-0277-00 | \$115 |
| P6420 RF Probe, 2 m Cable included (complete information page 327) Order 010-6420-03 | \$120 |
| Female BNC to dual banana adapter | |
| Order 103-0090-00 | \$7.50 |

ENVIRONMENTAL SPECIFICATIONS

The following environmental specs are common to all three digital multimeters.

Temperature — Operating in mainframe: 0°C to 50°C. Nonoperating: -55°C to +75°C. MIL-T-28800B Class 5.

Humidity — 95% to 100% for 5 days (derated above 25°C). MIL-T-28800B, Class 5.

Altitude — Operating in mainframe: to 15,000 ft (4.6 km). Nonoperating: To 50,000 ft (15 km), MIL-T-28800B, Class 3.

Vibration — In TM 515 Mainframe: 0.38 mm (0.015 in) displacement 1 to 55 Hz sinewave for 75 minutes MIL-T-28800B, Class 5. In TM 501, TM 503, TM 504, or TM 505 mainframe: 0.26 mm (0.010 in) displacement, 10-55 Hz sinewave. 75 minutes total.

Without mainframe: MIL-T-28800B, Class 3: 0.060 in 5-10 Hz, 0.040 in 5-25 Hz, 0.020 in 25-55 Hz.

Shock — Operating in TM 515 Mainframe: 30 g's, 1/2 sine, 11 ms duration, 18 shocks, MIL-T-28800B, Class 5. Operating in TM 501, TM 503, TM 504, or TM 506 mainframe: 20 g's 1/2 sine, 11 ms duration, 18 shocks. Without mainframe: MIL-T-28800B, Class 3; 30 g's, 1/2 sine, 11 ms duration, 18 shocks.

Bench Handling — Drop from Operating 45° or 4 in or equilibrium, whichever occurs first. MIL-T-28800B, Class 3.

Electromagnetic Compatibility — Operating in mainframe 30 Hz to 1 GHz: MIL-T-28800B, Class 3.

Electrical Discharge — Operating in mainframe 20 kV max. No MIL-T-28800B equivalent. Charge applied to each protruding area of the front panel except input terminals.

Transportation — Vibration: 25 mm (1 in) at 270 rpm for 1 hour without mainframe; National Safe Transit Association Preshipment Test. Package Drop: 10 drops from 91 cm (3 ft) without mainframe.

Tektronix offers maintenance training classes on the TM 500 Calibration Systems Package and a new multimedia training package on Digital Counter and Meter Concepts. For TM 5000 training and other training information, contact your local Sales Office or request a copy of the Tektronix Customer Training Catalog.

DM 501A

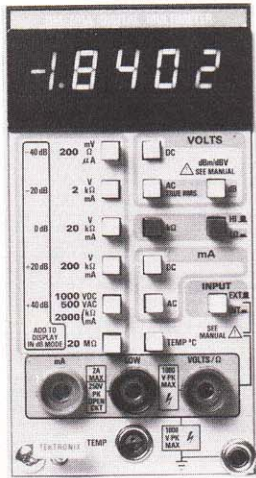

Digital Multimeter

DM 501A

0.05% dc Voltage Accuracy

Seven Functions

dB

4 1/2 Digits

True RMS

The DM 501A Digital Multimeter measures dc and ac voltage, dc and ac current, resistance, dB and temperature. The DM 501A gives 4 1/2 digits of readout resolution. All with 0.05% accuracy and true RMS capability. True RMS allows accurate measurement of distorted wave forms. DB is useful when making critical audio and communication measurements. Fast accurate temperature measurements to 240°C come from the TEKTRONIX P6601 platinum film temperature sensing probe. The P6601 reaches 90% of final reading in 1.5 seconds.

DC VOLTS

Ranges — 200 mV, 2 V, 20 V, 200 V, and 1000 V.
Accuracy — 18°C to 28°C, 6 months or 1000 hours.

| | |
|---------------------|--|
| 200 mV Range | ± [0.05% of reading + 0.015% of full scale (3 counts)] |
| 2 V to 200 V Ranges | ± [0.05% of reading + 0.01% of full scale (2 counts)] |
| 1000 V Range | ± [0.05% of reading + 0.02% of full scale (2 counts)] |

0°C to 18°C and 28°C to 50°C:

| | |
|------------------------|---|
| 200 mV to 200 V Ranges | ± [0.1% of reading + 0.025% of full scale (5 counts)] |
| 1000 V Range | ± [0.1% of reading ± 0.05% of full scale (5 counts)] |

Common-Mode Rejection Ratio — ≥ 100 dB at dc, ≥ 80 dB at 50 Hz and 80 Hz with 1 kΩ imbalance.

Normal-Mode Rejection Ratio — ≥ 60 dB at 50 Hz or 60 Hz ± 0.2 Hz.

Maximum Resolution — 10 μV.

Step Response Time — ≥ 1 second.

Input Resistance — 10 MΩ.

Maximum Input Voltage — 1000 V peak.

TRUE RMS AC VOLTS

Input signal must be between 5% and 100% of full scale.

Ranges — 200 mV, 2 V, 20 V, 200 V, and 500 V (accoupled).
Accuracy — 18°C to 28°C, 6 months or 1000 hours.

| | 20 Hz | 40 Hz | 10 kHz | 20 kHz |
|------------------------|---|---|---|---|
| 200 mV to 200 V Ranges | ± [1% of reading + 0.05% of full scale (10 counts)] | ± [0.6% of reading + 0.05% of full scale (10 counts)] | ± [1% of reading + 0.05% of full scale (10 counts)] | ± [1% of reading + 0.05% of full scale (10 counts)] |
| 500 V Range | ± [1% of reading + 0.2% of full scale (10 counts)] | ± [0.6% of reading + 0.2% of full scale (10 counts)] | ± [1% of reading + 0.2% of full scale (10 counts)] | ± [1% of reading + 0.2% of full scale (10 counts)] |

0°C to 18°C and 28°C to 50°C:

| | 20 Hz | 40 Hz | 10 kHz | 20 kHz |
|------------------------|--|--|--|--|
| 200 mV to 200 V Ranges | ± [1.3% of reading + 0.075% of full scale (15 counts)] | ± [0.8% of reading + 0.075% of full scale (15 counts)] | ± [1.3% of reading + 0.075% of full scale (15 counts)] | ± [1.3% of reading + 0.075% of full scale (15 counts)] |
| 500 V Range | ± [1.3% of reading + 0.3% of full scale (15 counts)] | ± [0.8% of reading + 0.3% of full scale (15 counts)] | ± [1.3% of reading + 0.3% of full scale (15 counts)] | ± [1.3% of reading + 0.3% of full scale (15 counts)] |

Common-Mode Rejection Ratio — ≥ 60 dB at 50 Hz to 60 Hz with 1 kΩ imbalance.

Maximum Resolution — 10 μV.

Response Time — < 2 seconds.

Input Impedance — 10 MΩ paralleled by 160 pF.

Maximum Input Voltage — 500 V ac RMS, 600 V dc, not to exceed 1000 V peak.

Crest Factor — 4 at full scale.

dB (TRUE RMS)

Zero dB Reference — 1 mW in 600 Ω (0.775 V) (dBm) Internal jumper change for zero dB reference of 1.0000 V (dBV).

Accuracy — 18°C to 28°C*

| | 20 Hz | 2 kHz | 10 kHz | 20 kHz |
|------------------|----------|----------|--------------------|--------|
| +20 dB to -15 dB | ± 0.5 dB | | | |
| -15 dB to -20 dB | ± 0.5 dB | ± 1.5 dB | Typically ± 2.5 dB | |

*From 0°C to 18°C and 28°C to 50°C, add 0.6 dB to above accuracy specifications.

Maximum Resolution — 0.1 dB.

Response Time — < 2 seconds.

Input Impedance — 10 MΩ paralleled by < 160 pF.

Maximum Input Voltage — 500 V RMS, not to exceed 1000 V peak. Equivalent to +54 dBV or +56.2 dBm.

Crest Factor — 4 at full scale.

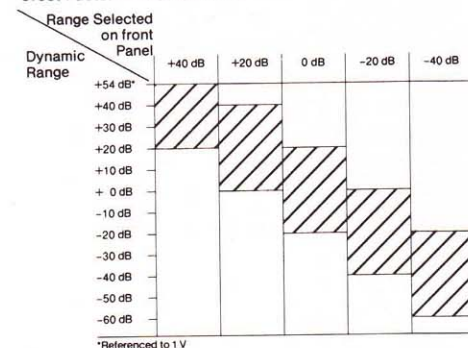

☐ indicates dynamic operating range

▨ indicates out of range with blinking display

To obtain the correct dB reading, algebraically add the range selected to the display reading ("dynamic range" should be ± 20 dB from range reflected on front panel except +54 dB).

RESISTANCE

Response Time — < 2 sec in 200 Ω to 2000 kΩ ranges; < 10 sec in 20 MΩ range.

Maximum Input Volts — 250 V peak.

Maximum Resolution — 10 mΩ.

HI-LO OHM Operation — A low voltage is user-selectable for making in-circuit ohms measurements without turning on silicon diode and transistor junctions. A high voltage is also available for testing junctions for forward and reverse resistance.

Maximum Open-Circuit Voltage Developed — < 6 V.

Ranges — 200 Ω, 2 kΩ, 20 kΩ, 200 kΩ, 2000 kΩ, and 20 MΩ.

Accuracy — 18°C to 28°C, 6 months or 1000 hours.

| 200 Ω Range | LO Ω | ± [0.15% of reading + 0.015% of full scale (3 counts)] |
|------------------------|-----------|--|
| 2 kΩ to 2000 kΩ Ranges | HI Ω | ± [0.15% of reading + 0.015% of full scale (3 counts)] |
| 2 kΩ to 200 kΩ Ranges | LO Ω | ± [0.15% of reading + 0.015% of full scale (3 counts)] |
| 2000 kΩ Range | LO Ω | ± [0.3% of reading + 0.015% of full scale (3 counts)] |
| 20 MΩ Range | HI Ω only | ± [0.5% of reading + 0.015% of full scale (3 counts)] |

0°C to 18°C and 28°C to 50°C:

| 200 Ω Range | LO Ω | ± [0.3% of reading + 0.025% of full scale (5 counts)] |
|--------------------------------|------|---|
| 2 kΩ to 2000 kΩ Ranges | HI Ω | ± [0.3% of reading + 0.025% of full scale (5 counts)] |
| 2 kΩ to 200 kΩ Ranges | LO Ω | ± [0.3% of reading + 0.025% of full scale (5 counts)] |
| 20 MΩ Range LO Ω 2000 kΩ Range | HI Ω | ± [1.2% of reading + 0.025% of full scale (5 counts)] |

DC AND TRUE RMS AC CURRENT

Ranges — 200 μA, 2 mA, 20 mA, 200 mA, and 2000 mA.

Accuracy — 6 months or 1000 hours.

Dc Current only:

18°C to 28°C — ± [0.2% of reading = 0.015% of full scale (3 counts)].

0°C to 18°C and 28°C — ± [0.3% of reading = 0.025% of full scale (5 counts)].

Ac Current only: (from 20 Hz to 10 kHz):

Input signal must be between 5% and 100% of full scale.

18°C to 28°C — ± [0.6% of reading + 0.05% of full scale (10 counts)].

0°C to 18°C and 28°C to 50°C — ± 0.7% of reading + 0.075% of full scale (15 counts)-]. Usable to 20 kHz.

Response Time — < 1 sec dc current, < 2 sec ac current.

Input Impedance —

| Range | Approx. Resistance |
|---------|--------------------|
| 200 μA | 1.0 kΩ |
| 2 mA | 100 Ω |
| 20 mA | 10.2 Ω |
| 200 mA | 1.2 Ω |
| 2000 mA | 0.4 Ω |

Maximum Open-Circuit Input Voltage (mA to LOW) — 250 V peak, fused with 2 A fast blow.

Maximum Floating Voltage — 1000 V peak.

Maximum Resolution — 10 nA.

TEMPERATURE

Range — -62°C to +240°C.

Resolution — 0.1°C.

Accuracy — 18°C to 28°C ambient temperature.*

Temperature to be measured

-62°C +150°C +240°C

P6601 and DM 501A calibrated as a pair ± 2°C +0°C to -6°C

P6601 and instrument not calibrated as a pair. ± 4°C +2°C to -8°C

*For 0°C to 18°C and 28°C to 50°C ambient temperatures, add 1.5°C to above limit in each direction.

OTHER CHARACTERISTICS

Overrange Indication — Blinking display (except on 1000 V dc and 500 V ac ranges).

Measurement Rate — 3 1/3 per second.

Power Consumption — ≈ 9 watts.

Inputs — Maximum input voltage is 1000 V. The front panel Volts/, or LOW, or mA terminals can be floated to 1000 V peak max. above ground, the rear input only 200 V peak. For the rear input, ac volts, ohms, and maximum input specifications are derated.

INCLUDED ACCESSORIES

One pair of test leads 003-0120-00; one P6601 Temperature Probe 010-6601-01. For environmental specifications and accessories see previous page.

ORDERING INFORMATION

DM 501A Digital Multimeter \$630

Option 02 (deletes P6601 Temperature Probe and temperature measurement capability) Sub \$125

Now, more counter capability than ever before. The 135 MHz DC 5009 and the 350 MHz DC 5010, both fully programmable, IEEE-488 compatible Universal Counter Timers feature Reciprocal Frequency, Auto-Trigger, Probe Compensation, and more. The DC 509 and DC 510 provide all of the performance of the DC 5009 and DC 5010 except IEEE-488 compatibility. And that can be added as a field modification at a later date.

Add the DC 508A, the DC 503A, and the DC 504 and you have a counter selection to satisfy virtually any application.

The DC 508A is a 1.3 GHz communications counter ideal for high frequency applications. The DC 508A, which features an audio frequency resolution multiplier, is particularly applicable to telecommunications, aerospace and two-way communications.

The DC 503A is a 125 MHz Universal Counter/Timer designed for field service and general maintenance applications. The DC 503A is designed to offer a wide choice of performance features at an affordable price.

The DC 504 is an 80 MHz, General Purpose Counter available at an affordable price. The compact size of the DC 504 makes it particularly suitable for field service applications.

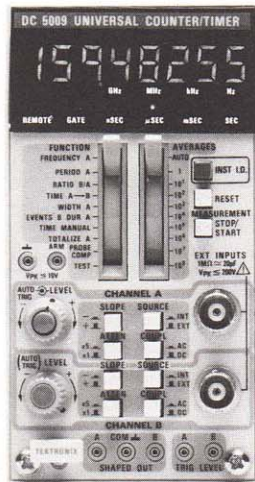

DC 509 UNIVERSAL COUNTER TIMER

DC 5009 PROGRAMMABLE UNIVERSAL COUNTER TIMER

NEW

GPIB IEEE-488

The DC 5009 is designed to comply with IEEE Standard 488-1978 and with Tektronix *Codes and Formats* Standard. The DC 509 is identical to the DC 5009 except that it is not GPIB compatible.

DIGITAL COUNTERS—SELECTION GUIDE

| | DC 503A | DC 504 | DC 508A | DC 509/DC 5009 | DC 510/DC 5010 |
|---------------------------------------|--|----------------|---|---|--|
| Number of digits | 8 | 5 | 9 | 8 | 9 |
| Frequency Range | 125 MHz | 80 MHz | 1.3 GHz | 135 MHz | 350 MHz |
| Ratio Architecture | NO | NO | NO | YES | YES |
| Period | YES, plus Averaging | YES | NO | YES, plus Averaging | YES, plus Averaging |
| Width Averaging (single input) | YES | NO | NO | YES | YES |
| Time Interval Avg. | YES | NO | NO | YES | YES |
| Auto-Trigger | NO | NO | NO | YES | YES |
| Gated Events Avg. | A during B | NO | NO | B during A | B during A |
| Ratio Averaging | YES | NO | NO | YES | YES |
| Other | Option 01, trigger level & shaped outputs, time manual, totalize | Option 01, rpm | Option 01, trigger level & resolution multiplier, 1 M Ω /50 Ω input | Option 01, trigger level & shaped outputs, self-test, phase modulated clock, probe compensation IEEE 488 (DC 5009) fully programmable (DC 5009) | Option 01, trigger level & shaped outputs, self-test, phase modulated clock, probe compensation 1 picosecond resolution (Time A-B) IEEE 488 (DC 5010) fully programmable (DC 5010) |
| Price | \$930 | \$600 | \$1500 | \$1700/2200 | \$3100/3600 |

Fully programmable

Frequency and Period to 135 MHz

Eight measurement functions:

- Reciprocal Frequency (8 digits in $\leq 1s$)
- Period and Period Average
- Width and Width Average
- Time A \rightarrow B and Time A \rightarrow B Average
- Events B During A and Events B During A Average
- Totalize
- Time Manual
- Ratio B/A and Ratio B/A Average

Duty cycle independent Auto-Trigger from 20 Hz to 100 MHz in 2.5 seconds for both channels

Trigger level and shaped outputs for ease of triggering

10 ns single-shot resolution in all timing modes

Designed for serviceability including power-up self test and signature analysis

Auto or Selected Averaging from 1 to 10⁸ in all modes

Probe compensation mode for true probe compatibility

Arming for added measurement capability with complex waveforms

The DC 509/DC 5009 Universal Counter/Timer makes frequency and period measurements to 135 MHz using the powerful reciprocal counting technique. This method provides high resolution of low frequency signals much faster than conventional counting techniques. Signals to be counted or timed can be applied to channels A or B via front panel BNC connectors or rear interface connections.

The DC 5009 is designed to operate in TM 5000 Mainframes. The DC 509 will operate in both the TM 500 and the TM 5000 Series. The DC 509 offers a broad range of versatile features including Auto-Trigger, Auto-Averaging, and Probe Compensation.

Auto-Trigger, at the push of a button, senses the applied signal and sets both trigger levels to the optimum trigger points. Channel A and B trigger levels can be monitored at front panel jacks or via rear interface connections. Available are buffered voltages corresponding to the trigger levels set by the front panel controls or the Auto-Trigger. Also available over the IEEE-488 bus are the minimum and maximum peaks signal voltage values as well as the mid point values for both channels. Trigger level outputs are essential for accurate time interval measurements, especially when the rise and fall time of the signal accounts

for a sizable portion of the time interval to be measured. The outputs of the signal shaping circuits can be monitored, also. These outputs are useful in setting the trigger points on complex waveforms.

The DC 509/DC 5009 provides ten measurement functions, and an averaging feature allows measurements to be averaged from 1 to 10⁸ times with usable resolution to 5 picoseconds. A pseudo-random, phase-modulated time base, standard in the DC 509/DC 5009, provides increased accuracy by eliminating clock-synchronous errors in the time interval and width averaging modes.

The DC 509/DC 5009, a microprocessor-based instrument, executes an extensive self-test routine when powered up. A unique feature-Probe Compensation-permits quick and accurate compensation of signal probes. An arming input allows measurements of selected events within complex waveforms.

The English-like programming language makes GPIB control of the DC 5009 easy. The GPIB commands allow full access to all DC 5009 controls and features.

The DC 509/DC 5009 can be equipped with an optional oven-controlled, 10 MHz crystal oscillator (Option 01) to obtain a more accurate, highly stable time base.

A conversion kit is available to owners of DC 509's who desire IEEE-488 capabilities. This option is a field modification kit which easily converts a DC 509 to DC 5009.

DC 509/5009 CHARACTERISTICS

Display — Eight-digit LED display, automatic decimal point positioning, LED indicators for units, and measurement gate. Overflow is indicated by a blinking display.

CHANNEL A AND B INPUT CHARACTERISTICS

Frequency Range — 0 to 135 MHz dc coupled, 10 Hz to 135 MHz ac coupled.

Sensitivity — 20 mV RMS sinewave to 100 MHz, 40 mV RMS sinewave to 135 MHz, 115 mV p-p at min. pulse width of 3 ns.

Attenuation — Selectable 1X, 5X.

Impedance — 1 M Ω paralleled by ≤ 30 pF.

Dynamic Range — ± 3 V p-p x Attenuation, tr ≥ 5 ns.

Trigger Level —

DC 509: Adjustable ± 3.2 V x Attenuation

DC 5009: (+3.200 to -3.175) x Attenuation, 25 mV resolution.

Auto-Trigger Frequency Range — 20 Hz to 100 MHz ($V_{in} \geq 125$ mV p-p).

Independent Controls — Slope +/-, Atten. 1X/5X, Coupl. AC/DC, Source INT/EXT.

Max. Input Voltage —

1X: 200 V pk; 400 V p-p from dc to 50 kHz, derate to 15 V p-p at 135 MHz.

5X: 200 V pk; 400 V p-p from dc to 5 MHz, derate to 25 V p-p at 135 MHz.

Shaped Out — Shaped replica of signal being measured, aids proper triggering on complex waveforms. Amplitude 0 to $\geq +0.3$ V from 50 Ω .

Trigger Level Out — A dc level corresponding to the actual trigger level. Accuracy within ± 10 mV of internal trigger level.

Arming Input — Permits measurements of complex waveforms. A TTL high allows averaging of selected events within a measurement.

FREQUENCY A

Range — 100 μ Hz to 135 MHz.

Resolution —

$$\pm \text{LSD} \pm 1.4 \times \frac{\text{Trigger Jitter Error}}{N} \times (\text{Frequency A})^2$$

Accuracy —
 Resolution \pm (Time Base Error x Frequency A.)

PERIOD A

Range — 7.40 ns to 3.05 hours.

Resolution —

$$\pm \text{LSD} \pm 1.4 \times \frac{\text{Trigger Jitter Error}}{N}$$

Accuracy — Resolution \pm (Time Base Error x Period A.)

RATIO B/A

Range — 10^{-7} to 10^8 (Frequency Range: Ch A to 135 MHz; Ch B to 125 MHz.)

Resolution —

$$\pm \text{LSD} \pm 1.4 \times \frac{\text{B Trigger Jitter Error} \times \text{Frequency B}}{N}$$

Accuracy — Same as Resolution.

TIME A \rightarrow B

Range — 15 ns to 3.05 hours.

Minimum Dead Time — 15 ns (stop to start).

Resolution —

$$\pm \text{LSD} + \frac{1}{\sqrt{N}} \times (\pm \text{Ch A Trigger Jitter Error} \pm \text{Ch B Trigger Jitter Error})$$

Accuracy — Resolution \pm (Time Base Error x Time A \rightarrow B) + (Ch B Slew Rate Error - Ch A Slew Rate Error) \pm Channel Delay Mismatch.

Channel Delay Mismatch — < 2 ns between front panel inputs and < 3 ns between rear interface inputs.

EVENTS B DURING A

Range — 10^{-7} to 10^8 .

Maximum B Frequency — 125 MHz.

Minimum A Pulse Width — 15 ns.

Minimum Time Between A Pulses — 15 ns.

Minimum Time Between "A" Start Edge and First "B" Event — 15 ns.

Resolution —

$$\pm \text{LSD} + \frac{\text{Frequency B}}{\sqrt{N}} (\pm \text{Trigger Jitter Error Ch A start edge} \pm \text{Trigger Jitter Error Ch A stop edge.})$$

Accuracy — Resolution + FREQ B (Stop Slew Rate Error - Start Slew Rate Error).

WIDTH A

Range — 15 ns to 3.05 hours.

Minimum Dead Time Between Pulses — 15 ns.

Resolution —

$$\pm \text{LSD} + \frac{1}{\sqrt{N}} (\pm \text{Start Trigger Jitter Error} \pm \text{Stop Trigger Jitter Error.})$$

Accuracy — Resolution \pm (Time Base Error x Width) + (Stop Slew Rate Error - Start Slew Rate Error) ± 5 ns.

TIME MANUAL

Range — 0 to 3.05 hours.

Resolution — \pm LSD. (100 ms.)

Accuracy — \pm Resolution \pm (Time Base Error x TIME).

TOTALIZE A

Range — 0 to 1.09×10^{12} counts.

Repetition Rate — 0 to 135 MHz.

PROBE COMP

Display — 1 or 0 for each channel.

Accuracy —

$$\frac{\text{Probe Atten.} \times 50 \text{ mV} \times 100 (\%)}{V_{in} \text{ at Probe}}$$
 (2.5% nominal for X5 probe with 10 V p-p at the probe).

RESOLUTION AND ACCURACY DEFINITIONS

Trigger Jitter Error (seconds RMS) —

$$\frac{\sqrt{(en1)^2 + (en2)^2} \text{ (Volts RMS)}}{\text{Input Slew Rate at trigger point (V/s)}}$$
 where en1 = 120 μ V RMS typical counter input noise
 en2 = RMS Noise Voltage of input signal at trigger point measured with 150 MHz bandwidth.

Slew Rate Error (seconds) —

$$\frac{\text{Input Hysteresis/2}}{\text{Input Slew Rate at trigger point (V/S)}}$$

Note: Input hysteresis is typically 20 mV p-p.

N = Number of Averages

The minimum number of averages is selected by the AVERAGES control in decade steps from 1 to 10⁸. At Channel A repetition rates above ≈ 250 Hz, the number of averages will be:

$$N = [\text{Frequency A (Hz)} \times 4 \text{ ms}] + \text{AVERAGES.}$$

In the AUTO mode, the counter measures with a fixed measurement time of about 300 ms.

$$N (\text{AUTO}) \approx \text{Frequency A (Hz)} \times 0.3 \text{ seconds.}$$

N is always ≥ 1 .

Time Base Error — The sum of all errors specified for the time base used.

STANDARD TIME BASE

Crystal Frequency — 10 MHz.

Temp. Stability — $\pm 5 \times 10^{-6}$, 0°C to 50°C.

Aging Rate = 1×10^{-6} per year.

Setability — Adjustable to within $\pm 1 \times 10^{-7}$ or better.

HIGH STABILITY TIME BASE (OPTION 01)

Crystal Frequency — 10 MHz.

Temperature Stability — $\pm 2 \times 10^{-7}$ after warm-up, 0°C to 50°C.

Warm-up Time — Within 2×10^{-7} of final frequency in less than 10 minutes when cold-started at 25°C.

Aging Rate — 1×10^{-8} /day at time of shipment, 4×10^{-8} /week after 30 days of continuous operation, 1×10^{-8} /year after 60 days of continuous operation.

Setability — Adjustable to within 2×10^{-8} .

REAR INTERFACE

Inputs — Channel A and B input to 50 MHz (50 Ω impedance, max input 3.6 V pk); arming; reset; external time base (1, 5, or 10 MHz).

Outputs — Channel A and B shaped outputs; Channel A and B trigger level outputs; 10 MHz clock; gate out.

OTHER CHARACTERISTICS

Power Consumption —

DC 509: ≈ 11.1 W \approx (15 W with Option 01)

DC 5009: ≈ 12 W \approx (15 W with Option 01)

GPIB Data Output Rate (DC 5009 only) — ≈ 10 readings/sec. max.

GPIB Commands (DC 5009 only) — Addressable by English-like ASCII GPIB commands.

INCLUDED ACCESSORIES

Tip Jack to BNC Service Kit, 175-3765-01.

RECOMMENDED PROBES

P6125 5X Passive Probe 010-6125-01

ORDERING INFORMATION

DC 509 \$1700

DC 5009 \$2200

Option 01 High Stability Time Base Add \$275

Field GPIB Kit for DC 509 040-0957-00 \$500

NEW

DC 510 UNIVERSAL COUNTER/TIMER

NEW

DC 5010 PROGRAMMABLE UNIVERSAL COUNTER/TIMER

**GPIB
IEEE-488**

The DC 5010 is designed to comply with IEEE Standard 488-1978 and with Tektronix *Codes and Formats* Standard. The DC 510 is identical to the DC 5010 except that it is not GPIB compatible.

Fully Programmable (DC 5010)

350 MHz both A and B Channels

13 Measurement Functions:

Ratio Architecture (Provides Benefits of Reciprocal Frequency: Nine Digits in <1/3 Second.

Period and Period Average

Width and Width Average

Time A → B and Time A → B Average

Events B During A and Events B During A Average

Totalize (A, A+B, A-B)

Time Manual

Ratio B/A and Ratio B/A Average

Rise Time A/Fall Time A (with averaging)

Duty Cycle Independent Auto-Trigger from 20 Hz to 350 MHz in <2.5 sec.

DVM Mode for Displaying Trigger Level Setting

Shaped A and B Channel Outputs

3.125 ns Single-shot Resolution

Selected Averaging from 1 to 10⁹ or Auto

Hysteresis Compensation

Probe Compensation Mode for Probe Compatibility

Arming for Added Measurement Capability with Complex Waveforms

Designed for Serviceability with Powerful Self Test and Signature Analysis

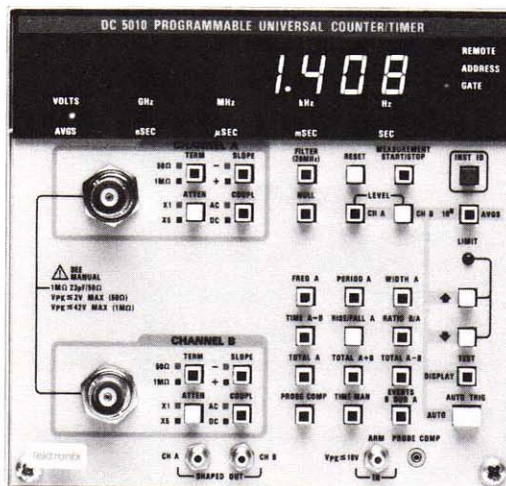

The DC 510/DC 5010 Universal Counter /Timer features reciprocal frequency, period, ratio, and events B during A measurements to 350 MHz. The powerful reciprocal technique provides high resolution of low frequency signals much faster than conventional counting techniques. For timing measurements, time interval and width feature 3.125 ns single-shot resolution, as do the new risetime and falltime functions. For all of the above measurements, identical A and B channels and averaging provide increased accuracy. The averaging feature allows measurements to be averaged from 1 to 10⁹ times with usable time interval resolution to 1 picosecond. A pseudo-random, phase modulated time base in the DC 510/DC 5010, provides increased accuracy by eliminating clock synchronous errors in the time interval and width averaging modes. Also included is a time manual mode, as well as three 350 MHz totalize modes: A, A+B, and A-B.

The DC 510/DC 5010 also has an auto-trigger feature for ease of set-up. Auto trigger, at the push of a button senses the applied signal and sets both trigger levels to the optimum trigger points. In the DC 5010, trigger levels are available over the bus, as are the minimum and maximum peak signal voltage values. In both the DC 510 and DC 5010, the trigger voltage setting can be displayed. Such trigger level information is essential for accurate time interval measurements, especially when the rise and fall time of the signal accounts for a sizable portion of the time interval to be measured. Hysteresis compensation is automatic in the DC 510/DC 5010. The outputs of the signal shaping circuits can also be monitored. These outputs are useful for setting the trigger points on complex waveforms.

The DC 510/DC 5010, micro-processor based instruments execute an extensive self test routine when powered up. The test modes and signature analysis contribute to a reduced life cycle cost of ownership. A unique feature-Probe Compensation-permits quick and accurate compensation of signal probes. An arming input allows measurement of selected events within complex waveforms. The DC 510/DC 5010 use proprietary amplifiers and Schmitt trigger circuitry to provide flat sensitivity and low distortion signal acquisition.

The DC 5010 is an IEEE-488 compatible, fully programmable version of the DC 510 and allows every manually selectable function or mode to be operated over the IEEE-488 bus, including all input conditioning controls. The English like programming commands makes bus control of the DC 5010 easy. The GPIB bus commands allow full access to all DC 5010 controls and features.

The DC 510/DC 5010 can be equipped with an optional oven-controlled, 10 MHz crystal oscillator (Option 01) to obtain an even more accurate highly stable time base.

A conversion kit is available to owners of DC 510's who desire IEEE-488 capabilities. The field modification kit easily converts a DC 510 to a DC 5010.

The DC 510 will work in either 500 or 5000 Series Mainframes. The DC 5010 will work only in the 5000 Series.

DC 510/DC 5010 CHARACTERISTICS

Display — Nine-digit LED display, automatic decimal point positioning. LED indicators for units, and measurement gate, and bus conditions. Overflow is indicated by a blinking display.

CHANNEL A AND B INPUT CHARACTERISTICS

Frequency Range —

50 Ω Termination: 0 to 350 MHz dc coupled. 100 kHz to 350 MHz ac coupled.

1 MΩ Termination: 0 to 300 MHz dc coupled. 16 Hz to 300 MHz ac coupled.

Sensitivity —

50 Ω Termination dc: 25 mV RMS sinewave to 350 MHz. 70 mV p-p pulse.

1 MΩ Termination ac: 25 mV RMS to 200 MHz, 42 mV RMS to 300 MHz, dc coupled. 25 mV RMS, 16 Hz to 200 MHz, 42 mV RMS to 300 MHz, ac coupled.

Attenuation — Selectable 1X, 5X.
Impedance — 1 M Ω paralleled by 23 pF \pm 2 pF or 50 Ω .
Trigger Level Range — +2 V to -2 V (X1), +10 V to -10 V (X5).
Dynamic Range — 4 V p-p x Attenuation.
Auto-Trigger Frequency Range — 10 Hz to 350 MHz.
Independent Controls — Slope +/-, Atten. 1X/5X, Coupl. ac/dc, Imped. 1 M Ω /50.

Maximum Input Voltage — 1 M Ω input impedance -
1X: \pm 42 V (dc + peak ac) to 200 kHz; \pm 2 V (dc + peak ac) to 300 MHz.
5X: \pm 42 V (dc + peak ac) to 1 MHz; \pm 10 V (dc + peak ac) to 300 MHz

In 50 Ω input impedance, signals $>$ \pm 2 V X attenuator will cause input protection circuitry to switch input to 1 M Ω .

Shaped Out — Shaped replica of signal being measured, aids proper triggering on complex waveforms (\geq 200 mV typically \geq 100 into 50 Ω load).

Arming Input — Permits measurements of complex waveforms. A TTL high allows averaging of selected events within a measurement.

FREQUENCY A

Range — 36 μ Hz to 350 MHz.
Resolution —

$$\pm \text{LSD} \pm 1.4 \times \frac{\text{A Trigger Jitter Error}}{\text{N}} \times (\text{Frequency A})^2$$

Accuracy — Resolution \pm (Time Base Error x Frequency A.)

PERIOD A

Range — 3.125 ns to 7.6 hours.
Resolution —

$$\pm \text{LSD} \pm 1.4 \times \frac{\text{A Trigger Jitter Error}}{\text{N}}$$

Accuracy — Resolution \pm (Time Base Error) x Period A.

RATIO B/A

Range — 10^{-8} to 10^9 (Frequency range 36 μ Hz to 350 MHz)
Resolution —

$$\pm \text{LSD} \pm 1.4 \times \frac{\text{B Trigger Jitter Error X Frequency B}}{\text{N}}$$

Accuracy — Same as Resolution.

TIME A \rightarrow B

Range — 2.0 ns to 7.6 hours.
Resolution —

$$\pm \text{LSD} \pm \frac{1}{\sqrt{\text{N}}} \times (\pm \text{Ch A Trigger Jitter Error} \pm \text{Ch B Trigger Jitter Error})$$

Accuracy —
 Resolution \pm (Time Base Error x Time A \rightarrow B) + (Ch B Slew Rate Error) \pm (Channel Delay Mismatch*).
 *Can be removed with "Null".

Resolution — Best time A \rightarrow B Avg. resolution = \pm 1 psec.
Minimum Dead Time — 12.5 ns (stop to start).
Rep Rate — $<$ 70 MHz.

EVENTS B DURING A

Range — 10^{-8} to 10^9 .
Maximum B Frequency — 350 MHz
Maximum A Frequency — 80 MHz
Minimum A Pulse Width — 4.0 ns (and 8.5 ns min. time between pulses).
Resolution —

$$\pm \text{LSD} \pm \frac{\text{Frequency B}}{\sqrt{\text{N}}} \pm \text{Trigger Jitter Error}$$

 Ch A start edge

$$\pm \text{Trigger Jitter Error Ch A stop edge}.$$

Accuracy — Resolution + Freq. B (Stop Slew Rate Error - Start Slew Rate Error).

WIDTH A

Range — 4 ns to 7.6 hours.
Resolution —

$$\pm \text{LSD} \pm \frac{1}{\sqrt{\text{N}}} (\pm \text{Start Trigger Jitter Error} \pm \text{Stop Trigger Jitter Error}).$$

Accuracy — Resolution \pm (Time Base Error x Width) + (Stop Slew Rate Error - Start Slew Rate Error) \pm 2 ns.
Minimum Time, Start to Stop — \leq 8.5 ns.

TIME MANUAL

Range — 0 to 3.125 x 10^4 s (\approx 8 hours).
Resolution — \pm LSD (100 ms).
Accuracy — \pm Resolution \pm (Time Base Error x TIME).

TOTALIZE A

Range — 0 to 10^9 counts.
Repetition Rate — 0 to 350 MHz.

TOTALIZE A+B

Range — 0 to 10^9 counts (A+B \leq 10^9).
Repetition Rate — 0 to 350 MHz.

TOTALIZE A-B

Range — -1×10^8 to $+1 \times 10^9$ (either A $>$ 10^{12} or B $>$ 10^{12} will cause overflow).
Repetition Rate — 0 to 350 MHz.

RISE/FALL A

Range — 5.0 ns to 10^4 s. (1 M Ω and 50 Ω .)
Repetition Rate — Minimum time between rising (falling) edges is 12.5 ns (80 MHz).
Input amplitude — (1.4 V to 8 V) X Attenuation (50 Ω), (.7 V to 4 V) X Attenuation (1 M Ω).
Resolution —

$$\pm \text{LSD} \pm \frac{1}{\sqrt{\text{N}}} (\pm \text{Start Trigger Jitter Error} \pm \text{Stop Trigger Jitter Error}).$$

Accuracy — Resolution \pm (Time Base Error x RISE/FALL TIME) \pm 2 ns \pm 4 mV x Slew Rate A Error (near 10%) \pm 4 mV Slew Rate A Error (near 90%).

Resolution and Accuracy Definitions —

Trigger Jitter Error (seconds RMS) =

$$\frac{\sqrt{(e_{n1})^2 + (e_{n2})^2} \text{ (Volts RMS)}}{\text{Input slew rate at trigger point (Volts/Sec)}}$$



Where e_{n1} = 140 μ V RMS typical Counter Input noise for 1 M Ω filter on; 240 μ V RMS typical for 1 M Ω filter off and 340 μ V RMS typical for 50 Ω .

e_{n2} = RMS Noise Voltage of input signal at trigger point measured with the appropriate bandwidth.

Slew Rate Error (seconds) —

$$= \frac{\text{*trigger level error (volts)}}{\text{Input slew rate at trigger point (volts/sec)}}$$

*Trigger level error =

| | | |
|--|---|--|
| All functions except Width and Events B | Pos slope | trigger accuracy times ATTN factor |
| Dur A | Neg slope | (trigger accuracy \pm 10 mV) times ATTN factor |
| Width A,  | start edge | trigger accuracy times ATTN factor |
| | stop edge | (trigger accuracy + hyst) times ATTN factor |
|  | start edge | (trigger accuracy + hyst) times ATTN factor |
| | stop edge | trigger accuracy times ATTN factor |
| Events B | Same as Width, except each number is multiplied by (Freq B) | |

Note: Input hysteresis is typically 50 mV p-p x attenuation.
 N = Number of Averages

The minimum number of averages is selected by the AVERAGES button and the \uparrow , \downarrow buttons in decade steps from 1 to 10^9 . At Channel A repetition rates above \approx 250 Hz the actual number of averages will be:

$$\text{N} = \lceil \text{Freq. A (Hz)} \times 4 \text{ ms} \rceil + \text{Averages.}$$

 N = Averages setting (below 250 Hz).

This typically leads to better than expected resolution in the displayed answer for small N with only minimal impact on measurement time. It does mean however that Arming must be used where only N = 1 is desired for signals \geq 250 Hz.

In the AUTO mode the counter measures with a fixed measurement time of about 300 ms (or the time for one event, whichever is greater).

$$\text{N} = \text{Freq. A (Hz)} \times .3 \text{ seconds (N always } \geq 1).$$

Probe Comp Display indicates 1 for over comp, 0 for under comp. Accuracy = (A X 0.300)% . A = Probe Attenuation times counter attenuator setting.

Time Base Error — The sum of all errors specified for the time base used.

STANDARD TIME BASE

Crystal Frequency — 10 MHz.
Temp. Stability — \pm 5 x 10^{-6} , 0 $^\circ$ C to 50 $^\circ$ C.
Aging rate — \leq 1 ppm/year.
Setability — Adjustable to within \pm 5 x 10^{-8} .

HIGH STABILITY TIME BASE (OPTION 01)

Crystal Frequency — 10 MHz.
Temp. Stability — \pm 2 x 10^{-7} after warm-up, 0 $^\circ$ C to 50 $^\circ$ C.
Warm-up Time — Within \pm 2 x 10^{-7} of final frequency in $<$ 10 minutes when cold-started at 25 $^\circ$ C.
Aging Rate — 1 x 10^{-8} /day at time of shipment, -4 x 10^{-8} /week after 30 days of continuous operation, 1 x 10^{-6} /year after 60 days of continuous operation.
Setability — Adjustable to within \pm 2 x 10^{-8} .

REAR INTERFACE

Inputs — Arming; reset; external time base (1.5, or 10 MHz)
Outputs — 1 MHz clock.

OTHER CHARACTERISTICS

Power Consumption —
 DC 510: 15 W \approx (19 W with Option 01).
 DC 5010: 15.5 W \approx (19.5 W with Option 01).
 GPIB Data Output Rate (DC 5010 only) — \approx 10 readings/second maximum.
 GPIB Commands (DC 5010 only) — Addressable by 45 English-like GPIB commands.

INCLUDED ACCESSORIES

One each shaped Output Cable 012-0532-00.

RECOMMENDED PROBE

P6125 5 X Passive Probe 010-6125-01

ORDERING INFORMATION

| | |
|---|-----------|
| DC 510 | \$3100 |
| DC 5010 | \$3600 |
| Option 01 High Stability Time Base | Add \$275 |
| Field GPIB Kit for DC 510 040-1023-00 | 500 |

DC 508A

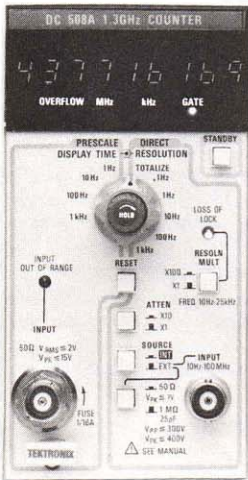

Frequency Counter

DC 508A

Frequency up to 1.3 GHz

Sensitivity to 20 mV RMS Prescale,
15 mV RMS Direct.

X100 Resolution Multiplier to 25 kHz

Input Out-of-Range Light

Nine Digit LED Readout

Front Panel Fuse Protection on
Prescale Input

The DC 508A Counter, designed to operate in TM 500/TM 5000 Series Mainframes, measures frequency from 10 Hz to 1.3 GHz. A nine-digit LED display shows frequency or total events from 0 to 999,999,999. The prescaler input allows it to measure frequency from 100 MHz to 1.3 GHz, and the direct input from 10 Hz to 100 MHz. The decimal point is automatically positioned and leading zeros suppressed. Digit overflow is indicated by a front panel LED. Option 01 includes a high-stability time base, and Option 07 includes Option 01 and an interface for the TR 502 and TR 503 Tracking Generator/Spectrum Analyzer. An audio frequency resolution multiplier multiplies the resolution by 100 from 10 Hz to 25 kHz. This allows resolution of 0.01 Hz in 1 second. Detent position of Display Time knob provides a hold mode.

DISPLAY

Nine-digit LED display, leading zeros blanked, automatic decimal point positioning, LED front panel indicators for gate open, overflow, kHz, and MHz.

DIRECT INPUT

Frequency Range — 10 Hz to 100 MHz.

Sensitivity — 15 mV RMS.

Impedance — Selectable 50 Ω and 1 MΩ paralleled by 25 pF.

Maximum Operating Input Voltage — For 50 Ω is ≤ 7 V peak. For 1 MΩ: 1X attenuation, V peak ≤ 400 V; V p-p ≤ 300 V from 10 Hz to 0.75 MHz, V p-p 225/fMHz V from 0.75 MHz to 22 MHz, V p-p ≤ 10 V above 22 MHz; for a pulse, V peak ≤ 400 V and dV/dt ≤ 5 V/ns. For 1 MΩ, 10X attenuation, V peak ≤ 400 V; V p-p ≤ 300 V from 10 Hz to 1 MHz, V p-p ≤ 300 /fMHz V from 1 MHz to 6 MHz, V p-p ≤ 100 V above 6 MHz.

Attenuation — 1X, 10X.

Resolution (without resolution multiplier) — 0.1 Hz with 10 s gate, 1 Hz with 1 s gate, 10 Hz with 100 ms gate, 100 Hz with 10 ms gate, and 1 kHz with 1 ms gate.

Rear Interface Internal Input Sensitivity — 125 mV RMS to 50 MHz.

Rear Interface Internal Input Impedance — 50 Ω.

Rear Interface Internal Input Maximum Input Voltage — 4 V.

Resolution Multiplier Frequency Range — 10 Hz to 25 kHz.

Resolution Multiplier Multiplication — X100.

Resolution Multiplier Lock Time — ≤ 5 s.

PRESCALE INPUT ($\div 8$)

Frequency Range — 100 MHz to 1.3 GHz.

Sensitivity — 20 mV RMS from ≤ 100 MHz to ≥ 1.1 GHz (-21 dBm) 40 mV RMS (-15 dBm) from 1.1 to 1.3 GHz.

Impedance — 50 Ω.

VSWR — $\leq 2.2:1$.

Maximum Operating Input Voltage — V peak ≤ 15 V, V RMS ≤ 2 V ($+19$ dBm).

Resolution — 1 Hz with 8 s gate, 10 Hz with 800 ms gate, 100 Hz with 80 ms gate, and 1 kHz with 8 ms gate.

Input Protection Voltage — Input fuse opens at ≈ 9 V RMS ($+30$ dBm).

Input Out-of-Range LED — Indicates voltage or frequency too low for error-free counting.

TIME BASE

Frequency — 10 MHz; may also be used with external time bases with TTL levels at 1, 5, and 10 MHz.

Temperature Stability — 0°C to 50°C — $\pm 5 \times 10^{-6}$.

Aging Rate — 1×10^{-6} per year.

OPTION 01 TIME BASE (OVEN OSCILLATOR)

Frequency — 10 MHz.

Temperature Stability, 0°C to 50°C After Warmup — Within 0.2 parts in 10^6 after warmup.

Warmup Time — Within ± 0.2 ppm of final frequency in < 10 minutes when cold-started at 25°C.

Aging Rate — $\leq 1 \times 10^{-8}$ /day at time of shipping, $\leq 4 \times 10^{-8}$ /week after a month of continuous operation, $\leq 1 \times 10^{-6}$ /year after two months of continuous operation.

Setability — $\pm 2 \times 10^{-8}$.

Rear Inputs — Frequency, reset, external clock, start count.

Rear Outputs — BCD, decimal point, time slot zero, scan clock, data good, overflow, reset, gate out.

ACCURACY

The overall DC 508A accuracy is:

$$\text{Accuracy (\% of reading)} = \pm (\text{time base accuracy} + \frac{1}{|\text{total displayed counts}|}) \times 100.$$

Time base accuracy $\leq \pm$ [calibration accuracy + temperature stability + (aging rate \times time since calibration) + short-term stability].

ORDERING INFORMATION

| | |
|---|------------------|
| DC 508A Frequency Counter | \$1500 |
| Option 01 (Time Base) | Add \$275 |
| Option 07 (Includes Option 01 Time Base) for use with TR 502 | Add \$325 |

DC 503A

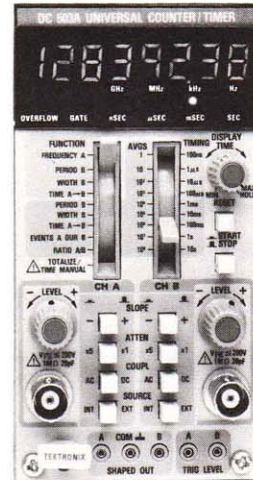

Universal Counter/Timer

DC 503A

125 MHz both A and B channels

Eight measurement functions

Frequency

Period and Period Average

Width and Width Average

Time A→B and Time A→B Average

Events A During B Average

Totalize

Time Manual

Ratio A/B Average

10 ps Resolution in Time Interval
Average with 10^8 Averages

Shaped Outputs for Ease of Triggering

40 MHz Rep Rate in Time Interval Average

Simplified Width Measurement

Designed for True Probe Compatibility

Trigger level Outputs for
Accurate Trigger Setting

The DC 503A offers a broad range of measurement features at an affordable price. The instrument has two input channels, A and B, each with 125 MHz capability. Each channel has separate triggering level, triggering slope, attenuator, and coupling mode controls. Eight measurement functions are available with the DC 503A and an averaging feature allows measurements to be averaged from 1 to 10^8 times. Signals to be counted or timed can be applied to channels A and B via front panel BNC connectors, or through rear interface connections. The DC 503A features an easy access front panel and an LSI based design for increased instrument reliability.

The DC 503A can be equipped with an optional oven-controlled 10 MHz crystal oscillator (Option 01) to obtain a highly stable and precise internal time base. Both the optional oscillator and the standard 10 MHz crystal oscillator provide 100 ns resolution of single-shot time intervals.

DC 503A CHARACTERISTICS

Display — Eight digit LED display, LED indicators for units, gate open, and overflow.

Display Time — ≈0.2 seconds to 5 seconds and hold.

CHANNEL A AND B INPUT CHARACTERISTICS

Frequency Range — 0 to 125 MHz, dc coupled. 10 Hz to 125 MHz, ac coupled.

Sensitivity — 20 mV RMS sine wave to 100 MHz, 35 mV RMS sinewave to 125 MHz. 60 mV p-p; at min pulse width of 5 ns to 100 MHz. 100 mV p-p at min pulse width of 4 ns to 125 MHz.

Impedance — 1 MΩ paralleled by ≈27 pF.

Attenuation — Selectable 1X, 5X.

Dynamic Range — $V_{in} \leq 3 V$ p-p; x Attenuation.

Trigger Level — Adjustable ±3.5 V x Attenuation.

Independent Controls — Slope +/–, Atten. 1X/5X, Coupl. AC/DC, Source INT/EXT.

Max Input Voltage —

1X: 200 V peak; 400 V p-p from dc to 50 kHz, derate to 15 V p-p from 1.33 MHz to 125 MHz.

5X: 200 V peak, 400 V p-p from dc to 5 MHz, derate to 20 V p-p from 100 MHz to 125 MHz.

Shaped Out — Shaped replica of signal being measured, aids proper triggering on complex waveforms. ≥200 mV p-p from 50 Ω.

Trigger Level — A dc level corresponding to the actual trigger level. Accuracy ±20 mV ±0.5% of reading.

FREQUENCY A

Range — 0 to 125 MHz.

Resolution — 0.1 Hz to 10 MHz in decade steps.

Accuracy^a = ±1 count ± time base error x Frequency A.

PERIOD B (SINGLE SHOT)

Range — 100 ns to 10⁹ s.

Resolution — 100 ns to 10 s in decade steps.

Accuracy^{a,c} = ±1 count ± time base error x Period B ±1.4 x Ch B trigger jitter error.

Frequency Range — 0 to 125 MHz.

PERIOD B (Average)

Range — 8 ns to 10 s.

Resolution — 1 fs (10⁻¹⁵) to 100 ns in decade steps.

Number of Average — N = 1 to 10⁸.

Accuracy^{a,b,c} = ± $\frac{100 \text{ ns}}{N}$ ± time base error x Period B

± $\frac{1.4 \times \text{Ch B trigger jitter error}}{N}$

Frequency Range — 0 to 125 MHz.

WIDTH B (SINGLE SHOT)

Range — 100 ns to 10⁹s.

Resolution — 100 ns to 10 s in decade steps.

Accuracy^{a,c,d} =

±1 count ± time base error x Width B.
 ± Ch B start trigger jitter error
 ± Ch B stop trigger jitter error
 +(Ch B stop slew rate error—Ch B start slew rate error).

WIDTH B (AVERAGE)

Range — 5 ns to 10 s.

Resolution —

$$\frac{100 \text{ ns}}{\sqrt{N}}$$

Number of Averages — N = 1 to 10⁸ in decade steps.

Accuracy^{a,b,c,d} =

$$\pm \frac{100 \text{ ns}}{\sqrt{N}} \pm \text{time base error} \times \text{width B.}$$

$$\pm \frac{\text{Ch B start trigger jitter error}}{\sqrt{N}}$$

$$\pm \frac{\text{Ch B stop trigger jitter error}}{\sqrt{N}}$$

+(Ch B stop slew rate error — Ch B start slew rate error)

Frequency Range — 0 to 100 MHz.

TIME A → B (SINGLE SHOT)

Range — 100 ns to 10⁹s.

Resolution — 100 ns to 10 s in decade steps.

Accuracy^{a,c,d} =

$$\pm 1 \text{ count} \pm \text{time base error} \times \text{Time A} \rightarrow \text{B}$$

$$\pm \text{Ch A trigger jitter error}$$

$$\pm \text{Ch B trigger jitter error}$$

$$\pm (\text{Ch B stop trigger slew error} - \text{Ch A start trigger slew error}) \pm 4 \text{ ns.}$$

TIME A → B (AVERAGE)

Range — 12.5 ns to 10 s.

$$\text{Resolution} = \frac{100 \text{ ns}}{\sqrt{N}}$$

Minimum Dead Time — 12.5 ns (Stop-to-Start).

Number of Averages — N = 1 to 10⁸ in decade steps.

Accuracy^{a,b,c,d} =

$$\pm \frac{100 \text{ ns}}{\sqrt{N}} \pm \text{time base error} \times \text{Time A} \rightarrow \text{B}$$

$$\pm \text{Ch A trigger jitter error}$$

$$\pm \frac{\text{Ch B trigger jitter error}}{\sqrt{N}}$$

$$\pm \frac{\text{Ch B trigger jitter error}}{\sqrt{N}}$$

$$+ (\text{Ch B stop trigger slew error} - \text{Ch A start trigger slew error}) \pm 4 \text{ ns}$$

EVENTS A DURING B (AVERAGE)

Max A Frequency — 125 MHz.

Min B Pulse Width — 5 ns.

Number of Averages — N = 1 to 10⁸ in decade steps.

Accuracy^{b,c,d} —

$$\pm \frac{\text{Period A}}{\text{Width B} \times \sqrt{N}} \times \text{Events A during B}$$

$$\pm \frac{\text{Ch B start trigger jitter error}}{\sqrt{N}} \times \text{Frequency A}$$

$$\pm \frac{\text{Ch B stop trigger jitter error}}{\sqrt{N}} \times \text{Frequency A}$$

$$+ (\text{Ch B stop trigger slew error} - \text{Ch B start trigger slew error}) \times \text{Frequency A}$$

(Note: Frequency in MHz)

RATIO A/B

Averaged over 1 to 10⁸ cycles of channel B signal.

Frequency Range — 0 to 125 MHz (both Channels A & B).

$$\text{Accuracy^{b,c}} = \pm \frac{\text{Frequency B}}{\text{Frequency A} \times N}$$

$$\pm 1.4 \times \text{Ch B trigger jitter error} \times \text{Frequency A}$$

$$\pm \frac{\text{Frequency A}}{0.3 \times 10^8}$$

TOTALIZE A

1 to 99,999,999 counts at max rate of 125 MHz. Start, stop and reset controlled by front panel pushbuttons or rear interface signal lines.

TIME MANUAL

Electronic stopwatch, accumulates and displays time between activation of front panel start/stop button or rear interface signal line. Clock rates selectable from 100 ns to 10 s in decade steps. Range 100 ns to 10⁹ s.

STANDARD TIME BASE

Crystal Frequency — 10 MHz.

Temp Stability — < ±5 x 10⁻⁶, 0°C to 50°C.

Aging Rate — < 1 x 10⁻⁶ per year.

Setability — Adjustable to within 5 x 10⁻⁸.

OPTION 01 HIGH STABILITY TIME BASE

Crystal Frequency — 10 MHz.

Temp Stability — < ±2 x 10⁻⁷ after warm-up, 0°C to 50°C.

Warmup Time — Within 2 x 10⁻⁷ of final frequency in <10 minutes when cold started at 25°C.

Aging Rate — 1 x 10⁻⁸/day at time of shipment, 4 x 10⁻⁸/week after 30 days of continuous operation, 1 x 10⁻⁶/year after 60 days of continuous operation.

Setability — Adjustable to within 2 x 10⁻⁸.

REAR INTERFACE

Inputs — Direct count input to 50 MHz, (50 Ω impedance, resistor may be removed for 1 MΩ impedance, remote start/stop, reset; external time base.

Outputs — BCD serial-by-digit, decimal point, overflow, scan clock; trigger level; time base reference.

NOTES:

A) Time base error is the sum of all errors specified for the time base used.

B) N is the number of periods averaged in PERIOD B (AVGS) mode, the number of intervals averaged in the TIME A-B (AVGS) mode, the number of widths of B averaged in WIDTH B (AVGS) and EVENTS A DURING B modes, and the number of periods of B in the RATIO A/B mode.

C) Trigger jitter error = (in μs)

$$\sqrt{(en_1)^2 + (en_2)^2} \text{ (V)}$$

$$\frac{\text{Input slew rate at trigger point (V/}\mu\text{s)}}{\sqrt{N}}$$

Where en₁ = 100 μV RMS typical internal noise.

en₂ = RMS noise of the signal input at the trigger point for a 125 MHz bandwidth.

D) Trigger slew rate error = (in μs)

$$\frac{\text{Input hysteresis (V)}}{2}$$

$$\frac{\text{Input slew rate at set trigger point (V/}\mu\text{s)}}{2}$$

Where input hysteresis = 20 mV p-p typical.

ORDERING INFORMATION

DC 503A \$930
Option 01 High Stability Time Base Add \$275

DC 504

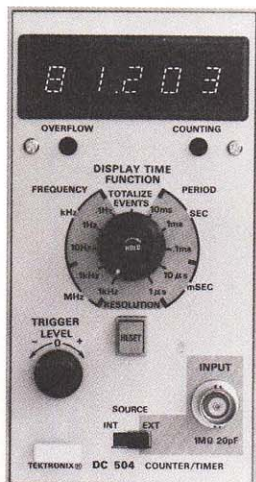

Counter/Timer

DC 504 Counter/Timer

Direct Frequency Counting to 80 MHz

Period Measurement for Resolution at Low Frequency

Rpm Counting

5 Digit LED Display

Low Cost

The DC 504 Counter/Timer measures frequency from 0 Hz (with 0.1 Hz resolution) to 80 MHz, period from 1 microsecond to 999.99 seconds, and totalizes events from 0 to 99,999 at a maximum rate of at least 80 MHz. A resolution of 0.1 Hz can be obtained by allowing the more significant figures of the counter to overflow. Five 7-segment lightemitting diodes (LEDS) provide a visual numerical display. The decimal point is automatically positioned and leading zeros are blanked. Digit overflow is indicated by a front-panel LED. Signals to be counted/timed can be applied to either a front-panel BNC connector or to the rear interface connector. Internal switches select frequency or rpm operation, internal time base or external standard, and override display storage.

CHARACTERISTICS

Display — 5 digits LED display.
Accuracy — ± 1 count \pm time-base accuracy (\pm trigger error in period mode only).
Frequency (or rpm) — Dc coupled: 0 Hz to at least 80 MHz. Ac coupled: 10 Hz to at least 80 MHz.
Frequency/rpm (Max Resolution) — kHz Positions: 0.1 Hz, 1 Hz, and 10 Hz (1 rpm, 10 rpm, and 100 rpm). * MHz Positions: 0.1 kHz and 1 kHz (1000 rpm and 10 k rpm). *
Sensitivity — 20 mV RMS (56.6 mV p-p) below 15 MHz, 35 mV RMS (99 mV p-p) at or below 50 MHz derating to typically < 175 mV RMS (495 mV p-p) at 80 MHz.
Triggering Level — Adjustable from at least -1.5 V to $+1.5$ V.
Trigger Source — Internal (rear connector interface) or external (front-panel BNC).
Max Input Voltage — (sinewave, dc + peak ac) ± 250 V at 500 kHz or less; derate -20 dB/decade to 25 MHz. ± 5 V from 25 MHz to 80 MHz.
Impedance — 1 M Ω paralleled by ≈ 20 pF.
Coupling — Dc or ac.
Internal Time Base —

| | Standard | Option 01 |
|--|---------------------------------------|---------------------------------------|
| Crystal Frequency | 1 MHz | 5 MHz temperature compensated |
| Stability (0°C to 50°C) after ½ hour warm-up | $\leq \pm 1 \times 10^{-5}$ | $\leq \pm 5 \times 10^{-7}$ |
| Long-term Drift | $\leq \pm 1 \times 10^{-5}$ per month | $\leq \pm 1 \times 10^{-7}$ per month |
| Setability | Adjustable to $\pm 1 \times 10^{-7}$ | Adjustable to $\pm 5 \times 10^{-9}$ |

Totalize Events (Resolution — 1 count.
Period (Resolution) — mSec Position: 1 μ s and 10 μ s Sec Position: 0.1 ms, and 10 ms.
Display Time — Variable from about 0.1 s to about 10 s. Dentent position at cw position of DISPLAY TIME knob provides a HOLD mode.
Data Inputs and Outputs — Available at rear of plug-in for intra-compartment routing in any TM 500 Power Module/Main-frame. Bcd serial-by-digit (parallel data for one digit at a time) plus timing and control functions.

ORDERING INFORMATION

DC 504 Counter/Timer \$600
Option 01 (Time Base) Add \$200

*This assumes that the transducer output is one pulse per revolution.

OPTIONAL COUNTER ACCESSORIES

P6101 X1 Probe, Dc to 34 MHz
 Order 010-6101-03 \$53
P6106 X10 Probe, Dc to 300 MHz
 Order 010-6106-03 \$125
P6201 FET Probe, Dc to 900 MHz
 Order 010-6201-01 \$990
P6056 50 Ω , X10 Probe, Dc to 3.5 GHz
 Order 010-6056-03 \$140
Power Divider, GR, 50 Ω
 Order 017-0082-00 \$75
Adapter, GR to BNC female
 Order 017-0067-00 \$55
Adapter, GR to BNC male
 Order 017-0064-00 \$60
Cable, adapter, BNC to tipjack (DC 503A, DC 509, DC 5009)
 Order 175-3765-01 \$23
Cable, Adapter, BNC to Rf (DC 510, DC 5010)
 Order 012-0532-00 \$23

P6125 COUNTER PROBE 5X



The P6125 is a low-capacitance, 5X attenuation passive probe specially designed for use with counter/timers. It makes possible more accurate time interval measurements of high speed logic signals. Five-times attenuation provides an optimum match between the counter input characteristics and the voltage levels of all common logic families. The low input capacitance permits acquisition of high frequency signals with minimum loading of the circuits under test.

CHARACTERISTICS

Attenuation — 5X.
Input Resistance — 5 M Ω Input.
Capacitance — ≈ 20 pF.
Bandwidth — Dc to 200 MHz.
Voltage Rating — 250 V (dc + peak ac) derated to 35 V at 100 MHz.
Cable Length — 1.5 meters.

INCLUDED ACCESSORIES

352-0351-00 1 HOLDER, probe
 013-0107-03 1 TIP, retractable hook
 * 1 TIP, IC tester
 ** 2 TIPS, probe
 344-0046-00 2 CLIPS, miniature, alligator
 175-0124-01 1 LEAD, ground, 13 cm
 175-0263-01 1 LEAD, ground, 8 cm
 166-0404-01 1 SLEEVE, insulating
 016-0521-00 1 POUCH, accessory

*Available in packages of 10 (015-0201-04) or 100 (015-0201-05) only.

**Available in packages of 10 only (206-0191-03).

P6125 Counter Probe, 5X, 1.5 m, Order 010-6125-01 \$53

NEW
PS 5010

GPIB
IEEE-488

The PS 5010 is designed to comply with IEEE Standard 488-1978, and with Tektronix Codes and Formats Standard.

Fully Programmable

Three Programmable ±0 to 32 V Dual Floating Supply to 0.75A (1.6A to 15 V). +4.5 V to +5.5 V Logic Supply to 3A.

Three Independent Digital Displays

Programmable Voltage and Current Limits Over Full Range

Automatic Crossover

Powerful Set of GPIB Status Reporting Commands

Front Panel Lock-Out Capability

Programmable Output ON/OFF (Independent ON/OFF for Floating Supply and Logic Supply)

±0.5% Accuracy

PS 5010

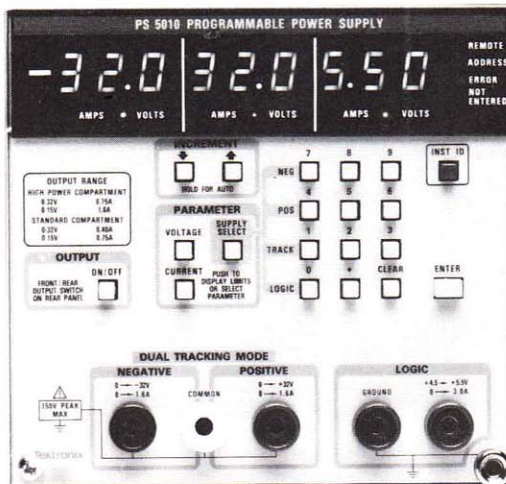

Programmable Triple Power Supply

The PS 5010 Programmable Power Supply is a two-wide TM 5000 module that provides a complete and rapid high performance solution for many system power supply applications. It's three supplies provide the most commonly used voltages, and the three digital displays automatically indicate all six voltage and current limit parameters. Automatic crossover from voltage to current limit and a powerful set of GPIB status reporting commands allow the user to be constantly aware of the power supply's status. Also, the user can program the output on or off and lock-out the front panel controls with GPIB commands.

The PS 5010's dual floating supply provides 0 to +32 V and 0 to -32 V at up to 0.75 A (1.6 A to 15 V). The logic supply provides +4.5 V to +5.5 V at 3 A. The three supplies can be independently programmed for voltage and current limits. Since the PS 5010's microprocessor monitors the voltage and current feedback loops of each supply, a simulation of true DMM output monitoring of all supplies is possible. Each display indicates the true output voltage or current of that supply. Whenever a load change causes a supply to change modes from constant voltage to constant current (or vice-versa), the display also changes to show the known current limit or voltage value. This condition can be reported over the bus via an interrupt when the PS 5010 is in the remote state.

With its English-like GPIB commands, performance, and combination of features, the PS 5010 Triple Power Supply reduces both software and hardware system development time.

PS 5010 CHARACTERISTICS
POSITIVE AND NEGATIVE FLOATING SUPPLIES

Configuration — Dual floating with shared common terminal.
Isolation — 150 V peak from panel, 42 V peak from rear interface, 0.015 μf typical shunt capacitance to ground.

Voltage Range — 0 to +32.0 V; 0 to -32.0 V.

Voltage Accuracy — ± (0.5% + 20 mV) overall; ± (0.01% + 2 mV) line regulation; ± 10 mV for 1A load current change (1 mV when using rear interface output with remote sensing).

Voltage PARD (Ripple and Noise) — 10 mV p-p; 20 Hz to 20 MHz.

Voltage Resolution — 10 mV ± 10 mV (typ ± 2 mV) to 10.0 V, 100 mV ± 40 mV (typ ± 10 mV) > 10.0 V.

Load Transient Recovery — 500 μs to recover within 20 mV of nominal value for a 1 A change.

Voltage Change Response Time — 1 ms for up or down change, 20 ms for down change with no load.

Current Limit Range — 50 mA to 0.75 A (1.60 A at 15 V and below) in high power compartment; 50 mA to 400 mA (0.750 A at 15 V and below).

Current Limit Accuracy — ± (5% + 20 mA) overall; ± 1 mA line regulation; ± 10 mA load regulation. Output impedance is typically 5 kΩ shunted by 20 μF.

Current Mode PARD (Ripple and Noise) — 10 mA p-p, 20 Hz to 20 MHz.

Current Change Response Time — 20 ms up or down.

Current Resolution — 50 mA ± 15 mA.

LOGIC SUPPLY

Voltage Range — +4.50 to +5.50 V, ground referenced.

Voltage Accuracy — ± 50 mV overall; ± 1 mV line regulation; ± 10 mV for 1 A load current change (1 mV when using rear interface output with remote sensing)

Voltage PARD (ripple and noise) — 10 mV p-p, 20 Hz to 20 MHz.

Voltage Resolution — 10 mV ± 10 mV (typ ± 2 mV).

Load Transient Recovery — 500 μs to recover within 20 mV of nominal value.

Current Limit Range — 100 mA to 3.0 A (Foldback characteristic below 4.5 V, maximum short circuit current is <1.5 A).

Current Limit Accuracy — ±(5% + 20 mA).

Current Resolution — 100 mA ± 30 mA.

Scaled Current Output — 10 mA = 2 mV ±(2% + 1 mV) available at rear interface (not ground referenced).

Overvoltage Protection — SCR crowbar typically trips at 6.7 V.

OTHER CHARACTERISTICS

Operating Temperature — 0°C to +50°C.

Storage Temperature — -55°C to +75°C.

Operating Altitude — 4.6 km (15,000 ft).

Storage Altitude — 15 km (50,000 ft).

Power Consumption — 250 VA max in high power compartment, 200 VA in standard compartment.

Order PS 5010 Power Supply \$2500

CHARACTERISTICS COMMON TO PS 501-1, PS 503A

20 V FLOATING SUPPLY

Primary Power Input — Determined by mainframe (TM 501, TM 503, etc).

Output — Floating, isolated for 350 V dc + peak ac above ground.

Stability — Typically (0.1% + 5 mV) or less drift in 8 hours of constant line, load, and temperature.

Indicator Lights — Voltage variation and current limit.

+ 5 V GROUND-REFERENCED SUPPLY

Output — 5 V nominal, ± 0.25 V at 1 A.

Load Regulation — Within 100 mV with a 1 A load change.

Line Regulation — Within 50 mV for a 10% line voltage change.

Ripple and Noise (1A) — 5 mV p-p or less, 20 Hz to 5 MHz.

Stability — Typically 30 mV or less drift in 8 hours.

Overload Protection — Automatic current limiting and over-temperature shutdown.

PS 503A

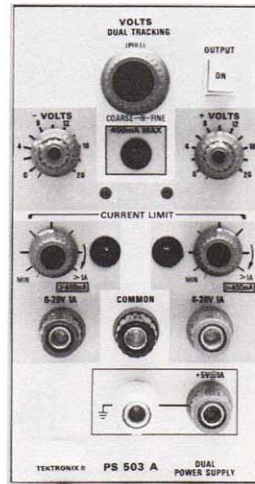

Triple Power Supply

PS 503A

Independent + and - Controls

Dual Tracking Voltage Control

0 to ± 20 V at 1 A (in High-power Compartment)

Fixed Output + 5 V @ 1 A

Remote Resistance Programming

Over-Voltage Protection Standard

The PS 503A features superior dual tracking performance, over-voltage protection, and remote resistance programming of voltage. When operated in the high-power compartment of a TM 504 or TM 506 Mainframe, the PS 503A provides up to 1 amp from both 0 to 20 volt supplies.

± 20 V FLOATING SUPPLIES

Outputs — 0 to ± 20 V dc with respect to the common terminal or 0 to 40 V dc across the + and - terminals. Outputs can be varied independently or at a constant ratio.

Maximum Rated Current — 400 mA (1 A in high power compartment to +30°C derating to 300 mA (750 mA) at +50°C.

Tracking Mode Offset Error — If the two supplies are set independently to any given voltage ratio and then varied by use of the VOLTS DUAL TRACKING control, the two supplies will maintain the same voltage ratio as initially set within ± 50 mV.

Current Limit — Adjustable from <100 mA to 1 A (high-power compartment) or <40 mA to 400 mA (standard compartment) on each supply.

Load Regulation — Within 3 mV for 1 A change (high-power compartment) or 1 mV for 400 mA change (standard compartment).

Ripple and Noise — 3 mV p-p or less at 1 A load (high-power compartment). 0.5 mV p-p or less at 400 mA load (standard compartment).

Indicators — Individual voltage indicators and current limiting indicators for both + and - supplies. Standard compartment (400 mA) indicator.

Order PS 503A Power Supply \$540

PS 501-1

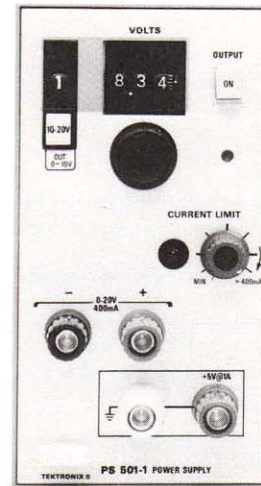

Power Supply

PS 501-1

Floating Output, 0-20 V

0 to 400 mA

Precise Regulation

Low Ripple and Noise

Fixed Output + 5 V @ 1 A

3 1/2 Digit Ten Turn Dial

The PS 501-1 features precise regulation and better than 2 mV resolution (setability) over a 0 to 20 V range.

Output — 0 to 20 V dc.

Maximum Rated Current — 400 mA to +30°C derating to 300 mA at +50°C.

Accuracy — $\pm(0.5\% + 10$ mV).

Current Limit — <40 to 400 mA.

Line Regulation — Within 5 mV for a +10% line voltage change.

Load Regulation — Within 1 mV for a 400 mA load change.

Ripple and Noise — 0.5 mV p-p or less; 20 Hz to 5 MHz.

Temperature Coefficient — Typically <(0.01% + 0.1 mV) per °C.

Minimum Resolution — Typically 1.6 mV.

Transient Recovery Time — 20 μ s or less to recover within 20 mV of final output voltage after a 400 mA change in output current.

Order PS 501-1 Power Supply \$430

DL 502



Digital Latch

DL 502

16 Channel Latching Capability

Captures Glitches as Narrow as 5 ns at Probe Tips

Allows Expansion of Information Time Frame

TM 500 Compatibility

The DL 502 Digital Latch extends the logic analyzer's measurement capabilities. The Digital Latch aids in detecting narrow pulses in a data stream that cannot be captured by a logic analyzer alone. The 16 channel latch captures asynchronous glitches of less than one sample interval or as narrow as 5 ns.

In asynchronous measurements without latching capability, high speed data anomalies go undetected if they do not appear on a clock edge. The DL 502 Digital Latch captures the glitch and holds it until the next clock edge, then expands and displays it for one sample interval.

CHARACTERISTICS

- Minimum pulse width to initiate latch** — 5 ns.
- Minimum amplitude to initiate latch** — 500 mV centered at threshold.
- Minimum sample interval asynchronous clock** — 50 ns.

Order DL 502 Digital Latch \$1600

Standard accessories include instruction manual, 6 inch BNC cable.

DD 501

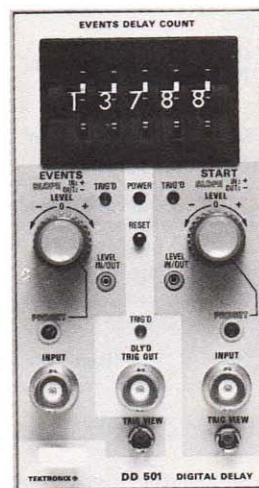

DD 501

Digital Events Delay

Delay to 99,999 Events

Divide by N up to 20 MHz

Pulse Counting to 65 MHz

Time Delay with Ext Clock

Compatible with Most Attenuator Probes

The DD 501 is an events count or count down plug-in unit. The unit counts a predetermined number of events, from 0 to 99,999, selected by the front-panel thumb-wheel switches. The DD 501 can also function as a frequency divider, or it can be used in a "counted burst" mode with pulse or function generators that can be synchronously gated. Tektronix generators capable of being gated by the DD 501 are the FG 501, FG 502, FG 504, FG 507, FG 5010, PG 508 and the PG 507.

EVENTS DELAY

- Count** — 10 to 99,999 events.
- Max Count Rate** — 65 MHz.
- Insertion Delay** — 30 ns or less from final event to trigger output pulse.
- Recycle Time** — 50 ns or less.
- Reset** — Manually resets delay counter.

INPUT CHARACTERISTICS

- (All characteristics apply to both events and start inputs).
- Input Impedance** — 1 M Ω , 20 pF.
- Slope** — Either + or -, selectable.
- Sensitivity** — 85 mV p-p @ 30 MHz.
- Frequency Response** — Up to 65 MHz at 120 mV sensitivity.
- Minimum Detectable Pulse Width** — 5 ns.
- Threshold Level Range** — From -1.0 V to +1.0 V (-10 V to +10 V with 10X probe). Can be externally programmed or monitored at front panel jacks.
- Trigger View Out** — Threshold detector output, at least 0.5 V (200 Ω or less source impedance).
- Events Triggered Light** — Visual indication that events are being detected.
- Start Triggered Light** — Visual indication that delay is in progress.

TRIGGER OUTPUT

- Pulse Width** — Width of events pulse plus 6 ns or less.
- Voltage Swing** — + 0.8 V or less to at least + 2.0 V with 3 TTL loads (\approx 5 mA).
- Light** — Indicates output trigger.

GENERAL

- Temperature** — Operating: 0°C to +50°C. Nonoperating: -40°C to +75°C.
- Altitude** — Operating: to 15,000 ft; Nonoperating: to 50,000 ft.

Order DD 501 Digital Delay \$1170

WR 501



Word Recognizer with Digital Delay

WR 501

The WR 501 is a 16 bit parallel Word Recognizer with digital delay that produces trigger pulses when a preselected word occurs. It occupies one plug-in position in any TM 500 Series Power Module Mainframe.

The WR 501 may also be used separately as a word recognizer to generate triggers for oscilloscopes or other measurement instruments. It gives you fast access to any unique word in the data stream.

WORD RECOGNIZER (WR 501)

- Inputs** — 15 data inputs plus a clock and qualifier.
- Word Selection** — Made using sixteen three-position toggle switches. Positions are HI, (don't care), and LO.
- Qualifier** — Can expand the word recognizer to 17 bits, act as a gate for the external clock or do both.
- Clock** — Selects positive- or negative-going edge of clock input signal. Used for synchronous operation.
- Modes** — Front panel selection of synchronous word recognition (a trigger is produced only when the operator selected word occurs at a clock edge; either position, positive or negative edge, may be selected), or asynchronous word recognition (a trigger is produced anytime the recognized word occurs).
- Synchronous Mode** — Minimum set-up time 18 ns. Minimum Hold time 0 ns. (Filter is automatically disabled)
- Asynchronous Mode and Filter** — Minimum coincidence time is variable from 15 ns or less to 200 ns or more.

Order WR 501 Word Recognizer \$2000

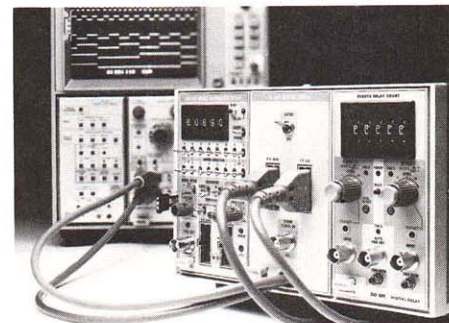

The DL 502 Digital Latch and WR 501 Word Recognizer are TM 500 Plug-ins compatible with all Tektronix Logic Analyzers (see page 55).

COMPARISON OF CHARACTERISTICS

| PG 501 | PG 502 | PG 505 |
|---|---|--|
| ≤ 20 ns to ≥ 200 ms (50 MHz to 5 Hz) | ≤ 4 ns to ≥ 100 ms (250 MHz to 10 Hz) | ≤ 10 μs to ≥ 1 s (100 kHz to 1 Hz) |
| ≤ 10 ns to ≥ 100 ms | ≤ 2 ns to ≥ 50 ms | ≤ 5 μs to ≥ 0.5 s |
| ≥ 70% to 0.2 μs period, ≥ 50% at 20 ns period | ≥ 50% | approaches 100% |
| NO | YES | NO |
| Fixed, 20 ns from external trigger | Fixed, 17 ns from external trigger | Anywhere along +10 V external ramp |
| NO | NO | NO |
| Fixed, ≤ 3.5 ns | Fixed, ≤ 1.0 ns | ≤ 1 μs to ≥ 20 ms. Independently variable up to 20:1 |
| Within 3.5% at 5 V into 50 Ω load | Within 5% at 5 V p-p (durations ≥ 5 ns) | Within 5% at max output into 4 kΩ, 20 pF load |
| ≥ 5 V | 5 V, ±5 V window | typ +1 V or -1 V |
| not specified | 5 V, ±5 V window | ≥ +80 V or ≥ -80 V |
| not specified | 1 kΩ or 50 Ω | 4 kΩ |
| YES, positive and negative | NO | NO |
| ≤ 1 ns at 50% amplitude | NA | NA |
| Independent amplitude controls for + and - outputs, no offset | Independent pulse top and pulse bottom | Amplitude control, no offset |
| NO | YES | NO |
| NO | NO | YES |
| NO | NO | NO |
| YES | NO | YES |
| NO | YES, switchable | NO |
| 50 Ω input Z | 50 Ω input Z | 10 kΩ input Z |
| +1 V required | +1 V required | +0.5 V to +10 V |
| + Only | + Only | + Only |
| YES | YES | YES |
| NO | YES | NO |
| YES | YES | YES |
| NO | NO | NO |
| NO | NO | NO |
| ≥ +2 V from 50 Ω, approx. 8 ns prior to pulse output | ≥ +2 V from 50 Ω, approx. 10 ns prior to pulse output | ≥ +4 V from 200 Ω |
| NO | NO | User installed capacitors |
| NO | NO | NO |

0°C to +50°C Operating, -55°C to +75°C Non-operating

PG 508

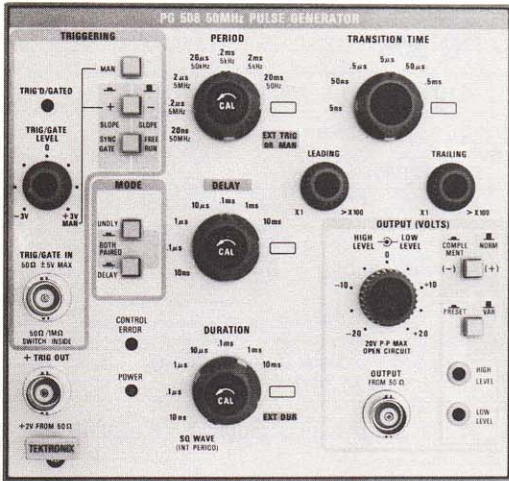

50 MHz Pulse Generator

PG 507

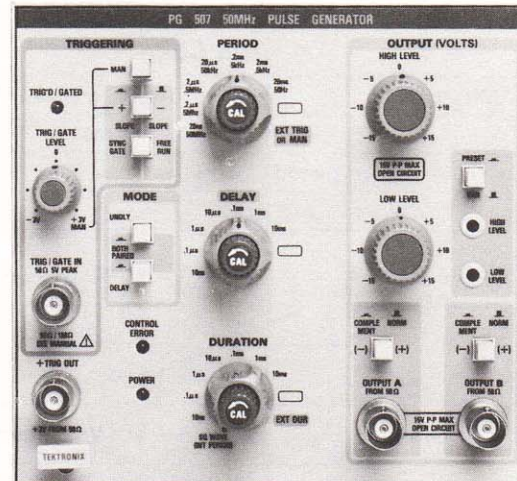

50 MHz Dual Output Pulse Generator

PG 507/PG 508

Common Characteristics

5 Hz to 50 MHz Plus Custom Range

Delay and Double Pulse Capability

Independent Pulse Top and Bottom Level Controls

True 50 Ω Output Impedance for Clean Waveforms

Control Error Light Warns of Improperly Set Switch or Variable Controls

3 State Trigger Light Indicates Proper External Triggering

Selectable 1 M Ω /50 Ω Trigger Input Impedance for Optimum Match to Circuitry — Lets You Use Your Scope Probe

The PG 507 and PG 508 combine TM 500 configurability with state-of-the-art capabilities. Their high-level performance and unique versatility cover a broad range of test and measurement applications and logic design functions in MOS, CMOS, TTL and ECL.

With an output of up to 15 V p-p for the PG 507 and 20 V p-p for the PG 508, both instruments also feature independent controls for output period, delay and duration times. Other features include selectable 1 M Ω /50 Ω trigger input impedance, a control error light, a 3 state trigger/gate light, and preset or external control of output voltage levels.

Simply pushing the preset button can change the output from variable top and bottom controls to front panel screwdriver adjustments, or track external supply voltages.

The complement mode of either generator allows an output duty cycle range approaching 100% to be conveniently set up with more accuracy, range and stability.

You can gate the PG 507 or PG 508 with a positive- or negative-going signal, or by pressing the MAN button. Or dial up a predetermined number of pulses in a burst by adding the DD 501's independent digital delay capabilities for Counted Burst mode; especially useful for testing circuits at different frequencies with the same number of pulses.

And there's more; with the trigger input switched to 1 M Ω impedance, you can explore circuitry using a 1X or 10X scope probe. The PG 507 or PG 508 can be used as a pulse regenerator, logic level translator, or sine wave to pulse converter.

The PG 507's and PG 508's output is capable of driving MOS, CMOS, DTL, HTL I^2L , T^2L or ECL.

PG 507

Dual Outputs with Tracking Level Controls

Normal or Complement Pulse Output on Both Channels

15 V Output in a ± 15 V Window into Hi Impedance, 7.5 V into 50 Ω

3.5 ns Rise/Fall Time

The PG 507 is a high performance, 50 MHz pulse generator designed specifically for logic design applications.

The PG 507 features complementary dual outputs which greatly increase its applicability in logic design areas, especially interfacing within systems or to peripherals. For instance, the complementary outputs allow simulation of line drivers or opposite phase clocks.

The PG 507 also offers versatility to the design engineer in an analog environment. For example, the dual outputs can be used to test differential input amplifiers or multiplexers.

The PG 507 features four output modes: normal complement mode (Channel A output positive going, Channel B output negative going), opposite phase complement mode (Channel A output negative going, Channel B output positive going), simultaneous negative mode (Channel A output negative going, Channel B output negative going), and simultaneous positive mode (Channel A

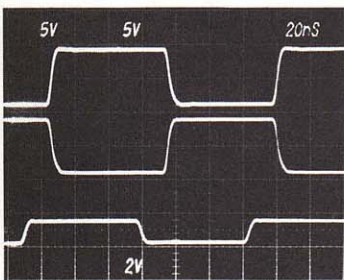

PG 507 trigger output and outputs switched to complementary mode.

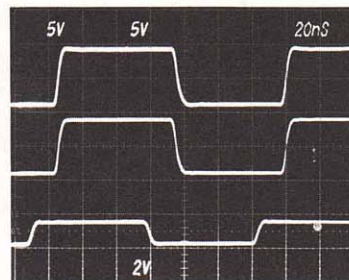

PG 507 trigger output and outputs switched to positive going mode.

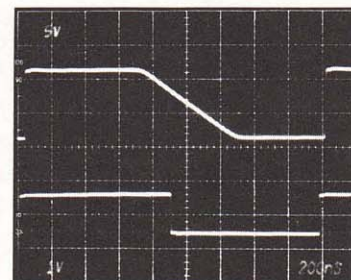

PG 508 output with fall times set 100 times longer than rise time.

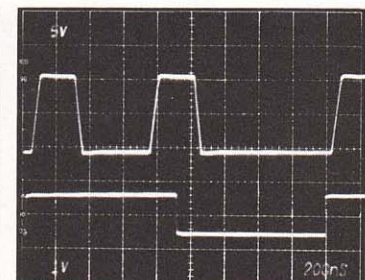

PG 508 output in paired pulse mode with rise and fall times set equally.

output positive going, Channel B output positive going).

In addition, the Output High Level and Low Level voltage controls track between channels, making amplitude settings easy.

This unique output flexibility within the normal and complement modes is particularly useful in logic design or control applications requiring simultaneous signals.

ORDERING INFORMATION

PG 507 50 MHz Pulse Generator \$1810
DD 501 Digital Delay (page 267) \$1170

P6062B and P6108 Probes are recommended.

PG 508

Independently Variable Rise and Fall Times to 5 ns

20 V Output in a ± 20 V Window to Hi Impedance, 10 V into 50 Ω

Normal or Complement Output

The PG 508 50 MHz Pulse Generator is a highly versatile, general purpose pulse generator. The circuitry of the PG 508 is designed so that rise and fall waveforms closely simulate real world waveforms. This capability is particularly useful in research and development applications demanding versatility in rise and fall times like testing of amplifiers, slew rate testing, comparator simulation and logic circuitry performance tests.

For example, controllable rise and fall times are extremely desirable when working with CMOS where logic power consumption increases with slower rise times. Also, variable rise and fall times are used to reduce ringing (transient distortion) problems associated with too fast a pulse.

The PG 508 features a vernier control on the rise and fall times controllable from 100 to 1. This completely overlaps the next decade range and increases the PG 508's versatility in applications simulating different rise and fall times, especially the output of nonlinear devices. This overlap feature can also be used to generate a ramp signal or simulate unequal slew rates in an amplifier.

Also adding to the simplicity of using the PG 508, is the capability of changing output amplitude while variable rise and fall times remain constant.

ORDERING INFORMATION

PG 508 50 MHz Pulse Generator \$1810
PG 508T 50 MHz Pulse Generator \$2095
 (includes PG 508, TM 503 Mainframe, and 016-0195-03 blank panel).

For counted Burst, order the **DD 501 Digital Delay (page 267) \$1170**

Suggested 10 in BNC 50 Ω cable (2 req) for interconnecting PG 508 and DD 501:
012-0208-00 \$17

P6062B and P6108 Probes are recommended.

PG 501



50 MHz Pulse Generator

PG 502

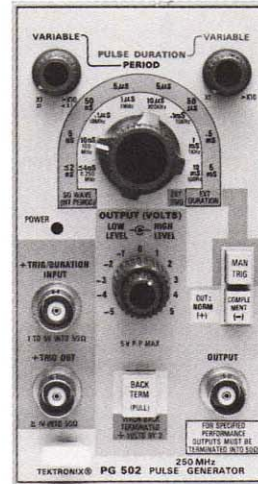

250 MHz Pulse Generator

PG 505

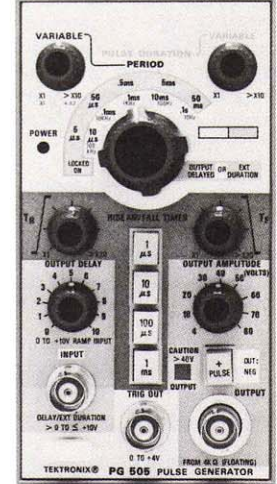

100 kHz Pulse Generator

PG 501

5 Hz to 50 MHz

Simultaneous Plus and Minus Outputs

5 V and 3.5 ns into 50 Ω

Independent Period and Duration Controls

Trigger Out

The PG 501 is a 50 MHz Pulse Generator featuring simultaneous plus and minus outputs; a wide range of pulse period durations, and duty factors; trigger output and external trigger/duration input. Its performance and ease of operation make it well-suited to basic digital and analog applications.

Order PG 501 50 MHz Pulse Generator . \$650

PG 502

10 Hz to 250 MHz

1 ns Rise Time

5 V OutPut ± 5 V Window

Independent Pulse Top and Bottom Level Controls

Selectable Internal Reverse Termination

Manual Trigger Button

The PG 502 (250 MHz Pulse Generator) features: fast rise and fall times; independent top and bottom pulse levels; and adjustable pulse duration. The fast rep rate makes the instrument ideal for design and testing of fast logic and switching circuits.

Order PG 502 250 MHz Pulse Generator \$2310

PG 505

1 Hz to 100 kHz

Independently Variable Duration and Period

80 V Output

Variable Rise Time and Fall Time

Delay Mode

The PG 505 Pulse Generator features: floating output; independently adjustable rise and fall times; external control of period or period and duration. A special position on the pulse period and pulse duration controls allows addition of an internal capacitor to custom-select pulse period and duration. When driven from an externally supplied 0 to 10 volt ramp, the delay control of the PG 505 permits the output pulse to occur at any selected voltage point on the ramp, thus providing controllable time delay to any set time along the ramp.

Order PG 505 100 kHz Pulse Generator \$840

MANUAL (ONE-SHOT) TRIGGER GENERATOR

The Manual (one-shot) Trigger Generator is used for manually initiating a pulse or complete train of events with instruments which do not have a manual trigger button or where a remote operation capability is desired, such as with some oscilloscopes and the PG 501, PG 505, and PG 501.

Order 016-0597-00 \$125

For full programmability and IEEE-488 compatibility, select the new FG 5010 Microprocessor based 20 MHz function generator featuring: 10 complete stored front panel setups, counted burst and phase lock capabilities as well as programmable symmetry and phase. Basic frequency accuracy is 0.1% and all signals can be AM and FM modulated.

For applications demanding logarithmic or linear sweep the FG 507 offers an accurate and versatile solution. The low distortion of the FG 507 (0.25%), combined with log and lin sweep is particularly useful in audio and communications-oriented applications.

For low-frequency function generator applications, set the FG 501A, FG 502, FG 503, or FG 507 to work on biological, geophysical and mechanical simulations or on servo systems.

Applying an external ramp to the vcf (Voltage Controlled Frequency) input, allows our function generators to double as sweep generators. The vcf input fed from a low-level modulating signal can produce a frequency-modulated carrier. The FG 507 and FG 504 have sweep capabilities conveniently built in that simplify setting up start and stop frequencies in addition to providing logarithmic sweep.

Sweeping wide frequency ranges (100:1 or greater), with logarithmic sweep allows you to spread out lower octaves, sweep a full range in less time, and produce easy-to-read Bode plots and graphs.

You can control the starting phase of a waveform with the FG 501A, FG 504, FG 507 and FG 5010 in the gated (burst) or triggered mode. A gated or triggered waveform efficiently tests tone-controlled systems, loud speaker transient response characteristics, automatic gain control circuits, or other amplitude sensitive systems.

The FG 504's phase lock mode feature lets you convert digital signals to high or low voltage sine waves, pulses, or triangles; ideal for locking the function generators output to a house or system frequency standard. With the DD 501 Digital Delay Generator in the "divide by n" mode, the FG 504 can be locked to your frequency reference at a lower frequency.

When your test and measurement problems require more waveforms for more applications, the high performance TM 500 Function Generators are a versatile solution singly or in combination with one another.

FG 501A

FG 507

| Waveforms | Sine, Square, Triangle, Pulse & Ramp with variable symmetry | |
|--|--|--|
| Symmetry | ≤5% to ≥95% Variable | ≤5% to ≥95% Variable |
| Frequency Range | 0.002 Hz to 2 MHz 200 kHz ±10% with variable symmetry on | 0.002 Hz to 2 MHz 200 kHz ±10% with variable symmetry on |
| Dial Accuracy (% of Full Scale) | Within 3% | Within 3% Within 5% in sweep mode ² |
| Custom Frequency Range | NO | NO |
| Frequency Stability (% of Full Scale) | ≤0.05% for 10 min., ≤0.1% for 1 hour, ≤0.5% for 24 hours, constant temperature | |
| Amplitude: Open Circuit | 30 V p-p | 30 V p-p |
| Into 50 Ω | 15 V p-p | 15 V p-p |
| Attenuator | 0 to -60 dB in 20 dB Steps >20 dB additional with AMPL control | |
| Offset: Open Circuit | ±13 V dc, Step attenuator decreases offset | |
| Into 50 Ω | ±6.5 V dc, Step attenuator decreases offset | |
| Pk Sig + Offset: Open Circuit | ±15 V | ±15 V |
| Into 50 Ω | ±7.5 V | ±7.5 V |
| Output Impedance | 50 Ω | |
| Amplitude Flatness (10 kHz ref, 50 Ω load) | Sine wave | ±0.1 dB 20 Hz to 20 kHz ±0.5 dB 20 kHz to 1 MHz ±1 dB 1 MHz to 2 MHz |
| | Triangle | ±0.5 dB 20 Hz to 200 kHz ±2 dB 200 kHz to 2 MHz |
| | Square wave | ±0.5 dB 20 Hz to 2 MHz |
| Sine wave Distortion (Maximum output, 50 Ω load) | ≤0.25% 20 Hz to 20 kHz ⁽¹⁾ ≤0.5% 20 kHz to 100 kHz Harmonics ≤ -30 dB, 100 kHz to 2 MHz | ≤0.25% 20 Hz to 20 kHz ⁽¹⁾ ≤0.5% 20 kHz to 100 kHz Harmonics ≤ -30 dB, 100 kHz to 2 MHz |
| Square Wave Response | ≤25 ns rise/fall ≤3% p-p aberrations | ≤25 ns rise/fall ≤3% p-p aberrations |
| Triangle Linearity (10% to 90%) | ≥99% 20 Hz to 200 kHz ≥97% 200 kHz to 2 MHz | ≥99% 20 Hz to 200 kHz ≥97% 200 kHz to 2 MHz |
| Trigger Output | ≥ +4 V from 50 Ω | |
| External Input | Impedance ≈2 kΩ Trigger threshold level +1 V ±20% | |
| Trigger | ±90° variable start phase control | |
| Gate | ±90° variable start phase control | |
| Phase Lock | NO | |
| Counted Burst | With DD 501 | |
| Internal Sweep | NO | |
| Duration | 1 ms to 100 s | |
| External Trigger | +1 V ±20% trigger level ≈2 KΩ input impedance | |
| Ramp Output | NA | ≤0.3 V to +10 V from 1 KΩ ±5% |
| Gate Output | ≥ +4 V from 50 Ω | |
| Other Modes | Manual Sweep Trig Manual Sweep Sweep and Hold | |
| Amplitude Modulation | NO | |
| Voltage Controlled Frequency (FM) | Up to 1000:1 Frequency change with 10 V external signal. Slew rate ≥0.3 V/ms, 10 kΩ input impedance. | |
| Nominal Hz/Volt sensitivity | 2 x Frequency MULTIPLIER setting | 4 x Frequency MULTIPLIER |
| Output Hold Mode | NO | |
| Temperature ⁽⁴⁾ | 0°C to +50° Operating, -55°C to +75°C non-operating | |

(1) +15°C to +35°C ambient
(2) +20°C to +30°C ambient
(3) 20 Hz to 20 kHz modulation frequency
(4) FG 504 requires forced air circulation above +40°C
(5) Fully Programmable
(6) IEEE 488 Compatible
(7) Percent of indicated frequency
(8) Absolute voltage accuracy
(9) Separate FM function provided (1%/V)

COMPARISON OF CHARACTERISTICS

| FG 504 | FG 502 | FG 503 | NEW FG 5010 ^{(a)(e)} |
|---|---|---|--|
| Sine, Square, Triangle, Pulse & Ramp with variable symmetry | Sine, Square, Triangle Pulse, or Ramp | Sine, Square, Triangle | Sine, Square, Triangle, Pulse & Ramp with variable symmetry |
| 7% to 93% Variable | 5%, 50%, 95% Fixed | 50% Fixed | 10% to 90%, 1% steps |
| 0.001 Hz to 40 MHz 4 MHz nominal with var symm on | 0.1 Hz to 11 MHz Pulse & Ramp, 1.1 MHz | 1.0 Hz to 3 MHz Usable 0.01 Hz to 5 MHz | 0.002 Hz to 20 MHz |
| Within 3% to 4 MHz ¹ Within 6% to 40 MHz ¹ | Within 3% to 1 MHz Within 5% to 10 MHz | Within 5% | Within 0.1% Digital LED Display |
| Shipped with capacitor for 20 Hz to 20 kHz | NO | With user-installed capacitor | NA |
| ≤0.05% for 10 min., ≤0.1% for 1 hour, ≤0.5% for 24 hours, constant temperature | | | ≤.05% for 1 hr., .05% for 24 hrs. (≤.1% in trigger, gate, burst mode >200 Hz) ⁽⁷⁾ |
| 30 V p-p | 10 V p-p | 20 V p-p | 20 V p-p |
| 15 V p-p | 5 V p-p | 10 V p-p | 10 V p-p |
| 0 to -5 dB in 10 dB steps ≤10 mV p-p with VAR control | Variable control only | Variable control only | Digital Control of fixed and Var. 10 mV p-p into 50 Ω |
| ±7.5 V dc | ±5 V dc | ±7.5 V dc | ±7.5 V dc |
| ±3.75 V dc | ±2.5 V dc | ±3.75 V dc | ±3.75 V dc |
| ±20 V | ±10 V | ±15 V | ±15 V |
| ±11.25 V | ±5 V | ±6 V | ±7.5 V |
| 50 Ω | 50 Ω | 50 Ω | 50 Ω |
| ±0.5 dB 0.001 Hz to 40 kHz | ±0.5 dB 20 Hz to 20 kHz ±1.5 dB 0.1 Hz to 11 MHz | ±0.5 dB 20 Hz to 20 kHz ±2 dB 0.1 Hz to 3 MHz | ±3.0% to 5 MHz ⁽⁸⁾⁽¹⁾ +5%-10% to 20 MHz ⁽¹⁾ |
| ±2 dB 40 kHz to 40 MHz | ±3 dB referenced to Sine wave | ±1 dB referenced to Sine wave | ±2% to 500 kHz ⁽⁸⁾⁽¹⁾ +2%, -3.5% to 1 MHz ⁽¹⁾ +3%, -5% to 5 MHz ⁽¹⁾ +5%, -20% to 20 MHz ⁽¹⁾ |
| ±0.5 dB to 20 MHz ±2 dB to 40 MHz | | | ±2% to 1 MHz ⁽⁸⁾⁽¹⁾ ±3% to 5 MHz ⁽¹⁾ ±5% to 20 MHz ⁽¹⁾ |
| ≤0.5% 20 Hz to 40 kHz ⁽¹⁾ Harmonics: ∠ -30 dB 40 kHz to 1 MHz ∠ -20 dB 1 MHz to 40 MHz | ≤0.5% 10 Hz to 50 kHz ⁽²⁾ Harmonics ≤ -30 dB at all other frequencies | ≤0.5% 1 Hz to 30 kHz ∠1.0% 30 kHz to 300 kHz ∠2.5% 300 kHz to 3 MHz | ≤0.5% 20 Hz to 19.99 kHz ⁽¹⁾ ∠1.0% 20 kHz to 99.99 kHz 100 kHz to 20 MHz Harmonic greater than -30 dB |
| ∠6 ns rise/fall fixed 10 ns to 100 ms variable ∠5% p-p +30 mV aberrations | ∠20 ns rise/fall ∠3% p-p aberrations | ∠60 ns rise/fall ∠3 p-p aberrations | ∠10 ns rise/fall ∠5% p-p aberrations |
| ∠99% 10 Hz to 400 kHz ∠95% 400 kHz to 40 MHz typ ≥ 98% 0.001 Hz to 10 Hz | ∠99% 0.1 Hz to 100 kHz ∠97% 100 kHz to 1 MHz ∠95% 1 MHz to 11 MHz | ∠99% 1 Hz to 100 kHz ∠95% 100 kHz to 3 MHz | ∠98% to 2 MHz ∠90% to 20 MHz |
| ∠ +2 V from 50 Ω | +2.5 V to 50 Ω load | +2.5 V to 600 Ω load | +2 V from 50 Ω |
| Impedance ≥10 kΩ Sensitivity ∠1 V p-p Trigger level -1 V to +10 V | Impedance ≈ 1 kΩ ≥ +2 V Gate Signal required | NO | 1 MΩ/50 Ω internal setability 0.0 V/0.5 V internal setability |
| 20 MHz maximum ±80° start phase control to 10 MHz | NO Fixed 0° start phase | NO | ±90° variable start phase control ±90° variable start phase control |
| 100 Hz to 40 MHz ±80° phase range | NO | NO | 20 Hz to 20 MHz (Auto Scan) |
| With DD 501 | With DD 501 | NO | 1-9999 |
| Logarithmic or Linear, Separate Start/Stop Dials | NO | NO | NO |
| 0.1 ms to 100 s | N/A | N/A | N/A |
| +1 V +10 V trigger level 1 V p-p sensitivity | | | |
| 0 to +10 V from 1 kΩ ±5% to 1 ms, ±10% ∠1 ms | | | |
| NO | | | |
| Manual Sweep Trig | | | |
| 100% with nominal 5 V p-p input Dc to 100 kHz modulation freq. ≤5% distortion to 4 MHz @ 70% ⁽³⁾ ≤10% distortion to 40 MHz @ 65% ⁽³⁾ | NO | NO | 100% with nominal 5 V p-p signal input Dc to 100 kHz mod frequency ≤2% distortion to 2 MHz @ 70% ≤4% distortion to 20 MHz @ 70% |
| Up to 1000: 1 Frequency change with 10 V external signal. Slew rate ≥0.3 V/ms, 10 kΩ input impedance. | | | Up to 1000: 1 frequency ⁽⁶⁾ change with 10 V external input |
| 4 x Frequency MULTIPLIER | 1.1 x Frequency MULTIPLIER | 3 x Frequency MULTIPLIER | 10% of selected range |
| 0.001 Hz to 400 Hz | NO | NO | 0.002 Hz to 200 Hz |
| 0°C to +50° Operating, -55°C to +75°C Non-operating | | | |

FG 5010

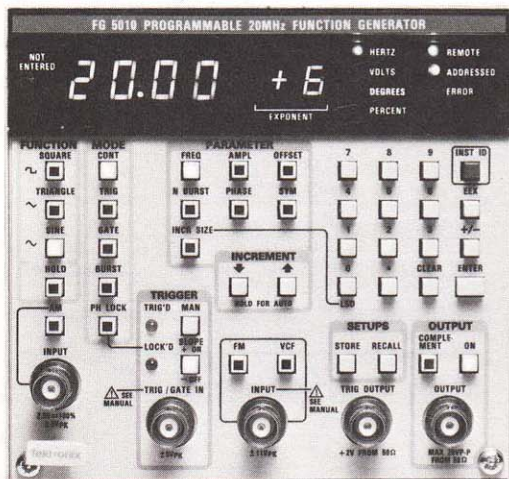

PROGRAMMABLE 20 MHz FUNCTION GENERATOR

NEW

FG 5010

GPIB
IEEE-488

The FG 5010 is designed to comply with IEEE Standard 488-1978, and with Tektronix Codes and Formats Standard.

0.002 Hz to 20 MHz, 4 digits

20 mV to 20 V p-p, ±7.5 V Offset

Sine, Square, and Triangle Waveforms

10%-90% Variable Symmetry in 1% steps

Pulses to 25 ns, 10 ns rise/fall

Trigger, Gate, Burst, and Phase Lock

AM, FM, and VCF

Waveform Complement and Hold

The FG 5010 Programmable 20 MHz Function Generator is a two-wide TM 5000 module with versatile overall performance and an unusually high degree of programmability for many parameters and settings. Its Sine, Square, and Triangle modes are optimized for superior waveform capability and include trigger, gate, counted burst, phase lock, AM, and FM modes. Variable symmetry that is usable to 20 MHz extends pulse and ramp capabilities beyond those of normal generators; and variable phase enhances the trigger, gate, burst, and phase lock modes.

An error correction circuit maintains frequency accuracy within 0.1% over the full 0.002 Hz to 20 MHz range. Automatic phase lock to an external signal is possible from 20 Hz to 20 MHz. Output amplitude is programmable from 20 mV to 20 V p-p from 50 Ω and dc offset is programmable from 20 mV to 7.5 V. For dc voltage applications, offset only can be programmed. Programmable waveform hold can freeze the output voltage of any 200 Hz or less waveform at its instantaneous value. Waveform complement and +/- trigger slope allow interfacing to circuits with the proper waveform phase, especially important in pulse and digital applications.

The ability to store ten front panel setups reduces GPIB programming time and enhances stand-alone bench applications. And the english-like GPIB commands reduce software development time.

FG 5010 CHARACTERISTICS

Waveform — Sine, Square and Triangle with variable Symmetry providing Pulses and Ramps.

Symmetry — 10% to 90%, 1% steps, ±2% accuracy. Range above 4 MHz is limited by 25 ns minimum triangle transition time (decreases to 50% at 20 MHz).

Frequency — Range: 0.002 Hz to 20 MHz. Accuracy: Continuous mode, ±0.1%. Trigger, Gate, Burst modes: frequency ≤200 Hz, ±0.1%; frequency >200 Hz, ±5.0%. Resolution: Continuous mode, 4 digits Trigger, Gate, Burst modes. Frequency ≤200 Hz, 4 digits. Frequency >200 Hz, 3 digits.

Amplitude — Range: 20 mV to 20 V p-p open circuit; 10 mV to 10 V p-p into 50 Ω load.

Accuracies —

| | Sine | Square | Triangle |
|--------------------|----------|-----------|-----------|
| .002 Hz to 500 kHz | ±3% | ±2% | ±2% |
| 500 kHz to 1 MHz | ±3% | +2% -3.5% | +2% -3.5% |
| 1 MHz to 5 MHz | ±3% | ±3% | +3% -5% |
| 5 MHz to 20 MHz | +5% -10% | ±5% | +5% -20% |

From +15°C to +35°C into 50 Ω load at 50% symmetry. Resolution: 20 mV from 2.02 V to 20.00 V p-p, 2 mV from 202 mV to 2.000 V p-p, 0.2 mV from 20.0 mV to 200.0 mV p-p.

Offset — Range: ±10 mV to ±7.5 V open circuit; ±5 mV to ±3.75 V into 50 Ω load. Maximum peak signal plus offset is ±15 V open circuit, ±7.5 V into 50 Ω load. Accuracy: ≤ ±1% of the selected offset, +1% of the signal p-p amplitude, +20 mV. Resolution: 10 mV open circuit, 5 mV into 50 Ω load. 0 volts is also provided.

Output Impedance — 50 Ω.

Sinewave Distortion — 20 Hz to 19.99 kHz, ≤0.5%; 20.0 kHz to 99.99 kHz, ≤1.0%; 100 kHz to 20.0 MHz, Harmonics greater than 30 dB down. Valid from +15°C to +35°C into 50 Ω load with 0 V offset, continuous mode, 50% symmetry, and AM, FM, VCF, and Complement off.

Squarewave Response — Risettime and Faltime are ≤10 ns. Aberrations are ≤5% p-p +20 mV.

Triangle Linearity (10% to 90%) — 0.002 Hz to 100 kHz, ≥99%. 100 kHz to 2 MHz, ≥98%. 2 MHz to 20 MHz, ≥90%.

Trigger Output — 0 V ±100 mV to ≥ +2 V from 50 Ω source impedance.

TRIG, GATE, BURST, and PH LOCK INPUT

Input Impedance — 1 MΩ or 50 Ω, internally selectable.

Trigger Threshold — 0 V or +0.5 V, internally selectable.

Amplitude sensitivity — ≤250 mV p-p.

Slope — Plus or Minus, plus only in PH LOCK.

Minimum Pulse Width — 25 ns.

Maximum Frequency — 20 MHz.

Maximum Input Amplitude — ±5 V pk into 50 Ω, ±20 V pk into 1 MΩ.

Burst Range — 1 to 9999 cycles.

Phase Lock Range — Automatic capture from 20 Hz to 20 MHz.

Phase Lock Time — Typically 8 ms to 88 sec, depending on final frequency and start frequency.

AM INPUT

Input Impedance — 10 kΩ.

Sensitivity — 5 V p-p produces ≥100% modulation.

Distortion — <2% at 70% modulation and ≤2 MHz; <4% at 70% modulation and >2 MHz.

Bandwidth — Dc to ≥100 kHz.

Maximum Input Amplitude — ±20 V pk.

FM INPUT

Input Impedance — 10 kΩ.

Sensitivity — 0 to ±1V deviates center frequency ≥ ±1%.

Distortion — ≤2%

Bandwidth — Dc to ≥100 kHz.

Maximum Input — ±20 V pk.

VCF INPUT

Input Impedance — 10 kΩ.

Sensitivity — 0 to 10.0 V produces a ≥1000:1 frequency change, positive going voltage increases frequency.

Slew Rate — ≥0.063 V/μs.

Bandwidth — Dc to ≥100 kHz.

Maximum Input — ±20 V pk.

OUTPUT HOLD MODE

Range — 0.002 Hz to 200 Hz. (Output holds at instantaneous value)

PHASE (TRIG, GATE, and BURST modes)

Range — ±90° to 1 MHz, decreasing to ±47° at 20 MHz.

Accuracy — ±2° to 500 kHz;

$$\pm[2^\circ + \left(\frac{\text{freq}}{20 \text{ MHz}} \times 19\% \times \beta\right)^\circ]$$

From +15°C to +35°C, VCF off, output in Normal and symmetry at 50%.

Resolution — 1°

PHASE (PH LOCK MODE)

From +15°C to +35°C.

Range — ±90° to 9.999 MHz; ±50° from 10 MHz to 20 MHz (Complementing the output extends range).

Accuracy — ± (2° + 5% of selected value).

Resolution — 1°

OTHER CHARACTERISTICS

Operating Temperature — 0°C to +50°C.

Storage Temperature — -55°C to +75°C.

Operating Altitude — 4.6 km (15,000 ft).

Storage Altitude — 15 km (50,000 ft).

Power Consumption — 60 watts.

Net Weight — 6.2 lbs.

INCLUDED ACCESSORIES

Extender Board Kit 067-0152-00, Rear Interface Signal Cable Kit 020-0701-00, Service Kit 067-1041-00.

**Order FG 5010 20 MHz
Function Generator \$5200**

FG 507

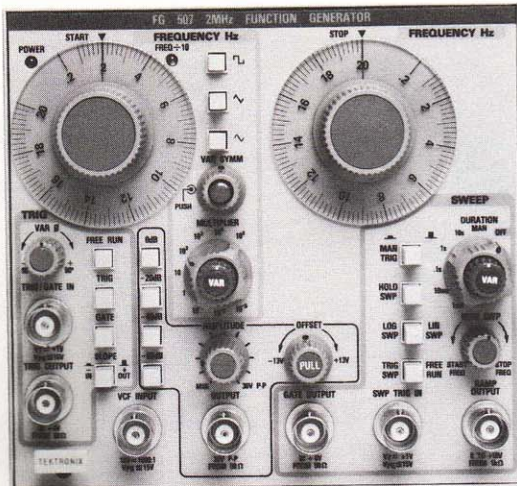

2 MHz Sweeping Function Generator

FG 507

0.002 Hz to 2 MHz

Includes all FG 501A Features

Logarithmic or Linear Sweep

Separate Start/Stop Frequency Dials

Sweep Up or Down

Sweep and Hold

Manual Sweep

The FG 507 features the same basic performance as the FG 501A and adds flexible, easy-to-use log and linear sweep capability.

The log sweep of the FG 507 is mathematically accurate and allows accurate frequency plots when using log scales, log paper, or a storage oscilloscope like the SC 503 Storage Oscilloscope. Separate start and stop frequency dials make frequency settings easy to set and interpret. The instrument can be internally or externally swept up or down and a third frequency control allows you to manually sweep between the preset start and stop frequencies without disturbing their settings. This is especially convenient for examining frequency and amplitude anomalies of a circuit under test or in setting start and stop points. The sweep generator can be swept and the sweep gate output can be used to gate (burst) the generator on for swept bursts. The sweep hold mode allows the generator to sweep to the stop frequency and remain there until released.

The accurate log/lin sweep capability of the FG 507 plus the low distortion, 0.25% over the audio range, make it ideally suited to audio testing.

Order FG 507 2 MHz Sweeping Function Generator \$1300

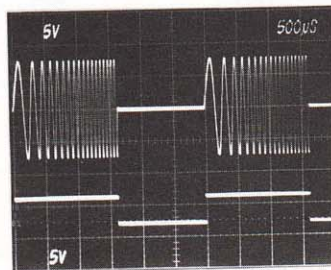

FG 507 triggered sweep mode with output gated on by sweep gate.

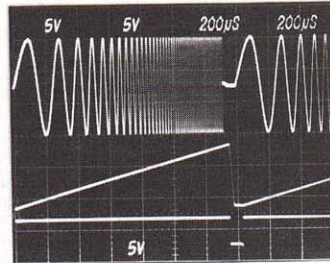

FG 507 in logarithmic sweep with sweep ramp and gate outputs.

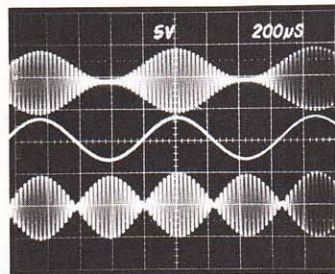

True four quadrant multiplier permits normal am or double side-band suppressed carrier modulation.

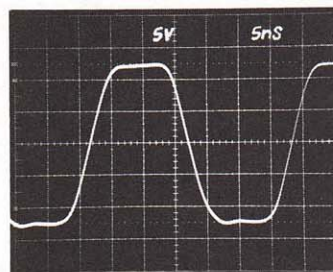

FG 504 30 volt output with 6 ns rise and fall times for superior pulse waveforms.

FG 504

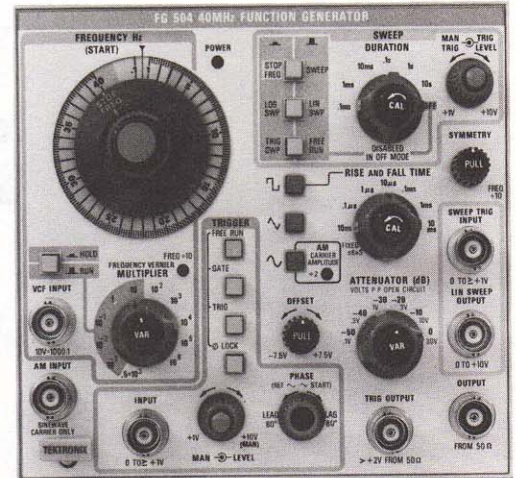

40 MHz Function Generator

FG 504

0.001 Hz to 40 MHz

Three Basic Waveforms, Plus a Wide Range of Shaping with Variable Rise and Fall Times and Symmetry Controls

Logarithmic or Linear Sweep

Separate Frequency Dials Set Lower (START) and Upper (STOP) Limits of Sweep

Up to 30 V p-p Output

Built-in Attenuator

Am and Fm

Phase Lock Mode

External and Manual Trigger or Gate

Counted Burst with DD 501

The output of the FG 504 may be phase locked, gated, or triggered by a reference signal, letting you convert from one waveform to another, such as pulses to sinewaves, as well as adjust phase relationships. Post attenuator offset enables use of the full ± 7.5 V offset range with small signals. And the FG 504 output can be amplitude or frequency modulated by external signals.

The FG 504 also provides trigger output, external voltage control input, and sweep output.

ORDERING INFORMATION
FG 504 40 MHz Function Generator .. \$2360
FG 504T 40 MHz Function Generator \$2645
 (includes FG 504, TM 503 Mainframe, and 016-0195-03 blank panel)

FG 501A

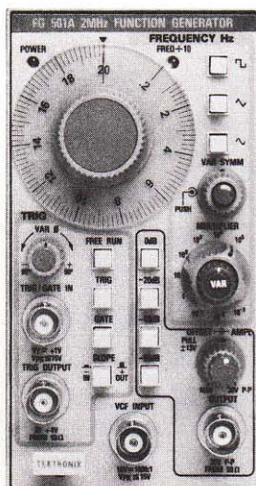

2 MHz Function Generator

FG 501A

- 0.002 Hz to 2 MHz
- 30 V p-p, ±13 V Offset
- 5% to 95% Variable Symmetry
- Trigger or Gate, ± Slope
- 60 dB Step Attenuator
- ≤0.25% Sinewave Distortion
- ≤25 ns Rise/Fall

The FG 501A provides low-distortion outputs from 0.002 Hz to 2 MHz. It is capable of generating five basic waveforms—sine wave, square wave, triangle, ramp, and pulse—at output levels up to 30 volts peak-to-peak with up to ±13 volts of offset from a 50-ohm source. Waveform triggering and gating are provided with a variable phase control to permit up to ±90° of phase shift for generating haversines, sin² pulses, and havers triangles. A step attenuator provides 60 dB of output signal attenuation in 20 dB steps with an additional 20 dB of variable attenuation. Variable symmetry from 5% to 95% provides ramps and pulses. Pulse risetime is ≤25 ns. Audio sinewave distortion is less than 0.25% and audio amplitude flatness is within 0.1 dB.

Because of its ability to generate low distortion sine waves, the FG 501A is uniquely appropriate for applications demanding audio signals.

Also useful in audio applications is the built-in 0 to 60 dB attenuator designed into the FG 501A.

The wide range variable symmetry of the FG 501A is useful for generation of pulses and ramps.

Order FG 501A 2 MHz Function Generator \$700

FG 502

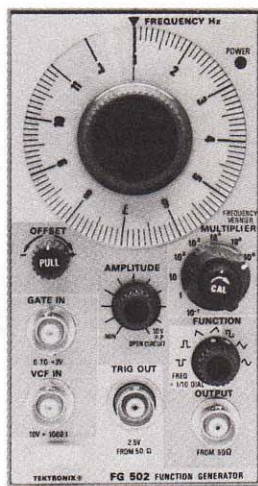

11 MHz Function Generator

FG 502

- 0.1 Hz to 11 MHz
- Five Waveforms
- Vcf and Gated Burst

The FG 502 Function Generator provides low-distortion sine, square, and triangle waveforms, and positive or negative ramps and pulses. Output frequency is continuously variable from 0.1 Hz to 11 MHz. The high frequency range from 1 to 11 MHz permits the versatility of the function generator to be extended into the medium radio frequency range. Voltage controlled frequency input permits the FG 502 to be used as a sweep generator. The external gate input permits the FG 502 output in any of its modes to be controlled by an externally supplied pulse to generate bursts of various output waveforms. This feature has application in wireline or radio remote control equipment and in certain phases of the telephone industry.

Order FG 502 11 MHz Function Generator \$810

FG 503

- 1.0 Hz to 3 MHz
- Three Waveforms

Vcf

The FG 503 Function Generator provides high-quality low-distortion sine, square, and triangle waveforms. Six decade frequency multiplier steps, a custom position for user-determined frequency multiplication, a dial calibrated from 1.0 to 30 (uncalibrated from 0.1 to 1.0), and a frequency vernier control work together to select frequencies in overlapping ranges from 1 Hz to 3 MHz. The output frequency may be swept over a 1000:1 ratio by an external voltage. Output amplitude and offset controls are provided. A trigger output is available for controlling external devices or equipment. Amplitude up to 10 V p-p can be developed across a 50 Ω load (20 V p-p open circuit). Selectable offset up to 3.75 V dc across 50 Ω (7.5 V dc open circuit) is also featured.

Order 503 3 MHz Function Generator \$525

FG 503



3 MHz Function Generator

RG 501

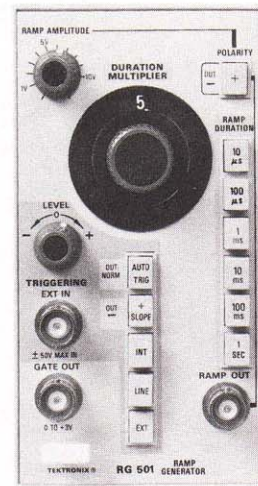

Ramp Generator

RG 501

- 10 μs to 10 s Ramp Duration
- Plus or Minus Output
- 10 V Amplitude
- Scope-type Trigger Functions
- Gate Out, TTL Compatible

RAMP

Ramp Duration — Decade ranges of 10 μs to 1 s, extends to 10 s with 1-10 duration multiplier. Accurate within 3% when multiplier is at X1 (multiplier not calibrated).

Ramp Amplitude — Continuously variable from 50 mV or less to at least 10 V, either polarity. Dc level between ramps, 0 V within 20 mV.

Gate — From a low state of 0 V, within 100 mV, the ramp gate rises to +3 V, within 0.6 V, in 100 ns or less. Fall time is 100 ns or less. Gate source impedance is nominally 160 Ω.

Ramp Output Characteristics — Minimum load resistance 3 kΩ; max load capacitance, 300 pF.

TRIGGERING

Auto Triggering — Provides free-running signal in absence of trigger. Locks automatically to trigger with a frequency above 20 Hz and at least 200 mV amplitude.

External Triggering — Sensitivity is at least 200 mV p-p, dc to 100 kHz. Input impedance ≈9.5 kΩ. 50 V (dc + peak ac) max input.

Internal Triggering — Same as external except that the trigger source is via the rear interface.

Line Trigger — Triggers at line frequency.

Trigger Level Range — ±1 V.

Order RG 501 Ramp Generator \$540

OPTIONAL ACCESSORY

Manual (one-shot) Trigger Generator (016-0597-00) \$125

The TM 500 Signal Processors offer unique capabilities for solving electrical measurement and analysis problems. Compact portability and plug-in flexibility allow complete lab instrumentation set-ups, within stringent space and budget limitations.

These versatile signal alteration devices are applicable to a broad range of measurement needs: preamplification of low level signals; addition or removal of dc offset; integration, differentiation, or summing of multiple signals; impedance transformation; or amplification (to 80 V p-p) to suggest a few.

The AM 503 is specifically designed to work with the A6303/A6302 Current Probes (up to 50 MHz), and incorporates a feature that limits the bandwidth to 5 MHz, allowing elimination of unwanted transients or noise. An illuminated knob skirt indicates calibrated current per division.

To use these current probes to their full bandwidth, the bandwidth of the oscilloscope should be greater than the probe/AM 503 combination. For example, with the A6302/AM 503, a scope such as the 80 MHz SC 504 can be used to obtain full bandwidth capability.

The A6302/AM 503 and A6303/AM 503 Current Probe Systems have a wide variety of applications from SCR and power supply measurements to medical applications. The probes utilize inductive coupling eliminating the need to break the circuit under test.

The versatile AM 502 Differential Amplifier lets you control gain, dc offset, low frequency and high frequency response for maximum rejection of unwanted signals. Adjustable dc offset allows high amplification even when low-level signals have a dc component of up to one volt. High performance features of the AM 502 are a dc to 1 MHz bandwidth and 100 dB common-mode rejection ratio.

The AM 501 Operational Amplifier's output power (± 40 volts and ± 50 mA across 800 Ω loads) is more than adequate for most electronic and electro-mechanical applications. This high-output unit has front panel connectors that let you change configurations by selecting feedback components. The AM 501 is easily set up for differentiation, integration, summing and impedance transformation problems.

Our extremely versatile AF 501 Bandpass Filter/Amplifier has a center frequency that is one-knob tunable over the entire audio range (3 Hz to 35 kHz). It's switch-selectable in broad ($Q=5$, $\approx 1/3$ octave) and narrow ($Q=15$, $\approx 1/10$ octave) bandwidths. It provides sine wave generation to 35 kHz and flat signal amplification to 50 kHz. You can select amplification from 1 to 500 in a 1-2-5 sequence in both filter and amplifier modes.

AM 503

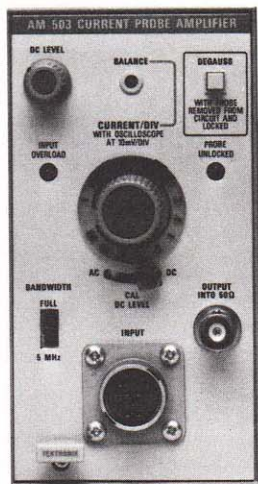

Current Probe Amplifier

AM 503

Displays Current Signals on an Oscilloscope

Current Range, Maximum Current, and Bandwidth Determined by the Probe Used

The AM 503 is a plug-in modular current-probe amplifier that operates in TM 500 Mainframes. It allows display of current on any oscilloscope with 10 mV/div sensitivity, 50 ohm or 1 megohm input, and (for performance to full bandwidth specifications) at least 75 MHz when using the A6302 or 50 MHz when using the A6303. The amplifier attenuator is calibrated in 12 steps with a 1, 2, 5 sequence, and the knob-skirt is illuminated to indicate current per division. The current range, maximum current rating, and bandwidth are determined by the particular probe in use. Bandwidth can be set to FULL (where it is limited by the probe in use) or to 5 MHz. Coupling may be switch selected to ac or dc. Ac coupling offers a convenient means of measuring low-amplitude ac signals on a high-level dc current. A front-panel indicator warns of input current overload.

CHARACTERISTICS

(AM 503 Current Probe Amplifier with A6302 Probe or A6303 Probe)

Maximum Input Current — 20 A (dc + peak ac) for A6302. 100 A (dc + peak ac) for A6303.

Maximum Voltage for Current Under Test (Bare Conductor) — 500 V (dc + peak ac) for A6302. 700 V (dc + peak ac) for A6303.

Bandwidth (-3 dB) — Dc to at least 50 MHz with A6302. Dc to at least 15 MHz with A6303.

Rise Time (Full Bandwidth) — 7 ns or less with A6302. 23 ns or less with A6303.

Deflection Factor — 1 mA/div to 5 A/div for A6302. 20 mA/div to 50 A/div for A6303. In a 1, 2, 5 sequence for both probes.

Attenuator Accuracy — Within 3% of indicated CURRENT-/DIV for both probes.

INCLUDED ACCESSORIES WITH AM 503

50 Ω cable with BNC (012-0057-01), 50 Ω terminator (011-0049-01).

Order AM 503 Current Probe Amplifier . \$875



A6303 Current Probe

100 A Ac and Dc Current Measurements

Dc to 15 MHz Bandwidth

Peak Pulse Measurements to 500 A

Ac or Dc Coupling

1 Inch by 0.830 Inch Jaw Opening

One-hand Operation

This new clamp-around probe satisfies requirements for current measurements to 100 A from dc to 15 MHz. Equipped with a convenient pistol grip, the A6303 can easily be clamped to cables up to 0.830 in. Other measurement parameters of the probe include: 100 amps continuous and 500 amps peak.

By combining an oscilloscope, like the SC 504, with the A6303/AM 503 Current Probe Amplifier in a TM 500 Mainframe you will have a convenient and compact high current amplification/measurement system.

Order A6303 Current Probe \$845



A6302 Current Probe

1 mA to 20 A Current Measurement Range

50 A Peak Pulse Measurements

Dc to 50 MHz Bandwidth

When a A6302 Current Probe is used with the AM 503 Current Probe Amplifier, the current range is from 1 mA to 20 A. Maximum current is 20 A (dc + peak ac). Peak pulse maximum is 50 A not to exceed a product of 100 A μ s. The probe operates through inductive coupling with no electrical contact. A flick of your forefinger operates the sliding jaw in the insulated probe tip. Just put the probe tip around the conductor under test for immediate current readings.

Included Accessories — 5 inch ground lead (175-0124-01), 3 inch ground lead (175-0263-01), 2 alligator clips (344-0046-00).

Order A6302 Current Probe \$440

AM 502

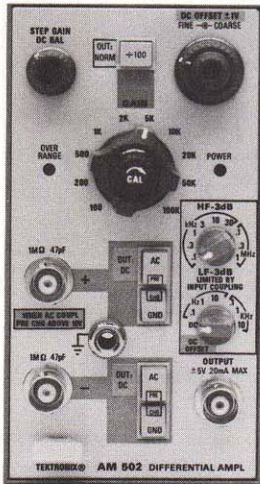

Differential Amplifier

AM 502

1 to 100,000 Gain

100 dB Cmmr

Selectable Upper and Lower -3 dB Points

Dc to 1 MHz Maximum Bandwidth

Adjustable Dc Offset

The AM 502 Differential Amplifier features wide bandwidth; high cmrr; and selectable calibrated gain and filtering. Well-suited for general-purpose or laboratory work, it can drive oscilloscopes, monitors, chart recorders, displays, or processing devices. In the unity gain mode, it can be used as a signal conditioner. Input dc offsetting to ± 1 V is provided.

AMPLIFIER

Gain — 100 to 100,000, 1-2-5 sequence, accurate within 2%. 1X gain obtained by 100X attenuation.

Hf -3 dB POINT — Selectable in 9 steps (1-3 sequence) from 100 Hz to 1 MHz. Upper -3 dB point reduces to 500 kHz at 50 k gain, 250 kHz at 100 k gain.

Lf -3 dB POINT — Selectable in 6 steps from 0.1 Hz to 10 kHz; ac coupling limits -3 dB point to 2 Hz or less.

Variable DC Offset — At least ± 1 V.

Normal-Mode Cmmr — At least 100 dB, dc to 50 kHz, ± 5 V. $\div 100$ Mode Cmmr — At least 50 dB, dc to 50 kHz, ± 10 V.

Max Input Voltage — Normal mode dc coupled: 15 V (dc + peak ac). $\div 100$ Mode dc coupled: 350 V (dc + peak ac). Ac coupled: 350 V (dc + peak ac) with coupling capacitor precharged.

Input R and C — 1 M Ω paralleled by ≈ 47 pF. Input impedance can be increased to a FET input via a simple internal jumper change.

Max Voltage Drift — 100 μ V/ $^{\circ}$ C referred to input NORM mode.

Input Gate Current — ± 100 pA for T $\leq 30^{\circ}$ C.

Max Noise — ≤ 25 μ V or less (tangentially measured) referred to input NORM mode.

OUTPUT

Max Output — ± 5 V, ± 20 mA, output resistance is 5 Ω or less.

Min Load Impedance — 250 Ω

Over Range — Front-panel lamp indicates most over-range conditions.

Order AM 502 Differential Amplifier \$1065

AM 501

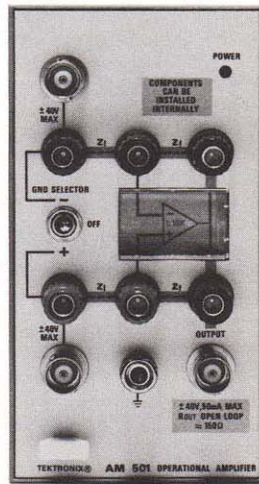

Operational Amplifier

AM 501

± 40 V, 50 mA Output

Open Loop Gain 10,000

50 V/ μ s Slew Rate

Symmetrical Differential Design

The AM 501 Operational Amplifier features high input impedance (FET), high slew rate, a wide range of input and output voltage, and high output current. Applications include: amplification; impedance transformation; integration; differentiation and summing. It is well-suited as a post-amplifier or offset-generator for signal sources, including the TM 500 Modules. Components may be added externally or internally making it ideal for teaching operational amplifier theory.

OPERATIONAL AMPLIFIER

Open Loop Gain — At least 10,000 at 60 Hz into 800 Ω load.

Unity Gain Bandwidth — At least 5 MHz into 800 Ω load.

Common-Mode Rejection Ratio — Typically $>20,000$ to 1 at 60 Hz for common-mode signals up to ± 40 V.

Slew Rate — At least 50 V/ μ s into an 800 Ω load.

INPUT

Input Bias Current — Typically <500 pA at 25 $^{\circ}$ C. <2 nA at 50 $^{\circ}$ C.

Drift — <100 μ V/ $^{\circ}$ C.

Noise — <10 μ V RMS.

Max Differential Input Voltage — 80 V.

OUTPUT

Voltage Range — At least ± 40 V into 2 k Ω .

Current Limit — At least ± 50 mA.

Open Loop Output R — ≈ 150 Ω .

Order AM 501 Operational Amplifier .. \$530

OPTIONAL ACCESSORY

Terminal Accessory Adapter Kit

(013-0146-00) \$22

AF 501

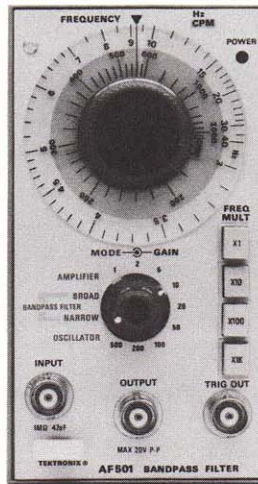

Bandpass Filter/Amplifier

AF 501

Tunable Bandpass Filtering to 35 kHz

Signal Amplification to 50 kHz

Sinewave Generation to 35 kHz

Strobe Trigger Synced to Oscillator or Filter Output

Dial Readings in Hz or Cycles per Minute

The AF 501 is a Bandpass Filter/Amplifier, ac-coupled amplifier and sinewave generator. Used alone or in conjunction with other TM 500 instruments, the AF 501 is a highly versatile and accurate signal analysis tool. Developed primarily for the mechanical measurement domain, the AF 501 can be used as a manual-sweep spectrum analyzer for complex sound and vibration signals. Single-frequency tuning facilitates isolation of 1X rpm signals in dynamic balancing, or viewing higher order disturbances on a CRT monitor. An output pulse, synced to the filter or oscillator output signal, is available for triggering a stroboscope or oscilloscope and for frequency counting.

BANDPASS FILTER

Center Frequency Range — 3 Hz to 35 kHz in 4 decade steps.

Frequency Dial Error — $<5\%$ dial setting between 3-20, $<10\%$ dial setting between 20-30.

Frequency Multiplier — X1, X10, X100, X1 k.

Phase Shift — $<10^{\circ}$ at tuned frequency below 5 kHz.

Dial Range — 3 to 40 Hz/180-2400 cpm.

Max Filter Attenuation — >70 dB.

Filter Selectivity — Broad: Q = 5 ± 1 .
Narrow: Q = 15 ± 5 .

Bandwidth at Half-power Points —
 $\Delta F - 3$ dB = $\frac{\text{center frequency}}{Q}$

Gain Range — 1-500; 1-2-5 sequence.

Gain Accuracy — ± 3 dB (Broad), ± 5 dB (Narrow).

Input Impedance — 1 M Ω $\pm 1\%$ paralleled by ≈ 47 pF.

Max Dc Input Voltage — ± 100 V.

Output Voltage — 20 V p-p (max freq times amplitude = 400 V kHz).

Output Current — 20 mA p-p max (at 20 V p-p).

Output Impedance — <1 Ω .

AMPLIFIER

Gain — 1 to 500; 1-2-5 sequence.

Gain Accuracy — $\pm 3\%$.

Bandwidth — <0.5 Hz to >50 kHz (at 3 dB point).

Input Impedance — 1 M Ω $\pm 1\%$ paralleled by ≈ 47 pF.

Noise — <25 mV rms (referred to output).

Output Voltage — 20 V p-p (max freq times amplitude = 400 V kHz).

OSCILLATOR

Sine Wave Out Range — 3 Hz to 35 kHz.

Dial Range — 3 to 40 Hz/180-2400 cpm.

Output Amplitude — 1, 2, or 5 V p-p $\pm 20\%$, depending on gain position.

Waveform Distortion — $<3\%$.

Output Current — Max 50 mA p-p.

Output Impedance — <1 Ω (within 50 mA output current limit).

TRIGGER OUTPUT

Pulse Amplitude — >10 V.

Pulse Duration — 10 ± 5 μ s.

Min Signal Required — 500 mV, p-p

Rise and Fall Time — <1 μ s.

Output Impedance — ≈ 50 Ω .

Order AF 501 Bandpass Filter/Amplifier \$840

Downtime is one problem no production manager can afford ... and the time service engineers spend transporting oscilloscopes from the job site to the calibration bench is wasted time. In the end, for a production house or manufacturing unit, the production line is the bottom line.

With the CG 551AP, Tektronix Oscilloscope Calibration Instruments come close to solving the entire range of oscilloscope calibration problems.

The CG 551AP is the computerized solution to large-scale scope calibration needs. The CG 551AP can be used as part of a computerized system to calibrate and verify all of the major oscilloscope parameters. The CG 551AP is specifically designed for use at those installations where many oscilloscopes are used and maintained. Its programmability, combined with state-of-the-art performance, helps to minimize calibration lab labor while maximizing accuracy of verification checks.

In addition to the CG 551AP, TM 500 offers a complete set of calibration instruments which can be configured into a portable test set for in-field oscilloscope service and calibration.

These TM 500 Oscilloscope Calibration instruments offer the widest range of standard amplitude square waves, fastest rise times, lowest aberrations, fastest time marks and widest frequency range of leveled sine waves available today.

In addition to its crystal-controlled mode, the TG 501 provides a variable mode. This means you can quickly adjust and accurately align the time mark spacing to your oscilloscope's graticule marks, and read the percentage timing error directly off the TG 501's digital display.

Our PG 506 Calibration Generator offers TM 500 portability plus state-of-the-art performance features. With the PG 506 in the amplitude calibration mode, you can generate a 1 kHz squarewave and vary its amplitude around the calibrated level until the squarewave aligns with your oscilloscope's vertical graticule divisions. At that point, you can read the scope deflection error right off the PG 506's digital display in percentage high or low.

TM 500 leveled sinewave generators, the SG 503 and SG 504, round out a scope calibration and verification package. These generators provide leveled sine waves for bandwidth checks (–3 dB points) and triggering performance checks.

The SG 503 is a general-purpose leveled sine-wave oscillator providing variable output from 250 kHz to 250 MHz. The SG 504 provides a leveled output amplitude that is variable from 245 MHz to 1050 MHz in two bands.

Another TM 500 plug-in, the SG 502 Oscillator, could also benefit calibration applications where verification of low frequency roll off in ac modes and performance measurement of low frequency reject triggering modes is required.

For features that allow time and error reduction for on-the-job oscilloscope evaluation, our TM 500 Calibration instruments are the best value on the market today.

Tektronix offers maintenance training classes on the TM 500 Calibration Systems Package and a new multimedia training package on Digital Counter and Meter Concepts. For TM 5000 training and other training information, contact your local Sales Office or request a copy of the Tektronix Customer Training Catalog.

OSCILLOSCOPE CALIBRATION INSTRUMENTS CHART

| | CG 551AP Programmable Calibration Generator | PG 506 Calibration Generator | TG 501 Time Mark Generator | SG 503 Signal Generator | SG 504 Signal Generator |
|----------------------------|---|--|--------------------------------------|---|---|
| Primary Functions | Amplitude Calibration 40 μ V to 200 V Time-base Calibration 400 ps to 5 s | Amplitude Calibration 200 μ V to 100 V | Time-base Calibration 1 ns to 5 s | Bandwidth Calibration 250 kHz to 250 MHz | Bandwidth Calibration 245 MHz to 1050 MHz |
| Secondary Functions | Rise time and transient response testing, attenuator compensation testing, Testing oscilloscope nonlinearity. | Rise time and transient response testing, attenuator compensation testing. | Testing oscilloscope nonlinearity | General leveled rf signal source | General leveled rf signal source with frequency modulation capability |

CG 551AP

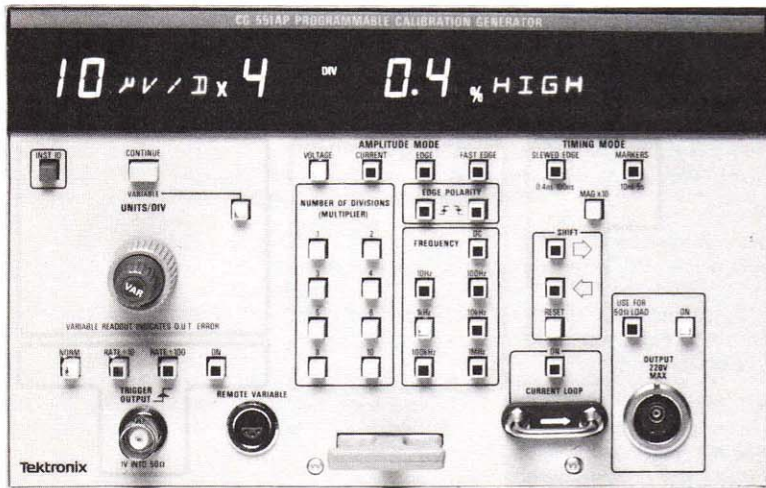

Programmable Oscilloscope Calibration Generator

CG 551AP

GPIB
IEEE-488

The CG 551AP is designed to comply with IEEE Standard 488-1978, and with Tektronix Codes and Formats Standard.

The TEKTRONIX CG 551AP is a microprocessor-based oscilloscope calibration generator that is fully programmable. It can be used as part of a computerized system for the calibration and verification of major oscilloscope parameters, including:

- Vertical Gain
- Horizontal Timing and Gain
- Vertical Bandwidth/ Pulse Characteristics
- Probe Accuracy and Compensation
- Current Probe Accuracy
- Calibrator Output Accuracy

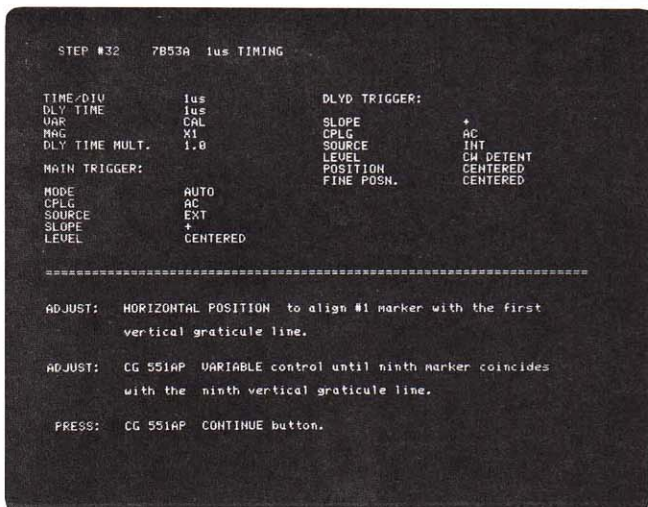

Instructions to operator on CRT screen of 4052 Graphics Computing Controller.

tion signals to the oscilloscope. At the same time, a series of operator instructions on the CRT are automatically coordinated with the calibration signals going into the oscilloscope from the CG 551AP. The operator follows these instructions to make the necessary settings of the oscilloscope controls as the calibration or test procedure progresses. The CG 551AP return error or deviation information to the controller, where it is compared with preprogrammed reference values for the oscilloscope; out-of-tolerance values are flagged. A permanent record of the entire maintenance procedure can be stored by the controller and can be printed via peripherals such as the hard copy unit or line printer. Throughout the process, all calibration settings are determined by the computer's program. All front panel settings on the oscilloscope are specified in detail for the operator. Calculations of error percentages are performed automatically.

To develop the specific software for testing and calibration of different oscilloscopes, Tektronix has designed the CG 551AP ScopeCal Procedure Development Aid program. This program assumes you are not familiar with programming. To incorporate the calibrator's knowledge into the system software, the ScopeCal Procedure Development Aid program uses two simplified techniques. First is a series of questions that appear on the controller's CRT. The calibrator's answers to these questions form the foundation for the software that will eventually run the system. Second is the CG 551AP's "LEARN" mode, which allows the calibrator to set functions and ranges using the CG 551AP's front panel controls (as would have been done on older generations of manually-operated calibration generators), and have these entries automatically transferred to the controller for use in forming the program. Once the calibrator has completed interacting with the ScopeCal Procedure Development Aid program, all the acquired information is automatically converted into a simpler program format that will govern the system's operation when a less experienced operator is using it. This operator-oriented program will take care of all the CG 551AP's settings, while giving the operator a

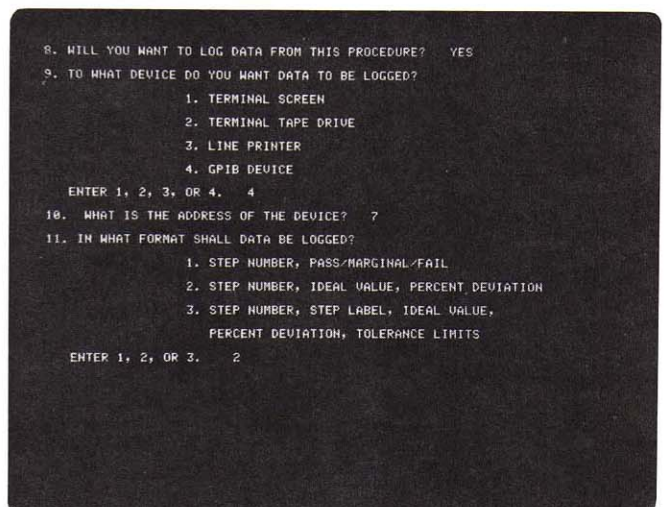

4052 Graphics Computer Controller showing the development of a typical calibration procedure using the ScopeCal Procedure Development Aid program.

step-by-step description of any settings that must be made on the oscilloscope. It will also accept data from the CG 551AP or the controller keyboard.

The CG 551AP is designed to greatly reduce your maintenance costs. Built-in self test routines and hardware check the operation of all major circuits each time the power is turned on.

Modular construction means that all circuit boards unplug (except the Main Interconnect) for easy exchange if service is required. A signature analysis mode is included to facilitate troubleshooting of the digital portion of the instrument.

VOLTAGE (AMPLITUDE MODE)

The standard voltage is used to calibrate vertical display accuracy.

Range — 40 μ V to 200 V (1-2-5 steps with multiplier).

Multipliers — 1,2,3,4,5,6,8,10 divisions.

Polarity — Positive from ground.

Accuracy — $\pm 0.25\% \pm 1 \mu$ V.

Frequency — 40 μ V to 80 mV; 10 Hz to 100 kHz, 100mV to 10 V; 10 Hz to 100 kHz, or dc. 12 V to 200 V; 10 Hz to 10 kHz, or dc.

Droop — $\leq 1\%$.

Variable Range — $\pm 9.9\%$.

CURRENT (AMPLITUDE MODE)

The standard current is used to calibrate current probes.

Range — 1 mA to 100 mA (1-2-5 sequence).

Multipliers — 1,2,3,4,5,6,8,10.

Accuracy — $\pm 0.25\% \pm 2 \mu$ A.

Frequency — Dc or 10 Hz to 1 MHz (decade steps).

Droop — $\leq 1\%$.

Variable Range — $\pm 9.9\%$.

LOW EDGE (AMPLITUDE MODE)

The Low Distortion Pulse obtained in this mode is used to test oscilloscope input amplifier and attenuator compensation.

Range — 20 mV to 1 V (1-2-5 steps with multipliers).

Multipliers — 1,2,3,4,5,6,8,10.

Polarity — Positive or negative transitions to ground.

Risetime (Falltime) — < 1.3 ns.

Aberrations — $\pm 2\%$.

Long Term Flatness — $\pm 0.5\%$ after first 10 ns.

Frequency — 10 Hz to 1 MHz (decade steps).

Variable Amplitude Range — $> \pm 10\%$ from nominal.

Termination — 50 Ω .

HIGH EDGE (AMPLITUDE MODE)

The Low Distortion Pulse obtained in this mode is used to test oscilloscope input amplifier and attenuator compensation.

Range — 1.2 V to 100 V (1-2-5 steps with multipliers).

Polarity — Positive to ground.

Risetime — < 100 ps.

Aberrations — $\pm 2\%$.

Long Term Flatness — $\pm 0.5\%$ after first 500 ns.

Frequency — 10 Hz to 100 kHz (decade steps).

Variable Amplitude Range — $> \pm 10\%$ from nominal.

Termination — ≥ 10 k Ω .

MARKERS (TIMING MODE)

The markers obtained in this mode are used to calibrate oscilloscope time bases.

Range — 10 ns to 5 s (1-2-5 steps).

X10 Magnifier — Increase marker rate by a factor of ten (0.1 μ s to 5 s range).

Accuracy — $\pm 0.01\%$ (optional TCXO $\pm 0.0003\%$).

Amplitude — 1 V minimum into 50 Ω .

Variable Range — $\pm 9.9\%$.

SLEWED EDGE (TIMING MODE)

Slewed Edges are used to calibrate the very fastest ranges found on oscilloscope time bases.

Range — 0.4 ns to 100 ns (1-2-5 steps plus 0.4 ns).

X10 Magnifier — Increases Slewed Edge rate by a factor of ten (5 ns to 100 ns range).

Accuracy — $\pm 0.01\%$ (Optional TCXO $\pm 0.0003\%$).

Edge Position Uncertainty — ± 40 ps.

Amplitude — > 1 V into 50 Ω .

Variable Range — $\pm 9.9\%$.

TRIGGER OUTPUT

The oscilloscope under test is normally triggered externally from this source.

Output Amplitude — 1 V minimum into 50 Ω .

Trigger Rate — Marker Mode

Normal — Slaved to marker rate from 100 ns to 5 s; remains at 100 ns for faster markers.

Divided by 10 — Reduces normal trigger rate by a factor of ten.

Divided by 100 — Reduces normal trigger rate by a factor of one hundred.

Slewed Edge Mode — One trigger per slewed edge. (Rate $\div 10$ and $\div 100$ not available).

All Other Modes —

Normal — Slaved to output frequency.

Divided by 10 — One-tenth output frequency.

Divided by 100 — One-hundredth output frequency.

TIMING REFERENCE OUTPUT EXTERNAL TIMING REFERENCE

Input Frequency — Any integral multiple of 1 MHz up to 5 MHz.

Required Accuracy — $\pm 0.001\%$.

Input Amplitude — 1 V to 10 V RMS.

Input Resistance — 10 k Ω (nominal).

ENVIRONMENTAL

Meets or exceeds MIL-T-28800B, Class 5 requirements.

Temperature — Operating — 0°C to +50°C.

Nonoperating — -20°C to +65°C.

Relative Humidity — 90 to 95% at +50°C for 5 days.

Altitude —

Operating — 15,000 ft (4.5 km). Nonoperating — 50,000 ft (15 km).

Vibration — Operating — Displacement (peak-to-peak), 0.015 inch. Vibration Frequency, 10 Hz - 55 Hz. Total time, 75 minutes.

Shock — Nonoperating — 30 g's, 1/2 sine, 11 ms duration, 3 shocks in each direction along 3 major axes; total shocks, 18.

Bench Handling — Operating — 45°, 4 inches or point of balance, whichever occurs first.

PHYSICAL CHARACTERISTICS

Maximum Overall Dimensions (triple compartment TM 500 Plug-in).

Height — 4.97 inches (12.63 cm).

Width — 7.96 inches (20.22).

Length — 11.97 inches (30.42 cm).

Net Weight —

Standard Instrument — 8.50 lbs (3.86 kg).

Option 01 — 8.75 lbs (3.98 kg).

PULSE HEAD (Standard Accessory)

FAST EDGE (AMPLITUDE MODE)

The Pulse Head is used to generate fast rise, low distortion pulses for testing higher bandwidth vertical amplifiers.

Amplitude — 1.1 V peak $\pm 5\%$ into 50 Ω .

Adjustable Range — $\pm 10\%$.

Risetime — ≤ 200 ps.

Polarity — Positive or negative from ground.

Aberrations — $\pm 3\%$ of pulse amplitude; not to exceed 4% p-p for adjacent peaks.

Frequency — 100 Hz to 100 kHz (decade steps).

REMOTE VARIABLE HEAD (Optional Accessory)

The Remote Variable Head permits the operator to concentrate on the oscilloscope CRT while remotely operating the following front panel controls: UNITS/DIV control; VARIABLE-FIXED button; CONTINUE pushbutton and the VAR control.

COMPARATOR HEAD (Optional Accessory)

The Comparator Head is used to calibrate built-in oscilloscope calibrators against the signals available from the CG 551AP.

Both the oscilloscope calibrator and CG 551AP standard amplitude signals are applied to the Comparator Head and simultaneously displayed on the oscilloscope CRT. The CG 551AP signals are then varied to obtain congruent displays. Errors are then displayed on the CG 551AP readout.

Input — Ac Voltage — $\pm 40 \mu$ V to ± 100 V.

Signal Frequency — 10 Hz to 1 MHz squarewave.

Dc Voltage — ± 100 mV to ± 100 V.

Resistance — Open — Unterminated (the resistance of the oscilloscope input). 50 Ω — 50 $\Omega \pm 1\%$ in 50 Ω position. Maximum voltage is ± 5 V peak in the 50 Ω position.

Chop Parameters — Frequency — 30 Hz nominal. (Auto). Auto Timeout — Internally selectable. 0.5, 1 or 2 minutes.

INCLUDED ACCESSORIES

Output Cable Assembly, 012-0884-00, Pulse Head, 015-0311-01.

MAINFRAMES

Requires TM 5003 or TM 5006.

ORDERING INFORMATION

| | |
|---|-----------------|
| CG 551AP | \$12,000 |
| Option 01 Adds High Accuracy Time Base (TCXO) | Add \$500 |
| Option 02 Deletes Pulse Head | Sub \$1100 |

OPTIONAL ACCESSORIES

| | |
|--|------------------|
| Comparator Head, Order 015-0310-01 | \$23 |
| Remote Variable, Order 015-0309-01 | \$375 |
| Pulse Head, Order 015-0311-01 | \$1400 |
| (When purchased separately.) | |
| 4052 Graphics Computing Controller (32k bytes memory) (see page 80) | \$9900 |
| Option 10 Printer Interface | Add \$550 |
| Blank 4052 Tape, Order 119-0680-01 — (box of 5) ... | \$150 |
| 119-0680-00 (One each) | \$40 |
| 4632 Hard Copy Unit (See page 90) | \$5575 |
| Option 01 Copy Counter | Add \$100 |
| Paper, Carton of four rolls, Order 006-1603-01 | \$250 |
| 4642 Matrix Printer (see page 92) | \$2900 |
| Option 01 Rear Feed Tractor Assembly | Add \$280 |
| Paper, Carton of 2,500 sheets, Order 002-0262-01 | \$45 |
| GPIB Cable, 2 meter Cable, Order 012-0630-01 | \$75 |
| SCPDA I (ScopeCal Procedure Development Aid and 465B Verification Program) | \$1450 |
| Rigid Circuit Board Extender Order 067-0975-00 | \$65 |
| Flexible Circuit Board Extender Order 067-0974-00 | \$80 |

PG 506

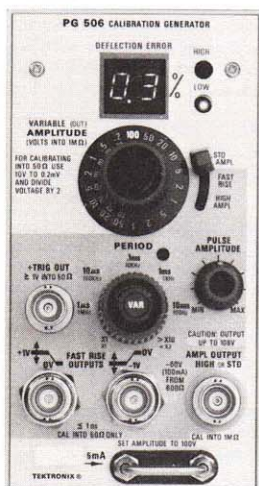

Calibration Generator

PG 506

Three Square-Wave Output Modes

10 Hz to 1 MHz

Direct Readout of Oscilloscope Deflection Error

The PG 506 is a calibration generator for oscilloscopes with three modes of squarewave output, selectable dc outputs, and a variable-amplitude output with front-panel digital indication of oscilloscope deflection error. For checking attenuator performance and transient response of oscilloscopes, simultaneous plus and minus low-level, fast rise (1.0 ns) square waves or high amplitude (60 V), extremely clean square waves are available at frequencies from 10 Hz through 1 MHz. A 5 mA calibration current loop is useful for current probe calibration. In the amplitude calibration mode, a 1 kHz square wave is generated whose amplitude may be varied around the calibrated level until the square wave aligns with the oscilloscope vertical graticule divisions; scope deflection error is then read directly off the PG 506 digital display in percentage high or low, permitting rapid verification of oscilloscope performance.

AMPLITUDE CALIBRATOR MODE

Period — Fixed at ≈ 1 ms or dc.

Amplitude — From 100 V p-p to 200 μ V p-p in 1-2-5 sequence, accurate within $\pm 0.25\%$ into 1 M Ω . 5 V p-p to 100 μ V p-p into 50 Ω .

Error Readout Range — $\pm 7.5\%$.

Error Readout Resolution — 0.1%.

PULSE MODES

Period — 1 μ s to 10 ms (within 5%) in decade steps with the VARIABLE control in CAL position. VARIABLE extends period to at least 100 ms.

Symmetry — $\approx 50\%$ duty cycle.

HIGH AMPLITUDE OUTPUT

Rise Time — Unterminated: 100 ns or less. Terminated into 50 Ω : 10 ns or less.

Amplitude Range — Unterminated: 6 V or less to at least 60 V. Terminated into 50 Ω : 0.5 V or less to at least 5 V.

Leading Edge Aberrations — Within 2% or 50 mV p-p, whichever is greater, when terminated into 50 Ω .

Polarity — Positive going from a negative potential to ground.

Output Resistance Source — 600 Ω within 5%.

FAST RISE OUTPUTS

Rise Time (Terminated into 50 Ω) — 1.0 ns or less.

Amplitude Range (Terminated into 50 Ω) — 100 mV or less to at least 1.0 V.

Leading Edge Aberrations — Within 2% or 10 mV p-p, whichever is greater, during first 10 ns.

Flatness — Within 0.5% after first 10 ns.

Polarity — Simultaneous positive and negative going. Positive going is from a negative rest potential to ground. Negative going is from a positive rest potential to ground.

Output Resistance Source — 50 Ω within 3% at + and - output connectors.

Trigger Output (Terminated into 50 Ω) — Positive-going signal of at least 1 V.

Order PG 506 Calibration Generator . \$2250

TUNNEL DIODE PULSER

The Tunnel Diode Pulser (067-0681-01) provides a clean, fast-rise pulse for adjusting the transient response of high-frequency oscilloscopes and other instruments. The Tunnel Diode Pulser can be driven by the PG 506 Calibration Generator at repetition rates exceeding 50 Hz. Output amplitude of the pulse is approximately 250 mV into 50 Ω , while rise time is ≤ 125 ps; aberrations are $< 1\%$ in a 1 GHz system.

Order 067-0681-01 \$155

PRECISION VOLTAGE DIVIDER

Designed for use with the PG 506 in the STANDARD AMPLITUDE mode, this 0.4 divider allows your oscilloscope to display a constant 4 divisions when checking amplitude calibration from 20 μ V/div through 1 V/div. It also allows the PG 506 to be more conveniently used with oscilloscopes that cannot display 5 divisions of amplitude.

Input Z — 50 Ω with output load ≥ 100 k Ω .

Max Input — ≤ 5 B RMS.

Output — 0.4 x PG 506 amplitude.

Voltage Accuracy — $\pm 0.4\%$.

Order 015-0265-00 \$115

TG 501



Time Mark Generator

TG 501

Marker Outputs, 5 s to 1 ns

Direct Readout of Oscilloscope Timing Error

External Trigger Output

The TG 501 Time Mark Generator provides marker outputs from five seconds to one nanosecond. A unique feature on the TG 501 is a variable timing output with a front-panel two digit LED display which indicates percentage of timing error between the normal time interval and a variable interval set to line up the marker pulse with graticule or division mark on the display. This feature not only provides direct readout in terms of percent error, but also helps eliminate errors associated with visually estimating error from a display.

Markers — 1 ns through 5 s in a 1-2-5 sequence.

Marker Amplitude — ≥ 1 V peak into 50 Ω on 5 s through 10 ns markers. ≥ 750 mV p-p into 50 Ω on 5 ns and 2 ns markers. ≥ 200 mV p-p into 50 Ω on 1 ns markers.

Trigger Output Signal — Slaved to marker output from 5 s through 100 ns. Remains at 100 ns for all faster markers.

| Internal Time Base | Standard | Option 01 |
|--|--|---|
| Crystal Frequency | 1 MHz | 5MHz |
| Stability (0° to 50° C) after 1/2 hour | within 1 part in 10 ⁵ | within 5 parts in 10 ⁷ |
| Long-term Drift | 1 part or less in 10 ⁵ per month | 1 part or less in 10 ⁷ per month |
| Setability | adjustable to within 1 part in 10 ⁷ | adjustable to within 5 parts in 10 ⁹ |

External Reference Input — Available with internal changes. Acceptable frequencies, 1 MHz, 5 MHz, or 10 MHz. Input amplitude must be TTL compatible.

Timing Error Readout Range — To $\pm 7.5\%$.

Timing Error Measurement Accuracy — Device under test error is indicated to within one least significant digit (to within one displayed count).

ORDERING INFORMATION

TG 501 Time Mark Generator \$1810
Option 01, 5 MHz Time Base Add \$200

SG 504

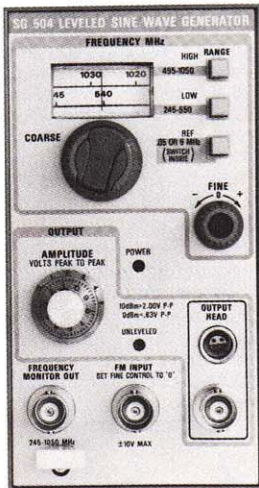

Signal Generator

SG 504

Leveled, Variable Output

245 MHz to 1050 MHz

Frequency Modulation Capability

The SG 504 Signal Generator provides a leveled output amplitude that is variable from 245 MHz to 1050 MHz in two bands. Frequency is indicated by a high-resolution tape dial that expands each band over 28 inches. The accurately calibrated output voltage is variable from 0.5 V to at least 4.0 V peak-to-peak into 50 Ω .

Frequency Range — Low band: 245 MHz to 550 MHz High-band: 495 MHz to 1050 MHz, plus 50 kHz or 6 MHz reference frequency (internally selected).

Frequency Accuracy — $\pm 2\%$ of dial indication.

Amplitude Range — 0.5 V to at least 4.0 V p-p.

Amplitude Accuracy — (at reference) Within 3% of indicated amplitude.

Flatness — $\pm 4\%$ of amplitude at reference frequency.

Harmonic Content — 2nd harmonic at least 25 dB down; 3rd and all higher at least 40 dB down.

Fm Input — Frequency range: dc to 100 kHz. Deviation sensitivity: ± 9 V produces from $\pm 0.05\%$ to $\pm 0.4\%$ deviation of carrier, depending on output frequency.

Frequency Monitor Output — ≥ 0.3 V p-p into a 50 Ω load from 245 MHz to 1050 MHz.

Rear Card Edge Connections — Address fm input, frequency monitor output, and amplitude control.



ORDERING INFORMATION

| | |
|--|--------|
| SG 504 Signal Generator (Includes Leveling Head) | \$3030 |
| Replacement Leveling Head, (015-0282-00) | \$375 |

SG 503

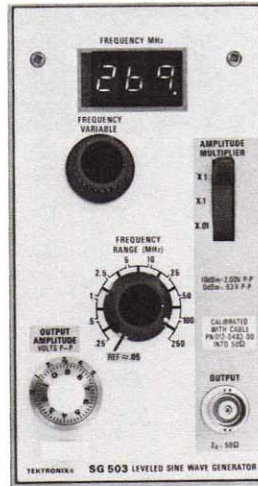

Signal Generator

SG 503

Leveled, Variable Output

250 kHz to 250 MHz

Digital Readout of Frequency

The SG 503 Signal Generator is a general-purpose leveled sine-wave oscillator. It provides a leveled output amplitude which is variable from 250 kHz to 250 MHz. The selected frequency is indicated by a built-in autoranging frequency counter with a three-digit LED read-out on the front panel. Accurately calibrated output voltage into 50 Ω is variable from 5 mV to 5.5 V peak-to-peak.

Frequency Range — 250 kHz to 250 MHz, plus 50 kHz reference frequency.

Accuracy — Within ± 0.7 of least significant digit of indicated frequency.

Amplitude Range — 5 mV to 5.5 V p-p into 50 Ω termination in three decade ranges.

Amplitude Accuracy — (50 kHz reference) Within 3% of indicated amplitude on (X1) range, 4% on (X0.1) range, and 5% on (X0.01) range.

Flatness — (p-p) From 250 kHz to 100 MHz, output amplitude will not vary more than 1% of the value at 50 kHz except that up to +1.5%, -1% variation may occur between 50 MHz and 100 MHz on amplitude multiplier X0.1 and X0.01 ranges only. From 100 MHz to 250 MHz, amplitude variation is within 3% of the value at 50 kHz.

Harmonic Content — Second harmonic at least 35 dB down. Third and all higher harmonics at least 40 dB down.

Other — Rear edge card connection available to address the leveling circuit.

Standard Accessory — Precision 50 Ω cable 3 ft long. (012-0482-00).

Order SG 503 Signal Generator \$1780

Tektronix offers maintenance training classes on the TM 500 Calibration Systems Package and a new multimedia training package on Digital Counter and Meter Concepts. For TM 5000 training and other training information, contact your local Sales Office or request a copy of the Tektronix Customer Training Catalog.

SG 502



Oscillator

SG 502

5 Hz to 500 kHz Sine and Square Waves

Low Distortion Sine Wave

5 V RMS Open Circuit—600 Ω Source

0-40 dB Output Variable Plus 0-70 dB in 10 dB Steps

The SG 502 Oscillator features a wide frequency range of 5 Hz to 500 kHz with low distortion (0.035% between 20 Hz and 50 kHz) and is desirable for general test purposes where the extremely low distortion levels of the SG 505 are not required. Other SG 502 features include 70 dB amplitude control plus a simultaneous fixed amplitude squarewave.

SINEWAVE

Frequency Range — 5 Hz to 500 kHz in 5 decade steps. Accurate within 5% of dial setting from 5 Hz to <50 kHz; within 10% of dial setting from 50 kHz to 500 kHz.

Amplitude Response — Flatness is 0.3 dB over entire range (1 kHz reference).

Attenuation — Selectable from 0 dB to 70 dB in 10, 20, and 40 dB steps with pushbuttons. Accurate within 0.2 dB for each step selected, additive. An uncalibrated control provides continuous variation from 0 dB to -40 dB.

Harmonic Distortion — <0.035% (-70 dB) from 20 Hz to 50 kHz. <0.15% from 50 kHz to 500 kHz ($R_L \geq 600 \Omega$).

Max Output Voltage — 5 V RMS open circuit; 2.5 V RMS into 600 Ω .

Output Impedance — 600 Ω , grounded.

SQUAREWAVE

Frequency Range — Same as sinewave. The squarewave switches on the 0° phase of sine out.

Rise and Fall Time — 50 ns or less.

Amplitude — +5 V, fixed, open circuit.

Output Impedance — 600 Ω , grounded.

SYNC INPUT

Oscillator can be synchronized to external signal. Sync range, the difference between sync frequency and set frequency, is a linear function of sync voltage.

Input impedance — 10 k Ω .

Order SG 502 Oscillator \$730

AA 501

Distortion Analyzer

Fully Automatic: No Level Setting, Tuning or Nulling

Total System Harmonic Distortion plus Noise (THD + N) — 0.0025%

Extremely Low Residual Noise — $< 3 \mu\text{V}$

Novel Analog-like "bar graph" plus Complete Digital Readout

True RMS or Average Responding in All Modes

Intermodulation Distortion (option) to SMPTE, DIN, and CCIF

Differential Input

Used together, the AA 501 Distortion Analyzer and SG 505 Oscillator provide the easiest solution to your distortion measurement needs. The AA 501 and SG 505 combination permits harmonic distortion, intermodulation distortion, frequency response, gain/ loss, and signal-to-noise ratio measurements to be accomplished with minimal operator skill level. At the same time, both instruments feature state-of-the-art performance in residual noise and distortion.

When using the TEKTRONIX AA 501 Distortion Analyzer and SG 505 Oscillator, complex distortion measurements become a totally automated process. All steps which previously required several minutes of skilled operator time, such as level setting, tuning and nulling are now done quickly, precisely, and automatically by the AA 501's internal circuitry.

Because the AA 501 Distortion Analyzer and SG 505 Oscillator are two separate plug-ins they may be used as a powerful package in the same mainframe or apart. For instance, the SG 505 can be left in a rackmount mainframe at a broadcast station while the AA 501 is transferred to a portable mainframe and taken to the transmitter site for distortion measurements. Together or thousands of miles apart, the AA 501 Distortion Analyzer automatically tunes to the oscillator's (SG 505 or your present oscillator) signal with no operator assistance required. The SG 505's frequency or level can be changed repeatedly and the AA 501 will automatically accommodate these changes as they occur.

The AA 501 Distortion Analyzer makes complex measurements easier than ever with no compromise in performance. The AA 501 measures total harmonic distortion, gain/loss, signal to noise ratio, and audio levels. With Option 01 the ability to measure intermodulation distortion is added. These measurements are accomplished automatically, with no level setting, nulling, or meter ranging to be done by the operator. The measurement result appears on an LED display with no additional scale factoring necessary.

AA 501

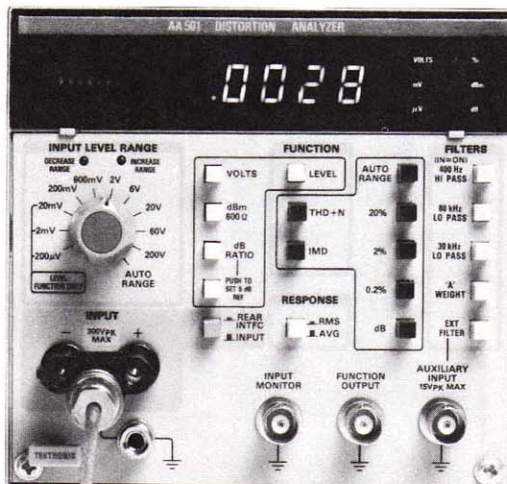

Distortion Analyzer

Residual distortion, when used with the SG 505, is 0.0025%. Residual noise in the analyzer is less than $3 \mu\text{V}$.

To measure Total Harmonic Distortion plus noise (THD+N) or Intermodulation Distortion (IMD) the operator simply feeds the audio signal to the analyzer. The AA 501 automatically locks on the signal, sets the proper level, and switches in the proper filter. In the THD+N measurement the filter nulling is totally automatic, with no presetting of controls required. When used with a separate oscillator, no loss of automatic features is experienced.

The optional IMD mode measures signals to any of three usual standards: SMPTE, DIN, or CCIF. Internal circuitry identifies the standard being used and configures itself to display the appropriate results.

The AA 501 has a 0 dB reference memory. This feature allows an audio level to be set to 0 dB and all subsequent signal levels are compared to it. The result is expressed in dB on the display.

Selection from the front panel allows readings to be expressed in true RMS or average response, RMS calibrated. Although true RMS is more accurate in most applications, the average response permits comparisons with measurements previously taken with older instrumentation.

The digital voltmeter is auto ranging on all scales, from the lowest, $200 \mu\text{V}$ full scale, to the highest, 200 V full scale.

Four filters are included and can be switched in and out from the front panel. They are: 400 Hz high pass, 30 kHz low pass, 80 kHz low pass (all 18 dB per octave Butterworth), and "A" weighting. For user convenience, an extra position on the filter switch provides for an external, user provided filter.

The AA 501 and SG 505 can be configured with several other audio-quality instruments from Tektronix. For instance, the FG 507 Sweeping Function Generator features a low distortion sine wave output (up to 2 MHz) and a log/lin sweep making it an ideal signal source in a communications test set. The FG 501A 2 MHz Function Generator is specifically designed for those audio/communications measurements not demanding log/lin sweep capability. (See pages 25, 26 for complete specifications and information on the FG 507 and FG 501A).

To complete an audio test set add the DM 502A Digital Multimeter with an accuracy of 0.1% dc volts and seven functions including autoranging dB and temperature (see page 6). The SC 503 Storage Oscilloscope is also ideal for audio/communications applications with a bandwidth of 10 MHz and X-Y capability. Storage permits slow audio sweeps to be displayed or enables the long term monitoring of peak audio levels (see page 37).

THD

Completely automatic Total Harmonic Distortion (THD) measurements to specified accuracy in 7 seconds or less.

LEVEL

Autoranging digital voltmeter displays input signal level in volts, dBm, or dB ratios.

IMD (OPTION 01)

Fully automatic SMPTE, DIN, and CCIF difference frequency test measurements.

DISTORTION FUNCTION

Fundamental Frequency Range — 10 Hz to 100 kHz automatically tuned to input frequency.

Distortion Ranges — Auto (100%), 20%, 2%, 0.2%, and dB (autoranging).

Accuracy (readings $\geq 4\%$ of range) — 20 Hz to 20 kHz ± 1 dB. 10 Hz to 100 kHz $+1, -3$ dB. (Accuracy is limited by residual THD+N and filter selection.)

AA 501/SG 505 System Residual THD+N — $V_{in} \geq 250$ mV, (all distortion, noise, and nulling error sources combined).

- 20 Hz to 20 kHz
- $\leq 0.0025\%$ (-92 dB) Average Response with 80 kHz filter.
- $\leq 0.0032\%$ (-90 dB) RMS Response with 80 kHz filter.
- 10 Hz to 50 kHz
- $\leq 0.0071\%$ (-83 dB) RMS or Average Response.
- 50 kHz to 100 kHz
- $\leq 0.010\%$ (-80 dB) RMS or Average Response.

TYPICAL THD+N

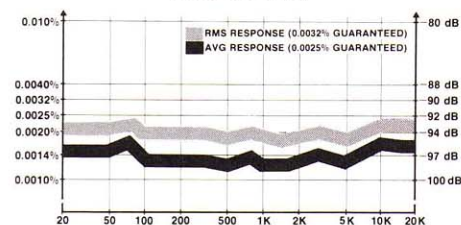

Typical Fundamental Rejection — At least 10 dB below specified residual THD+N or actual signal THD, whichever is greater.

Minimum Input Level — 60 mV (-22 dBm).

LEVEL FUNCTION

Modes — Volts, dBm (600 Ω), or dB ratio with push to set zero dB reference.

Level Ranges — 200 μV full scale to 200 V full scale in ten steps, manual or autoranging.

Accuracy —

| Frequency | Volts | dBm or dB ratio |
|-------------------|-------|-----------------|
| 20 Hz to 20 kHz | ±2% | ±0.3 dB |
| 10 Hz to 100 kHz* | ±4% | ±0.5 dB |

(Vin ≥ 100 μV, level ranging indicators extinguished).

Bandwidth — ≥300 kHz.

Residual Noise — ≤3.0 μV (−108 dBm) with 80 kHz and 400 Hz filters.

≤1.5 μV (−114 dBm) with "A" weighting filter.

*On the 200 μV range, accuracy above 50 kHz is +4%, −6% (+0.5 dB, −0.7 dB).

INTERMODULATION DISTORTION FUNCTION (OPTION 01)

SMPTE and DIN Tests — Lower frequency range: 50 Hz to 250 Hz.

Upper frequency range: 3 kHz to 100 kHz.

Level ratio range: 1:1 to 5:1 (lower:upper).

Residual IMD: ≤0.0025% (−92 dB) for 60 Hz and 7 kHz or 250 Hz and 8 kHz, 4:1 level ratio.

CCIF Difference Frequency — Frequency range: 4 kHz to 100 kHz.

Difference frequency range: 50 Hz to 1 kHz.

Residual IMD: ≤0.0018% (−95 dB) with 14 kHz and 15 kHz.

Minimum input level: 60 mV (−22 dBm).

Accuracy — ±1 dB.

ALL FUNCTIONS

Filters — 400 Hz high pass: −3 dB at 400 Hz ±5%; at least −40 dB rejection at 60 Hz.

80 kHz low pass: −3 dB at 80 kHz ±5%.

30 kHz low pass: −3 dB at 30 kHz ±5%.

"A" weighting: Meets specifications for Type 1 sound level meters (ANSI S 1.4, IEC Recommendation 179).

EXT: Allows connection of external filters.

Input Impedance — 100 kΩ ±2%, each side to ground, fully differential.

Maximum Input — 300 V pk, 200 V RMS either side to ground or differentially.

Fully protected on all ranges.

Common Mode Rejection — ≥50 dB at 50 or 60 Hz.

Typically ≥40 dB to 300 kHz.

Detection — Average or true RMS for waveforms with crest factors ≤3.

FRONT PANEL SIGNALS

Input Monitor — Provides constant amplitude version of signal applied to input. Output voltage: 1 V RMS ±10% for input signals >50 mV. Source impedance: 1 kΩ ±5%.

Function Output — Provides a scaled sample of selected function signal (1000 count display = 1 V RMS ±3%). Source impedance: 1 kΩ ±5%.

Auxiliary Input — Provides input to detector circuit when EXT FILTER button is depressed. Sensitivity: 1 V RMS ±3% = 1000 count display. Impedance: 100 kΩ ±5%, ac coupled.

REAR INTERFACE SIGNALS

Rear INTFC INPUT — Front panel selected. Same as main INPUT except, maximum signal input is limited to 42 V pk, 30 V RMS. (Potential crosstalk at rear interface may degrade noise and distortion on performance).

Monitor — Same as front panel INPUT MONITOR.

Function Output — Same as front panel FUNCTION OUTPUT.

Auxiliary Input — Same as front panel AUXILIARY INPUT.

Converter Output — DC output of selected response converter. 1 V ±5% for 1000 count display. Source impedance: 500 Ω ±5%.

dB Output — Dc output of logarithmic dB converter. 10 mV ±5% per 1 dB of display. Source impedance: 1 kΩ ±5%.

ORDERING INFORMATION

| | |
|---|------------------|
| AA 501 Distortion Analyzer | \$1950 |
| Option 01 Intermodulation Distortion | Add \$650 |

SG 505

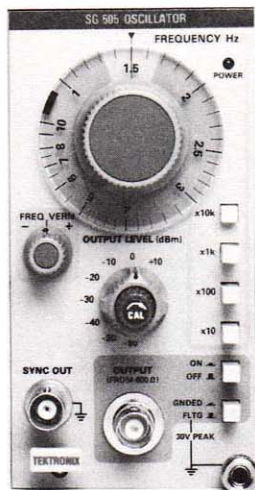

Oscillator

SG 505

10 Hz to 100 kHz Sinewave (typically 9 Hz to 110 kHz)

Ultra-Low Distortion—0.0008% THD (typically 0.0003%)

Floating Output—600 Ω Source

Vernier Frequency Control

Isolated and Ground Referenced Sync Output

Calibrated Output into 600 Ω—+10 dBm to −60 dBm

The SG 505 Oscillator: it features the lowest distortion level commercially available today in the 10 Hz to 110 kHz band (0.0008% between 20 Hz and 20 kHz). The SG 505 assures you of freedom from residual distortion effects, particularly critical when making audio and communication measurements. And, this extremely low distortion is coupled with many designed-in convenience features.

For instance, the main signal output may be floated to help avoid interference due to troublesome ground loops, or it may be ground referenced. The SG 505 also features an isolated and ground referenced sync output. This allows you to monitor the phase or the frequency of the output of the oscillator without disturbing the floating output of the main signal.

MAIN OUTPUT

Frequency Range — 10 Hz to 100 kHz in four overlapping bands. Accurate within 3% of dual setting (with Vernier at center). Vernier Range is at least ±1% of frequency setting.

Calibrated Output — Selectable from +10 dBm to −60 dBm into 600 Ω in eight 10 dB steps. Accurate to within 0.2 dB at +10 dBm and 1 kHz. Step accuracy is ±0.1 dB/10 dB step. An uncalibrated control provides continuous variation from at least +2.2 dB to < −10 dB from calibrated position.

Amplitude Response — Level flatness ±0.1 dB from 10 Hz to 20 kHz (1 kHz ref); within 0.2 dB from 20 kHz to 100 kHz excluding −60 dB output level range).

Harmonic Distortion — <0.0008% (−102 dB) THD from 20 Hz to 20 kHz (typically 0.0003%); 0.0018% (−95 dB) THD from 10 Hz to 20 Hz, and from 20 kHz to 50 kHz; 0.0032% (−90 dB) THD from 50 kHz to 100 kHz (RL ≥600 Ω).

Output Impedance — 600 Ω ±2%; floating or grounded through ≈30 Ω. Output impedance does not change with OUTPUT ON/OFF selection. Maximum floating voltage ±30 V peak.

Max Output Voltage — At least 6 V RMS open circuit; 3.16 V RMS (+10 dBV or +12.2 dBm) into 600 Ω.

SYNC OUTPUT

Signal — 200 mV RMS ±20% sinewave to 20 kHz, at least 120 mV RMS at 100 kHz.

Frequency — Same as main output.

Impedance — 1 kΩ ±10%, ground referenced and isolated from main output.

REAR INTERFACE SIGNALS

Buffered Main Output — Buffered version of actual output signal from front panel connector. ≈300 Ω Output impedance.

Sync Output — Same as front panel SYNC OUTPUT except output impedance is ≈50 Ω.

OPTION 01 IM TEST SIGNAL

Selecting the IM Test Signal causes a LF sinewave to be mixed with the normal oscillator signal in a 4.1 amplitude ratio.

Lf Frequency — Internally selectable 60 Hz (±1 Hz) or 250 Hz (±3 Hz).

Main Output — Composite p-p output within 0.2 dB of normal oscillator mode output.

Residual IMD — Typically <0.0005% from 2.5 kHz to 10 kHz.

Sync Output — Lf signal component only, 200 mV RMS ±20%.

ORDERING INFORMATION

| | |
|---|------------------|
| SG 505 Oscillator | \$690 |
| Option 01 (IM Test Signal) | Add \$150 |

SC 504

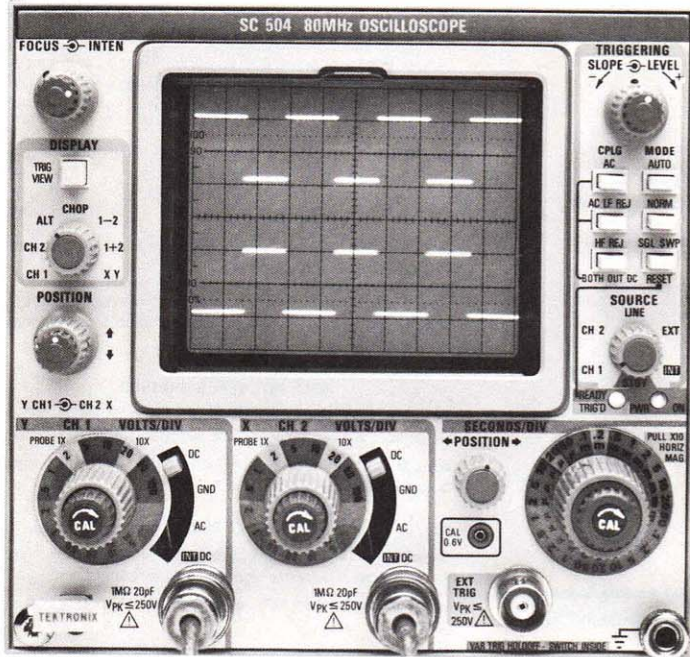

80 MHz Oscilloscope

SC 504

80 MHz Oscilloscope

5 mV/div Max Sensitivity

5 ns/div Max Calibrated Sweep Rate

Enhanced Automatic Triggering

True X-Y Capability

Switchable Rear Interface Capability

The addition of this plug-in scope makes many new configurations possible, especially for those applications demanding higher bandwidth capabilities. A double-wide plug-in, the SC 504 is compatible with all existing TM 500 Plug-ins and multi-compartment mainframes.

The SC 504 is a general purpose, dual-trace, non-delayed-sweep oscilloscope. It has a high writing speed with a maximum sensitivity of 5 mV/div, and a maximum sweep rate of 5 ns/div (with magnifier). This oscilloscope features Add (Ch 1 + Ch 2), differential (Ch 1 - Ch 2), and "true" X-Y modes, and also includes rear interfacing capability (switchable Ch 1, Ch 2 and ext trig inputs). Enhanced auto triggering, trigger view, and variable trigger holdoff make this oscilloscope very versatile and easy to use. The P6108 and P6062B are the Tektronix Probes recommended for use with the SC 504.

VERTICAL DEFLECTION

Bandwidth at -3 dB points — Dc to at least 80 MHz from 0°C to 35°C; dc to at least 70 MHz from 35°C to 50°C.

Rise Time — 4.4 ns or less from 0°C to 35°C; 5 ns or less from 35°C to 50°C.

Ac Low Frequency Response (lower -3 dB points) — Without probe, 10 Hz; with 10X probe, 1 Hz.

Deflection Factors — Calibrated Range: 5 mV to 10 V/div, 11 steps in a 1-2-5 sequence.

Accuracy — ±2%, +15°C to +35°C; ±3%, 0°C to 50°C. Uncalibrated Range — Continuously variable between calibrated steps. At least 2.5:1 range. Extends maximum deflection factors to at least 25 V/div.

Modes — Ch 1, Ch 2, Alt., Chop, Ch 1 minus Ch 2, Ch 1 plus Ch 2, X-Y. Chop rate at least 250 kHz.

Input R and C — 1 MΩ ±1% paralleled by ≈20 pF.

Max Input Voltage — 250 V (dc + peak ac), 500 V p-p ac at 1 kHz or less.

Common-Mode Rejection Ratios — At least 50:1 up to 1 MHz, and 10:1 from 1 MHz to 10 MHz when using the same attenuator settings; common-mode signal 5 divisions or less.

Position Range — ±6 div.

Delay Line — Permits viewing leading edge of displayed waveform.

Calibrator — 0.6 V, ±1%, ≈1 kHz frequency.

HORIZONTAL DEFLECTION

Sweep Generator — Calibrated Sweep Rates: 0.2 s to 50 ns/div, 21 steps in a 1-2-5 sequence, plus a X10 magnifier for sweep rates to 5 ns/div. Uncalibrated (variable) Range — The CAL (variable) control provides sweep rates that are continuously variable between the calibrated rates, and extends the slowest sweep rate to at least 0.5 s/div.

Sweep Rate Accuracy — Measured over center 8 divisions, excluding first 50 ns and all after the first 10 divisions of magnified sweep. Derate accuracies by an additional 1% from 0°C to 15°C, and 35°C to 50°C.

| | 15°C to 35°C | |
|-------------------------|--------------|-----|
| | X1 | X10 |
| 20 ms/div to 0.2 μs/div | ±2% | ±3% |
| 0.2 s/div to 50 ns/div | ±3% | ±4% |
| 0.1 μs/div to 50 ns/div | ±3% | ±4% |

Trigger Holdoff — CAL (variable) control, if selected by an internal switch, increases trigger holdoff time by a factor of at least 20.

X-Y Mode — Bandwidth: Dc to at least 2 MHz. Deflection Factor, selected by channel 2 controls and horizontal mag X1, X10 with 5% accuracy. X and Y amplifier phase difference, less than 3° at 50 kHz or less. Input parameters same as Channel 2.

TRIGGER

Trigger Modes — AUTO, NORM, and SGL SWP.

Enhanced Auto Trigger — The trigger circuit automatically adjusts to spread the peak-to-peak signal over most of the range of the triggering level control. This provides more convenient triggering, especially on low amplitude signals.

Trigger Sources — Ch 1, Ch 2, LINE, EXT, INT.

Trigger Coupling — Ac, ac Lf REJ, ac Hf REJ, dc.

Trigger Sensitivity — Minimum Peak to Peak Signal Required.

| Coupling | Source | DC to 30 MHz | 30 MHz to 80 MHz |
|-----------|-------------------------------|---|---|
| Dc | Ch 1, Ch 2 External Interface | 0.4 div 60 mV Typ 50 mV | 1.0 div 150 mV Typ 100 mV to 50 MHz |
| Ac | | Requirements increase below approx 50 kHz | |
| Ac Lf REJ | | Requirements increase below approx 10 kHz | |
| Hf REJ | | Requirements increase above approx 50 kHz | |

External Triggering Level Range — ≥ ±1.4 V.

External Triggering Input — Input R and C — 1 MΩ ±10% paralleled by approximately 24 pF. Maximum Input Voltage — 250 V (dc + peak ac); 250 V p-p at 1 kHz or less.

AUTO Mode — Sweep free runs in the absence of a triggering signal. TRIGGER LEVEL range is reduced to approximately the p-p range of the triggering signal.

Single Sweep — Triggering requirements are as for normal sweep. When triggered, sweep generator produces one sweep only.

CRT

Phosphor — P31.

Acceleration Potential — ≈12 kV.

Graticule — Scale, 8 x 10 div with 0.25 in/div internal graticule lines.

REAR INTERFACE

Ch 1 and Ch 2 Vertical Inputs — Selected by Ch 1 and Ch 2 coupling in INT (interface) position. Input impedance: 50 Ω. Can be customer-modified for input impedance of 1 MΩ paralleled by ≈60 pF.

Trigger Input — Selected by TRIGGER SOURCE switch in INT (interface) position. Input impedance: 50 Ω when selected, 25 Ω when not selected. Can be customer-modified for input impedance of 1 MΩ paralleled by ≈40 pF.

Z-Axis Input — Input Impedance: ≈1.5 kΩ. +5 V turns beam ON from OFF condition, -5 V turns beam OFF from ON condition.

Channel 1 Output — At least 50 mV/div. Bandwidth: At least 30 MHz. Output Impedance: <50 Ω.

Ramp Output — 0 to +10 V ramp. Output resistance ≈500 Ω.

ENVIRONMENTAL CAPABILITIES

Temperature — Operating: 0°C to 45°C (to 50°C in mainframes equipped with fan). Nonoperating: -55°C to +75°C.

Altitude — Operating: To 15,000 feet. Nonoperating: To 50,000 feet.

Order SC 504 80 MHz Oscilloscope .. \$2910

SC 503

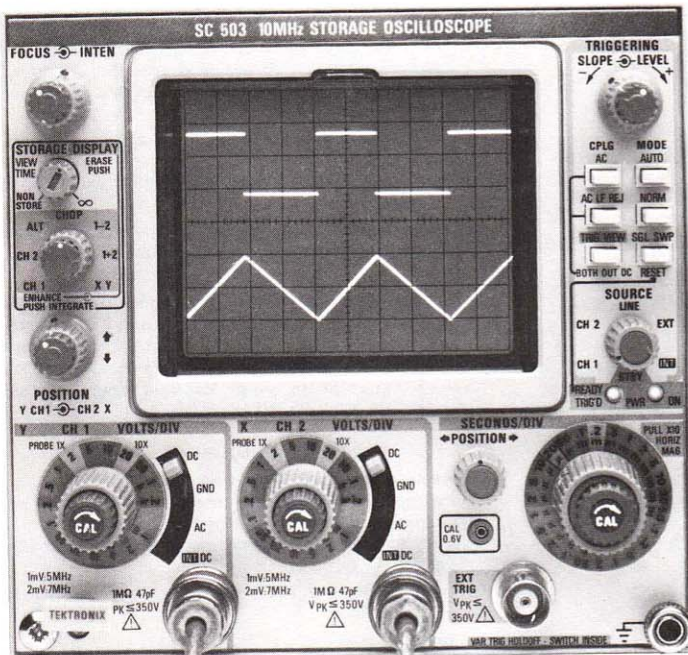

10 MHz Storage Oscilloscope

SC 503

10 MHz Bandwidth

Bistable Storage Auto-erase

Variable Enhancement and Integration to Increase Writing Speed

Trigger View

Variable Holdoff

Switchable Front/Rear X and Y Inputs

Rear Z Axis Input

True X-Y Capability

The SC 503 is a non-delayed sweep, general purpose storage oscilloscope which is compatible with five of our TM 500 Mainframes, (TM 503, TM 504, TM 515, TM 506 and RTM 506).

Because the SC 503 is a storage oscilloscope, it can be used to store and display waveforms after the input signal is removed. This feature is particularly useful when measuring slow repetition rates or single-shot signals, important in the biomedical and mechanical measurements fields. Low frequency signals at heart or respiration rates can be stored for detailed analysis. In the mechanical measurements field the SC 503 can "freeze" fast or transient signals from transducers, which is especially useful in pressure and velocity vs. time analysis and shock testing.

Other important storage applications of the SC 503 include measurements of signals in computer peripherals, communication terminals and industrial control systems.

Major features of the SC 503 include; variable enhancement and integration to increase the writing speed of signals with rapid rise times, an auto erase mode which erases the stored signal and automatically retriggers the oscilloscope, and X-Y capability. The X-Y capability allows creation of Lissajous patterns in many cause and effect testing relationships including : acoustic speech testing, nerve potential testing, and optical stimulus response testing. The P6108, P6062B and P6060 are the Tektronix recommended probes for use with the SC 503.

VERTICAL DEFLECTION

Bandwidth at -3 dB points — Dc to at least 10 MHz, (5 mV/div to 20 mV/div); dc to at least 7 MHz (2 mV/div), dc to at least 5 MHz (1 mV/div).

Rise Time — 5 mV to 20 V/div, typically 35 ns or less.

Ac Low-Frequency Response (lower -3 dB points) — Without probe, 10 Hz; with 10X probe 1 Hz.

Deflection Factors — Calibrated Range: 1 mV/div to 20 V/div, 14 steps in a 1-2-5 sequence. Accuracy — 5 mV to 20 V/div (+15°C to +35°C) ±3%, 1 mV/div and 2 mV/div ±5%; (derate accuracy by additional 1% for 0°C to +50°C). Uncalibrated Range: at least 2.5:1 continuously variable between calibrated steps: Extends maximum uncalibrated deflection factor to at least 50 V/div.

Modes — Ch 1, Ch 2, ALT, CHOP, Ch 1 minus Ch 2, Ch 1 plus Ch 2, X-Y. Chop rate at least 250 kHz.

Input Impedance — 1 MΩ ±1% paralleled by ≈47 pF.

Maximum Input Voltage — 350 V (dc + peak ac), 700 V p-p ac at 1 kHz or less. Above 1 kHz recommended p-p ac limit is 250 V to 10 kHz derating to 25 V above 100 kHz.

Common-Mode Rejection Ratio — At least 50:1 at 1 MHz when using same attenuator setting, in Ch 1 minus Ch 2 mode.

Delay Line — Permits viewing leading edge of displayed waveform.

Calibrator — 0.6 V, ±1%, ≈1 kHz frequency.

Position Range — ±6 div.

Channel Isolation — 2% or less display related crosstalk to 10 MHz.

Displayed Noise — <0.2 mV peak to peak at 1 mV/div.

HORIZONTAL DEFLECTION

Sweep Generator — Calibrated sweep rates: 2 s/div to 0.5 μs/div, 21 steps in a 1-2-5 sequence, plus a X10 magnifier for sweep rates to 50 ns/div. Uncalibrated (variable) Range provides continuously variable sweep rates, between the calibrated rates, and extends the slowest rate of at least 5 s/div.

| Sweep Rate Accuracy — | +15°C to +35°C | |
|------------------------|----------------|-----|
| | X1 | X10 |
| 2 s/div to 0.5 s/div | ±4% | ±5% |
| 0.2 s/div to 5 μs/div | ±3% | ±4% |
| 2 μs/div to 0.5 μs/div | ±4% | ±5% |

Derate accuracy by an additional 1% from 0°C to 15°C and 35°C to 50°C.

Trigger Holdoff — At least 20:1 range internally selectable.

X-Y Mode — Bandwidth: dc to at least 500 kHz. Deflection Factor: selected by Ch 2 controls and Horizontal Mag X1, X10. Phase Difference: <3° at 50 kHz or less.

TRIGGER

Trigger Modes — AUTO (enhanced), NORM, and SGL SWP (single sweep).

Enhanced Auto Trigger — The trigger circuit automatically adjusts to spread the p-p signal over most of the range of the triggering level control. This provides more convenient triggering, especially on low amplitude signals.

Trigger Sources — Ch 1, Ch 2, LINE, EXT, INT (rear interface).

Trigger Coupling — Dc, ac, ac Lf REJ.

Trigger Sensitivity — Minimum p-p signal required.

| Source | dc to 5 MHz | 5 MHz to 10 MHz |
|------------|-------------|-----------------|
| Ch 1, Ch 2 | 0.4 div | 1.0 div |
| External | 60 mV | 150 mV |
| Interface | Typ 35 mV | Typ 80 mV |

*With ac coupling requirements increase below ≈50 Hz. With ac Lf REJ coupling requirements increase below ≈10 kHz.

Triggering Level Range — External: at least ±1.2 V. Internal: at least -6.0 divisions.

External Triggering Input — Input Impedance: 1 MΩ, paralleled by ≈47 pF. Maximum Input Voltage: 350 V (dc + peak ac), 350 V p-p at 1 kHz or less. Above 1 kHz recommended p-p ac limit is 100 V to 10 kHz derating to 10 V above 100 kHz.

Auto Mode — Sweep free-runs in the absence of a triggering signal. Level control range automatically varies with the triggering signal amplitude for frequencies above 100 Hz.

Single Sweep — Triggering requirements same as for normal sweep. When triggered, sweep generator produces one sweep only.

STORAGE SYSTEM

Stored Writing Speed (center 6 x 8 divisions) — Normal: at least 80 div/ms (50 cm/ms). Enhanced: at least 400 div/ms (250 cm/ms).

Erase Time — 400 ms to 600 ms.

Auto Erase Viewing Time — Continuously variable from ≤0.5 s to ≥5 s.

Maximum Recommended Storage Time — ≈4 hours.

CRT

Phosphor — P44.

CRT Graticule — 8 x 10 div., 0.25 inch/div (0.64 cm/div). Internal graticule lines.

REAR INTERFACE

Ch 1 and Ch 2 Vertical Inputs — Selected by Ch 1 and Ch 2 coupling in INT (interface) position. Input Impedance: 50 Ω. Can be customer-modified for input impedance of 1 MΩ paralleled by ≈100 pF.

Trigger Input — Selected by TRIGGER SOURCE switch in INT (interface) position. Input Impedance: 50 Ω, when selected, 25 Ω when not selected. Can be customer-modified for input impedance of 1 MΩ paralleled by ≈60 pF.

Z-Axis Input — Input Impedance: ≈1.5 kΩ. +5 V turns beam ON from OFF condition, -5 V turns beam OFF from ON condition.

Ch 1 Output — At least 50 mV/div. Bandwidth: at least 4 MHz. Output Impedance: 50 Ω.

Ramp Output — 0 to +10 V ramp. Output impedance ≈500 Ω.

ENVIRONMENTAL CAPABILITIES

Temperature — Operating: 0°C to +45°C (0°C to +50°C in mainframe equipped with a fan). Nonoperating: -55°C to +75°C.

Altitude — Operating: to 15,000 feet; maximum operating temperature decreased by 1°C/1000 feet from 5000 feet to 15,000 feet. Nonoperating: to 50,000 feet.

Order SC 503 10 MHz Storage Oscilloscope \$3150

SC 502

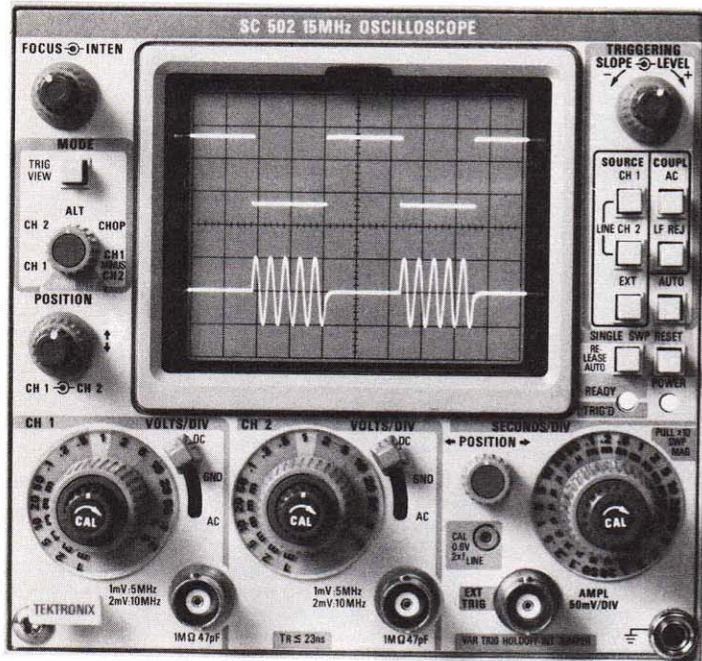

15 MHz Dual-Trace Oscilloscope

SC 502

15 MHz Bandwidth

Dual-Trace

20 ns/div Max Calibrated Sweep Rate

1 mV/div Max Sensitivity

Delay Line

Trigger View

Variable Trigger Hold-off

Enhanced Automatic Triggering

The SC 502 is a compact general-purpose 15 MHz dual-trace oscilloscope designed to operate in any two adjacent compartments of TM 500 Power Module/Mainframes. It has a high writing speed, a wide range of sweep rates, a wide range of deflection factors, and versatile triggering, including trigger view and enhanced automatic triggering.

As with many Tektronix Products, the SC 502 features circuits, sub-circuits, and components designed and built by Tektronix to fulfill the special design capabilities of the instrument. Among its many recommended uses, the SC 502 is intended to be a powerful tool in the field servicing of digital equipment, where it would be used in association with disc memories, key-tape, printers, plotters, punches, readers, and terminals. The CRT of the SC 502 offers a high writing speed as an advantage in the display of digital information, while stable, clean triggering is assured by incorporating well proven circuits. Thus, the SC 502 offers the engineer a unique combination of performance, compactness, and systems capability.

The SC 502 makes many new instrumentation systems feasible, especially in the areas of QA, production testing, maintenance, and field servicing. The rear interfacing capability of the SC 502 and all TM 500 Instrumentation suggests exceptional applicability to systems of built-in test equipment or rackmounted installations. And the TM 515 Traveler Mainframe with the SC 502 form a nucleus for sophisticated, compact field service "packages."

Tektronix Probes P6062B and P6108 are recommended for use with the SC 502.

VERTICAL DEFLECTION

Bandwidth at -3 dB points — 5 mV to 20 V/div, dc to at least 15 MHz; 2 mV/div, dc to at least 10 MHz; 1 mV/div, dc to at least 5 MHz.

Rise Time — 5 mV to 20 V/div, 23 ns or less.

Ac Low-Frequency Response (Lower -3 dB points) — Without probe, 10 Hz; with probe (10X), 1 Hz.

Deflection Factors — Calibrated range: 1 mV to 20 V/div, 14 steps in a 1-2-5 sequence. Accuracy: 5 mV to 20 V/div (+15°C to +35°C) within 2%, (0° to +50°C) within 3%; 1 mV and 2 mV/div within 5%. Uncalibrated (variable) range. At least 2.5:1 range. Continuously variable between calibrated steps. Extends max attenuator step to at least 50 V/div.

Modes — Ch 1, Ch 2, ALT, CHOP, Ch 1 MINUS Ch 2. Chop rate at least 250 kHz. Triggering waveform is displayed instead of selected display when desired.

Input Impedance — 1 MΩ within 1% paralleled by ≈ 47 pF.

Max Input Voltage — 350 V (dc + peak ac), 700 V p-p ac at 1 kHz or less.

Common-Mode Rejection Ratio (Ch 1 minus Ch 2 mode) — At least 30:1 at 1 MHz when using same attenuator setting.

Channel Isolation — 2% or less display related crosstalk to 15 MHz.

Displayed Noise — ≤ 0.2 mV p-p at 1 mV/div.

Position Range — ± 6 div.

Calibrator — Voltage, 0.6 V ± 1%. Frequency, twice the power line frequency.

HORIZONTAL DEFLECTION

Sweep Generator — Calibrated Sweep Rates: 0.5 s to 0.2 μs/div, 20 steps in a 1-2-5 sequence, plus a X10 magnifier for sweep rates to 20 ns/div. Uncalibrated (variable) Range: the CAL (variable) control provides sweep rates that are continuously variable between the calibrated rates, and extends the slowest sweep rate to at least 1.25 s/div.

Sweep Rate Accuracy — Within 3% unmagnified, 4% magnified, +15°C to +35°C. Derated by an additional 1% for 0°C to +15°C and +35°C to +50°C.

Trigger Holdoff — CAL (variable) control, if selected by an internal jumper, increases trigger holdoff time by a factor of at least 20.

External Horizontal Amplifier — Bandwidth: dc coupled, dc to at least 2 MHz; ac coupled <50 Hz to at least 2 MHz. Deflection Factor, 50 mV/div within 5%. X and Y Amplifier Phase Difference, <3° at 50 kHz or less. Input Impedance, 1 MΩ within 2% paralleled by ≈ 47 pF. Max Input Voltage: 350 V (dc + peak ac); 350 V p-p at 1 kHz or less.

TRIGGER

Enhanced Automatic Triggering — In the automatic mode, the trigger circuit automatically adjusts to spread the p-p signal over most of the range of the triggering level control. This provides more convenient triggering, especially on low amplitude signals.

Trigger Modes — AUTO (enhanced), NORMAL (auto button out), SINGL SWP.

Trigger Sources — Ch 1, Ch 2, LINE EXT.

Trigger Coupling — Dc, ac, ac Lf REJ.

Trigger Sensitivity — Minimum p-p signal required.

| Source | dc to 5 MHz | 5 MHz to 15 MHz |
|----------|-------------|-----------------|
| Ch, Ch 2 | 0.4 div | 1.0 div |
| External | 60 mV | 150 mV |

With ac coupling requirements increase below ≈ 50 Hz. Ac Lf REJ coupling requirements increase below ≈ 5 kHz.

Triggering Level Range — Internal: at least ± 8 div. External: at least ± 1.2 V.

External Triggering Input — Input Impedance: 1 MΩ within 2% paralleled by ≈ 47 pF. Max Input Voltage: 350 V (dc + peak ac); 350 V p-p ac at 1 kHz or less.

Auto Mode — Sweep free-runs in the absence of a triggering signal. TRIGGER LEVEL range is reduced to approx the p-p range of the triggering signal.

Single Sweep — Triggering requirements same as for normal sweep. When triggered, sweep generator produces one sweep only. AUTO pushbutton must be in the OUT position for operation and for setting triggering controls.

CRT

Phosphor — P31.

Deflection — Electrostatic.

Acceleration Potential — ≈ 12 kV.

Graticule — Scale, 8 x 10 div with 0.25 in/div internal graticule lines.

ENVIRONMENTAL CAPABILITIES

Temperature — Operating, 0°C to +45°C (to +50°C in mainframes equipped with fan). Nonoperating — 55°C to +75°C.

Altitude — Operating, to 15,000 ft. Nonoperating to 50,000 ft.

Order SC 502 15 MHz Oscilloscope . \$2140

SC 501

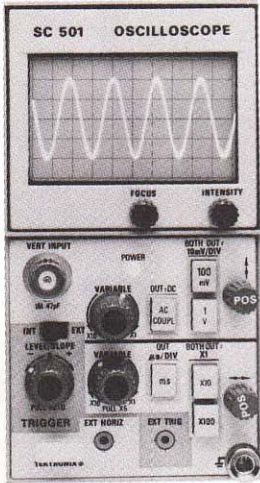

Oscilloscope

SC 501

5 MHz Bandwidth

Single Compartment Size

6.4 cm (2.5 inches) CRT

Versatile Operating Features

The SC 501 is a single-channel 5 MHz plug-in unit oscilloscope with a 2.5 inch CRT display which occupies a single TM 500 Series Plug-in compartment. Oscilloscope capability significantly enhances the application range of the multifunctional TM 500 Series Test and Measurement Instruments.

With the SC 501 a multitude of versatile test systems may be structured from the TM 500 Series to suit specific needs for time and frequency response, modulating waveforms, power for devices under test, stimulus and response studies and voltage, current, and temperature measurements. Since the SC 501 fits any TM 500 Mainframe, it can be used on the bench, in a rack, or on the road. The single-channel SC 501 has a calibrated vertical deflection range from 10 mV/div to 1 V/div, selectable in decade steps. A variable control extends this range to at least 10 V/div.

Calibrated sweep rates are selected by pushbutton logic in decade steps from 1 μ s/div to 100 μ s/div (microsecond), and from 1 ms/div to 100 ms/div (millisecond range). A variable control extends the slowest sweep rate to at least 1 s/div and a fixed magnifier extends the fastest sweep rate to 200 ns/div.

A 0 to 10 V ramp for all sweep rates (excluding the X5 magnification) is provided at a rear interface connector. This capability may be used for many auxiliary functions such as sweeping a voltage-controlled frequency oscillator or obtaining variably delayed pulses from the PG 505 Pulse Generator.

The triggering circuits allow stable triggering from either internal or external sources. An AUTO triggering mode and manual LEVEL/SLOPE selection is combined in a single control. It is useful above 10 Hz and provides a bright baseline at all sweep rates.

An internal switch converts the horizontal deflection system of the SC 501 to an external horizontal amplifier which is internally calibrated for 100 mV/div deflection factor with a bandwidth of 100 kHz.

VERTICAL DEFLECTION

Bandwidth — Dc to >5 MHz.
Deflection Factors — 10 mV/div, 100 mV/div, and 1 V/div. Accuracy, within 3%. Uncalibrated (variable) range, continuously variable between steps (10:1) and to at least 10 V/div.
Input Coupling — Ac or dc.
Input Impedance — 1 M Ω paralleled by 47 pF.
Max Input Voltage — 350 V (dc + peak ac).

HORIZONTAL DEFLECTION

Time Base — Calibrated sweep rates: 1 μ s/div to 100 ms/div in decade steps. Uncalibrated (variable) range: extends slowest calibrated rate to \geq 1 s/div. X5 magnifier (fixed): extends fastest calibrated sweep rate to 200 ns/div. Accuracy (over center 8 div): \geq 5% for all sweep rates. Linearity (any two div portion within center eight div): \geq 5%.
External Horizontal Amplifier — Bandwidth: dc to 100 kHz. Input Impedance: \geq 100 k Ω paralleled by 25 pF. Max input voltage: \pm 3 V.

TRIGGER

Normal Trigger Sensitivity (Trigger Level/Slope In) — Internal: dc coupled, 0.4 major div of deflection at dc; Increasing to 1.0 major div of deflection at 5 MHz. External: dc coupled, 1 V minimum to 5 V max from dc to 5 MHz. External trigger input impedance: 22 k Ω paralleled by \approx 150 pF.
Auto (Trigger Level/Slope Out) — Sweep free-runs in absence of trigger signal, or for trigger repetition rates below 10 Hz.

CRT

Phosphor — P31.
Graticule — 6 X 10 div (0.203 in per div).

Order SC 501 5 MHz Oscilloscope ... \$1040

OSCILLOSCOPES COMPARISON CHART

| | SC 504 | SC 503 | SC 502 | SC 501 |
|---------------------|---|--|---|--|
| CRT | 8 x 10 div, 0.25 in/div P31 Phosphor | 8 x 10 div, 0.25 in/div, Bistable Storage, P44 Phosphor | 8 x 10 div, 0.25 in/div P31 Phosphor | 6 x 10 div, 0.203 in/div P31 Phosphor |
| Vertical (Y) axis | Dual-trace, 80 MHz, 5 mV/div to 10 V/div, Alt, CHOP, Ch 1 minus Ch 2, Ch 1 + Ch 2, X-Y modes | Dual-trace, 10 MHz, 1 mV/div to 20 V/div, Alt, CHOP, Ch 1 minus Ch 2, Ch 1 + Ch 2, X-Y modes | Dual-trace, 15 MHz, 1 mV/ per div to 20 V/div (5 and 10 MHz bandwidth at 1 and 2 mV) ALT, CHOP, and Ch 1 minus Ch 2 modes | 5 MHz bandwidth, 10 mV/ div to 10 V/div |
| Horizontal (X) axis | Triggered sweep 50 ns/div to 0.2 s/div with X10 magnifier. Enhanced auto trig, line ext/int trig, single sweep, external horizontal input, variable trigger holdoff | Triggered sweep 50 ns/div to 2 sec/div with X10 magnifier. Enhanced auto trig, line, ext/int trig, single sweep, external horizontal input, variable trigger holdoff | Triggered sweep 200 ns/div to 0.5 s/div with X10 magnifier, enhanced auto, trigger, line, ext/int trig, single sweep, external horizontal input, variable trigger holdoff | Triggered sweep 1 μ s/div to 1 s/div with X5 mag- nifier to 200 ns/div, normal/auto trigger, in- ternal/external-trigger, external horizontal input |
| Other features | Trigger view, switchable rear interface capability | Bistable storage, auto erase, variable enhance- ment and integration, rear interface capability, trigger view | Trigger view | Compact display |
| Price | \$2910 | \$3150 | \$2140 | \$1040 |

INTERFACE PRODUCTS

The term "Interface Product" is used here as a generic term and is meant to describe a combination of TM 5000 products designed to provide a solution to the problem of interfacing test and measurement instruments to a device under test, a control process, or to the external environment. These products supply digital input and digital output data to control instruments, indicators, or relays and can accept digital data from switches, pushbuttons, and other digital data sources. Multiple processes can be controlled in parallel by programming the interface products to conduct a sequence of events which can be executed while a system controller directs activity elsewhere.

NEW

MI 5010

**GPIB
IEEE-488**

The MI 5010 is designed to comply with IEEE Standard 488-1978, and with Tektronix Codes and Formats Standard.

Customer Configured

Automatic Self Test

Triggered Externally or on Command

Built in Real Time Clock

Mnemonic Instructions

Instruction Buffer for Unattended Operation

The MI 5010 Programmable Multifunction Interface is a two-wide, TM 5000 Series plug-in capable of accepting a total of three function cards.

The MI 5010, with appropriate function cards installed, is a GPIB compatible system capable of:

--Producing, on command from a GPIB controller, either analog or digital output signals to control the events or conditions in an external system.

--Receiving, on request from a GPIB controller, input signals (analog or digital) from external sensor points that represent events or conditions in an external system.

The MI 5010 has its own intelligence and a built in buffer capable of storing from 80 to 300 commands (depending on command length). The buffered commands are sequenced in order and can be paced with a built-in real time clock, built-in wait timer, external trigger or software trigger from the system controller.

One, two, or three function cards plug into the front of the MI 5010 and communicate with a microprocessor control card in the MI 5010 via the backplane connectors of the MI 5010.

Each function card in the MI 5010 or MX 5010 contains its own ROM with the specific firmware required for that function. Each function can be programmed with its own, unique set of software commands.

Order MI 5010 Multifunction Interface \$1350

MX 5010 — Multifunction Interface Extender

The Multifunction Interface Extender is a two-wide, TM 5000 plug-in which, when used, mechanically attaches to the MI 5010 and provides the capability of accepting three extra function cards into the system. The multifunction interface extender is electrically identical to the MI 5010

MI 5010

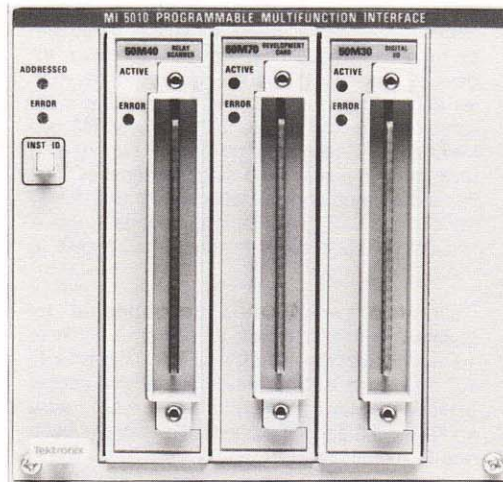

Programmable Multifunction Interface

with the microprocessor control card removed. The combination of the MI 5010 and the MX 5010 allows a total of six function cards to be controlled by the microprocessor control card in the MI 5010 via commands from the GPIB.

Digital control signals between the MX 5010 and the MI 5010 are connected via a flat ribbon cable at the backplane connector.

Order MX 5010 Interface Extender \$650

50M30 — Programmable Digital Input/Output Card

16 Digital Input and 16 Digital Output Lines

Triggered Externally or on Command

Mnemonic Instructions

Self Test and Error Indicator

The Programmable Digital Input/Output Card is a function card used in either the MI 5010 or the MX 5010. The 50M30 contains its own ROM with the firmware specified for the card, and is programmed with its own set of software commands.

The 50M30 provides 16 digital input and 16 digital output lines. The digital inputs accept data from pushbuttons, switches, contact closures, and most digital devices capable of supplying TTL output levels. The digital outputs provide TTL levels to control various types of test and measurement instruments, relays, indicators, etc. The digital outputs can be configured for open-collector outputs by positioning internal jumpers and using power supplied by the user.

Programming of the 50M30 is via the IEEE-488 (GPIB) bus specified and described in IEEE-488 Standard 488-1978. System commands sent to the MI 5010 Microprocessor, along with specialized programming commands unique to the 50M30, control the selection of the data input/output channels and the arming/trigger functions of the card.

Four lines at the front panel connector operate as input/output pairs to handshake data with the user's external system. One handshake pair allows the user's data source to be synchronized with the 50M30 data input register and the other handshake pair allows the user's data storage device to be synchronized with the 50M30 data output register.

50M30 CHARACTERISTICS

Data Outputs Using Internal Supply — 16 open-collector TTL with 2 k Ω pullup resistors. Logical "1": +5 V \pm 2% (open circuit). Source current -2.5 mA \pm 7% maximum. Logical "0": ≤ 0.2 V. Sink current -40 mA maximum.

Data Outputs Using External (User) Supply — Maximum Voltage: +15 V. Pull-up Resistors: 2 k Ω . Logical "1" Equal to external supply voltage (open circuit). Source current = 7.5 mA \pm 5% plus external supply tolerance. Logical "0": ≤ 0.2 V. Sink current 40 mA maximum.

Data Inputs — Input Buffers; 16 Schmitt triggers. Logical "1" (+V threshold); +1.6 V \pm 25%. Source current = -0.14 mA nominal, -0.16 mA maximum. Logical "0" ($-V$ threshold); +0.8 V \pm 40%. Source current = -0.18 mA nominal, -0.21 mA maximum.

Order 50M30 Digital Input/Output Card . \$400

50M40 — Programmable Relay Scanner Card

16 Mercury Wetted Relay Contacts

Triggered Externally or on Command

Mnemonic Instructions

Self Test and Error Indicators

The Programmable Relay Scanner Card is a function card used in either the MI 5010 or MX 5010. The 50M40 contains its own ROM with the firmware specified for the card, and is programmed with its own set of software commands.

The 50M40 provides 16 independent, normally-open relay contacts. The relay contacts may be used as switch closures to supply power to several external points from one source, or scan several sources and supply various inputs to a single measurement device.

The desired relay switch pattern is configured by the user with internal jumpers. When the configuration has been established, the relay scanning sequence, open and close operations, and triggering events are programmed over the IEEE-488 (GPIB) bus described in IEEE Standard 488-1978.

The relay channel configurations are not program-controlled and the 16 relay contacts must be jumpered in various combinations of switch closure patterns. Three possible combinations are:

- 4 groups of 4 individual relays
- 2 groups of 8 individual relays
- 1 group of 16 individual relays

Scanning sequence and relay closure is accomplished under program control. Two logic signal lines on the front panel connector are provided for externally controlling the 50M40—one as an output (READY) to indicate to the user when the relays have settled, and the other as an input (EXT TRIG) to tell the MI 5010 Microprocessor that the user is ready for the relay switch configuration to close.

50M40 CHARACTERISTICS

Type of Relays — Mercury wetted reed.

Possible Configurations (Jumper Selectable) — 1 of 4, 4 each, 1 of 8, 2 each, 1 of 16, 1 each, 1 of 12 and 1 of 4, 1 each. Pull In Time: 3 ms, nominal. 30 V connected to common port through 30 k Ω . Release Time: 3 ms, nominal. Sequence through all relays. Contact Resistance: 0.5 Ω nominal (end of life). Peak Applied Voltage: 40 V, maximum. Peak Contact Current: 1A, maximum. Breakdown Voltage: 100 V dc plus peak ac. Frequency Range: Dc to 1 MHz.

Order 50M40 Relay Scanner Card \$575

50M70 — Programmable Development Card

Develop IEEE-488 Specialized Functions Easily

Mnemonic Instructions

Self Test and Error Indicator

The Programmable Development Card is a function card used in either the MI 5010 or the MX 5010. The 50M70 contains its own ROM with the firmware necessary for IEEE-488 operation of a user's specialized circuit.

The 50M70 contains two interface logic registers, address and data buffers, a breadboard area for user development, and (as previously mentioned) its own firmware.

Possible applications are:

- Specialized DAC/ADC functions
- Timing functions
- Special communication interface functions
- Keyboard/Display functions, etc.

Special features of the 50M70 include:

- Programmable data direction registers (input/output)
- Programmable trigger conditions
- Programmable data transfer, register configuration, status, and interrupts
- Front panel edge connector configured by the user

50M70 CHARACTERISTICS

I/O through I/O 7 — Open-circuit voltage on Pins 1 through 8 on J1200, J1202, J1210, and J1214. Output High Level; +2.4 V minimum, +5.5 V maximum. Output Low Level; 0 V minimum, +0.4 V maximum. Load current = 1.6 mA nominal. Maximum Load (Sink) Current (Any Output); 3.2 mA at 0.4 V dc. Input Low Current; 1.3 mA nominal, 2.4 mA maximum. V_{IH} = 0.4 V dc. User Ground Points; Analog Ground; TP1201, TP1202. Digital Ground; TP1211, TP1212.

ACTIVE Indicator Voltage — Output High Level; +2.4 V minimum, +5.5 V maximum. J1216, pin 1 pulsed for 20 ms or greater.

READY Lines — Pin 10 on J1200 and J1210. Output High Level; +2.4 V minimum, +5.5 V maximum. I_{Lr} = -200 μ A. Output Low Level; 0 V minimum, 0.4 V maximum. I_L = 3.2 mA maximum.

TRIG Lines — Inputs on pin 9 of J1200, J1202, J1210, and J1214; Input leakage current = 1.0 μ A minimum, 2.5 μ A maximum. Minimum Hold Time; 3 μ s.

ACCEPT/ERROR Lines — Pin 10 J1214/Pin 10 J1202. Output High Level; +4.5 V minimum, +5.5 V maximum. I_L = 10 μ A. Output Low Level; 0 V minimum, +0.4 maximum. I_L = 3.2 mA maximum.

ERROR Line States — High during self-test, goes low if no error.

J1201, Pin 1; +26 V dc, \pm 9%. 100 mA maximum. J1201, Pin 2; -26 V dc, \pm 9%. 100 mA maximum. J1212, Pin 1; +8 V dc, \pm 5%. 600 mA maximum. J1212, Pin 2; +5 V dc, \pm 5%. 1.5 A maximum.

Total Combined Power Limit — Not to exceed 7.5 W.

Standard Accessories — Function Card Extender Cable 015-0430-00, one Reference Guide 070-3832-00.

Order 50M70 Development Card \$325

Optional Accessories —

015-0430-00 User Cable \$50

SI 5010

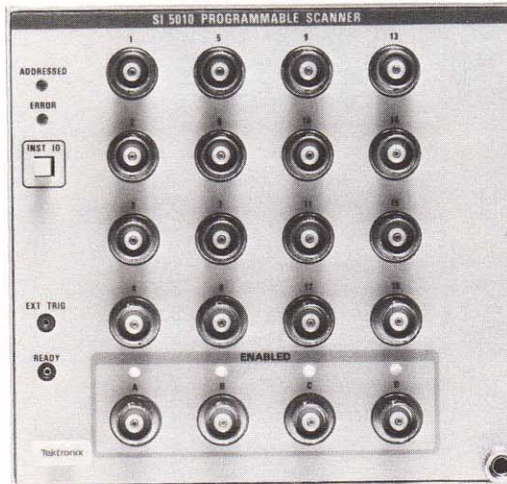

Programmable R.F. Scanner

NEW
SI 5010

GPIB
IEEE-488

The SI 5010 is designed to comply with IEEE Standard 488-1978, and with Tektronix Codes and Formats Standard.

Software Configured

Mnemonic Instructions

Triggered Externally or on Command

Built in Real Time Clock

Instruction Buffer for Unattended Operation

350 MHz Bandwidth (1 ns Rise time)

The R.F. scanner is a two-wide, TM 5000 plug-in capable of scanning and switching 16 different signal channels, or a combination of signal channels, under program control. OPTIMUM frequency response is 350 MHz.

Of the 20 front panel BNC connectors used for channel switching, 16 are connected internally to 16 R.F. reed relays and 4 are connected to common points. The common points act as output connectors to an external system. The 16 relays can be programmed to connect to the common points in various combinations. Three possible combinations are:

- 4 groups of 4 channels
- 2 groups of 8 channels
- 1 group of 16 channels

For scanning, channel grouping is always done in groups of four with each individual channel exhibiting a characteristic impedance of 50 Ω s and providing minimum R.F. signal degradation when configured for one or more groups of 4 individual channels. Channel rise time for groups of 4 channels is approximately 1 nanosecond and degrades to about 4.0 ns for 1 group of 16.

It is possible, under program control, to build a matrix using any or all 16 input channels while leaving the normal output channels disconnected. The possible number of combinations precludes characterization, and it is recommended that any such matrix established be characterized if any degradation of signal quality is a consideration.

The SI 5010 has its own intelligence and a built in buffer capable of storing from 80 to 300 commands (depending on command length). The buffered commands are sequenced in order and can be paced with a built-in real time clock, built-in wait timer, external trigger or software trigger from the system controller.

SI 5010 CHARACTERISTICS

RF Connectors — Twenty BNC connectors, sixteen channel and four common.

Control Input (Ext Trig) — External Trigger; TTL compatible
Control Output Data Accepted (READY) — TTL compatible. Output goes high when relays have settled.

Channel Configuration (Software Selectable) — 1, 2, 3, or 4 groups of 4 channels. 2 groups of 8 channels. 1 group of 16 channels.

Frequency Response — Any 1 group of 4; -3 dB at 350 MHz, decreasing to -6 dB at 500 MHz or greater. Any 1 group of 8; -3 dB at 175 MHz or greater. Any 1 group of 16; -3 dB at 80 MHz or greater.

Port (Channel) Isolation — 40 dB at 100 MHz.

Characteristic Impedance (Each Channel) — 50 Ω . See VSWR specification.

Rise Time (Each Channel) — <1 ns.

Voltage Standing Wave Ratio (VSWR) — Any 4 channel group, 1.25:1 at 100 MHz, increasing to 1.8:1 at 350 MHz. Any other combination; 1.5:1 at 100 MHz. 2:1 at 225 MHz.

Insertion Loss — <1 dB at 100 MHz.

Channel Delay Matching — Any group of 4; 50 picoseconds. Any group of 8; 110 picoseconds. Group of 16; 310 picoseconds.

Type of Relays — 16 Form A, EAC 05Y21A1 40 BAB, or equivalent. 4 Form "C", TO-5, Teledyne 712-6, or equivalent. Pull In Time; 3 milliseconds. Release Time; 3 milliseconds. Breakdown Voltage; 350 V (dc + peak ac). Series Path Resistance (End of Life); 0.5 Ω .

Peak Carry Voltage — Underterminated; 40 V maximum. 50 Ω terminated; 12.5 V maximum.

Peak Contact Current — 0.25 A maximum.

Peak Switching Voltages — Underterminated; 15 V Maximum. 50 Ω ; 3.73 V Maximum.

Peak Switching Current — .01 Amp Maximum.

Order SI 5010 R.F. Scanner \$1850



NEW

4041 System Controller

**GPIB
IEEE-488**

The 4041 is designed to comply with IEEE Standard 488-1978 and with Tektronix Codes and Formats Standard.

Optimized for Instrumentation Control

Modular Design – Rackmount or Portable

Efficient, Easy to use BASIC Language with Extensions

Expandable Capability Through Memory (to 160K Bytes) and Other Options

The new 4041 Controller is a powerful, flexible, expandable IEEE-488 systems controller designed to work with Tektronix and other vendor's IEEE-488 instruments. While the basic unit is intended principally for low user-skill environments such as production line testing, a variety of options and peripherals will equip the 4041 for full interactive flexibility in research lab applications. Tektronix full line of terminals (graphics or alphanumeric, storage or raster, and color) are fully compatible to create an optimum programmer interface in the more sophisticated areas. Software features similarly span the range from the occasional programmer to the sophisticated programming team tackling complex products. The basic 4041 compactness, coupled with compact TM 5000 IEEE-488 instruments, permits configuration of very compact systems which can go into applications impractical for earlier generations of systems.

Operator Skill Spectrum

In test and measurement systems applications the computer skills of the operator typically range from moderately high to zero. Laboratory applications are frequently interactive, where the engineer/programmer/operator are all the same person. On a production test station, operator computer skills are low. Unattended testing has no operator by definition. The 4041 controller was designed, with options and peripherals, to fit these differing needs. The standard 4041 is an "execute only" controller; it can only run previously developed programs. The operator cannot tamper with programs, or even list them. The standard 4041 is non-intimidating, with operator interaction limited to reading prompts from the alphanumeric display, inserting a DC 100 tape cassette, and pressing a small number of keys. Extensive error handling and trapping capabilities can keep the system from "crashing" in almost all situations. Hard copy, perhaps for applications such as failure tags to be attached to a defective unit under test, can be automatically generated on the built-in printer. Up to four ports, two IEEE-488 and two RS-232, permit networking to host computers, up to 28 IEEE-488 instruments, or even segregation of fast and slow instruments onto two busses to maximize throughput.

At the sophisticated end of the operator spectrum, an RS-232 CRT terminal attached to a 4041 with program development ROM packs (Option 30) provides a flexible interactive workstation for the sophisticated programmer. Peripherals such as printers, plotters, and mass storage add further power. This configuration would be typical in research labs, or for the test engineer to develop programs which will then be run by lower skilled operators on the production line with execute-only 4041s.

Programmer Skill Spectrum

Most test programs are written by "electronics types", not computer science majors. Many test engineers write programs only occasionally, and later modifications and maintenance are frequently done by a second party since "the guy who wrote the program doesn't work here anymore".

At the other end of the spectrum, however, are complex requirements demanding a team approach to writing the program and sophisticated and powerful techniques to maximize memory utilization and minimize run time.

BASIC is an excellent language for the occasional programmer, and was chosen for the 4041. Its English-like commands, simple syntax, and line-by-line interpreter implementation combine for friendly, easy use. To improve the self-documenting characteristics and thus reduce maintenance costs, 4041 BASIC is enhanced by several features. Variable names may be up to 8 characters, allowing the programmer to select meaningful names like RISETIME, VOLTAGE1, or DELAY. Subprograms and program lines may be named, with examples such as SRQHNDL or CALCRMS.

Simple BASIC leaves much to be desired for most sophisticated programmers. 4041 BASIC includes many enhancements such as FORTRAN-like subprograms. Variable passing from main to subprograms and the ability to declare any variables as local or global means that a team of programmers can work quite independently on a massive task, with the main program ultimately being not much more than a series of subprogram CALL statements. Other powerful features include optional data types (short and long floating point plus integer), a COMPRESS command to optimize memory use, a proceed mode which overlaps I/O and processing operations for maximum system speed, logical unit assignment capability, and up to 160k bytes of memory directly addressable without overlays or paging techniques.

4041 Architecture

The 4041 controller contains three micro-processors, with the CPU being the powerful 16-bit 68000. Standard memory is 32k bytes (approximately 25k user-available), with optional 32k increments to 160k maximum. A 20-character alphanumeric LED display, 20 character thermal printer, DC-100 cassette drive, 18 function keys, an IEEE-488 port, and a RS-232 port are standard. A real time clock and calendar capability are standard on the 4041. Option 01 adds a second pair of ports (one IEEE-488 and one RS-232). The Option 01 IEEE-488 port has Direct Memory Access capability. Other options include an 8-bit parallel TTL port, (Option 02) the program development ROMs and carrier (Option 30), and a program development/debug keyboard (Option 31). Options 30 and 31 could thus let a test engineer easily and temporarily convert an installed execute-only 4041 into a debug/edit mode, make necessary program changes, and restore it to the tamper-proof condition. Extensive program development, however, would normally be accomplished at a programming station consisting of an

Option 30 4041 plus a CRT terminal to permit multi-line viewing of program listings.

The 4041 package is a compact monolithic unit of identical height and width to the TM 5003 Power Module. A 4041 and TM 5003 can be easily fastened together and used on the bench or rack-mounted as a single unit, leading to extremely compact system configurations suitable for crowded benches and racks or use in vans, ships, and aircraft.

Test and Measurement Orientation

The 4041 controller was developed simultaneously with the TM 5000 instrument family, and optimized as an instrument controller. Many of the IEEE-488 functions are simple high level commands in 4041 BASIC. Examples include ATN, GET, LLO, and several others. In its power-up default condition, the 4041 implements Tektronix *Codes and Formats* standard and thus can communicate instantly with Tektronix IEEE-488 instruments without any programmer attention to formats, syntax, delimiters, number format, etc. However, the 4041 also has virtually complete, programmable control over every IEEE-488 line and condition. When this ability is combined with the 4041's Logical Unit assignment and stream specification ability, virtually any IEEE-488 instrument or device can be easily handled. The stream specification ability means that a particular device's format, syntax, end-of-message character, and other idiosyncrasies can be described one time in a Logical Unit assignment statement. Thereafter, the programmer can control or obtain data from that instrument as easily as from an instrument which fully complies with Tektronix *Codes and Formats* Standard.

The error trapping and handling capabilities of the 4041 are of particular importance in test and measurement systems. Virtually any category of error — in instruments, peripherals, on the bus, or even within the 4041 — can be trapped and handled by software drivers. When coupled to the powerful self-diagnostics and error reporting features of TM 5000 instruments, very fault-tolerant systems can be configured which demand little or no operator skill.

Front Panel Keyboard

System Keys

AUTO-LOAD — Causes the internal magnetic tape to rewind and find the "AUTOLOAD" program. This program is then loaded into memory and execution begins.

ABORT — Halts program execution if no user-specified handler routine is called by the program. If a handler routine is specified for the ABORT key, program control is passed to that routine.

PROCEED — Performs one of the following functions depending on equipment or program state:

1. Causes program execution to start at the next program line if a PAUSE was encountered.
2. Resumes execution after an ABORT. If a program is loaded from the tape, execution starts from the first program line.
3. Delimits user input when requested from an INPUT statement.

CLEAR — Clears the alphanumeric display. Does not clear user-defined prompts or the input cursor from an INPUT statement.

EEX — Causes the number requested by an INPUT statement to be entered in scientific notation. Numbers entered after pressing the EEX (Enter Exponent) key are considered part of the exponent.

PAUSE — Halts the program after executing the current line. If the current program line is an INPUT statement, the program stops before the execution of INPUT.

User-Definable Function Keys

Ten numeric user-definable function keys, 0-9, can be assigned subroutines by the applications program. The keys may be re-defined by the program during execution to allow for unlimited user routines. The function keys can be enabled or disabled under the control of a program.

Numeric values are assigned to these keys for entering information requested by an INPUT statement. When input has been completed, user functions assigned to these keys are re-enabled.

The other two keys on the front-panel keyboard are the decimal key (".") and the minus ("−") key. The decimal key is provided for decimal point entry associated with numeric and the minus key is used to enter negative numbers associated with numeric.

Keyboard overlays may be used for labeling the function keys with a number or an abbreviation of the user routines.

Front-Panel Display

The front-panel display communicates test procedures and operator prompts and displays intermediate or final program results. The display is fully programmable.

Alphanumeric Display

Twenty character alphanumeric line
Sixteen segment LED
Size: height: 4.1 mm (0.16 in) width: 3.3 mm (0.13 in)
Characters per cm: 1.6 char. per cm (4 char per in)
Sixty-four character symbols
Message viewing time: programmable
Scrolling rate: programmable

System Indicators

Four LEDs located on the display front panel indicate the status of the system.

BUSY —

Indicates that a program is running. A blinking BUSY light indicates that the system has PAUSED (temporarily halted).

POWER —

Indicates the machine is on.

I/O —

Indicates that an Input/Output operation is being performed.

FN —

Indicates that the user-definable function keys are enabled.

Magnetic Tape Drive

The magnetic tape drive is used to store user's programs and data. The tape is the primary means of loading programs, particularly for execute-only applications; in addition, the tape drive provides for long-term unattended data logging. File security is programmable.

File Structure — 48 named files (max).

Capacity (physical records) — 650 typical (600 min).

Physical Record — 256 bytes.

Average Transfer Rate — 13,324 bits per s.

Search Speed — 60 in/s 1520 mm/s.

Tape Rewind — 60 in/s 1520 mm/s.

Tape Cartridge — DC 100 cassette.

PRINTER

The printer produces hard copies of the intermediate or final program results, operator prompts, and changes in variables or system status. Messages longer than twenty characters are printed on succeeding lines where the user can specify the appropriate indentation for better delineation and readability.

Printing Method — Thermal, fixed head.

Capacity — 20-character alphanumeric line.

Font — 5 x 8 dot matrix printed.

Character Size — 2.5 mm high x 1.8 mm wide (.10 in high x .07 in wide).

Line Spacing — 4.23 mm (6 lines per in).

Printing Speed — 1.8 lines/s.

Feed Speed — 8.46 mm per s (.34 in/s).

Character Set — 26 Uppercase letters
26 Lowercase letters
10 Numeric digits
34 Special characters
32 Control characters

128 Total

Paper Size — 60 mm x 25 m (2.36 in x 82 ft)

CONTROLLING THE BUS

The 4041 automatically controls all bus management signals in the proper sequence for the desired interface task and instrument interaction.

A bus management function program that uses direct IEEE-488 mnemonic commands accommodates differences in implementation of GPIB on other equipment. Virtually all legal bus states can be programmed this way, which affords a high degree of flexibility for addressing various system applications.

BUS INTERRUPTS

The 4041 has the ability to detect and respond to various types of interrupt conditions that can be generated in the GPIB. User-specified software handlers can be written to perform various tasks when these conditions occur. Interrupts can be programmably ENABLED or DISABLED.

Interrupt conditions are:

| Mnemonic | Message |
|----------|-----------------------|
| SRQ | Service Request |
| EOI | End or Identify |
| IFC | Interface Clear |
| DCL | Device Clear |
| GET | Group Execute Trigger |
| TCT | Take Control |
| MTA | My Talk Address |
| MLA | My Listen Address |

BUS COMMUNICATION

Interface and bus device addressing are programmable. This allows the user to direct message and data flow to and/or from the appropriate interface and GPIB peripheral. Information such as primary and secondary addressing, along with pertinent device-dependent information, can be attached to a specific logical unit number. Subsequent communication with that GPIB device can be directed to the logical unit, eliminating the need for redundant or repetitious statement programming.

TRANSFER RATES (IEEE-488)

Transfer rates for the standard interface are given below.

| | Input | Output |
|----------------|--------------------------|--------------------------|
| Interrupt Mode | Exceeds 5k Bytes/s | Exceeds 5k Bytes/s |
| Fast Mode | Exceeds 16.5k Bytes/s | Exceeds 19.5k Bytes/s |

SERIAL INTERFACE

The 4041 comes with a standard serial asynchronous RS-232C interface. The 4041 can support applications requiring terminals, modem/host communication, or instrumentation with this interface protocol.

In addition to standard transmission rates from 75 to 9600 baud transmission rates are programmable to any integer ranging from 2 to 9600 baud.

Full Duplex — Full Capability (half duplex not supported)

Transmit/Receive — Matched rate only

Bits Per Character — 5, 6, 7, or 8 bits

Stop Bits — 1 or 2

Parity — Even, Odd, One, Zero, None

Error and Interrupts

Conditions such as parity, framing and overrun errors, receipt of data or data available, and BREAK can all be programmably captured. User routines or handlers can then direct what action should be taken, depending on the particular condition.

The end of message delimiter (EOM) can be programmable to any one or two character ASCII string. This enables the 4041 to communicate with most hosts or peripherals via the serial interface.

Reliability/Self-Test

SELF-TEST

An integral part of the 4041 is the self-test feature, which assures the user of reliable operation. Self-test is executed automatically on power-up and performs extensive hardware and operating system tests.

SYSTEM VERIFICATION

The system verification tape is a standard accessory that tests 4041 components not covered by the self-test. These include front-panel controls and indicators, and the optional program development keyboard. Interface line drivers can be tested, if necessary, by connecting loopback connectors.

DYNAMIC RANGE

Long Precision Numeric — $2.2E \pm 308$

Short Precision Numeric — $9.0E \pm 307$

Integer — -32760 to $+32767$

Character String Length (max) — 32767

Array elements (real, integer or character arrays) — 32767 elements maximum per row (or column); limited by total memory installed

POWER REQUIREMENTS

Line Voltage — 100 – 120, 200 – 240 Volts AC $\pm 10\%$

Line Frequency — 48 – 66 Hz

Power Consumption — 120 Watt (max)

ENVIRONMENTAL CHARACTERISTICS

Operating Temperature — 0° to 55°C (32° to 131°F) without data cartridge or printer paper. 0° to 45°C (32° to 113°F) with data cartridge or printer paper.

Storage Temperature — -40° to 75°C (-40° to 167°F) without data cartridge or printer paper.

Humidity — 85% relative non-condensing, 0° to 45°C (32° to 113°F) — 20% to 80% condensing.

Altitude (operating) — 4.5 km (15,000 ft).

EMI — Meets FCC Part 15, Subpart J, Class A and VDE 0871 Class B.

PHYSICAL CHARACTERISTICS

Dimensions —

Height — 180 mm (7.2 in).

Width — 212.5 mm (8.5 in).

Length — 446.2 mm (20.75 in).

Weight —

Standard Net Weight — 7.70 kg (17 lb 5 oz).

With Options Net Weight — 8.69 kg (19 lb 5 oz).

ORDERING INFORMATION

4041 Controller \$4995

Option 01 Second GPIB and RS-232 Add \$1600

Option 02 TTL Interface 8 bit parallel interface .. Add \$800

Option 20 Added memory 64K byte total Add \$1850

Option 21 Added memory 96K byte total Add \$2625

Option 22 Added memory 128K byte total Add \$3350

Option 23 Added memory 160K byte total Add \$3950

Option 30 Program Development ROMs and

ROM Carrier Add \$995

Option 31 Program Development Keyboard Add \$750

FIELD INSTALLED MODIFICATIONS

4041-F01, Option 01 \$1800

4041-F02 Option 02 \$1000

4041-F30 Option 30 \$995

4041-F31 Option 31 \$750

040-1021-00 First expansion from standard configuration

(32k bytes for total of 64k bytes) \$2050

040-1022-00 Memory Expansion of 32k byte increments

above 64k byte total \$800



4051

GPIB
IEEE-488

System Controller

11 Inch DVST Display

Graphic Enhanced BASIC

GPIB Compatible

Built-in Tape Drive

Expandable Memory (to 32K)

Optional RS-232 with Terminal Mode



4052

GPIB
IEEE-488

System Controller

11 Inch DVST Display

Graphic Enhanced BASIC

GPIB Compatible

Expandable Memory (to 64K)

RS-232 and Terminal Mode Option

High Speed 16-bit, Bit-sliced Processor



4054

GPIB
IEEE-488

System Controller

19 Inch DVST Display

Enhanced High Resolution Graphics

Dynamic Graphics Option

Thumbwheel Controlled Crosshair Cursor

Expandable Memory (to 64K)

GPIB and RS-232-C Compatible

See pages 79 and 80 for additional information on controllers.

MAINFRAMES

The new TM 5000 Programmable Instrument Plug-ins operate in either of two power-module mainframes. One of the mainframes is a half rack width power-module capable of accepting three single width plug-in instruments at one time. The other power-module can provide power for up to six single wide plug-in instruments at one time. While TM 5000 Instruments will operate only in these TM 5000 power-modules, over 40 TM 500 manual plug-in instruments will operate in these same mainframes. Since this is so, it is possible to utilize the TM 5000 Mainframes for either all programmable systems or for hybrid systems using both programmable and manual instruments.

While the TM 5000 power-modules are used for GPIB compatible plug-ins, the power-modules themselves do not occupy a bus address location. Each module has its own bus address, and the inter-connect scheme will allow as many as six (typically three) instruments to be connected to the system with only one GPIB cable.

NEW

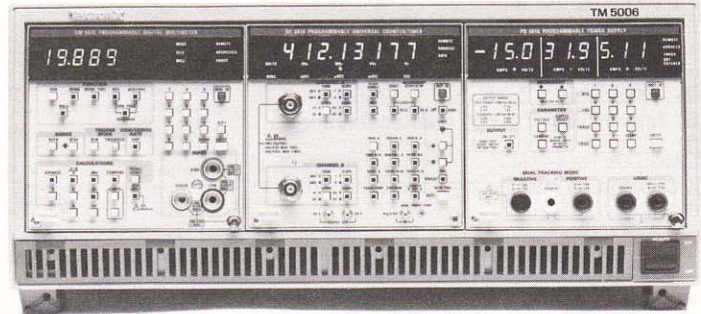

TM 5006

The TM 5006 can accept and provide power for up to six single widths of TM 5000/TM 500 Plug-ins. The right hand compartment is a high power compartment. The power module features a pulse width modulated switching dc power supply. All dc voltages are electronically regulated. The TM 5006 has forced air cooling.

Six individual connectors, one for each compartment, provides connections to each GPIB compatible plug-in. These connectors feed a GPIB interface board, then to a standard GPIB connector on the rear panel. All GPIB connections are separate from the board rear interface connector.

Option 10 provides rack mounting capability. 040 kits also available to field convert standard to rack mount and rack mount to standard.

POWER REQUIREMENTS

Line Voltage Ranges — 100, 110, 120, 200, 220 and 240 V; not to exceed 250 V on 240 V range. Range changing accomplished by moving an easily accessed internal jumper.

Line Frequency Ranges — 48 to 60 Hz.

Power Consumption — Maximum primary power \approx 650 VA. Actual power consumption depends on plug-in selection and operating modes.

RACKMOUNT-TO-CABINET AND CABINET-TO-RACKMOUNT CONVERSION KITS

Cabinet-to-rackmount conversion kit, equipped with slide out assembly, required to convert a TM 5006 to rackmount capability.

Order 040-0982-00 \$125

Rackmount-to-cabinet conversion kit, equipped to convert a TM 5006 with rackmount capability to cabinet style.

Order 040-0983-00 \$60

Cabinet-to-rackmount conversion kit, equipped with slide-out assembly to rackmount a 4041 Instrument Controller to the left of a TM 5003.

Order 040-0984-00 \$150



TM 5003

The TM 5003 can accept and provide power for up to three single widths of TM 5000/TM 500 plug-ins. The power module features a pulse width modulated switching dc power supply. All dc voltages are electronically regulated. The TM 5003 has forced air cooling.

Three individual connectors, one for each compartment, provides connections to each GPIB compatible plug-in. These connectors feed a GPIB interface board, then to a standard GPIB connector on the rear panel. All GPIB connections are separate from the board rear interface connector.

Field modification kit is available to rackmount the TM 5003 with the 4041 Instrument Controller.

POWER REQUIREMENTS

Line Voltage Ranges — 100, 110, 120, 200, 220 and 240 V; not to exceed 250 V on 240 V range. Range changing accomplished by moving an easily accessed internal jumper.

Line Frequency Ranges — 48 to 60 Hz.

Power Consumption — Maximum primary power \approx 300 VA. Actual power consumption depends on plug-in selection and operating modes.

| Dimensions | TM 5003 | | TM 5006 | |
|------------|---------|------|---------|------|
| | mm | in | mm | in |
| Height | 7.63 | 19.4 | 7.63 | 19.4 |
| Length | 18.7 | 47.6 | 18.7 | 47.6 |
| Width | 9.1 | 23.0 | 17.5 | 44.5 |
| Weight | kg | lb | kg | lb |
| | 19.0 | 8.6 | 32.0 | 14.5 |
| Ship | 26.5 | 13.0 | 46.0 | 21.0 |

ORDERING INFORMATION

TM 5003 \$700

Option 02 Rear Interface Add \$75

TM 5006 \$950

Option 02 Rear Interface Add \$150

Option 10 Rackmount Add \$120

OPTIONAL ACCESSORIES

GPIB Cable, 2 meter

Order 012-0630-01 \$75

GPIB Cable, 4 Meter

Order 012-0630-02 \$115

Plug-in GPIB Extender Cable

Order 067-0996-00 \$85

TM 500 Plug-ins slide into any one of several power-module mainframes. They are available in six versions accepting one instrument, or combinations up to six. Below are described each of the six mainframes built by Tektronix for TM 500 Instrumentation.

Option 02 Rear Interface for interconnection of instruments at mainframe rear interface. (Option 05 with TM 515).

Option 07 — For operating TR 502, TR 503 and DC 508A Option 07 in a TM 503, TM 504, TM 506, or TM 515.

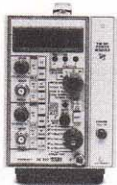

TM 501

Built for use with one single wide plug-in module.

ORDERING INFORMATION

- TM 501** \$285
- TM 501 Option 02 Interface** Add \$55

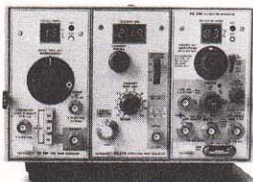

TM 503

Accepts up to three single wide TM 500 Plug-ins. This lightweight, portable, benchtop mainframe includes a front panel power switch and tilt bail. Also fits easily into the shelf of a TEK Model 3 Lab Cart. A carrying case is available to protect the mainframe during transportation.

ORDERING INFORMATION

- TM 503** \$285
- TM 503 Option 02 Interface** Add \$75
- TM 503 Option 07 Interface** Add \$25

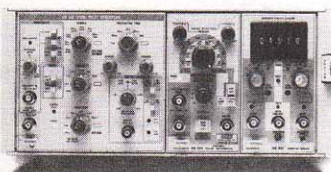

TM 504

The TM 504 can be fitted with up to four different TM 500 Plug-ins. This mainframe is designed to fit into the shelves of the TEK Model 3 Lab Cart for complete test station mobility. Each TM 504 Mainframe also comes equipped with front panel switch, tilt bail and a handle. An optional carrying case is available for transportation to and from the worksite.

ORDERING INFORMATION

- TM 504** \$315
- TM 504 Option 02 Interface** Add \$100
- TM 504 Option 07 Interface** Add \$25

MAINFRAMES DIMENSIONS & WEIGHTS (without Plug-ins)

CABINET

| | TM 501 | | TM 503 | | TM 504 | | TM 506 | | RTM 506 | | TM 515 | |
|------------------------|--------|------|--------|------|--------|------|--------|------|---------|------|--------|------|
| Dimensions | in | cm | in | cm | in | cm | in | cm | in | cm | in | cm |
| Height | 6.0 | 15.2 | 6.0 | 15.2 | 6.0 | 15.2 | 6.0 | 15.2 | 5.25 | 13.3 | 6.8 | 17.3 |
| Width | 3.9 | 9.9 | 8.7 | 22.1 | 12.0 | 30.5 | 17.4 | 44.2 | 19.0 | 48.3 | 15.0 | 38.1 |
| Length | 15.3 | 38.9 | 17.0 | 43.2 | 20.0 | 50.8 | 20.0 | 50.8 | 18.9 | 48.0 | 20.0 | 50.8 |
| Weight (approx) | lb | kg | lb | kg | lb | kg | lb | kg | lb | kg | lb | kg |
| Net | 5.4 | 2.4 | 9.5 | 4.3 | 18.5 | 8.4 | 29.0 | 13.2 | 32.0 | 14.4 | 22.5 | 10.2 |
| Domestic Shipping | 13.0 | 5.9 | 17.0 | 7.7 | 26.0 | 11.8 | 41.0 | 18.6 | 46.0 | 21.0 | 30.0 | 13.6 |



TM 515

The TM 515 Traveler Mainframe is designed to protect up to 5 separate instruments during transportation to and from the worksite. Included with this rugged mainframe are pop-off front and back covers which protect the instruments and also store accessories. The Traveler Mainframe will slide easily under an airline seat when traveling and comes equipped with a heavy duty handle and tilt bail.

ORDERING INFORMATION

- TM 515** \$455
- TM 515 Option 05 Interface** Add \$75
- With Option 06 48-440 Hz fan** Add \$150
- TM 515 Option 07 Interface** Add \$25

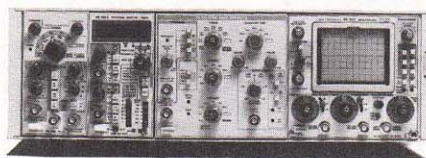

TM 506

This mainframe can power up to 6 different plug-in's, providing a complete test station with one power cord. Like most TM 500 Mainframes, the TM 506 is available with the Option 02 which allows rear-interfacing of different modules, reducing front panel clutter.

ORDERING INFORMATION

- TM 506** \$440
- TM 506 Option 02 Interface** Add \$150
- TM 506 Option 07 Interface** Add \$25



RTM 506

The RTM 506 is a rackmount version of the TM 506. It contains all the same features with the added front panel handles and rackmount rails for built-in configurable test stations. This mainframe saves you space and money in tight situations.

ORDERING INFORMATION

- RTM 506** \$560
- RTM 506 Option 02 Interface** Add \$150

POWER REQUIREMENTS

Line Voltage Ranges — International Transformer: 100, 110, 120, 200, 220, 240 V ac, all within 10%; but not to exceed 250 V ac. Range changing for transformer accomplished with quick-change line-selector block.

Line Frequency Ranges — International Transformer: 48 Hz to 440 Hz.

NOTE: The ventilating fans on the TM 506 and TM 515 operate on 48-60 Hz only.

Power Consumption — Max primary power approx: 35 W for TM 501, 120 W for TM 503, 220 W for TM 504, 320 W for TM 506, and 240 W for TM 515. Actual power consumption depends on plug-in selection and operating modes.

SUPPLIES (UNREGULATED)

Shared by All Compartments — +33.5 V dc and -33.5 V dc. TM 501: 500 mA max. TM 503: 1 A max. TM 504: 1.4 A max. TM 506: 2.1 A max. TM 515: 1.8 A max.

Low Power Compartments — Two 25 V ac windings, 500 mA each supplied to each compartment, independently. 17.5 V ac and +11.5 V dc shared in any combination between these two supplies and among all low-power compartments. TM 501: 1 A max. TM 503 and TM 504: 3.6 A max. TM 506: 6.5 A max. TM 515: 6.5 A max.

High Power Compartments — (nearest to switch in TM 504 and TM 506): Two 25 V ac windings, 1 A each. 17.5 V ac and +11.5 V dc, 4 A max, shared in any combination between these two supplies.

TEMPERATURE RANGE

Operating — 0°C to +50°C.

Nonoperating — -40°C to +75°C.

ALTITUDE RANGE

Operating — To 15,000 ft.

Nonoperating — To 50,000 ft.

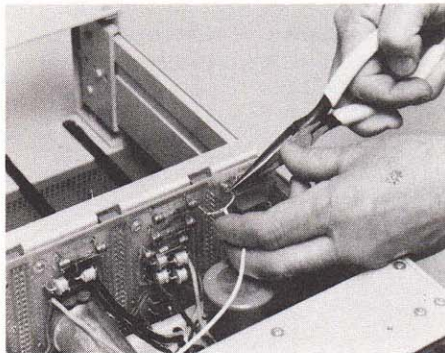

**REAR INTERFACE
CAPABILITY WITH TM 500 and 5000**

TM 500 and TM 5000 Mainframes offer the unique ability to have separate modular instruments interconnected through the rear interface board of each mainframe. For example, the rear trigger output of a signal source can be interconnected to the rear input of a counter for instant frequency checks at the touch of a front-panel switch. Or, a digital multimeter and power supply may be interconnected to speed precise voltage set-ups without any need to move test leads. Any module can be internally connected thru the mainframe and can also be externally interfaced out the back panel.

Most TM 500 and TM 5000 Plug-in modules contain a duplication of the front panel input and output connections in the back. These interface lines are built into the rear-edge circuit card connector of each plug-in. Some modules also have additional signal or control lines which are present only at the back of the instrument. In either case, different modules may be interconnected by the user to reduce front panel clutter or to perform functions not otherwise available.

Mainframes can be interfaced a variety of ways. A user can solder together the appropriate connector pins on a standard mainframe, or can order the mainframe with the Option 02. The Option 02 version of the mainframe comes equipped with square pin connectors on the rear interface circuit board and a special wire kit consisting of standard wires and coaxial cables with mating square pin receptacles. Option 02 also provides a rear-panel male connector, mating cable connectors, and one BNC connector per plug-in compartment.

The square pin connectors eliminate the need to hand-solder connections to the interface circuit board, extending the life of the mainframes. The remaining Option 02 components offer a variety of interfacing alternatives limited only by the user's ingenuity and imagination.

The TM 515 Mainframe is available with an Option 05 interface which includes everything in the Option 02 except for the rear panel 50-pin male connector, mating cable connector and the BNC connectors.

Tektronix also makes a low-cost "do-it-yourself" Rear Interface Modification Kit. It enables those who don't need the full flexibility of factory installed interface pins at every connector to install

a limited rear interface on any TM 500 and TM 5000 Mainframe except the TM 501. The kit includes fourteen square pins, and 3 coaxial cables, all with female pin receptacles. Installation instructions also included. For "do-it-yourself" modification kit

Order 040-0846-01 \$30

Tektronix has published a Rear Interface Data Book that contains information on the interfacing capability of each instrument "family." This book is available through Tektronix by filling out a card included in each mainframe package.

**CABINET-TO-RACKMOUNT
CONVERSION KITS AND
MONITORS**

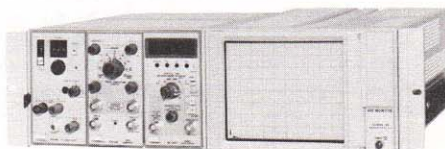

Cabinet-to-rackmount conversion kit, equipped with slide-out assembly, required to rackmount two TM 503s side-by-side in a standard rack width.

Order 040-0616-02 \$110

Cabinet-to-rackmount conversion kit, equipped with slide-out assembly, required to rackmount a single TM 503 in a standard rack width. This includes securing hardware and a blank front panel when only one instrument is utilized.

Order 040-0617-02 \$150

Rackmount-to-cabinet conversion kit equipped to convert a rackmount TM 503 to a cabinet style.

Order 040-0618-01 \$55

Cabinet-to-rackmount conversion kit, equipped with slide-out assembly, required to rackmount a TM 503 and a 603, 603A, 604, 604A, 605, 606, 606A, 607, 607A, 608 or 624 in a standard rack width.

Order 040-0624-01 \$90

Cabinet-to-rackmount conversion kit, equipped with slide-out assembly, required to convert a TM 506 (cabinet style) to an RTM 506.

Order 040-0761-04 \$120

Rackmount-to-cabinet conversion kit, equipped to convert an RTM 506 to cabinet style TM 506.

Order 040-0762-00 \$75

TEK LAB CART MODEL 3



This Lab Cart is especially designed for rollabout configuration combining TM 500 Instrumentation with the Tektronix Oscilloscope of your choice. It features pistol-grip tilt control and a large accessory drawer in the base. The top tray accepts any TEKTRONIX 7000 Series, 5000 Series, or Portable Oscilloscope. The MODEL 3 comes standard with one lower shelf that will support either a TM 503 or TM 504 with plug-ins. Additional shelves are available as optional accessories. Max capacity of the lower shelf area is two TM 503s or TM 504s, stacked, or up to a TEKTRONIX 7000 Series Oscilloscope in size—with TM 500 packages placed on the tray at your option. The power distribution module at rear underside of the top tray provides four power outlets and a 15 foot line cord.

International modification (Option 01) deletes power distribution module.

TEK Lab Cart Model 3 \$475

With Option 01 (International Modification) No Charge

Additional Lower Shelf,
Order 436-0132-01 (TM 500 only) \$35

Safety Belt to secure oscilloscopes or TM 500 to top tray or lower shelves (not needed for 5000 or 7000 Series on top tray).

Order 346-0136-01 \$23

TM 500 APPLICATION AND CONSTRUCTION NOTES

The TM 500 product line is supported by an on-going program to keep you informed of how to achieve optimal performance and versatility from your TM 500 Instruments. Tektronix' goal of providing you with solutions to difficult measurement problems does not end with your purchase of TM 500 Instruments.

Application Notes take you through the steps necessary to solve complex problems, or to make more useful measurements with your TM 500 instruments. Subjects include integration through v to f conversion, generating delayed pulses, and current sinking with power supply modules.

Construction Notes provide information necessary to build custom circuits using a TM 500 Blank Plug-in Kit and standard components. These notes are developed from the actual construction of more common special circuits; they include parts lists, schematics and other construction details. Some of the available notes include: power supply circuits, thermal true RMS converter, and analog multipliers

PLUG-IN STORAGE COMPARTMENT

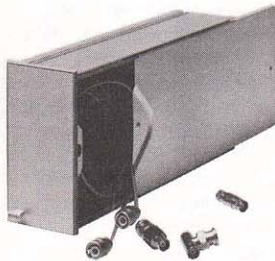

An electronic engineer or technician away from his bench seldom has enough storage space for probes, cables, "tees", accessories, and small tools. The plug-in storage compartment is a useful adjunct to many rollabout and Travel Lab configurations. If all five compartments in your TM 515 Traveler Mainframe are not used for a particular field application, add a plug-in storage compartment for extra convenience. Even a rackmount TM 500 installation might profit by readily-available terminators or attenuators in a presently unused compartment. Compatible with all TM 500 Mainframes, 5000 Series Oscilloscope Mainframes, and 203 and 204 SCOPE-MOBILE® Cart plug-in storage bins; inside dimensions 25 cm L x 5.1 cm W x 10.6 cm H, (9 7/8 in L x 2 in W x 4 1/4 in H).

Order 016-0362-01 \$95

TM 500 CUSTOM PLUG-IN KITS

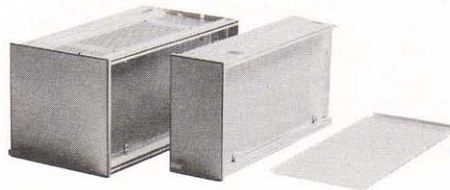

Single and double compartment sizes

A complete test and measurement set-up for many typical jobs requires at least one nonstandard item. Such items commonly include relay circuits or manual switches for routing signals; test oscillators at pre-set frequencies for alignment purposes and markers; digital logic circuits for sequencing, timing, and control; special processors or converters such as log amps, multipliers, and analog-to-digital converters; and a variety of other system elements which are usually not available or economical as complete commercial instruments. The construction and packaging of these special items is always a problem, and the sheet metal work and provision for necessary power supplies often far exceed the cost of the functional elements.

This is why the TM 500 line includes custom plug-in kits. The kits provide perforated main circuit boards which allow rapid construction and wiring of circuits using both discrete components and integrated circuits. Also included are top and bottom rails, side cover, front sub-panel, and a blank dress panel, and the latch mechanism. An instruction sheet details the voltages and currents available in the power module. Standard voltage regulator ICs can be used to provide exact voltages for most individual power supply requirements. The finished special-purpose circuitry or instrument is physically compatible with other TM 500 Instrumentation.

Single Compartment with Power Supply

Now a blank plug-in kit complete with power supply parts and circuit board layout is available. A single-wide compartment, this plug-in kit saves set up time and build time as the power supply circuitry is designed and kitted for you.

Specifically, the supplies parts are:

- (1) A ground-referenced positive supply, capable of +7 V to +20 V at up to 400 mA. (Adjustment is centered at 15 V; change of resistor values required for total 7-20 V range).
- (2) A ground-referenced negative supply, identical to supply No. 1 except for polarity.
- (3) A ground-referenced supply nominally 5 V, not adjustable, with current capability up to 1 ampere.

A series of TM 500 Construction Notes provide direction for building custom circuits using the TM 500 Blank Plug-in Kits and standard components. Among the construction notes available are: Suggested power supply circuits, thermal true RMS converter:

| | |
|---|-------|
| Custom Plug-in Kit with Power Supply (single compartment) 040-0803-02 | \$90 |
| Custom Plug-in Kit (single compartment) 040-0652-05 | \$75 |
| Custom Plug-in Kit (double compartment) 040-0754-07 | \$100 |
| Single Compartment without ECB 040-0821-03 | \$60 |

TM 500 BLANK PANEL



When operating the TM 500 Instruments with less than the full complement of plug-ins, the blank plug-in panel can be used to cover unused compartments.

Blank Plug-in Panel, Order 016-0195-03 \$21

FRONT-PANEL CIRCUIT BOARD ADAPTER KIT PS 501-1 or PS 503A

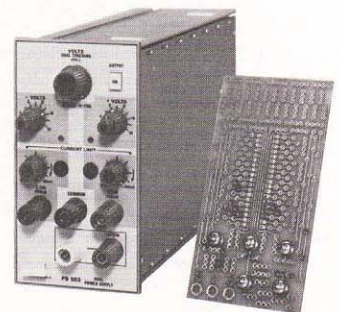

The front-panel circuit-board kit is a convenient way to mount small experimental circuits or fixtures right on the front of a TM 500 Power Supply.

Typical applications for the adapter are as a device tester (test fixture), educational demonstrator (especially ICs), and in temporary systems functions, e.g., OR'ing and AND'ing two signals. This adapter will supplement the blank plug-in kit for simple or temporary applications.

The adapter kit provides a convenient platform for building up circuits; its pin holes are pre-solder-flowed and some are interconnected. Discrete devices can be readily attached to the adapter kit board, stored, and easily reattached to the "banana jack" plugs on the face of the power supply. Circuit clips for interconnected pin holes are available from Tektronix. The adapter kit is 2.5 inches wide.

Order 013-0152-00 \$22

AM 501 AUXILIARY CIRCUIT BOARD KIT

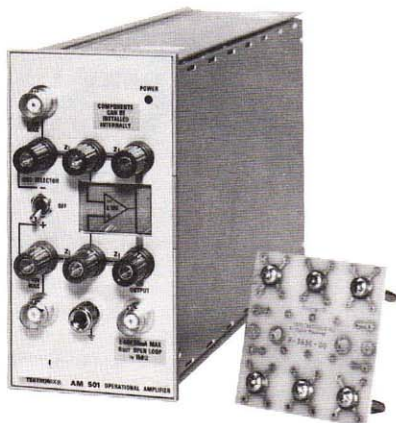

The AM 501 Auxiliary Circuit Board Kit attaches to the input and output terminal plugs on the front of the AM 501 Operational Amplifier. The kit is approximately 2.5 inches square. The kit is a pc board which has six terminal studs for attachment to the amplifier's banana jacks. This permits the designer to build a circuit of resistors, capacitors, and other components for use in conjunction with the AM 501's input, output, or feedback circuits. With several boards, the AM 501 Op Amp circuit can be changed instantly in configuration from integrator to differentiator to amplifier.

An additional advantage of the kit is that it does not interfere with the other connectors on the face of the AM 501.

Order 013-0146-00 \$22

Type 1105 Battery Power Supply



TM 500 Instruments may be operated with the Type 1105 when suitable ac line power is not available. The 1105 is rugged and portable, operating on internal batteries or an external dc source. Operating time is dependent on the number and type of plug-ins being powered, and their operating mode. The following table shows estimated operating time for a full power module in a typical situation.

| | |
|--------------|-----------|
| TM 501 | 5.0 hours |
| TM 503 | 1.6 hours |
| TM 504 | 1.3 hours |
| TM 506 | 0.9 hours |
| TM 515 | 1 hour |

ORDERING INFORMATION

1105 Battery Pack \$1240
 Option 01, 230 V operation No Charge

**MANUAL (ONE SHOT) TRIGGER GENERATOR
 RG 501,
 PG 501,
 and
 PG 505**



The Manual (one shot) Trigger Generator is a self-contained, battery-operated, handheld device for manually generating a single pulse. This adapter is used to start a pulse, ramp, sweep, or complete sequence of events on instruments which do not have a manual trigger button or where a remote operation capability is desired, such as some oscilloscopes and the FG 501A, PG 501, PG 505, and RG 501.

The internal trigger generator circuitry eliminates contact bounce, but will generate pulses as rapidly as the operator can manually cycle the pushbutton.

The output pulse is nominally two milliseconds in width and three volts in amplitude with a rapid rise and fall. Output impedance is low (50 Ω); the pulse amplitude drops from about 3.6 to 1.8 volts when changed from a high impedance to a 50 Ω termination. Both voltages decrease with battery aging. The battery is a 5.4 V dry cell.

Applications for the trigger generator also include stepping or sequencing of digital systems, analog control systems, mechanical devices, as well as obtaining "single shot" operation from many types and brands of instruments. Biological and physical experiments, where manual triggering is required as a part of the stimuli, are also common applications.

Order 016-0597-00 \$125

RAIN COVERS



These soft, weather-proof, vinyl-coated Rain Covers come in sizes for TM 503 and TM 504 packages of instrumentation, and include adequate space for protective front covers, as well. They feature heavy-duty zippers that open from either end, and include their own carrying handles, offset to compensate for the off-center balancing point of TM 500 instrumentation packages. The color is Tek blue.

ORDERING INFORMATION

TM 504 Rain Cover
 016-0621-00 \$45
 TM 503 Rain Cover
 016-0620-00 \$35

PROTECTIVE FRONT COVER



A snap-on front cover, molded of high impact plastic, is available for the TM 503 (shown above), TM 504, and TM 506 Mainframes. The cover adds 4.5 cm (1.75 inches) to the length of the TM 503, TM 504, and TM 506 Mainframes, and clears the longest knob projections on any of the instruments.

ORDERING INFORMATION

TM 503 Front Panel Cover,
 200-1566-00 \$14
 TM 504 Front Panel Cover,
 200-1727-00 \$15
 TM 506 Front Panel Cover,
 200-1728-00 \$18

MAINFRAME RETAINER BAR

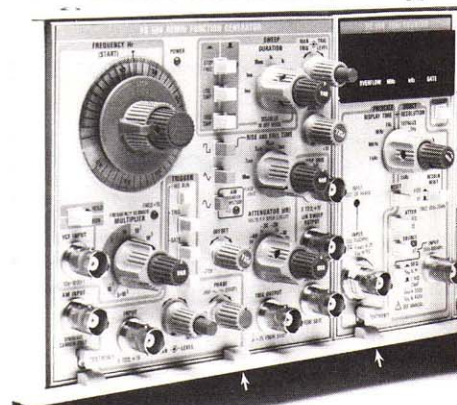

The mainframe retainer bar modification kit comes complete with the retainer bar, all necessary parts and instructions.

You may modify the TM 504 or RTM 506/TM 506 Mainframe: each has a separate kit. Initial installation requires replacement of an existing bottom member of the mainframe with a new part supplied in the kit. Then, the retainer bar can be simply added or removed with four screws, accessible from the bottom of the mainframe.

ORDERING INFORMATION

TM 504—020-0548-00 \$45
 TM 506 and RTM 506—020-0549-00 \$50

TM 500 FLEXIBLE EXTENDER CABLE

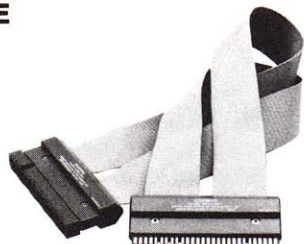

Designed to couple a TM 500 Plug-in with the mainframe rear interface board connection. It provides a completely flexible connecting point outside the mainframe for plug-in operation during test or check-out.

Extender Cable, Order 067-0645-02 \$125

RISE TIME LIMITER



For use with the PG 502 Pulse Generator which has a pulse rise and fall time of less than one nanosecond. In some applications, such as TTL logic where slower rise time is needed, this fast pulse can be limited to six nanoseconds by using the rise time limiter.

Rise Time Limiter, Order 015-0249-00 \$100

P6420 Rf PROBE

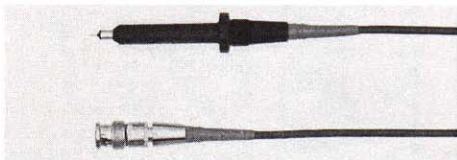

Voltage Range — 5 V to 25 V RMS (70.7 V p-p).

Ac to Dc Transfer Ratio Accuracy — 0.5 V to 5 V RMS $\pm 10\%$ (15° to 35°C). 5.0 V to 25 V RMS $\pm 5\%$ (15°C to 35°C).

Frequency Response — 100 kHz to 300 MHz (± 0.5 dB), 50 kHz to 500 MHz (± 1.5 dB), 10 kHz to 1 GHz (± 3.0 dB).

Input Capacitance — ≈ 3.7 pF.

Maximum Input Voltage — 42.4 V (peak ac + dc).

Temperature Range — Nonoperating: -55°C to $+75^\circ\text{C}$. Operating: $+15^\circ$ to $+35^\circ\text{C}$.

Length — Probe only 9.6 cm. Cable only 2 meters.

INCLUDED ACCESSORIES

- 013-0097-01 1 TIP, probe, retractable (BO)
- 344-0046-00 2 CLIP, alligator (AU)
- 175-0849-00 1 LEAD, ground, 3 in (7.5 cm) (BC)
- 175-1017-00 1 LEAD, ground, 6 in (13 cm) (BE)
- 166-0404-01 1 INSULATING SLEEVE, electrical (CH)
- 352-0351-00 1 HOLDER, probe
- 103-0090-00 1 ADAPTER, BNC female to dual banana (BN)
- 2 TIP, probe replaceable*

*Available in package of 10 only, order 206-0230-03 (CR).

ORDERING INFORMATION

P6420 Rf Probe, 2 m Cable Included, 010-6420-03 \$120

For a 1 meter length cable, (does not change specifications)

175-1661-00 \$26

For a 3 meter length Cable, (does not change specifications)

175-1661-02 \$26

ACCESSORY POUCH



While the TM 501, TM 503, TM 504, and TM 506 Mainframes were designed primarily for bench use, they are frequently carried away for service elsewhere. Taking along the probes, cables, terminators, and other accessories usually required can then be a problem. The soft vinyl accessory pouch neatly solves this problem; sturdy snap-around straps let the pouch be secured to the carrying handle of any TM 500 Mainframe or Tektronix Oscilloscope, or the straps may be snapped together to form a carrying handle for the pouch to be used independently. A convenient side zipper lets accessory items be removed or stored without removing the pouch from the mainframe handle. Dimensions $\approx 9 \frac{1}{4}$ in long x $5 \frac{3}{4}$ in wide x 2 in high.

Order 016-0351-00 \$25

TM 500 CARRYING CASE



These luggage-type carrying cases for TM 500 equipment are molded of high strength glass-epoxy. The TM 503 model weighs 12 pounds empty and measures 23 1/2 inches long by 8 1/2 inches thick by 15 1/2 inches high, including rubber feet, lockable latches, and handle. Inside, the resilient polyurethane foam is molded to accept a TM 503 (with or without the protective front cover) plus either a spare TM 500 family module or a 200 Series Miniscope. A third compartment in the foam accepts miscellaneous cables, accessories, or small tools.

The TM 504 case has a molded foam insert which will accept the TM 504 (with or without the protective front cover) but has no provisions for spare modules or tools. It is 61.0 cm long x 21.6 cm thick x 44.5 cm high, (24 in. long by 8.5 in. thick by 17.5 in. high) and weighs ≈ 14 pounds empty.

ORDERING INFORMATION

Carrying Case for TM 503

016-0565-00 \$335

Carrying Case for TM 504

016-0608-00 \$340

50 Ω PRECISION COAXIAL CABLE



For use with the PG 502, PG 506, end SG 503. These instruments are internally calibrated for use with this 3 ft 50 Ω coaxial cable into a 50 Ω load.

50 Ω Cable, Order 012-0482-00 \$25

HIGH VOLTAGE PROBE FOR USE WITH DMMs



The High Voltage Probe will measure dc voltages from 1 kV to 40 kV with an accuracy of 1% at 25 kV. The division ratio is 1000:1. Common uses include measuring anode voltages on monitors or oscilloscopes.

This probe plugs directly into the front end of the multimeter.

CHARACTERISTICS

| | |
|----------------------|--|
| Voltage range | 1kV to 40 kV dc |
| Input resistance | 1000 M Ω |
| Division ratio | 1000:1 |
| Overall accuracy | 20 kV to 30 kV 2% |
| Upper limit accuracy | Changes linear from 2% at 30 kV to 4% at 40 kV |
| Lower limit accuracy | Changes linear from 2% at 20 kV to 4% at 1 kV |
| Input Z at meter | 10 M Ω required |

Order 010-0277-00 \$115

P6125 COUNTER PROBE 5X



The P6125 is a low-capacitance, 5X attenuation passive probe specially designed for use with counter/timers. It makes possible more accurate time interval measurements of high speed logic signals. Five-times attenuation provides an optimum match between the counter input characteristics and the voltage levels of all common logic families. The low input capacitance permits acquisition of high frequency signals with minimum loading of the circuits under test.

CHARACTERISTICS

Attenuation — 5X.

Input Resistance — 5 M Ω Input.

Capacitance — ≈ 20 pF.

Bandwidth — Dc to 200 MHz.

Voltage Rating — 250 V (dc + peak ac) derated to 35V at 100 MHz.

Cable Length — 1.5 meters.

INCLUDED ACCESSORIES

- 352-0351-00 1 HOLDER, probe
- 013-0107-03 1 TIP, retractable hook
 - * 1 TIP, IC tester
 - ** 2 TIPS, probe
- 344-0046-00 2 CLIPS, miniature, alligator
- 175-0124-01 1 LEAD, ground, 13 cm
- 175-0263-01 1 LEAD, ground, 8 cm
- 166-0404-01 1 SLEEVE, insulating
- 016-0521-00 1 POUCH, accessory

*Available in packages of 10 (015-0201-04) or 100 (015-0201-05) only.

**Available in packages of 10 only (206-0191-03).

P6125 Counter Probe, 5X, 1.5 m, Order 010-6125-01 \$53

CURVE TRACERS

CONTENTS

| | |
|--|-----|
| 576 Curve Tracer System | 302 |
| 172 Programmable Test Fixture | 304 |
| 176 Pulsed High-Current Fixture | 305 |
| 577 Curve Tracer System | 306 |
| 178 Linear IC Test Fixture | 308 |
| 5CT1N & 7CT1N Curve Tracer Plug-Ins | 309 |

Curve Tracers can deliver comprehensive information about a multitude of semiconductor devices and integrated circuits. . . from two- and three-terminal devices through the full range of linear integrated circuits. . . from transistors and diodes to optoisolators, thyristors, and operational amplifiers.

These versatile measurement tools give you more than pinpointed parameters. A curve tracer can show you what happens between specified points in a quickly graphed curve, thus providing the valuable performance data necessary for accurate design, analysis, and evaluation.

If you are well acquainted with Curve Tracers, you will find the Curve Tracer System descriptions (p 302-310) helpful in choosing the system that best meets your requirements. If you would like to receive a brochure, application notes, and other materials to learn more about Curve Tracers and their measurement capabilities, please use the reply card; or, for faster action, contact a Tektronix Sales Engineer at the Sales Office nearest you.

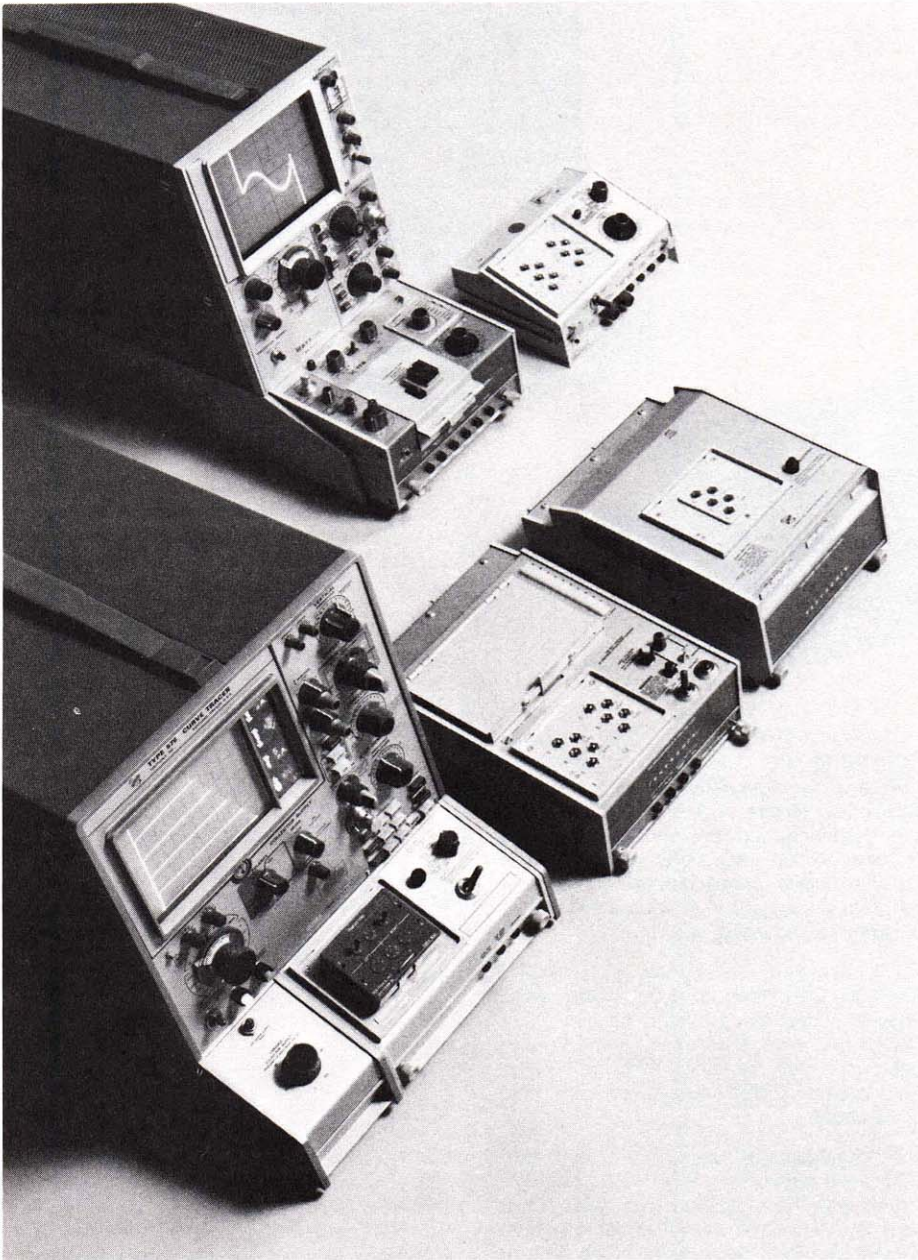

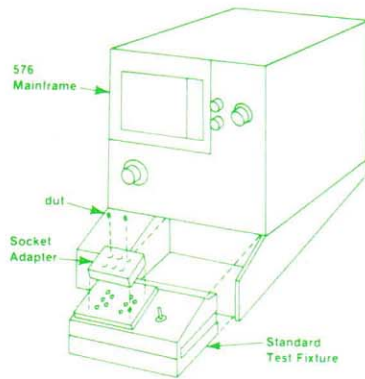

576

Tests Two- and Three- Terminal Discrete Semiconductors

Power Capability up to 220 W

Convenient Scale Factor Readout

Other Test Fixtures for Testing Power Devices and Semi-Automated Testing

The TEKTRONIX 576 Curve Tracer System continues to hold the title "standard of the industry." The 576 accepts three different test fixtures: the Standard Test Fixture, 172 Programmable Test Fixture (described on p 304), and the 176 Pulsed High-Current Fixture (described on p 305). The 576 is an excellent general purpose curve tracer system that performs well in applications where high current testing is required.

With the Standard Test Fixture, the collector supply of the 576 delivers up to 220 watts peak to the device under test. The step generator can deliver up to 2 A in both its current and voltage modes of operation. Of course, with the 176, the 576 is capable of pulsed collector operation up to 200 amps peak.

One of the features that sets the 576 apart from the 577 is the display area READ-OUT. Adjacent to the 576's CRT are alphanumeric indicators of vertical and horizontal deflection factors, step amplitude, and Beta/div or g_m /div. The Beta or g_m readout saves the operator from the arithmetic usually necessary to arrive at these parameters. The READ-OUT also provides a permanent record of major knob settings in 576 CRT photographs.

Another unique feature of the 576 is the Calibrated Display Offset. Combining a calibrated position control and a display magnifier, the Display Offset increases resolution and allows the operator to make more precise measurements.

Other features of the 576 Curve Tracer are: adjustable current limiting in the step generator, either 300 μ s or 80 μ s pulse width in pulsed base operation, pushbuttons to check display zero and calibration, and illuminated graticule.

CHARACTERISTICS

COLLECTOR SUPPLY

Modes — NORM: positive or negative full wave rectified ac (line frequency); dc: positive or negative dc; LEAKAGE: emitter current rather than collector current measurements with an increase in the basic vertical deflection factor to 1 nA/div.

Voltages — Peak open circuit voltages within +35% and -5% of indicated range.

| Range | 15 V | 75 V | 350 V | 1500 V |
|-----------------------------|-------|------|-------|--------|
| Max Continuous Peak Current | 10 A | 2 A | 0.5 A | 0.1 A |
| Peak Pulse Mode Current | ≥20 A | ≥4 A | ≥1 A | ≥0.2 A |

Series resistance is from 0.3 Ω to 6.5 MΩ in 12 steps, all within 5% or 0.1 Ω. Peak power limit setting: 0.1 W, 0.5 W, 2.2 W, 10 W, 50 W, 220 W.

Safety Interlock — Protects operator from 75 V, 350 V, and 1500 V collector voltages.

STEP GENERATOR

Current Mode — Step/offset amplitude range is 5 nA/mV/step (with X0.1 MULT) to 2 V/step, 1-2-5 sequence. Max current (steps and aiding offset) is X20 AMPLITUDE setting, except X10 (2 A) at 200 mA/step and X15 (1.5 A) at 100 mA/step. Max voltage (steps and aiding offset) is at least 10 V. Max opposing offset current is X10 AMPLITUDE switch setting or 10 mA, whichever is less. Max opposing voltage is limited at 1 V to 3 V.

Voltage Mode — Step/offset amplitude range is 5 mV/step (with X0.1 MULT) to 2 V/step, 1-2-5 sequence. Max voltage (steps and aiding offset) is X20 AMPLITUDE switch setting, 40 V max. Max current (steps and aiding offset) is at least 2 A at 10 V, derating linearly to 10 mA at 40 V. Short circuit current limiting is 20 mA, 100 mA, 500 mA +100%, -0%; 2 A +50%, -0%. Max opposing offset voltage; X10 AMPLITUDE switch setting. Max opposing current; limited at 5 mA to 20 mA.

Accuracy — Incremental; within 5%, between steps, within 10% with X1.0 MULT. Absolute; within 2% of total output including offset, or 1% of AMPLITUDE setting, whichever is greater. Offset multiplier; 0 to X10 the AMPLITUDE setting, continuously variable. Polarity AID(s) or OPPOSE(s) the step polarity.

Step Rates — X0.5, X1 (NORM), and X2 the collector supply rate. The collector supply rate is twice line frequency.

Pulsed Steps — ≈80 μs or 300 μs width, at NORM or X0.5 rates.

Step/Offset Polarity — The STEP GEN polarity is the same as the COLLECTOR SUPPLY polarity, and positive in the ac position. Step polarity may be inverted by actuating the INVERT pushbutton.

Step Family — REPETITIVE or SINGLE FAMILY (manually actuated).

Number of Steps — Digitally selectable between 1 and 10.

DEFLECTION CONTROLS

Display Accuracies — As a percentage of highest on-screen value.

| NORM and DC MODES | NORM | OFFSET and MAGNIFIED with CENTERLINE VALUE from: | | |
|---|-------------------------|--|-----------|-----------|
| | | 100-40 div | 35-15 div | 10-0 div |
| Vert Collector Current | 3% | 2% | 3% | 4% |
| Horiz Collector Volts | 3% | 2% | 3% | 4% |
| Horiz Base Volts | 3% | 2% | 3% | 4% |
| LEAKAGE MODE | | | | |
| Vert Emitter Current/div: | | | | |
| 10 nA-2 mA/div | 3% ± 1 nA | | | |
| 1 nA-200 μA/div (magnified) | | 2% ± 1 nA | 3% ± 1 nA | 4% ± 1 nA |
| 5, 2, 1 nA/div | 5% ± 1 nA | | | |
| Horiz Collector or Base Volts with Emitter Current/div of: | | | | |
| ≥1 μA | 3% | 2% | 3% | 4% |
| 100, 10, or 1 nA | 3% plus 25 mV/vert div | NOT APPLICABLE | | |
| 200, 20, or 2 nA | 3% plus 50 mV/vert div | NOT APPLICABLE | | |
| 500, 50, or 5 nA | 3% plus 125 mV/vert div | NOT APPLICABLE | | |
| VERT STEP GEN POSITION | 4% | 3% | 4% | 5% |
| HORIZ STEP GEN POSITION | 4% | 3% | 4% | 5% |

Vertical Deflection Factor — Collector current is 1 μA/div to 2 A/div, 20 steps in 1-2-5 sequence (0.1 μA/div with X10 magnification). Emitter current is 1 nA/div to 2 mA/div, 20 steps in 1-2-5 sequence. Step generator is 1 step/div.

Horizontal Deflection Factor — Collector volts; 50 mV/div to 200 V/div 12 steps (5 mV/div with X10 magnification). Base volts; 50 mV/div to 2 V/div, 6 steps (5 mV/div with X10 magnification). Step generator; 1 step/div.

Displayed Noise — 1% or less or:

| RANGE | 15 V | 75 V | 350 V | 1500 V |
|----------------------|------|------|-------|--------|
| Vertical—Collector | 1 μA | 1 μA | 2 μA | 5 μA |
| Vertical—Emitter | 1 nA | 1 nA | 2 nA | 5 nA |
| Horizontal—Base | 5 mV | 5 mV | 5 mV | 5 mV |
| Horizontal—Collector | 5 mV | 5 mV | 20 mV | 200 mV |

Calibrator (CAL) — Dc voltage (accurate within 1.5%) provided to check and adjust vertical and horizontal gain.

Position Controls — Fixed 5 div increments within 0.1 div. Continuous fine control over 5 div or less.

Display Offset — 21 calibrated positioning increments, vertically or horizontally, of 0.5 div or 5 div with X10 MAGNIFIER.

CRT and READOUT

CRT — 6.5 in rectangular with parallax-free, illuminated graticule in centimeters. The calibrated area is 10 cm vertical by 10 cm horizontal (12 cm usable horizontal). P31 Phosphor normally supplied.

Readout — The readouts, adjacent to CRT, are digital indicators of the following parameters: PER VERT DIV from 1 nA/div to 2 A/div; PER HORIZ DIV from 5 mV/div to 200 V/div; PER STEP from 5 nA/step to 2 A/step, 5 mA/step to 2 V/step; β (BETA) or g_m, PER DIV from 1 μ to 500 k calculated from CURRENT/DIV, X10 MAG, STEP AMPLITUDE, and X0.1 MULT.

STANDARD TEST FIXTURE

Description — A plug-in fixture with two sets of 5 pin test terminals, the EMITTER GROUNDED or BASE GROUNDED switch, LEFT-OFF-RIGHT switch, STEP GEN OUTPUT EXT BASE or EMITTER input and the OPERATOR PROTECTION BOX. The test terminals accept either the 6 pin universal adapters, 3 pin adapters, or the high-power transistor adapters with KELVIN contacts.

OTHER CHARACTERISTICS

Power Requirements — Power source; operates only with an unbalanced-to-ground power source. For safe operation, the power line neutral (white or "identified" conductor) must be connected to the instrument neutral (unfused), and the power plug safety ground (green conductor) must return to ground through a different path than the power line neutral. Voltage Ranges; the quick-change line-voltage range selector accommodates 90 V ac to 136 V ac or 180 V ac to 272 V ac (six positions), at 48 Hz to 66 Hz line frequency. Max power consumption is 305 W, stand by power is ≈60 W.

Ambient Temperature — Performance characteristics are valid over an ambient temperature range of +10°C to +40°C.

PHYSICAL CHARACTERISTICS

| Dimensions | cm | in |
|----------------|-----------|-----------|
| Height | 38.1 | 15.0 |
| Width | 29.2 | 11.5 |
| Depth | 58.4 | 23.0 |
| Weights | kg | lb |
| Net | 32.0 | 70.5 |
| Shipping | ≈48.5 | ≈107 |

INCLUDED ACCESSORIES

Transistor adapter (013-0098-02), FET adapter (013-0099-02), TO3 adapter (013-0100-01), TO66 adapter (013-0101-00), axial lead diode adapter (013-0111-00), stud diode adapter (013-0110-00), Kelvin sensors for large and small plastic transistors (013-0138-01), and protective cover (337-1194-00).

ORDERING INFORMATION

576 Curve Tracer with Standard Test Fixture \$8775

The 576 Option 01 deletes the parameter readout module but maintains provisions for insertion of the module (020-0031-00) at any time.

Option 01 Sub \$650

Auto Scale-Factor Readout Module

020-0031-00 \$1500

INTERNATIONAL POWER CORD AND PLUG OPTIONS

Option A1 Universal Euro 220 V/16A No Charge

Option A2 UK 240 V/13A No Charge

Option A3 Australian 240 V/10A No Charge

Option A4 North American 240 V/15A No Charge

OPTIONAL ACCESSORIES

Camera — See Oscilloscope/Camera Adapter chart in Camera section of this catalog.

Test Set-up Chart — Package of 250.

Order 070-0970-01 \$10

172 Test Fixture See page 304

176 Test Fixture See page 305

Socket Adapters See pages 310 & 311

172

Semi-Automated Test Fixture

Tests up to 11 Parameters

Reduces Total Test Time

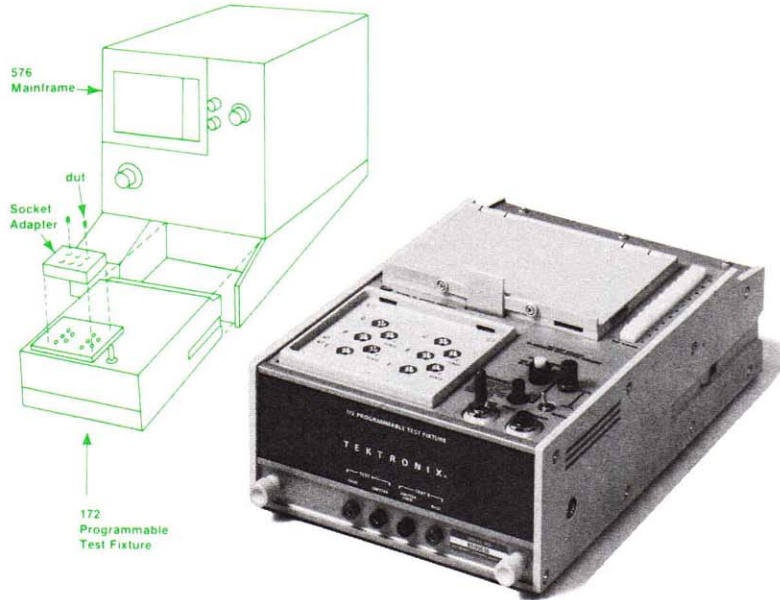

The 172 Programmable Test Fixture, when used with the TEKTRONIX 576 Curve Tracer, permits the operator to program a sequence of tests of J FETs, transistors, and diodes.

The 172 can greatly reduce total test time in applications when more than one measurement is made on a batch of many devices. Without the 172 all devices in the batch must be repeatedly inserted in the test fixture, once for every measurement. However, the 172 Programmable Test Fixture performs as many as eleven different tests on each device.

The 172 sequences through the various tests either automatically or manually. A variable RATE control is provided to set the test sequence at a

rate which is best for the operator. New operators require more time per test, but with experience they will want to test at a faster rate. A front-panel switch or an optional foot switch advances the test in the manual mode.

CHARACTERISTICS

VERTICAL AND HORIZONTAL AMPLIFIERS

Display Accuracies — The same as the 576 Curve Tracer with its included Standard Test Fixture.

Vertical Deflection Factor — Tests 1 and 2 (Collector or Emitter Current): 1 μ A to 2 A/div in 20 steps. Tests 3, 4, and 8, 9, 10, 11 (Collector or Breakdown Current): 1 μ A to 0.5 A/div in 18 steps. Tests 5, 6, 7 (Leakage Current): 1 nA to 0.5 A/div in 27 steps. All steps are in a 1-2-5 sequence.

Horizontal Deflection Factor — Test 1: 0.05 V/div to 200 V/div in 12 steps. Test 2 (Base Voltage): 100 mV/div to 2 V/div in 5 steps. Input Z for Test 2, at least 100 MHz at 100 mV/div and 200 mV/div. 1 M Ω (within 2%) at 0.5 V/div, 1 V/div, and 2 V/div. Tests 3 and 4 (Collector Voltage): 100 mV/div to 2 V/div in 5 steps. Tests 5 through 11 (Breakdown or Leakage Voltage): 100 mV/div to 50 V/div in 9 steps. All steps are in a 1-2-5 sequence.

Collector Sweep Voltage — At least 2 V open circuit, or 1.5 A short circuit, at 100 mV/div and 200 mV/div. At least 5 V open circuit, or 2 A short circuit, at 500 mV/div. At least 20 V open circuit, or 150 mA short circuit, at 1 V/div and 2 V/div.

Current Supply Accuracy — 0.1 μ A to 11 mA, accurate within 2% \pm 30 nA with up to 500 V compliance. 10 mA to 110 mA, accurate within 2% \pm 30 nA with up to 50 V compliance. Increments of current are: 0.1 μ A (from 0.1 μ A to 11 μ A), 1 μ A (from 10 μ A to 110 μ A), 10 μ A (from 100 μ A to 1.1 mA), 100 μ A (from 1 mA to 11 mA) and 1 mA (from 10 mA to 110 mA).

Voltage Supply Accuracy — 1 V to 500 V, accurate within 3% \pm 300 mV with at least 0.5 mA compliance.

Test Display Time Range (Automatic) — 300 ms or less to at least 2 s continuously variable. Manual operation from a front-panel switch or optional foot switch.

OTHER CHARACTERISTICS

Ambient Temperature — Performance characteristics are valid over an ambient temperature range of +10°C to +40°C.

PHYSICAL CHARACTERISTICS

| Dimensions | cm | in |
|----------------|------|-------|
| Height w/cover | 16.5 | 6.5 |
| Width | 19.8 | 7.8 |
| Depth | 31.5 | 12.4 |
| Weights | kg | lb |
| Net | 5.2 | 11.5 |
| Shipping | ≈8.2 | ≈18.0 |

Included Accessories — One protective cover, five programming cards, 250 programming card pins, five CRT overlay limit cards.

Order 172 Programmable Test Fixture \$3665

| TESTS THAT CAN BE PERFORMED ON: | | | | PROGRAMMABLE CAPABILITIES |
|---------------------------------|---|--|----------------|---|
| Test | Xstr | J FETs | Diodes | |
| *1 | H _{FE} , V _{CE(sat)} | V _P | V _F | PEAK CURRENT up to 10 A PEAK VOLTS up to 350 V. |
| 2 | V _{BE} | | | Horiz range is 100 mV/div to 2 V/div (other conditions same as Test 1). |
| 3 | H _{FE} , V _{CE(sat)} | I _{DSS} , R _{DS(on)} | | Base Drive: 100 nA to 110 mA. When testing J FETs the base terminal is shorted to the emitter terminal. Collector Sweep: three fixed ranges; 2 V, 5 V, and 20 V peak. Short circuit currents on these ranges are 1.5 A, 2 A, and 150 mA, respectively. |
| 4 | Same as #3. | | | |
| 5 | I _{CEO} or I _{CES} , I _{CER} with external short or resistor | | | Voltage Supply: 1 V to 500 V dc. Leakage current measurements to 0.5 mA. The most sensitive deflection factor is 1 nA/div. |
| 6 | I _{CBO} | I _{GSS} | | Same as #5. |
| 7 | I _{EBO} | | I _R | Same as #5. |
| 8 | V _{(BR)CEO} or V _{(BR)CER} with external resistor | | V _F | Current Supply: 100 nA to 11mA dc for breakdown voltage measurements to 500 V. Up to 100 mA dc for breakdown voltage measurements to 50 V. |
| 9 | V _{(BR)CES} | | | Same as #8. |
| 10 | V _{(BR)CBO} | BV _{GSS} | | Same as #8. |
| 11 | V _{(BR)EBO} | | V _R | Same as #8. |

*All of the test conditions for Test 1 are controlled by the 576 front-panel controls. Test 2 has the same conditions as for Test 1 except the horizontal amplifier is connected to the emitter-base terminals, and the horizontal deflection factor is controlled by the programming card.

For the remaining tests the only 576 controls that are functional are the Polarity and CRT controls such as INTENSITY, FOCUS, DISPLAY OFFSET.

176

Tests Power Transistors

Tests up to 200 Amps in Pulsed Mode

1000 Watt Capability

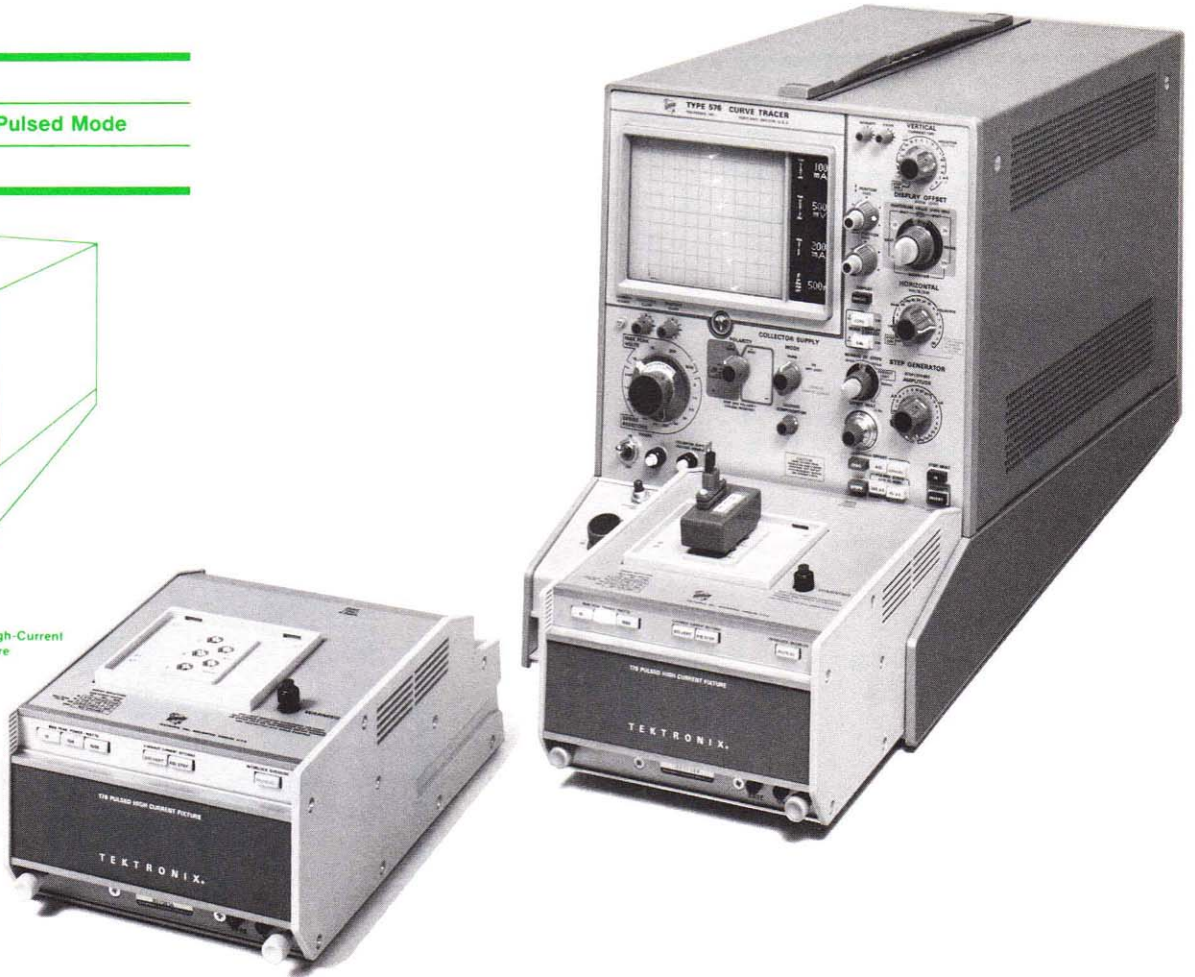
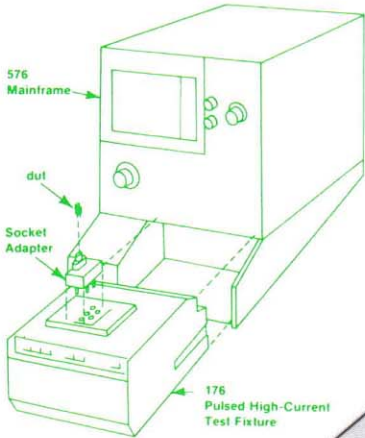

The 176 Pulsed High-Current Fixture provides the 576 Curve Tracer with pulsed collector operation to 200 amps peak and pulsed base steps to 20 amps peak. The step offset, when selected, is also pulsed. The pulsed operating mode allows many tests previously considered impossible. For example, small signal transistors can be tested under pulsed collector breakdown conditions without overdissipation. The 176 Test Fixture fits in place of the 576 Standard Test Fixture. The collector pulse is slaved to the 576 in regard to width and repetition rate.

The pulse width is selected by depressing the 300 μ s or 80 μ s pushbutton on the 576 Mainframe (usually, 300 μ s should be selected). The rep rate is automatically set when the 176 is inserted in the mainframe. Rep rate is also dependent on power-line frequency. The five highest VERTICAL CURRENT/DIV (0.1 A/div to 2 A/div) of the 576 can be multiplied X10 by actuation of the X10 VERT pushbutton on the 176. This feature enables viewing of up to a 200 amp peak display. The five highest STEP GENERATOR AMPLITUDE base current steps of the 576 (10 mA to 200 mA) can be multiplied X10 by actuation of the X10 STEP pushbutton on the 176. This feature enables the pulsed base step generator on the 176 to provide up to a 20 amp base step (tenth step). Both X10 VERT and X10 STEP pushbuttons provide inputs to the fiberoptic readout to display actual values.

CHARACTERISTICS

COLLECTOR SUPPLY (PULSED)

- Width** — 300 μ s or 80 μ s determined by 576.
- Repetition Rate** — Power-line frequency.
- Polarity** — + or - determined by 576 polarity control.
- Amplitude** — Ranges are 15, 75, 350 V nominal, controlled by MAX PEAK VOLTS switch on 576. Current (minimum available at low line into shorted load) is 15 V range, 200 A; 75 V range, 40 A; 350 V range, 8 A.
- Max Peak Watts** — Three illuminated pushbuttons select 10, 100, 1000 W max peak power.

STEP GENERATOR

- Current Ranges (X10 STEP selected)** — Step-Offset Amplitude Range is 100 mA to 2 A, 5 steps in a 1-2-5 sequence. Max Current (Steps and Aiding Offset) is X200 576 AMPLITUDE setting or 20 A, whichever is less. Max Voltage (Steps and Aiding Offset) is at least 5 V up to 10 A and 2 V up to 20 A.
- 576 Offset Multiplier** — 0 to X100 576 AMPLITUDE switch setting.
- Step Rate** — Power-line frequency.
- Pulsed Steps** — 300 μ s or 80 μ s wide.
- Step/Offset Polarity** — The STEP GEN polarity is the same as the COLLECTOR SUPPLY polarity. Step polarity may be inverted by actuating the INVERT pushbutton.
- Accuracy (Current steps including offset)** — Incremental is within 5% between any two steps; within 10% with X0.1 STEP MULT. Absolute is within 3% of total output \pm 1% of one step or within 3% of one step, whichever is greater.

VERTICAL AMPLIFIER

- Deflection Factor (X10 VERT selected)** — 1 A/div to 20 A/div, 5 steps in a 1-2-5 sequence.

OTHER CHARACTERISTICS

Ambient Temperature — Performance characteristics are valid over a temperature range of 0°C to +40°C.

PHYSICAL CHARACTERISTICS

| Dimensions | cm | in |
|----------------|-----------|-----------|
| Height | 11.7 | 4.6 |
| Width | 20.1 | 7.9 |
| Depth | 29.0 | 11.4 |
| Weights | kg | lb |
| Net | 5.8 | 12.8 |
| Shipping | 8.2 | 18.0 |

Included Accessories — T036 adapter (013-0112-00); stud diode adapter (013-0110-00); protective shield (337-1194-00).

Order 176 Pulsed High-Current Fixture \$4145

577

Test Two- and Three- Terminal
Discrete Semiconductors

Storage Capability

Power Capability up to 100 Watts

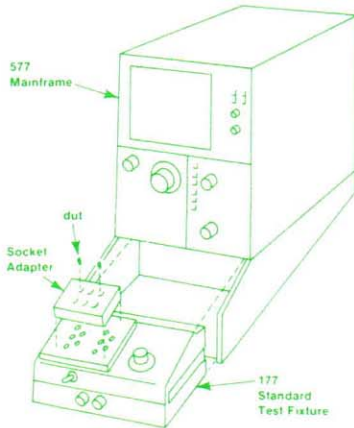

The 577 Curve Tracer System, when used with the 177 Standard Test Fixture, is a smaller and lighter configuration that retains many of the important features and performance of the 576. The 577 also accepts the 178 Linear IC Test Fixture. The major features that separate the 577 from the 576 are storage and the emphasis on low current measurements.

The 577's storage CRT may be used to overlay the characteristic curves of one device on top of the stored characteristics of another. Dot displays (generated during high current pulsed testing or during very low current testing under dc conditions) can be transformed into complete characteristic curves by simply moving them across the CRT while in the storage mode. A good example of a dot display occurs in op amp testing because the open-loop 3 dB bandwidth of many op amps is so low that the curves must be plotted slowly. Linear ICs such as op amps may be tested with the 577 by using the 178 Linear IC Test Fixture (see page 308).

In the 577/177 Curve Tracer System several features facilitate low current measurements. They include: small current sensing resistors (which result in less capacitive looping), current sensing that always takes place in the collector supply lead (which permits measurements on three-terminal active devices at the lowest current ranges and eliminates the need for a correction to the horizontal deflection factor), and a display filter (which reduces vertical deflection noise).

Although the 577/177 Collector Supply has lower power capability (the 576 can deliver approximately 2.2 times as much power to the device under test), approximately the same test current is available, 10 A continuous peaks at line frequency. The 577/177 provides its highest currents at a lower voltage than does the 576.

Other innovations in the 577/177 Curve Tracer are an emitter-base breakdown position on the lead selector switch, availability of approximately 95 steps from the step generator, an uncalibrated bias supply, independent magnifiers that increase resolution on either or both CRT axes, and a beam finder.

CHARACTERISTICS

All characteristics are for the 577 Curve Tracer Mainframe operating with a 177 Standard Test Fixture.

COLLECTOR SUPPLY

Modes — Five modes of collector supply operation are selectable. These are: ac at line frequency, positive full wave rectified, negative full wave rectified, positive dc, or negative dc.

Voltage — The voltage is variable to the max peak volts selected.

| Max Peak Volts Open Circuit | 6.5 V | 25 V | 100 V | 400 V | 1600 V |
|-----------------------------|-------|-------|--------|--------|--------|
| Continuous Current, Peak | 10 A | 2.5 A | 0.6 A | 0.15 A | 0.04 A |
| Peak Pulse Current | 20 A | 5 A | 1.25 A | 0.30 A | 0.08 A |

Series Resistance — 14 values from 0.12 Ω to 8 M Ω . Coupling of series resistance and voltage controls maintains max peak power to the device under test when changing voltage ranges.

Safety Interlock — Protects operator from 100, 400, and 1600 volt ranges. Momentary button provides for overriding interlock.

STEP GENERATOR

Current Mode — Step amplitude range is 5 nA/step (with STEP X0.1) to 200 mA/step, in a 1-2-5 sequence. Available current is at least 2 A on the highest amplitude setting with 5 V or more compliance. For opposing offset, available current is at least 10 mA with voltage limited between 1 V and 5 V.

Voltage Mode — Step amplitude range is 5 mV/step (with STEP X0.1) to 2 V/step, in a 1-2-5 sequence. Current is limited between 100 mA and 200 mA. For opposing offset, available current is at least 10 mA (at 0 V) derating to 0 mA at 20 V.

Accuracy — Incremental: within 2% between steps. Absolute: within 3% of total output or AMPLITUDE setting, whichever is greater. When STEP X0.1 is actuated the absolute step accuracy is 4%.

Step Rate — Selectable at X1 (SLOW), X2 (NORM), or X4 (FAST) line frequency.

Pulsed Steps — Steps can be gated for a duration of $\approx 300 \mu s$ for testing at low duty cycle.

Step/Offset Polarity — With NORM POLARITY selected, the Step Generator polarity is the same as the Collector Supply polarity, and positive in the ac position. Polarity can be independently inverted with STEP/OFFSET POLARITY control or from the test fixture.

Offset — The amplitude of the entire set of steps can be offset in a continuously variable and calibrated manner to either AID or OPPOSE steps. Max range of offset is 10 full-amplitude steps.

Step Family — Repetitive or single family.

Number of Steps — Selectable from 1 to 10 full-amplitude steps. Selectable up to ≈ 95 steps when using STEP X0.1 multiplier.

DEFLECTION CONTROLS

Display Accuracies — As a percentage of highest on-screen value.

| Display Mode | Normal | Magnified |
|------------------------|---------------|---------------|
| Vert Collector Current | 3% ± 1 nA | 4% ± 1 nA |
| Horiz Collector Volts | 3% | 4% |
| Horiz Base Volts | 3% | 4% |
| Horiz Step Gen | 4% | 5% |

Vertical Deflection Factor — Collector current is 2 nA/div to 2 A/div, 28 steps in 1-2-5 sequence (0.2 nA/div to 0.2 A/div with X10 magnification).

Horizontal Deflection Factor — Collector volts; 50 mV/div to 200 V/div, 12 steps in a 1-2-5 sequence (5 mV/div to 20 V/div with X10 magnification). Base volts; 50 mV/div to 2 V/div, 6 steps in a 1-2-5 sequence (5 mV/div to 0.2 V/div with X10 magnification). Step generator; 1 step/div (0.1 step/div with X10 magnification).

Automatic Scale Factor Readout — Change in deflection factor is indicated by lights behind the knob skirt when using X10 MAG.

Automatic Positioning — Trace (or spot) is automatically positioned when Collector Supply polarity is changed when using the 177.

Display Invert — Single control inverts display and repositions trace.

Display Filter — Selectable low pass filter reduces vertical noise for easier high sensitivity measurements.

CRT

CRT — Rectangular 6.5 in with an 8 x 10 div (1.27 cm/div) parallax-free internal graticule. Two display modules are available for the 577. The D1 display unit has a split-screen storage CRT with phosphor similar to P1. The D2 display unit has a nonstorage CRT with P31 Phosphor. Accelerating potential is 3.5 kV.

Beam Finder — Compresses off-screen trace to within graticule area.

Ambient Temperature — Performance characteristics are valid over an ambient temperature of +10°C to +40°C.

PHYSICAL CHARACTERISTICS

| Dimensions | 577/D1 or 577/D2 | | 177 | |
|------------|------------------|------|------|-----|
| | cm | in | cm | in |
| Height | 50.3 | 19.8 | 10.2 | 4.0 |
| Width | 22.4 | 8.8 | 20.1 | 7.9 |
| Depth | 58.4 | 23.0 | 15.2 | 6.0 |
| Weights | kg | lb | kg | lb |
| Net | 18.1 | 40 | 1.1 | 2.5 |
| Shipping | 22.7 | 50 | 2.7 | 6 |

Note: When the 577 and 177 are ordered together their combined shipping weight is: domestic ≈ 53 lb or ≈ 24 kg.



177 TEST FIXTURE

Device Lead Selection — Switch provides six different lead configurations. Three positions for EMITTER GROUNDED measurements provide STEP GEN, OPEN (OR EXT), and SHORT base terminal connections. Two positions for BASE GROUNDED measurements provide STEP GEN and OPEN (OR EXT) emitter terminal connections. One position provides for EMITTER BASE BREAKDOWN or leakage measurements up to 25 volts.

Left-Right Switch — Selects left or right test connections. Off in center position. Test connection area accepts all TEKTRONIX Curve Tracer adapters and protective cover. Kelvin connections are provided for emitter and collector terminals.

Looping Compensation — Reduces display loops due to test adapter capacitance and some device capacitance.

Variable Voltage Supply — Continuously variable bias supply from -12 V to +12 V. Source resistance is 10 k Ω or less.

OTHER CHARACTERISTICS

Power Requirements — 100, 110, 120 V ac or 200, 220, 240 V ac, all within $\pm 10\%$. 50 to 60 Hz, 155 W max at 110 V ac and 60 Hz.

INCLUDED ACCESSORIES

Transistor adapter for most bipolar transistors and some MOS FETs (013-0098-02) axial lead diode adapter with Kelvin sensing terminals (013-0111-00), protective shield for test connection area (337-1194-00).

ORDERING INFORMATION

| | |
|--|-----------------|
| 577/D1 Storage Curve Tracer Mainframe | \$4850 |
| 577/D2 Nonstorage Curve Tracer Mainframe | \$4195 |
| Option 10, 10 x 10 cm Graticule ; available with either storage or nonstorage mainframe | Add \$65 |
| 177 Standard Test Fixture | \$1000 |

OPTIONAL ACCESSORIES

| | |
|--|---------------|
| 178 Linear Test Fixture ; see following page for complete description | \$2500 |
| Camera — C-5C, see page 322 for complete description | \$500 |
| Cart — Tek Lab Cart, Model 3 (see page 345) | \$425 |
| Order Model 3 | \$425 |
| Test Set-up Chart — Package of 250 | \$7.50 |
| Order 070-1639-00 | \$7.50 |
| Device Adapter Sockets ; see page 310 for complete description. | |

178

Tests Single, Dual, or Quad:
Operational Amplifiers, Comparators
Differential Amplifiers, Regulators and more



Since linear ICs are typically tested under very low current conditions, the 577/178 Curve Tracer System is ideally suited to the task. The 178 Linear IC Test Fixture provides the necessary accurate low current measurement capability, test cards set up the measurement function, and the 577's storage CRT allows the operator to transform the dot display (usually seen under low current dc conditions) into a complete characteristic curve by slowly sweeping the dot across the CRT while in the Storage Mode.

A 577/178 Curve Tracer System is composed of a 577 Mainframe, 178 Linear IC Test Fixture, appropriate test cards (choose from three op amp cards and two regulator cards), and the proper socket adapter (see page 310) that interfaces the system to the device under test.

Test cards, which slide into the 178, define the measurement function of the 178 Test Fixture. Two families of test cards are available: op amp cards and regulator cards. Op amp cards are used for testing standard and special op amps, comparators, differential amplifiers, video amplifiers, etc. Regulator cards are used for testing positive and negative three-terminal voltage regulators.

OP AMP CARDS

The **Standard Op Amp Card** is designed to test devices that require single or dual power supplies, have two (differential) high-impedance inputs, and a single output. Common measurements include: offset voltage, positive and negative input current, cmrr, gain, positive and negative psrr, positive and negative supply current, and collector supply current.

The **Hardwire Card** is designed for those applications where there is an advantage in preparing individual cards for specific devices so that they may be quickly switched to accommodate a change in the type of device under test. The Hardwire Card also offers a greater degree of freedom to the knowledgeable designer in testing special devices.

The **Multiple Op Amp Card** allows the operator to test up to four devices in a single package by simply operating a four-position switch. The four-position switch selects the op amp (in a multiple op amp package) or the selection of a linear IC to be tested. The measurements performed are the same as those available with the Standard Op Amp Card.

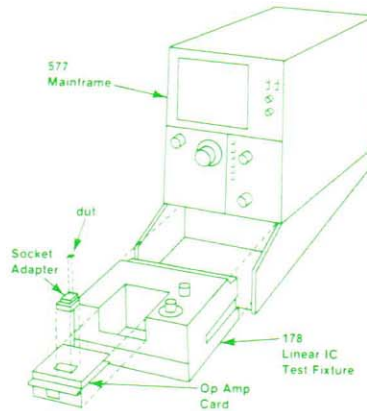

Socket Adapters for Op Amp Cards — The device under test socket on the Standard and Multiple Op Amp Cards accepts several types of socket adapters using the Amphenol-Barnes adapter system. This system accepts most of the standard package configurations (TO5, DIP, flat pack, etc). Sockets for these cards are shown on page 310.

REGULATOR CARDS

There are two types of Regulator Cards, positive and negative. These cards are used primarily in measuring parameters of three-terminal voltage regulators. Parameters measured include: output voltage, load regulation, line regulation and ripple regulation, and quiescent and common terminal current.

Socket Adapters for Regulator Cards — Socket adapters for both positive and negative three-terminal regulators are the same as the Kelvin Sensing Adapters used on the standard curve tracer (see page 310).

CHARACTERISTICS

| VERTICAL DEFLECTION (1-2-5 Sequence) | NORMAL | MAGNIFIED |
|--|--|---|
| Input Voltage or Δ Input Voltage Accuracy | 10 μ V/div to 50 mV/div 3% | 1 μ V/div to 5 mV/div 4% |
| Input Current Accuracy | 50 pA/div to 0.2 mA/div 3% \pm 50 pA | 5 pA/div to 20 μ A/div 4% \pm 50 pA |
| Power Supply Current Accuracy | 0.1 μ A/div to 50 mA/div 3% \pm 0.1 μ A | 10 nA/div to 5 mA/div 4% \pm 0.1 μ A |
| Collector Supply Current Accuracy | 1 nA/div to 50 mA/div 3% \pm 1 nA | 0.1 nA/div to 5 mA/div 4% \pm 1 nA |

Accuracies are a percentage of highest on-screen values.

Power Supplies — Positive and negative supplies are adjustable from 0 to 30 V, available current is at least 150 mA with adjustable current limiting. The voltage of both supplies can be adjusted from a single calibrated control; accuracy is within 2% \pm 100 mV. Negative supply can be independently adjusted by an uncalibrated control.

Sweep Generator — A sinusoidal signal controls the output, common-mode input, or the power supply voltages of the device under test. The frequency is adjustable from 0.01 Hz to 1 kHz; amplitude is adjustable up to 30 V peak.

Source Resistance — For input resistor pairs, selectable 50 Ω , 10 k Ω , 20 k Ω , and 50 k Ω , or external resistors may be used. When the vertical deflection factor is in one of the less sensitive positions, 1 mV through 50 mV/div, the input resistance values are 550 Ω greater.

Load Resistance — Six selectable load resistors, 100 Ω , 1 k Ω , 2 k Ω , 5 k Ω , 10 k Ω , 20 k Ω , and 50 k Ω , or external resistors may be used.

Collector Supply — The 25 V and 100 V ranges of the Collector Supply (located on 577 Mainframe) are available to the 178 Test Fixture. Supply output is located on the 178 front-end panel and on the device card. Automatic positioning with supply polarity is inoperative when using the 178 Test Fixture. (See 577/177 characteristics for Collector Supply performance.)

Step Generator — All the capabilities of the Step Generator (located on 577 Mainframe) are available to the 178 Test Fixture. Generator output is located on the 178 front-end panel and on the device card. (See 577/177 characteristics for Step Generator performance.)

DUT Supplies Disconnect — A single switch disconnects all power to the device under test: both plus and minus Power Supplies, Collector Supply, and Step Generator.

Function Switch — Selects vertical and horizontal deflection signals and connection of the test signal to the device under test.

Zero — Single pushbutton provides a zero reference to the CRT display and in certain functions, nulls out offset voltage in order to measure Δ input V on the vertical display axis.

THREE-TERMINAL REGULATOR TEST CARD CHARACTERISTICS

Device Under Test Input Supply

Input Voltage — Two ranges 0-30 V and 0-60 V. 0-30 V is within \pm 2% \pm 200 mV of dial setting, and 0-60 is within \pm 2.5% \pm 300 mV of dial setting.

Regulation — Within 200 mV.

Input Sweep Frequency — Dc to 1 kHz.

300 μ s Pulsed Current — 5 mA to 2 A.

Short Duration DC Current (One minute)

| Supply Voltage | Current |
|----------------|---------|
| 0 - 10 | 700 mA |
| 10 - 20 | 350 mA |
| 20 - 40 | 300 mA |
| 40 - 60 | 120 mA |

Device Under Test Current Load — 5 mA to 2 A within \pm 3% of 0 to 1.25 mA.

Device Under Test Comparison Output Dc Voltage Accuracy — 0-10 V range within \pm 1% \pm 20 mV; 0-100 V range within \pm 1% \pm 150 mV.

PHYSICAL CHARACTERISTICS

| Dimensions | cm | in |
|------------|------|-----|
| Height | 11.4 | 4.5 |
| Width | 20.1 | 7.9 |
| Depth | 19.8 | 7.8 |
| Weights | kg | lb |
| Net | 1.5 | 3.3 |
| Shipping | 3.6 | 8.0 |

Included Accessories — Dual-in-line 16 pin IC socket (136-0442-00). Standard Op Amp Card with cover and ten patch cords (013-0149-01), interchangeable nomenclature panel for function switch (333-1770-00).

ORDERING INFORMATION

178 Linear IC Test Fixture \$2500

Standard Op Amp Card — (One included with 178)
013-0149-01 \$275

Hardwire Card
013-0150-01 \$125

Multiple Op Amp Card (013-0155-00) \$450

Positive Regulator Card
013-0147-00 \$695

Negative Regulator Card
013-0148-00 \$695

Standard Op Amp Card Positive Regulator Card

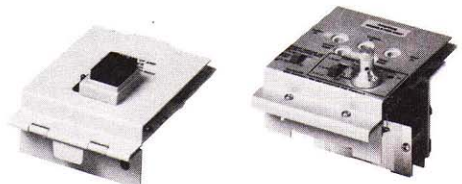

5CT1N and 7CT1N

Tests Semiconductor Devices to 0.5 W

10 nA/div to 20 mA/div Vertical Deflection Factors

0.5 V/div to 20 V/div Horizontal Deflection Factors

Easy to Operate

5CT1N



Curve Tracer

7CT1N



Curve Tracer



A



B



C



D



E

3 PIN ADAPTERS

The following accessories may be used with any of the TEKTRONIX Curve Tracer products. They do not have Kelvin sensing contacts.

- A. TO5 or TO18 Transistor Adapter —**
Order (013-0128-00) \$22
- B. Blank Adapter —** For mounting special sockets.
Order (013-0073-00) \$18
- C. TO3 or TO66 Transistor Adapter —**
Order (013-0070-01) \$40
- D. Diode Test Adapter —** Holds axial-lead diodes.
Order (013-0073-00) \$55
- E. Diode Test Adapter —** Magnetically holds steel axial-lead diodes.
Order (013-0079-00) \$150

The 7CT1N Curve Tracer is a plug-in unit for use in TEKTRONIX 7000 Series Oscilloscope Systems and the 5CT1N Curve Tracer is a plug-in unit for use in TEKTRONIX 5000 Series Oscilloscope Systems. Both are for displaying characteristic curves of small-signal semiconductor devices to power levels up to 0.5 watts. The plug-ins operate in a vertical compartment of the respective mainframes. The 7CT1N also operates in the horizontal compartments of the 7000 Series Oscilloscope Systems.

CHARACTERISTICS

| | X1 | | X10 | |
|----------------------|-----------|----------|----------|-----------|
| | 0.5 | 2 | 5 | 20 |
| Horizontal Volts/Div | 0.5 | 2 | 5 | 20 |
| Voltage Range | 0 - 7.5 V | 0 - 30 V | 0 - 75 V | 0 - 300 V |
| Maximum Current | 240 mA | 60 mA | 24 mA | 6 mA |

Max Open Circuit Voltage — Within $\pm 20\%$. Max short circuit current, within 30%.

Series Resistance — Automatically selected with horizontal V/div switches. Peak power is 0.5 W or less depending upon control settings.

High Voltage Warning — When the horizontal V/div switch is in the X10 position, a flashing warning light appears on the front panel indicating that dangerous voltages may exist at the test terminals.

STEP GENERATOR

Transistor Mode — Step amplitude range is 1 $\mu\text{A}/\text{step}$ to 1 mA/step, 1-2-5 sequence. Max current (steps plus aiding offset) is X15 amplitude setting. Max voltage (steps plus aiding offset) is at least 13 V. Max opposing offset current is at least X5 amplitude setting.

FET Mode — Step amplitude range is 1 mV/step to 1 V/step, 1-2-5 sequence. Voltage amplitude (steps plus aiding offset) is X15 amplitude setting, 13 V max. Source impedance is 1 k Ω \pm 1%.

Accuracy — Incremental; within 3% between steps. Absolute; within $\pm(3\% + X0.3$ amplitude setting.)

Step Polarity — The step generator polarity is the same as the collector/drain supply in the transistor mode and opposing in the FET mode.

Number of Steps — Selectable in one-step increments between 0 and 10.

Offset — Selectable from 0 to 5 steps. Polarity aids or opposes the step polarity.

Vertical Deflection Factors — 10 nA/div to 20 $\mu\text{A}/\text{div}$ with the ± 1000 control activated. 10 $\mu\text{A}/\text{div}$ to 20 mA/div in the X1 mode.

Vertical Display Accuracy — Within 5% in the X1 mode. Within 5% ± 0.2 nA per displayed horizontal V when in the ± 1000 mode.

Horizontal Deflection Factors — Selectable: 0.5 V, 2 V, 5 V, or 20 V.

5CT1N Horizontal Display Accuracy — Within 5% plus the deflection factor accuracy of the plug-in being driven. The plug-in would be a vertical or horizontal amplifier (such as the TEKTRONIX 5000 Series Plug-ins) with a 50 mV/div deflection factor and an input R of at least 50 k Ω and would be used in the horizontal compartment of the 5000 Series Oscilloscope Mainframe.

7CT1N Horizontal Display Accuracy — Within 5% plus the deflection factor accuracy of the plug-in being driven. The plug-in would be a vertical or horizontal amplifier (such as the TEKTRONIX 7000 Series Plug-ins) with a 100 mV/div deflection factor and an input R of at least 50 k Ω and would be used in the horizontal compartment of the 7000 Series Oscilloscope Mainframe.

OTHER CHARACTERISTICS

Ambient Temperature — Performance characteristics are valid from 0°C to +50°C.

PHYSICAL CHARACTERISTICS

| | 5CT1N | | 7CT1N | |
|----------|-------|------|-------|------|
| | cm | in | cm | in |
| Length | 30.5 | 12.0 | 36.8 | 14.5 |
| Width | 6.6 | 2.6 | 7.1 | 2.8 |
| Height | 12.7 | 5.0 | 12.7 | 5.0 |
| Weight | kg | lb | kg | lb |
| Net | 0.8 | 1.8 | 1.1 | 2.5 |
| Shipping | 1.8 | 4.0 | 2.7 | 6.0 |

Included Accessories — Test Adapter (013-0128-00) with two sets of test terminals, one with TO5 basing and the other with TO18 basing.

ORDERING INFORMATION

| | |
|--------------------------|--------|
| 5CT1N Curve Tracer | \$785 |
| 7CT1N Curve Tracer | \$1305 |

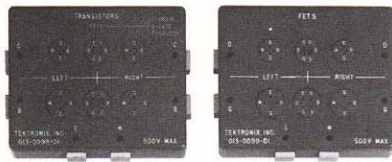

A

B



C

D

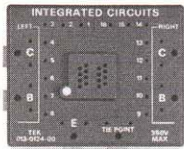

E



A



B



C



D



E



F



G



H

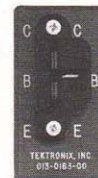

I



A



B



C



D

DUAL WIDTH ADAPTERS

The following accessories fit the side-by-side terminals on test fixtures of the 576, 576/172, and 577/177 Curve Tracers.

- A. Transistor Adapter** — Useful for most single and dual bipolar transistors and some MOS FETs.
Order (013-0098-02) \$195
- B. FET Adapter** — Useful for most single and dual FETs.
Order (013-0099-02) \$195
- C. Long Lead Transistor Adapter** — Accepts dual or single transistors with untrimmed leads.
Order (013-0102-00) \$190
- D. Long Lead FET Adapter** — Accepts dual or single FETs with untrimmed leads.
Order (013-0103-00) \$195
- E. Integrated Circuit Adapter** — Allows connection to multipin device packages. The appropriate multilead socket is plugged into the integrated circuits adapter. The pins are then connected to the collector, base, or emitter terminals by means of the patch cord. A tie point is also provided so that an external power supply or signal source may conveniently be patched to the IC pins. Order the appropriate multilead socket listed separately.
Order (013-0124-01) Includes
8 each 4 inch test leads \$295

KELVIN SENSING ADAPTERS

The following accessories fit the test fixtures of the 576, 576/172, 576/176, and 577/177 Curve Tracers.

- A. Transistor Adapter** — Accepts long or short transistors. Can be rewired to accommodate nonstandard configurations.
Order (013-0127-01) \$65
- B. In-Line Adapter** — Accepts large and small transistors with in-line leads. The adapter will accept devices with approx spacing between terminals of 0.06 in up to 0.18 in. It is wired for a B-C-E terminal configuration but may be easily rewired for the C-B-E configuration.
Order (013-0138-01) \$75
- C. TO36 Adapter** — Order (013-0112-00) \$85
- D. TO3 Adapter** — Can be rewired to accommodate nonstandard configurations.
Order (013-0100-01) \$95
- E. TO66 Adapter** —
Order (013-0101-00) \$95
- F. Axial Lead Diode Adapter** —
Order (013-0111-00) \$95
- G. Stud Diode Adapter** —
Order (013-0110-00) \$95
- H. Blank Adapter** — For mounting special sockets.
Order (013-0104-00) \$55
- I. Power Transistor Adapter** —
Order (013-0163-00) \$95

MULTILEAD SOCKETS

These sockets are used with the Integrated Circuit Adapter (013-0124-01) listed under Dual Width Adapters, and with the 178 Test Fixture.

- A. 8 Lead TO Package** —
Order (136-0444-00) \$33
- B. 10 Lead TO Package** —
Order (136-0441-00) \$49
- C. 14 Lead Dual-in-line Package** —
Order (136-0443-00) \$27
- D. 16 Lead Dual-in-line Package** —
Order (136-0442-00) \$34

(These four sockets are the most commonly required in curve tracer applications. Additional socket configurations, including zero insertion style, are available from Textool Products, Inc., 1410 W. Pioneer Dr., Irving, TX 75061.)

The sockets you will receive have the same electrical characteristics as shown A-D above, but similar in appearance.

DIGITAL PHOTOMETER/ RADIOMETER

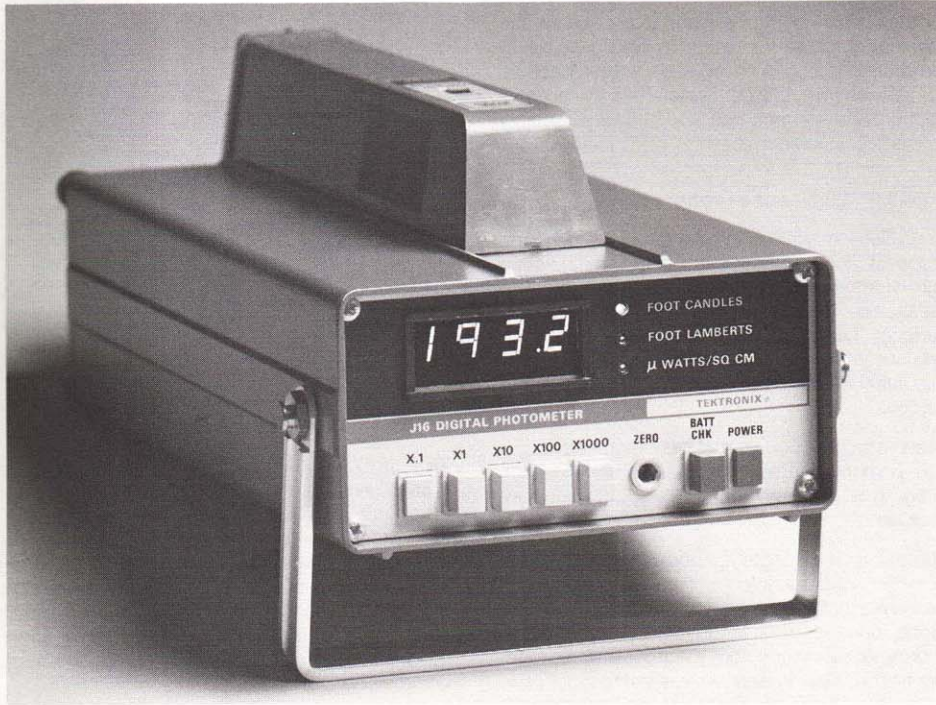

The TEKTRONIX J16 is a portable digital photometer/radiometer capable of making a wide variety of light measurements—in the laboratory or in the field.

Eight quickly interchangeable probes are available for measuring illuminance, irradiance, luminance, light-emitting diode output, and relative intensity. Recalibration is not necessary when probes are interchanged. Connection of a probe to the J16 automatically selects the correct front panel units indicator. The 3 1/2-digit LED display can be easily read under low ambient conditions. All probes use silicon photo-diodes and multi-element glass filters for maximum stability and accuracy. The excellent stability eliminates the need for routine zero adjustments.

Integrated circuits are used extensively in the J16 to achieve stable operation, low power requirements, small size, and light weight.

Under normal usage, internal rechargeable nickel cadmium batteries will only need recharging weekly. A battery charger is supplied. For continuous operation, an ac power supply is available which replaces the battery pack.

A shoulder strap provides carrying ease. The cabinet and probes have a standard threaded socket (1/4 inch x 20) for convenient mounting on a tripod or optical bench.

CONTENTS

| | |
|---------------------------------|-----|
| J16 Photometer/Radiometer | 311 |
| Illuminance Probes | 312 |
| Irradiance Probes | 312 |
| Luminance Probes | 312 |
| Uncorrected Probe | 313 |
| LED Test Probe | 313 |

J16 Photometer/Radiometer

Digital LED Readout

Freedom from Saturation
Effects over Entire Range

Metric and US Versions Available

Accurate Spectral and Cosine Corrections

Internal Rechargeable Batteries

Environmentalized

Eight Silicon Sensor Probes Quickly
Interchanged without Recalibration

J16 CHARACTERISTICS

Display — 3 1/2-digit LED readout and three LEDs automatically indicating correct units for probe in use.

Stability — Within 2% per year.

Linearity — Within 2% over the entire range, enabling single point calibration.

Integration Time — ≈ 100 ms.

Calibration — Electrical calibration of the J16 is performed by use of a calibrated voltage source or DVM traceable to NBS. Calibrated probes can be used with any J16 without additional calibration.

Power Requirements — Internal rechargeable NiCd batteries only need recharging weekly in normal usage. Two hours of continuous operation is provided. (A battery charger is supplied.) For continuous operation an ac power supply is available. This is interchangeable with the battery pack.



**J6511 and J6501
Illuminance Probes**

The J6511 is an illuminance probe with readout in footcandles (lumens/m² (lux) for the J6511 Option 02). A multi-element glass filter and silicon photodiode insure a close match to the CIE photopic curve (color corrected). The silicon-sensor recovery time is virtually instantaneous; low light levels can be measured immediately after exposure to bright sunlight.

The angular response is accurately cosine corrected, simulating an ideal 180° field-of-view detector. The low-profile probe has a leveling indicator to assure accurate measurements where a significant proportion of the illumination comes from sources at low angles to the horizon.

A 25-foot cable between the probe and J16 allows the user to be out of the field of view while making measurements. Typical applications include measurement of roadway illumination, office lighting, and illumination of work surfaces.

Where cosine correction is not necessary, a standard probe is available (J6501) with the same photopic correction and units as the J6511.



A low-profile version of the probe (J6512), physically similar (without cosine correction) to the J6511, is available for use where space is restricted.

**J6502 and J6512
Irradiance Probes**

The J6502 measures irradiance in microwatts/cm² (milliwatts/m² for the J6502 Option 02). The spectral response is flat from 450 to 950 nanometers, ±7%. The response is typically down 50% at 400 and 1030 nm. Typical applications include laser research experiments and measurements of radiant efficiency.

An optional filter holder is available to mount standard 1-inch diameter customer-supplied filters of up to 3/8 inch thickness. Where high intensity sources are used (over 1990 μWatts/cm²), neutral density filters can be used to extend the range of the J16. (An ND 1 filter has 10% transmission, an ND 2 filter has 1%, etc.) held with optional filter holders.

Where the 1 sq cm sensor is not completely filled by the source for example with a laser beam, the reading obtained represents μWatt instead of μWatts/cm² (J6502), or milliwatts x 10⁻⁴ instead of milliwatts/m² (J6502 Option 02). Small variations in sensor area can add ±5% uncertainty to this measurement.

J6503 8° Luminance Probe

The J6503 measures luminance in footlamberts (candelas/m² (nit) for the J6503 Option 02) where light scattered or emitted by a surface must be measured. The probe is pointed at the emitting surface. Typical applications include measuring brightness of television screens and street signs, and light reflected from work surfaces and movie screens.

The probe's response is closely matched to the CIE photopic curve, assuring accurate results even when measuring spectrally different light sources.

The acceptance angle is approximately 8°, which is determined by internal field stop apertures. Providing that the 8° field is uniformly filled, the probe can be held at any distance from the source. At 12 inches from the front of the probe, the field of view is approximately three inches in diameter. The footlambert or candelas/m² (nit) (J6503 opt 02) indicator automatically lights when the J6503 is connected.



Luminance Measurement of a Monitor with J16/J6503.



Measuring Luminance with the TEKTRONIX J16/J6523.

J6523 1° Luminance Probe

The J6523 will measure the luminance in footlamberts (candelas/m² for the J6523 Opt 02) of a spot as small as 0.32 inches in diameter (0.035 inches with a standard +10 diopter, 55 mm photographic close-up lens). The 1° angle represents 0.21 inches per foot of distance from the probe to the source. Thus at 10 feet, the J6523 measures a 2.1-inch diameter spot. Typical applications include measuring highway lighting, television displays and photographic equipment.

The probe includes an optical sighting system with a 9° viewing field. The focusing range is 18 inches to infinity, closer with commercially available close-up lenses. The spectral response is closely matched to the CIE photopic curve (color-corrected) for accurately measuring all commonly used light sources.

The J6523 may be attached to the J16 or used with an optional probe extension cable. A standard 1/4-20 threaded socket allows it to be used on a tripod or an optical bench.

J6504 Uncorrected Probe

This probe is designed for applications where only relative measurements need be made. The J6504 has the widest spectral range, and is the most sensitive probe. Use is made of a UV-enhanced silicon sensor and a UV-transmitting window rather than spectral-correction filters. The J6504 is useful for checking light sources used in photo-resist or photoprocessing applications and comparisons of ultraviolet light sources.

A HOLD switch allows the reading to be stored at any time. No units are indicated on the three front panel indicators when using the J6504, since it provides relative readings only.

An optional filter holder may be used to mount standard 1-inch diameter filters on standard-configuration probes. Ultraviolet, visible, or near infrared filters can be used to select the wavelength of interest and exclude ambient light.

J6505 LED Test Probe

The principal application of the J6505 is measurement of light-emitting diodes (LED) having spectral outputs in the red region (600 to 710 nm). The J6505 measures illuminance in footcandles (lumens/m² (lux) for the J6505 Option 02), which can easily be converted into luminous intensity in candelas.

An adapter supplied with the probe provides a controlled spacing between the sensor and the LED under test. The adapter excludes ambient light, and has internal baffles to prevent stray reflections during the measurement. Three inserts are supplied with the adapter to fit common sizes of LED's (0.080 inch, 0.125 inch, and 0.200 inch in diameter). These inserts are made of soft plastic that can be easily modified by the user.

With the adapter in place, a reading of 1 footcandle on the J16 represents 100 milli-candelas of luminous intensity. With a metric version of the J16/J6505 (Opt 02), 1 lumen/m² represents 10 millicandelas. A 10X increase in sensitivity is available on special order.

In the J6505, the silicon photodiode-filter combination provides an excellent match to the photopic curve in the region 600 to 710 nm. This close match requires compromising in the 380 to 600 nm region making this probe unsuitable for general illuminance measurements. For LED measurements in the yellow or green region, the adapter must be used with the J6501 and the same conversion factor for luminous intensity applies.

PROBE CHARACTERISTICS

| Application Probe | Illuminance | | Irradiance J6502/J6512 | Luminance | | Uncorrected J6504 | Red LED J6505 | |
|-----------------------------|---|--|--|--|--|--|--|--|
| | J6501 | J6511 | | J6503 | J6523 | | | |
| Range | US | 0.001 to 1999 foot-candles*† | 0.001 to 1999 foot-candles* | 0.001 to 1999 microwatts/cm ² | 0.1 to 199,900 foot-lamberts* | 0.1 to 19,990 foot-lamberts* | Relative response only | 0.001 to 1999 foot-candles*† |
| | Metric (Opt. 02) | 0.01 to 19,990 lumens/m ² (lux)*† | 0.01 to 19,990 lumens/m ² (lux) | 0.01 to 19,990 milliwatts/m ² * | 1 to 1,999,000 candelas/m ² (Nits)* | 1 to 199,900 candelas/m ² (Nits)* | Relative response only | 0.01 to 19,990 lumens/m ² (lux)*† |
| Accuracy (Including J16) | Within 5% of NBS standards and ±1 digit in last place Calibrated with a 3100° K tungsten halogen light source traceable to NBS | | Same, except calibrated with a 762 nm filter | Within 5% of NBS standards and ±1 digit in last place. Calibrated with a 3100° K tungsten halogen light source traceable to NBS. | | Probe-to-Probe accuracy ±5% with tungsten light source | Same as J6501, except calibrated with a 656 nm filter | |
| Spectral Response | Within 2% (integrated) of CIE photopic curve | | Flat within ±7% from 450 to 950 nm | Within 2% (integrated) of CIE photopic curve | | UV enhanced silicon spectral curve (250-1200 nm) | Within 2% (integrated) of CIE photopic curve from 600-710 nm | |
| Acceptance Angle | 50% sensitivity at 48° off axis | Cosine Corrected (180°) | 50% sensitivity at 48° off axis | 8 degrees | 1 degree | 50% sensitivity at 48° off axis | | |
| Stability and Repeatability | Within 2% per year | | | | | | | |
| Linearity | Within 2% over entire range enabling single point calibration | | | | | | | |

*An additional decade of sensitivity is included and is usable if the J16 is carefully zeroed and used at a relatively stable temperature.
†0.00001 to 199.9 candelas when used with 014-0047-00 LED adapter or at 3.8 inches source-to-sensor spacing. Luminous intensity readings of higher in-

tensity light sources may be easily made at correspondingly greater distances using the formula: Foot-candles x d²=candelas where d is the distance from the source to the sensor in feet. (For metric readings use lux x d²=candelas where d is distance from the source to the sensor in meters.)

TYPICAL PROBE SPECTRAL CHARACTERISTICS

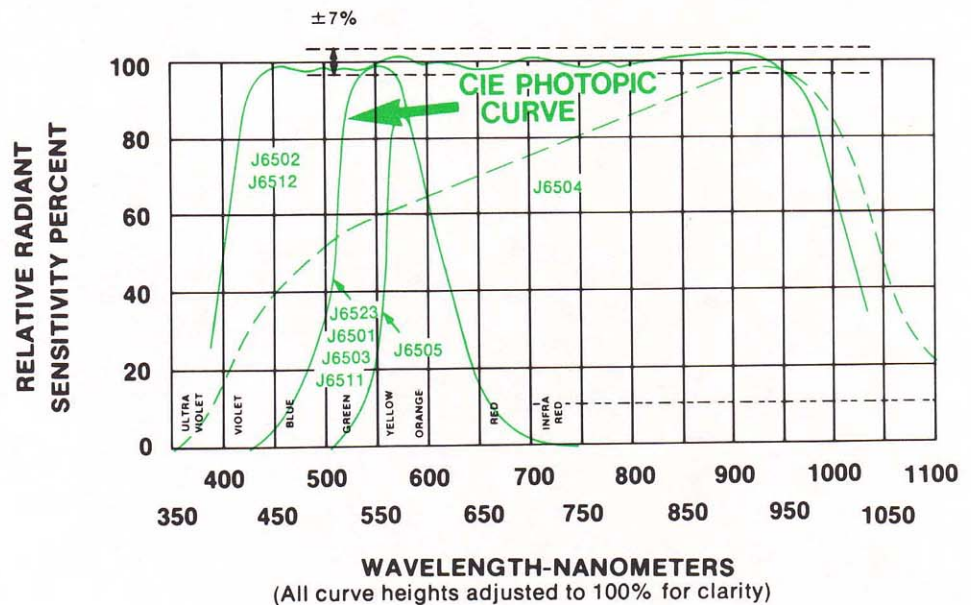

ENVIRONMENTAL CAPABILITIES

Ambient Temperature — Nonoperating, -50°C to +75°C; operating, -15°C to +40°C.

Altitude — Nonoperating, to 50,000 ft; operating, to 15,000 ft

Humidity — Operating and storage, 5 cycles (120 hr) to 95% relative humidity at 40°C. Referenced to MIL-E-16400F.

Vibration — Operating, 15 minutes along each of the 3 major axes at a total displacement of 0.025 in p-p (4 g's) from 10 to 55 to 10 Hz in 1 minute cycles. Hold for 3 minutes at 55 Hz. All major resonances must be above 55 Hz.

PHYSICAL CHARACTERISTICS

With probe and battery pack installed.

| Dimensions | in | cm |
|-------------------|------|------|
| Height | 2.4 | 6.0 |
| Width | 4.6 | 12.3 |
| Length | 8.0 | 20.3 |
| Weights (approx) | lb | kg |
| Net | 3.3 | 1.5 |
| Domestic Shipping | 5.0 | 2.3 |
| Export-packed | 10.0 | 4.5 |

INCLUDED ACCESSORIES

For Battery Operated J16 — Battery pack, battery charger, shoulder strap, manual.

For Ac Operated J16 — Ac power supply, shoulder strap, manual.

ORDERING INFORMATION

Photometer/Radiometer without Probes

| | |
|--|-----------|
| J16 115 V, 60 Hz Battery Charger | \$1060 |
| J16 Opt. 01 230 V, 50 Hz Battery Charger | No Charge |
| J16 Opt. 03 115 V, 60 Hz | No Charge |
| J16 Opt. 04 230 V, 50 Hz | No Charge |

†For a J16 with metric readout, specify Option 02 in addition to above ordering information. No additional charge. Option 02 probes are required for Option 02 J16's.

J16-TV Package — For TV color monitor set-up. The package includes J16 Battery-Operated Photometer, J6502 Irradiance Probe, Light Occluder, Probe Extension Cable.

Order J16-TV for 115 V, 60 Hz battery charger \$1670
*Refer to Readout Units of Probe Characteristics chart.

Order J16-TV Option 01
for 230 V, 50 Hz battery charger NC

For a J16-TV with metric readout, specify Option 02 in addition to above ordering information. No additional charge.

PROBES

Probe with Option 02 required for metric readout Option 02 J16s. No additional charge.

Actual spectral curve of any probe is available on initial order, at additional cost of Option 05 Add \$90

| | |
|--|--------|
| J6501 Illuminance Probe | \$520 |
| J6502 Irradiance Probe | \$520 |
| J6503 8° Luminance Probe | \$520 |
| J6504 Uncorrected Probe | \$490 |
| J6505 LED Probe, includes LED adapter | \$580 |
| J6511 Illuminance Probe cosine corrected | \$540 |
| J6512 Irradiance Probe | \$545 |
| J6523 1° Luminance Probe | \$1500 |

OPTIONAL ACCESSORIES

42 in Probe Extender Cable — Connects J16 and probe.
Order 012-0414-02 \$100

Spare Battery Pack —
Order 016-0539-01 \$135

Cables up to 30 ft in length Available on special order.

Analog & BCD Output Available on special order.
Light Occluder — For TV color monitor balancing.

Order 016-0305-00 \$22

Filter Holder — Mounts one-inch diameter filters, of up to 3/8 inch thickness, to probes (except J6511, J6512, J6514, J6523).
Order 016-0527-00 \$22

LED Adapter — Included with J6505—
Order 014-0047-00 \$80

Ac Power Supply — Allows J16 to be used without batteries.
Order 119-0404-00 115 V, 60 Hz \$200
Order 119-0404-01 230 V, 50 Hz \$215

When ordering a battery pack for your ac-powered J16, also order one of the chargers below.

Battery Charger — 115 V, 60 Hz
Order 119-0375-02 \$45

Battery Charger — 230 V, 60 Hz
Order 119-0375-03 \$50

Within the basic limitations of the silicon sensors and the J16 design, a number of modifications are possible. Contact your local Tektronix Sales Office or Representative regarding special application requirements.

Please use the return card to request data sheet and application notes describing the use of the J16.

*An additional decade of sensitivity is included and is usable if the J16 is carefully zeroed and used at a relative stable temperature.

†0.00001 to 199.9 candelas when used with 014-0047-00 LED adapter or at 3.8 in source-to-sensor spacing. Luminous intensity readings of higher intensity light sources may be easily made at correspondingly greater distances using the formula: Footcandles x d² = candelas where d is the distance from the source to the sensor in feet. (For metric readings use lux x d² = candelas where d is distance from the source to the sensor in meters.)

ACCESSORIES

CONTENTS

| | |
|-------------------------------|-----|
| Cameras & Adapters | 316 |
| Probes | 324 |
| Probe Accessories | 338 |
| Isolation Accessories | 340 |
| Carts | 344 |
| Adapters and Connectors | 346 |
| Digital Accessories | 346 |
| Mounting Accessories | 349 |
| Viewing Accessories | 350 |

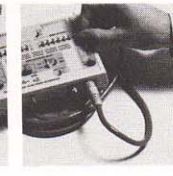
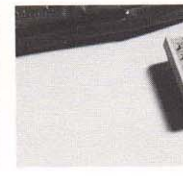
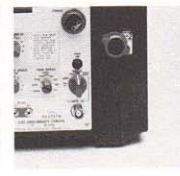
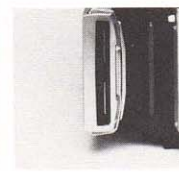
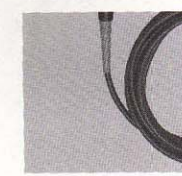
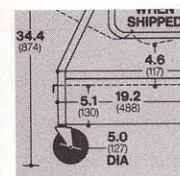
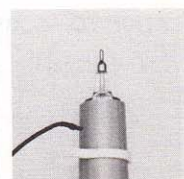
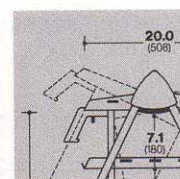
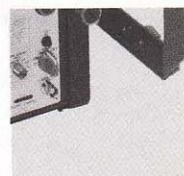
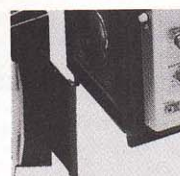
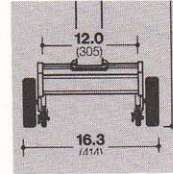
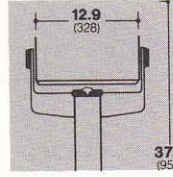
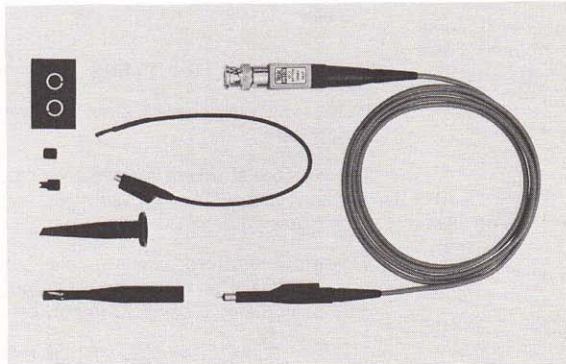
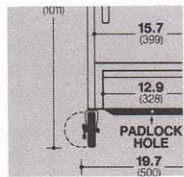
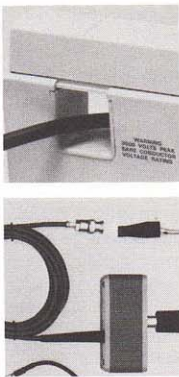
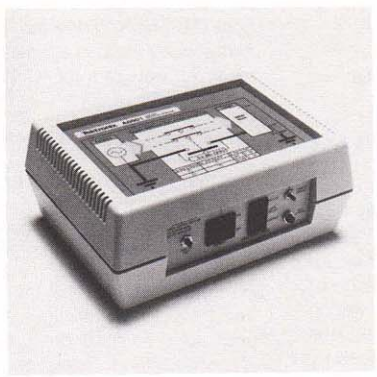

For accessory products, you can order direct by calling 800-547-1845. In Alaska, Hawaii and Oregon call collect (503) 627-5402.

Choosing a Tektronix Camera . . .

an overview of Tektronix Camera Families

A camera can be a key part of your measurement system. It allows you to capture single events and document your results, and it helps you communicate your results with clarity and credibility. The following pages give information to help you select a camera well suited to your needs.

MOUNTING

The table on page 319 indicates the camera adapters required for most Tektronix Instruments and a few by other manufacturers. In some cases, adapters are available from Hewlett-Packard or Dumont to mount Tektronix Cameras to their instruments.

LENSES

Tektronix Camera lenses differ mainly in light gathering ability, magnification, and field of view.

Speed — The f-number of a lens inversely signifies its aperture area and light gathering ability. For example: the aperture area of an f/1.4 lens is four times that of an f/2.8 lens of the same magnification and gathers four times the light. The relative light gathering ability of all lenses used in Tektronix Cameras is referenced to the f/1.9, 0.85 magnification lens which is arbitrarily rated at 1.0. For recording a stored or stable recurrent CRT display, a lens as slow as the f/16 type used in the C-5C Camera is adequate. However, to record a fast, dim, single-sweep trace, you may need a lens as fast as the f/1.2 types used in the C-31B and C-51 Cameras.

Field of View — The description for each camera includes a statement of its field of view; this signifies how large a CRT display the camera can fully record. It is determined by the combined effects of the magnification and angular field of view of the lens, any field-limiting apertures in the camera adapter, camera body, film holder, and the image area of the film.

Magnification — Modern optical technology has made possible wide-aperture, wide-angle, flat-field lenses with short focal length for more compact cameras. To realize their inherent low distortion, high resolution, and uniform focus, these fixed focal length lenses must be used at their design center magnification.

Operating such lenses at a different magnification tends to compromise their important performance characteristics. For this reason, most Tektronix Cameras are designed for use at one lens magnification. One exception is the C-30B Camera which has a magnification range of 0.7 to 1.5 (at some increase in distortion at the magnification extremes) to accommodate several portable oscilloscopes that have displays ranging in size from 3.8 x 6.3 cm to 8 x 10 cm.

The rated magnification of a lens signifies its image-to-object ratio.

For maximum resolution, the lens should produce the largest complete image possible within the image area of the film. The film most widely used for oscilloscope trace recording is Polaroid Type 107 pack film which has an image area of 73 x 95 mm. In most cases, the magnification is selected to provide the largest possible complete image of a particular display. An exception is in high writing speed applications where a 0.5 magnification lens is usually used to achieve higher writing speed by concentrating the trace light in a smaller area of the film.

SHUTTERS

There are two types of shutters: **mechanical** and **electrical**.

Mechanical shutters are simple to operate and are economical. They are actuated by pressure on a release mechanism.

Electrical shutters permit remote, automatic, or manual release and offer higher reliability. They may be actuated by an insulated switch closure.

The C-51 and C-53 electric shutters require +15 V, normally supplied by a 7000 Series Oscilloscope. An optional battery pack is available for situations where one of these cameras is used on a non-7000 Series instrument. These shutters can be actuated by a switch closure to ground. The C-28 Camera requires +15 volts at 750 mA for operation. The shutter may be actuated with either a switch closure or TTL logic.

VIEWING

Except for the C-30 Series, all Tektronix Cameras have a viewing port which provides a binocular view of the CRT. All Tektronix Cameras, except the C-5C, are hinge mounted and can be swung aside to allow a wide-angle view of the CRT. The light-weight C-5C can easily be slipped off the CRT bezel to view the CRT. The C-28 and C-50 Series Cameras have an off-axis viewing hood that accommodates eyeglasses for a comfortable binocular view of the CRT display while excluding ambient light.

FILMS

The three types of backs used on Tektronix Cameras accommodate most of the films that are used for CRT trace recording. These include sheet films, roll films, and pack films.

Polaroid films are the most convenient to use. They offer the advantages of development in seconds to a finished dry print with wide spectral response, good resolution, and high sensitivity. ASA ratings do not necessarily give a true indication of how a film will respond in CRT recording due to the narrow spectral output range of most phosphors and different spectral sensitivity of various film types.

Many different types of Polaroid film are available in rolls, packs, and 4 x 5 inch single-sheet packets. The types most used in oscilloscope and monitor photography are types 107, 612, 47, 57, 084 and 667.

Technical assistance with Polaroid film and back questions or problems is available directly from The Polaroid Corporation. Call (800) 225-1618 toll free within U.S.

Manufacture of Polaroid 410 ROLL film, ASA 10,000, has been discontinued. Polaroid 612 PACK film, ASA 20,000, is now available for most high speed applications.

BLACK BODY COLOR STANDARD

All Tektronix Cameras are supplied with a standard black body finish.

MAXIMUM MAGNIFICATION TO RECORD ENTIRE SCREEN

| | SCREEN SIZE | | | |
|---|-------------|------------|-----------|-----------------|
| | 5 x 6.3 cm | 7.2 x 9 cm | 8 x 10 cm | 9.76 x 12.2 cm |
| Polaroid pack and roll film | 1.0 | 1.0 | 0.85 | 0.67 |
| 4 x 5 sheet film | 1.0 | 1.0 | 1.0 | 0.85 or less |
| 6 x 7 cm format roll film (70 mm, 120, 220, etc.) | 1.0 | 0.67 | 0.67 | not recommended |

0.5 magnification is used for high speed recording, since reducing the size of image increases its brightness.

PHOTOGRAPHIC WRITING SPEED

Photographic writing speed signifies the ability of a particular oscilloscope/camera system to provide a useful photographic record of a fast single-sweep trace. It is stated as an oscilloscope performance characteristic and is expressed in cm/ μ s or cm/ns. It is designed to answer the question, "What is the speed of the fastest single-sweep trace the system can record?" All statements of writing speed must specify the measurement conditions, including the CRT phosphor and film used, and the definition of a readable trace image.

Film fogging is a technique for increasing the maximum sensitivity of photographic film by giving it a short exposure to dim, diffuse light. The Tektronix Writing Speed Enhancer is designed to fill this need.

The Enhancer installs in minutes, and can be triggered in three ways; by a pushbutton on the control box; remotely, with a switch closure to ground (such as provided by the camera-shutter x sync switch); or by the oscilloscope-sweep + gate.

Thus, the film can be fogged before, after, or while the sweep occurs. The techniques are respectively called prefogging, post-fogging, and simultaneous fogging. Of these modes, simultaneous fogging provides the greatest gain in writing speed. Automatic, simultaneous fogging is easily achieved by triggering the Enhancer with the oscilloscope-sweep + gate.

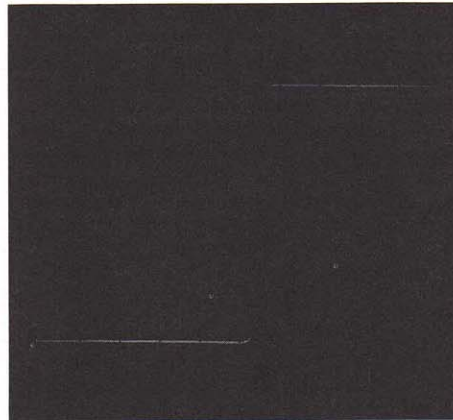

Polaroid Type 107, 3000 speed pack film was exposed to the single-trace display of a pulse waveform with a fast rising leading edge too dim to produce a developable image.

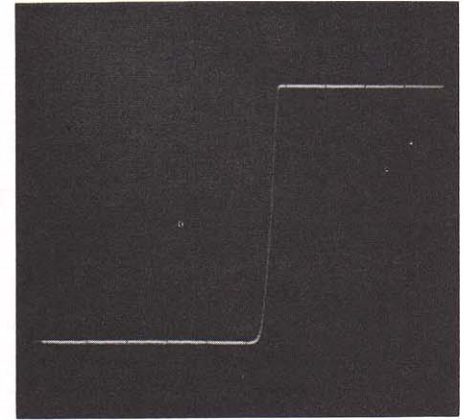

Film from the same pack was exposed to the same single-trace waveform and simultaneously to light from a Writing Speed Enhancer. The Enhancer light supplied the additional photons needed at the weak film development centers formed by the dim leading edge, to produce a visible image of the entire waveform.

POLAROID FILM

RELATIVE FILM WRITING SPEED

| ASA Equivalent Speed | Type | Unfogged | Fogged |
|----------------------|-------|------------------|--------|
| 3,000 | 667 | 1 (Reference) | 3 |
| | 107 | | |
| | 084 | | |
| | 47 | | |
| 20,000 | 612** | >2 | * |

*Not available at this time.

** Polaroid 612 PACK film, ASA 20,000, is now available with faster writing rate than previous 410 ROLL film. Writing rate specifications are not complete at this time.

The more commonly used films for each type of camera back are listed below.

POLAROID FILMS

| Film Type | ASA Equivalent Speed | Development Time (Seconds at 75°F) | Format | Resolution (Line Pairs/mm) | Characteristics | CRT Recording Uses | | | | |
|--|---------------------------|------------------------------------|----------------|----------------------------|-------------------------------------|--------------------|--------|----------------------|----------------------------|------------------------|
| | | | | | | Repetitive | Stored | TV Type (Gray Scale) | Scintillation Type Medical | Graphics Alpha-Numeric |
| PACK FILMS — Actual image size 7.3 cm x 9.5 cm (3 1/4 x 4 1/4 in) | | | | | | | | | | |
| 611* | 200 | 45 | Positive Print | 20 | Low Contrast, wide gray scale | | | X | | |
| 612** | 20,000 | 30 | Positive Print | 20-25 | High Contrast | | | | | X |
| 665 | 75 | 30 | Negative | 160-180 | Medium Contrast, wide gray scale | X | X | X | | |
| 107 | 3000 | 15 | Positive Print | 20 | Medium Contrast | X | X | | | X |
| 084** | 3000 | 15 | Positive Print | 16 | Medium Contrast | X | X | X | X | |
| 667*** | 3000 | 30 | Positive Print | 16 | Medium Contrast | X | X | X | X | |
| 108* | 75 | 60 | Positive Print | 15-17 | Color—Balanced for 5500° K | X | | X | | |
| 668* | 75 | 60 | Positive Print | 15-17 | Color—Balanced for Electronic Flash | X | | X | | |
| ROLL FILM — Actual image size 7.3 x 9.5 cm (3 1/4 x 4 1/4 in) (46L and 146L are 6.2 x 8.3 cm) | | | | | | | | | | |
| 42 | 200 | 15 | Positive Print | 25-28 | Medium Contrast, wide gray scale | X | X | X | | |
| 47 | 3000 | 15 | Positive Print | 20-22 | Medium Contrast | X | X | | | X |
| 46L | 800 | 130 | Positive Trans | 35-40 | Medium Contrast | X | X | X | | |
| 146L | 200*** 100 | 30 | Positive Trans | 40-50 | High Contrast, Blue Sensitive | X | | | | X |
| SHEET FILMS — Actual image size 8.9 x 11.4 cm (4 x 5 in) | | | | | | | | | | |
| 51 | 320*** 115 Tungsten | 15 | Positive Print | 28-32 | High Contrast, Blue Sensitive | | | | | X |
| 52 | 400 | 15 | Positive Print | 35-40 | Medium Contrast, wide gray scale | X | X | X | | |
| 55 | | | Positive Print | 22-25 | | | | | | |
| 55 P/N | 50 | 20 | Negative | 160 | Medium Contrast, wide gray scale | X | X | X | | |
| 57 | 3000 | 15 | Positive Print | 20 | Medium Contrast | X | X | | | X |
| 58* | 75 | 60 | Positive Print | 15-17 | Color—Balanced to 5500° K | X | | X | | |

*No coating required.

**Preferred for oscilloscope photography.

***Daylight rating.

A limited quantity of ROLL film camera backs is available for customers who wish to use roll films listed above. Contact your Tektronix Representative for information.

RECOMMENDED CAMERAS

(Where two or more cameras are recommended, compare features and specs to optimize for your application.)

| Oscilloscope or Display Device | Single Shot or Low Rep Rate | Stored, Stable or Repetitive | Low Cost |
|--|-----------------------------|------------------------------|---------------|
| 453, 453A, 454, 454A, 485 | C-31B | C-30B | |
| 455, 465, 465B, 468, 475, 475A | C-31B | C-30B | C-5C Opt 02 |
| 7104, 7313, 7503, 7504, 7514, 7613, 7623A, 7633, 7704A, 7904, R7903, 7834, 7844, 7854, 528 ⁴ , 544 ⁴ , T922R ⁴ , 602 ⁴ , 606 ⁴ , 606A ⁴ , 606B ⁴ , 607 ⁴ , 607A ⁴ , 492 | C-51 | C-53 ⁴ C-30B | C-5C Opt 01 |
| 577, 601, 603, 603A, 604, 604A, 605, 608, 624, 634, 1420 Series, 5100 Series, 5403/D40, 5403/D41, 5440, 5444, 7403N, 7603, 7603N11S, Telequipment D83 | | C-28* C-59A C-30B | C-5C |
| 601, 602, 603, 603A, 604, 604A, 605, 606, 606A, 607, 607A, 608, 624, 634 | | C-28* C-59A | C-5C Opt 01 |
| 432, 434, 464, 466 | | C-30B | C-5C Opt 02 |
| T900, except T922R | | | C-5C Opt 03 |
| 2200 Series | | | C-5C Opt 04 |
| 2300 Series Field Service Oscilloscopes | | | C-5C** |
| 308 Data Analyzer Field Service Instrument | | | C-5C** |
| 305, 314, 326, 335, 422, 491, 1502, 1503, SC 502, SC 503, SC 504 | C-31B | C-30B | |
| 503, 504, 530/540/550 Series, 575, 647, 647A | | C-53 ⁴ | |
| 520A, 521A, 522A, 576, 5030, 5031, 1480 Series | | C-59A | |
| 600, 5100, 5400, 7000 Series | | | C-5C Opt 01 |
| 502A, 529, 565 | | C-59A C-30B | |
| HP 5 in Round CRT ⁴ | | C-53 ⁴ | |
| HP 8 x 10 cm rectangular CRT; except 1740A and 1741A | | C-53 C-30B | |
| HP 1700 Series | | C-30B | |
| Philips 8 x 10 cm portables | | C-53 ⁴ | C-5C Opt 01** |
| HP 1332A ⁴ , HP 1333A ⁴ , HP 1335A ⁴ | | C-59A C-30B | C-5C |

*Note: The C-28 Camera is intended for, and particularly suited to, 600 Series OEM measurement applications. Contact your Tektronix Representative for information.

**Note: The C-5C can be hand held to obtain photo, but will not provide lab quality results.

¹Graticule is not illuminated and will not photograph.

²Graticule is not illuminated and will not photograph except when CRT is in the stored mode.

³A corrector lens is required to increase camera's field of view so that the full 8 x 10 cm CRT display area can be recorded. The Camera should be changed from standard to option 01, to do this order 016-0301-01 for the standard C-30 or 016-0269-04 for the standard C-31. These adapters include the adapter and corrector lens.

⁴C-51 and C-53 cameras require Battery Pack 016-0270-02 for power when not used with 7000 Series Oscilloscopes.

⁵Available from Hewlett-Packard. See HP catalogue for additional compatibility information and prices.

⁶Only the C-5C and C-59A Cameras can entirely record the 6 1/2 inch CRT display without cropping.

⁷The C-59A is suitable for the standard model Type 603 but it cannot photograph the non-illuminated graticule of the Option 01 Model.

⁸The C-59A also mounts directly onto the Type 604 but it cannot photograph the non-illuminated graticule of the standard model.

⁹Does not mount on scope, must be hand held.

¹⁰Requires 016-0288-01 adapter and corrector lens.

Adapter part numbers for cameras are available upon request. Contact your local sales office for more information.

CAMERA ADAPTER PART NUMBERS & PRICES

| | | | |
|--------------|----|-----------------|------|
| 016-0217-00 | 70 | 016-0263-00 | \$70 |
| 016-0223-01 | 50 | 016-0269-04** | 85 |
| 016-0224-01 | 55 | 016-0295-01 | 55 |
| 016-0225-04 | 55 | 016-0299-00 | 70 |
| 016-0226-01 | 70 | 016-0301-01*** | 105 |
| 016-0228-01 | 85 | 016-0306-01† | 80 |
| 016-0243-00 | 70 | 016-0327-01 | 165 |
| 016-0244-00 | 70 | 016-0342-00 | 225 |
| 016-0248-01 | 80 | 016-0357-01†† | 17 |
| 016-0249-04* | 80 | 016-0358-01††† | 17 |
| | | 016-0359-01†††† | 17 |

*(Included with C-50 Series Cameras)
 *(Adapter with lens included with C-31B Opt 01 Cameras)
 ***(Adapter with lenses included with C-30B Opt 01 Cameras)
 †(Included with C-30B, C-31B Cameras)
 ††(Included with C-5C and C-5C Opt 01 Cameras)
 †††(Included with C-5C Opt 03 Cameras)
 ††††(Included with C-5C Opt 02/ and Opt 04 Cameras)

see page 322 for extra viewing doors and flash units

C12-C19-C13-C27- Pack Film Back

These cameras are no longer produced by Tektronix. However due to customer need for a Pack Film Back these are now available. The Pack Film Back accepts to Poloroid Pack Film.

| | |
|--|-------|
| 122-0671-01 | \$210 |
| Adapters | |
| C12 to 7000 Series 016-0299-00 | \$70 |
| C12 to 530, 540, 550 Series 016-0226-01 | \$70 |
| C12 to 560 Series rectangular CRTs 016-0217-00 | \$70 |

CAMERA ADAPTER SELECTION GUIDE

| OSCILLOSCOPE OR DISPLAY DEVICE | ADAPTER PART NUMBER | | |
|--|---------------------|----------------------|--|
| | C-5C | C-50 Series and C-28 | C-30 Series |
| 528 ⁴ , 577, ² 601 ⁴ , 602 ⁴ , 603, ^{6,7} 604, ^{6,8} 604A ^{6,8} , 605 ⁴ , 606 ⁴ , 606A ⁴ 607A ⁴ , 608 ⁶ , 624 ⁶ , 634 ⁶ , 1420 Series ⁴ , 5100 Series, ^{1,6} 5403/D40, ^{6,4} 5403/D41 ⁴ , 5440 ^{4,6} 5441 ^{4,6} 5444 ^{4,6} 7104, 7313, ² 7403N, ⁶ 7503, 7504, 7514, 7603, ⁶ 7603N11S, 7613, 7623A, 7633, 7704A, R7903, 7904, 7854 7834, 7844, T922R ⁴ , HP1332A ⁴ , HP1333A ⁴ , HP1335A ⁴ , TELEQUIPMENT D83 ⁶ , 492 | 016-0357-01 | 016-0249-04 | 016-0248-01 |
| 432, ¹ 434, ² 455, 464, 465B, 466, 468, 475, 475A | 016-0359-01 | | 016-0269-03 ³ |
| T900 Series except T922R | 016-0358-01 | | |
| 2200 Series | 016-0359-01 | | |
| 308, ⁹ 2300 Series ⁹ | 016-0357-01 | | |
| 422, 453, 453A, 454, 454A, 485, 491 | | | 016-0306-01 |
| 305, 314, 326, 335, 1502, ¹ SC 502, ¹ SC 503, ² SC 504 | | | 016-0327-01 |
| 647, 647A | | 016-0223-01 | |
| 529, 561A, 561B, 564A, 564B, 568 | | 016-0224-01 | 016-0244-00 |
| 502A, 503, 504, 530 540/550 Series, 565, 575 | | 016-0225-04 | 016-0243-00 |
| 520A, 521A, 522A | | 016-0295-01 | |
| 1480 Series | | 016-0342-00 | |
| 576, 5030, 5031 | | 016-0288-01 | |
| HP 1700 Series except 1740A, 1741A, 1743A | | | HP 10106-A ⁵ |
| HP 8 x 10 cm Rectangular CRT ¹ except 1740A, 1743A | | | HP 10363-A ⁵ 016-0306-01 |
| HP 1740A, 1741A, 1743A (8 x 10 cm) | | | HP 10377-A ⁵ |
| Philips 8 x 10 cm Portables ⁹ | 016-0357-01 | | |
| HP 5 in Round CRT ¹ | | 016-0228-01 | |

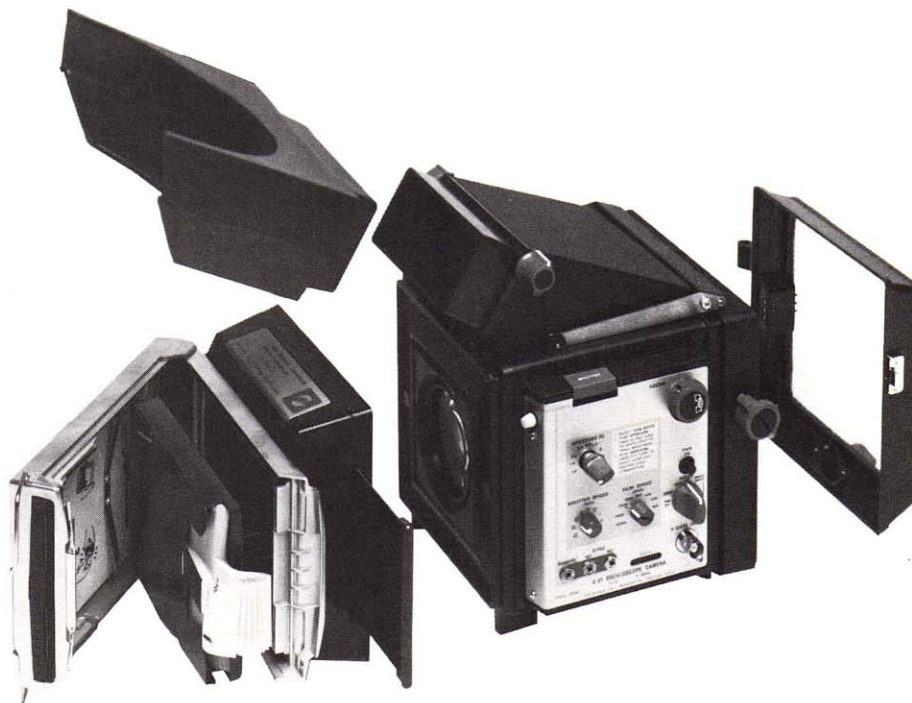

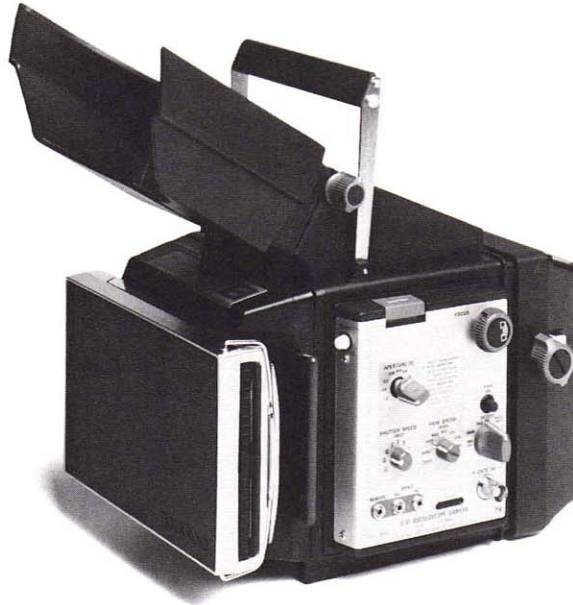

The top of the line—C-50 Series.

The three C-50 Series Cameras are designed for use with all TEKTRONIX 7000 Series Oscilloscopes, and can be adapted to fit most 5000 Series Oscilloscopes and 600 Series Display Components. Full selection of film backs, and adjustable film and shutter speeds give you the flexibility you need to best record your measurements. The photometer exposure aid, similar to light meters used in conventional photography, provides an easy way to approximate the correct exposure for repetitive or stored traces. X sync connectors allow the camera shutter to trigger the event. And each camera's built-in viewing tunnel lets you see what's on the display even when the camera is in place.

All the C-50 Series Cameras can be ordered with Polaroid pack, or the C-51 and C-59A can be ordered with a Graflok-type 4 x 5 inch back. Both backs can easily be removed and interchanged without fogging the film.

C-50 Series Cameras have black body finish.

C-51

Fastest Writing Speed

Electronic-Actuated Shutter

Photometer Exposure Aid

Range-Finder Focusing

Automatic Single-Sweep Control

This camera offers the fastest writing speed of any Tektronix oscilloscope camera. The f/1.2 lens shoots images at 0.5 magnification, clearly capturing fast transients or single sweeps, although at some expense to image size. The C-51's electric shutter can operate at speeds ranging from 1/60 to 4 seconds, and offers time, and single sweep modes by manual or remote control. The single sweep mode, available only on the C-51 and C-53 cameras, automatically opens and closes the shutter as the trace sweeps the screen. This can be especially beneficial for single-shot measurements which cannot be repeated.

C-53

General Purpose Medium Speed

Electronic-Controlled Shutter

Photometer Exposure Aid

Range-Finder Focusing

Automatic Single-Sweep Control

The C-53, like the C-51, provides an 8 x 10 cm field of view when used with Polaroid pack or roll film. Its f/1.9 lens and 0.85 magnification, however, offer somewhat slower writing speed. This camera's electric shutter also offers speeds ranging from 1/60 to 4 seconds, and can be operated manually or remotely in time, or single sweep mode. Range-finder focusing, a feature the C-53 shares with the C-51 and the C-59A, results in sharp, focused pictures every time.

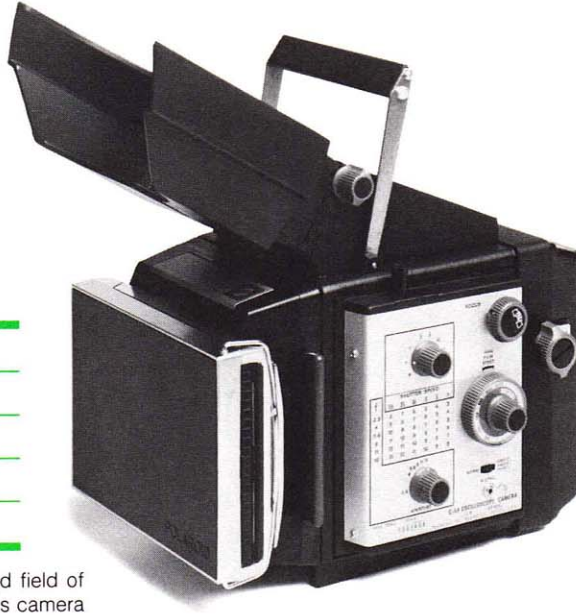

C-59A

Low-Cost

Photometer Exposure Aid

Range-Finder Focusing

Internal Battery Power

For Larger CRT'S

If you need a camera with an expanded field of view, the C-59A may be the answer. This camera is designed for CRTs up to 6 1/2 inches, and has a 10.2 x 12.7 cm field of view with Polaroid pack film. It is the only camera for the 576 Curve Tracer, and the only C-50 Series Camera for the 7603 Oscilloscope. The f/2.8 lens means slow writing speed, but it also means economy. The C-59A's mechanical shutter, operating between 1/50 and 1 second, also contributes to it slow cost. Still, many of the features of the higher-priced C-50 Series Cameras are standard on the C-59A: photo-meter exposure aid, range-finder focusing, bulb and time operating modes, X sync contacts, and film back interchangeability. An optional Adapter Frame/Corrector Lens expands the field of view to fully cover the 6 1/2 inch CRT and adjacent scale readout characters of the 576 Curve Tracer and 5030 Series Oscilloscopes. The Corrector Lens reduces the effective magnification of the C-59A from 0.67 to 0.5 so it can record the entire display on Polaroid 3 1/4 x 4 1/4 inch film.

ADAPTER FRAME/CORRECTOR LENS C-59 CAMERAS

Expands the field of view of the C-59A to fully cover the 6 1/2-in CRT and adjacent scale-readout characters of the 576 Curve Tracer and 5030 Series scopes. The Corrector Lens reduces the effective magnification of the C-59A to 0.5 so it can record the entire display on Polaroid 3 1/4 x 4 1/4 in film.

SUMMARY COMPARISON OF MAJOR CHARACTERISTICS

| CAMERA | C-51 | C-53 | C-59A |
|---|--|---|--|
| FEATURES | Fastest writing speed (at expense of image size) | General purpose for 7000 Series with 8 x 10-cm CRTs** Medium writing speed | General purpose low price. For CRTs up to 6 1/2 in; Slow writing speed |
| LENS SPEED | f/1.2 | f/1.9 | f/2.8 |
| MAGNIFICATION | 0.5 | 0.85 | 0.67 |
| RELATIVE LIGHT GATHERING ABILITY | 3.0 | 1.0 | 0.65 |
| FIELD OF VIEW | 8 x 10 cm with Polaroid pack film | 8 x 10 cm with Polaroid pack film | 10.2 x 12.7 cm with Polaroid pack film |
| SHUTTER | Electrically actuated, 4 to 1/60 s, plus Bulb and Time. Provides x sync. | | Mechanically actuated 1 to 1/125 s, bulb and time Provides x sync |

**The C-53 lens records the largest practical image of an 8 x 10-cm CRT display on Polaroid pack film.

Although the camera's photographic field is expanded to include the entire display, the view through the viewing tunnel is not. However, all but the upper one-fourth of the display can be viewed via the viewing tunnel and the camera can be swung aside to allow a full view of the entire display.

For C-59 Camera, Order 016-0288-01 \$120

PHYSICAL CHARACTERISTICS WITH FILM BACK ORDINARILY USED

| Dimensions | C-51P | | C-53P | | C-59AP | |
|---------------|-------|------|-------|------|--------|------|
| | cm | in | cm | in | cm | in |
| Height | 29.2 | 11.5 | 29.2 | 11.5 | 29.2 | 11.5 |
| Width | 19.1 | 9.8 | 19.1 | 7.5 | 19.3 | 7.7 |
| Length | 27.3 | 10.8 | 27.3 | 10.8 | 27.3 | 10.8 |
| Weight | | | | | | |
| (≈) | kg | lb | kg | lb | kg | lb |
| Net | 4.3 | 9.5 | 3.4 | 7.5 | 3.2 | 7.0 |
| Shipping | 6.8 | 15.0 | 5.4 | 12.0 | 5.0 | 11.0 |

Included Accessories — Focus Plate for Polaroid pack film (387-0893-02), or focusing screen integral with Graflok type back; mounting adapter for all 7000, 5000, and small 600 Series (016-0249-04)

ORDERING INFORMATION

"P" Models accept Polaroid pack film.

"G" Models have Graflok type backs that accept 4 x 5 in sheet film holders or roll film holders.

C-51

C-51G Camera \$1935

C-51P Camera \$1935

C-53

C-53G Camera \$1590

C-53P Camera \$1590

C-59A

C-59AG Camera \$1165

C-59AP Camera \$1165

OPTIONAL CAMERA ACCESSORIES

Mounting Adapters — see table on page 319.

Battery Pack — Provides an auxiliary + 15 V power source for the C-50, C-51, C-52, and C-53 with oscilloscopes that don't provide camera power. A three-position mode switch on the battery pack also allows the camera to be powered from a 7000 Series Oscilloscope or an external + 15 V source. Net weight of pack, including batteries, is 1.2 lb. Batteries are not included.

Order 016-0270-02 \$275

Writing Speed Enhancer — Provides automatic controlled film fogging to increase writing speed by about 3 times for 3000 ASA film and about 2 times for 10,000 ASA film. Installs in minutes.

Writing Speed Enhancer for C-51 Camera.

Order 016-0279-01 \$260

Writing Speed Enhancer for C-53 Camera.

Order 016-0300-01 \$290

Writing Speed Enhancer for C-59A Camera.

Order 016-0290-01 \$290

Polaroid Pack Film Back — Accepts Polaroid pack film. Included with "P" models.

Order 122-0926-01 \$160

Graflok Type Film Back, 4 x 5 in — Accepts Polaroid 4 x 5 in film holder, standard cut-film holders, film-pack adapters, roll-film holders (except heavy motorized models). Included with "G" models.

Order 122-0931-01 \$215

Carrying Case — Holds a complete C-50 Series Camera with extra film-backs and accessories.

Order 016-0177-00 \$260

ACCESSORIES FOR GRAFLOK TYPE BACKS

(For C-51 and C-59A)

Here are a few of the film holders available for use with the Graflok Backs to allow use of roll film, and Polaroid 4 x 5 in film. Order these accessories from the manufacturer or from your local camera store.

RH/10 120 Roll-Film Holder — 10 exposures 2 1/4 x 2 3/4 in for 4 x 5 in Graflok Backs (122-0736-01)

RH/50 70 mm Holder — 50 exposure, 2 1/4 x 2 3/4 in, for 4 x 5 in Graflok Backs only. (122-0967-00)

Polaroid Land #545 4 x 5 Film Holder — For Polaroid 4 x 5 in Single Exposure Film Packets. (016-0201-01)

Roll film holders are also manufactured by several other companies.



C-5C

Easy to Use **Modular Versatility**

Low Cost **Electric Shutter**

Graticule Illumination **Improved Lens**

The C-5C is a low-cost general-purpose camera with Polaroid Pack-film back and a graticule illuminator. It is lightweight, modular, and may be assembled with one of three interchangeable adapter hoods that fit most Tektronix Oscilloscopes and small monitors.

All three adapter hoods have an opening in the top for a lift-up viewing door or a Xenon flash unit for illuminating the CRT graticule. The flash unit has a flipdown viewing door.

Lens — Three element lens with improved focus uniformity user changeable. 0.67 or 0.85 magnification. The fixed f/16 aperture provides a wide depth of field and eliminates need for adjustable focus.

The f/16 lens has a relatively low light-gathering ability of 0.02 and is not recommended for photographing single-sweep waveforms.

Shutter — Electric with timed speeds from 0.1 to 5 seconds plus open shutter mode.

Graticule Illumination — Variable intensity Xenon flash, triggered by shutter opening, evenly illuminates the CRT screen to back-light non-illuminated graticules.

Recommended Film — Type 107, 3000-speed pack film, type 612, 20,000 speed pack film.

Field of view — Changeable: 0.67 mag—9.8 x 12.2 cm, or 0.85 mag—8 x 10 cm.

Power Source — (4) AA batteries, not included. (Use Alkiline batteries.)

Body Color — Black

Special pricing, terms and conditions are available to OEMS. Contact your local Tektronix representative for complete information.

ACCESSORIES

Adapter Hoods — (requires assembly with door or flash listed below)

Included with the C-5C and C5C Option 01 Cameras.

016-0357-01 \$17

Included with the C-5C Option 02 and 04 Camera.

016-0359-01 \$17

Included with the C-5C Option 03 Camera.

016-0358-01 \$17

Viewing Door — Fits all three adapter hoods. Mounting screws included. Included with C-5C Opt 01 and Opt 02.

016-0630-00 \$6.00

Flash Unit — Fits all three adapter hoods Mounting screws included. Included with C-5C and C-5C Opt 03 and 04.

016-0642-00 \$135

PHYSICAL CHARACTERISTICS

| Dimensions | cm | in |
|--------------|------|------|
| Height | 14 | 5.5 |
| Width | 16.8 | 6.6 |
| Length | 25.7 | 10.1 |
| Weights ≈ | kg | lb |
| Weight | 1.4 | 3 |
| Net Shipping | 1.9 | 4.1 |

| Order | For Use With | Adapter Hood (Included) Part Number | Flash Unit Included | Price |
|-------------|---|--|------------------------|----------|
| C-5C | 577, 600 Series with unilluminated graticule 1420 Series, 5100 Series | 016-0357-01 | Yes | \$500 |
| C-5C Opt 01 | 528, 600 Series w/o graticule, or with illuminated graticule, 5400 Series, 7000 Series, T922R, TELEQUIPMENT D83 | 016-0357-01 | No | Sub \$20 |
| C-5C Opt 02 | 432, 434, 455, 464, 465B, 465M, 466, 475, 475A | 016-0359-01 | No | Sub \$20 |
| C-5C Opt 03 | T900 Series except T922R | 016-0358-01 | Yes | NC |
| C-5C Opt 04 | 2200 Series | 016-0359-01 | Yes | NC |

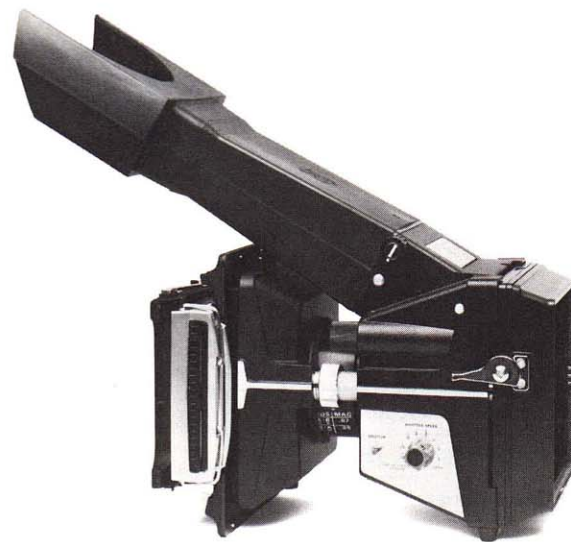

C-28

Trapezoidal Distortion Eliminated

Easy Operation

UL 544 Component Recognition

The C-28 is a high-quality recording camera for systems displaying X-Y, Y-T or gray-scale images. It is highly recommended for those using TEKTRONIX 600 Series Display Monitors. It features an f/2.8 lens with user-changeable 0.67 and 0.85 magnification ratios to record images from 8 x 10 or 10 x 12 cm CRT's. Other magnification ratios are also available as options.

The C-28 shutter is electronically controlled to provide reliable, repeatable operation and to allow remote control by the user's system. Either a TTL low logic level or a switch closure will actuate the shutter. The C-28 has a highly rigid camera body, allowing the use of heavier accessories such as 70 and 90 mm motorized roll film backs without "keystone" distortion or defocusing. The Polaroid 3 1/4" x 4 1/4" film back is easily removed, leaving a Graflok-type interface for Graflok-compatible accessories. The film back can be rotated to allow prints to be pulled to the left, to the right, or down-ward. Optional range-finder focus lights allow quick focusing without removing the film. The C-28 uses the same mounting adapters as C-27 and C-50 Series. The customer must provide a separate 15 V dc 750 mA power supply. A connector and an 18 inch power-cable assembly is included.

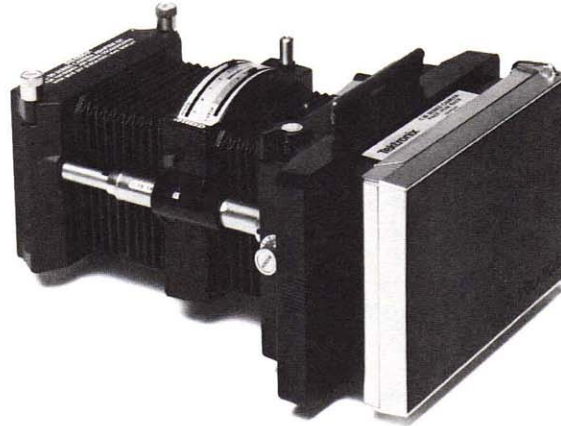

CHARACTERISTICS

Shutter Speeds — 1/50, 1/25, 1/10, 1/5, 1/2, 1 sec, and 2 secs within 20%. B (bulb) and shutter OPEN position are also provided.

Len Speed — f 2.8 to f 16.

Magnification Ratio — 0.67:1 and 0.85:1 (interchangeable).

UL 544 Component Recognition — For use in UL approved medical/dental equipment.

Dimensions

Height — Without viewing tunnel hood, 20.5 cm (8.06 in).

Width — 18.5 cm (7.25 in).

Length — 24.6 cm (9.7 in) max with Polaroid pack film lower, mounting adapter, and focus set at max extension.

Body Color — Black.

Environmental

Temperature Range — For specified performance: 0° — 50°C.

Altitude — 4500 m (15,000 ft) operating 15,000 m (50,000 ft) nonoperating.

Weight — 3.8 kg (8.5 lb) with film pack and adapter.

Standard Accessories — Shown with viewing tunnel removed.

6 pin connector and 18 in power and control cable assembly 131-1794-00, Polaroid pack film holder 352-0505-01, viewing tunnel and hood 122-0719-01.

ORDERING INFORMATION

- C-28 Camera** \$1565
- Option 01 with Focus Lights** Add \$55
- Option 02 with Graflok Focus Screen and Hood, 122-0510-00 and 122-0944-00** Add \$110
- Option 03 without Polaroid Film Back 352-0505-01** Sub \$50
- Option 04 0.8 Magnification Only** Add \$45
- Option 05 0.9 Magnification Only** Add \$45
- Option 06 Unity Magnification Only** Add \$45
- Option 08 with 016-0249-04 Adapter for 600, 7000, and 5000 Series** Add \$65

Special pricing, terms and conditions are available to OEMs. Contact your local Tektronix representative for complete information.

C-30B/C-31B

Adaptable to Many Instrument Types

The C-30B and C-31B Cameras are primarily designed for use with the 400 Series Portable Oscilloscopes, but are also adaptable to 8 x 10 cm CRT or smaller 7000, 5000, and 600 Series instruments, and to some others. See chart on page 319. The C-30B has variable magnification, permitting it to make use of the entire photo frame even with different CRT sizes. The C-31B is designed for maximum writing speed (at the expense of image size).

Option 01 is designed to fit the 8 x 10 cm display of the 455, 464, 465, 465B, 466, 475 and 475A. The standard C-30B or C-31B fits the 485.

| Camera | Lens Speed | Magnification | Relative Light Gathering Ability | Field of View |
|--------|------------|---------------|----------------------------------|---------------|
| C-30B | f/1.9 | 0.7 to 1.5 | 1.0 | 8 x 10 cm |
| C-31B | f/1.3 | 0.5 | 2.7 | 8 x 9 cm |

Shutter — Mechanically actuated, with speeds from 1 to 1/125 s plus bulb and time. Provides x sync switch closure for arming oscilloscope single sweep or initiating the event of interest.

Recommend For — 485. See page 319 for compatibility with other instruments. Also see Option 01.

Included Accessories — Split-image focusing plate for Polaroid pack back (387-0893-02); mounting adapter for 485 size bezel (016-0306-01).

PHYSICAL CHARACTERISTICS

| Dimensions | in | |
|------------|------|-----|
| | cm | in |
| Height | 13.6 | 5.4 |
| Width | 19.1 | 7.5 |
| Length | 24.9 | 9.8 |
| Weight | kg | |
| | kg | lb |
| Net | 2.2 | 4.8 |
| Shipping | 4.1 | 9.0 |

ORDERING INFORMATION

Both Models include Polaroid pack films back.

- C-30BP CAMERA** \$1245
- C-31BP CAMERA** \$1430

OPTIONS

C-30B Option 01 Expanded Field of View — f/1.9, 0.8 magnification lens covers 8 x 10 cm CRT screen without vignetting. Relative light-gathering ability is 0.9. Includes 016-0269-03 adapter for 465 size CRT bezel and corrector lens and holder. Recommended for—455, 464, 465, 465B, 466, 475, 475A.

Specify Option 01 Add \$40

C-31B Option 01, Expanded Field of View — f/1.2, 0.5 magnification lens with relative light gathering ability of 2.9 covers CRT screens up to 8 x 10 cm. Includes 016-0269-03 adapter for 465 size CRT bezel and corrector lens and holder. Recommended for—455, 464, 465, 465B, 466, 475, 475A.

Specify Option 01 Add \$40

CONVERTING OPTION 01 MODEL TO STANDARD MODEL

The Option 01 versions of the C-30B and C-31B Cameras can be converted to standard models by simply slipping off the Corrector Lens, removing the Adapter Frame, and adding an 016-0306-01 Adapter. Please refer to page 319 for prices and compatibility.

CONVERTING STANDARD MODEL TO OPTION 01 MODEL

A standard-model C-30B or C-31B can be converted to an Option 01 model by means of the appropriate Adapter Frame/Corrector Lens. 016-0301-01 for C-30B; 016-0269-04 for the C-31B. Please refer to page 319 for prices and compatibility.

OPTIONAL ACCESSORIES

Mounting Adapters — See page 319.

Writing Speed Enhancer — Increases effective film speed about 3 times for 3000 speed film. Installs in minutes.

Order 016-0284-01 \$260

Polaroid Pack Film Back — Accepts Polaroid pack film. Included with "P" models.

Order 122-0752-01 \$180

Graflok Type 4 x 5 in Back — Accepts Polaroid Land 4 x 5 in film holders, standard cut film holders, film pack adapters, roll film holders (except heavy motorized roll film holders).

Order 016-0487-00 \$230

Carrying Case — Molded high-impact plastic case with polyurethane foam liners to protect your camera in transit. 18.5 x 14.5 x 8 in.

Order 016-0587-00 \$105

X Sync Cable —

Order 012-0364-01 \$20

C-30A Portra Lens — A slip-on auxiliary lens which extends the focus distance of the camera so it can be used for off-scope photography of scenes such as test set-ups. At a distance of 21 in the camera covers 19 x 21 in. Usable with either the C-30B or C-30B Option 01.

Order 016-0246-02 \$30

Where higher frequencies (above 250 MHz) are encountered, active FET probes which have high input resistance and low input capacitance through their dynamic range should be used. For 50 Ω systems, see adjacent selection chart of 50 Ω divider probes.

FET PROBES

| Type | Attn | Length* | Package Number | Loading | | Rise time in ns | INPUT LIMITS | | | Read-Out | Page |
|-------------------|-------------------|---------|-------------------------------------|------------------------|--------------------------|-----------------|-------------------------------|----------------------------|------------------------------|-----------|------|
| | | | | | | | Max dc + pk ac | Linear Dynamic Range | Dc Offset Range | | |
| P6046 Diff/Amp | 1X 10X | 6.0 | 010-0232-00 Std | 1 MΩ 10MΩ | 10 pF 3 pF | 3.5 | ± 25 V ± 250 V | ± 5 V ± 50 V | | NO | 328 |
| P6201 FET | 1X 10X 100X | 6.0 | 010-6201-01 Std | 100 kΩ 1 MΩ 1 MΩ | 3 pF 1.5 pF 1.5 pF | 0.4 | ± 100 V ± 200 V ± 200 V | ± 0.6 V ± 6 V ± 60 V | ± 5.6 V ± 56 V ± 200 V | YES | 327 |
| P6202A FET | 10X 100X | 2m | 010-6202-03 Std W/010-0384-00Atn | 10 MΩ 10 MΩ | 2 pF 2 pF | 0.7 0.7 | ± 200 V ± 200 V | ± 6 V ± 60 V | ± 55 V ± 200 V | YES NO | 327 |

For rise time measurements, the interaction of the probe capacitance with the source impedance is of importance (RC time constant). For best results, the capacitance should be kept minimal. Typical probe specifications represent their response to a 25 Ω source environment.

50 Ω DIVIDER PROBES—For use with 50 Ω input amplifiers

| Type | Attn | Length* | Package Number | Loading | | Rise Time in ns | INPUT LIMITS | | Read-Out | Page |
|-------|------|------------|--------------------------------|---------|------|-----------------|----------------|----------------------|----------|------|
| | | | | | | | Max dc + pk ac | Linear Dynamic Range | | |
| P6056 | 10X | 6.0 9.0 | 010-6056-03 Std 010-6056-05 | 500 Ω | 1 pF | 0.1 | ± 16 V | ± 16 V | YES | 328 |
| P6057 | 100X | 6.0 9.0 | 010-6057-03 Std 010-6057-05 | 5 kΩ | 1 pF | 0.25 | ± 50 V | ± 50 V | YES | 328 |

*Length in feet except where specified.

For measuring currents from dc to 1000 A, see the adjacent selection chart for current probes.

CURRENT PROBES

Current probes can be used where low loading of the circuit is necessary. Loading is typically in the milliohm to low ohm range. Current probes can be used for differential measurements, where the probe measures the results of two opposing currents in two conductors in the jaw of the probe.

A current waveform may be very different from a voltage waveform in a current-dependent circuit. Measuring only the voltage will not show this difference. To obtain the total picture, a measurement of the current waveform is necessary.

| Type | Bandwidth Hz to MHz | Current/Div Scope at | | SATURATION | | MAXIMUM CURRENT | | | Peak Pulse Amp | Page | |
|-------------------------------|---------------------|----------------------|-------------|------------|-------------------------|-----------------|------------|---------|----------------|------|-------------|
| | | 10 mV/div | mA/mV | Dc Amps | Pulse Amp-S Product | dc + pk ac Amp | ac p-p Amp | Derate | | | |
| | | | | | | | | Below | | | Above |
| A6302/ AM 503 | dc 50 | 1 mA to 5A | | 20 | 100x10 ⁻⁶ | 20 | 40 | | 1 MHz | 50 | |
| A6302/ AM 503 with CT-5 | 0.5 20 | 20 mA to 5 kA* | | | 0.1 | | 40 k | 20 Hz | 1.2 kHz | 50 k | 277 329 |
| A6303/ AM 503 | dc 15 | 10 mA to 50 A | | 100 | 10,000x10 ⁻⁶ | 100 | 200 | | 20 kHz | 500 | 277, 239 |
| P6021 Passive Term | 120 60 | | 2 or 10 | 0.5 | 0.5x10 ⁻³ | | 15 | 300 Hz | 5 MHz | 250 | 330 |
| 134 | 12 38 | 1 mA to 1A** | | 0.5 | 0.5x10 ⁻³ | | 15 | 230 Hz | 5 MHz | 15 | |
| CT/5 Passive Term | 120 20 | | 40 or 10 kA | 20 | 0.5 | | 2000 | 300 Hz | 1.2 kHz | 50 k | 331 |
| CT-5/ 134 | 12 20 | 20 mA to 1 kA** | | 20 | 0.5 | | 2000 | 230 Hz | 1.2 kHz | 15 k | |
| P6022 Passive Term | 8.5 k 200 | | 1 or 10 | 0.2 | 9x10 ⁻⁶ | | 6 | 3 kHz | 10 MHz | 100 | 330 |
| 134 | 100 65 | 1 mA to 1A** | | 0.2 | 9x10 ⁻⁶ | | 6 | 1.3 kHz | 10 MHz | 15 | |
| CT-1 | 30 k 1000 | | 5 mV/mA | 0.2 | 1x10 ⁻⁶ | | 1.4 | | | 100 | 331 |
| CT-2 | 1.2 k 100 | | 1 mV/mA | 0.2 | 50x10 ⁻⁶ | | 7 | | | 100 | 331 |

*Scope at 10 mV/div

**Scope at 50 mV/div

Recommended Probes—For 7000 Series see page 152, for 5000 Series see page 206, for 400 Series see the individual instrument description.

OTHER PROBES

| Probe | Package Number | Function | Use | Page |
|--------|----------------|--|--|---------------|
| P6048 | 010-0215-00 | Low Capacitance 1 pF, 1 kΩ | 400 Series | 328 |
| P6058A | 010-0260-00 | Temperature and Voltage Probe | DM 501, DM 501A 7D13 | |
| P6430 | 010-6430-00 | Temperature Probe | DM 44, DM 502 | 233,326 |
| P6104 | 010-6104-00 | Voltage Probe | 465M | 326 |
| 40 kV | 010-0277-00 | High Voltage Probe | DM 501A DM 502A | |
| P6451 | 010-6451-03 | Data Acquisition Probe | 7D01 | 66,326 |
| P6401 | 010-6401-01 | Logic Probe | TTL Logic | 66,326 348 |
| P6406 | 010-6406-01 | Word Recognizer | 308 | 66 |
| P6420 | 010-6420-03 | RF Probe | DM 501A DM 502A DM44 | 300,327 |
| P6601 | 010-6601-01 | Temperature Probe | DM 501A DM 502A, 7D13 | 256 |
| P6125 | 010-6125-01 | Digital Counter /Timer Probe, 5X Attenuation | DC 503A DC 504 DC 505A DC 508 DC 509 | 264,300 |

For amplitude measurements, the capacitance and resistance of the probe form a voltage divider with the circuit under test. For low frequency (about 5 MHz and below), the resistive component is of primary importance in most probes and should be at least two orders of magnitude greater than the circuit source imped-

ance. For higher frequencies (greater than about 30 MHz), the importance of the capacitance increases drastically and will become the prime consideration.

For general-purpose use, passive voltage probes offer a wide probe selection for a variety of

applications for 1 MΩ inputs.

Modular probes are an exciting new concept in probe design. The P6101, P6105, P6106, P6107, P6108, P6120 and P6149 Probes divide into three modules (probe heads, cables, and connector/compensation boxes).

VOLTAGE PROBES FOR 1 MΩ INPUTS

MODULAR

| Type | Atten | Length* | Package Number | Loading | | Useful BW MHz | Dc Max | Scope C in pF | Readout | Page |
|-------|-------|---------|----------------|---------|---------|------------------|--------|---------------|---------|---------|
| | | | | | | | | | | |
| P6101 | 1X | 1 m | 010-6101-01 | 1 MΩ | 32.0 pF | 34 | 500 V | ANY | — | 332 |
| | | 2 m | 010-6101-03 | | 54 | 15.5 | | | | |
| | | 3 m | 010-6101-05 | | 78 | 8 | | | | |
| P6105 | 10X | 1 m | 010-6105-01 | 10 MΩ | 10.5 pF | 100 | 500 V | 15 to 47 | YES | 332 |
| | | 2 m | 010-6105-03 | | 13.0 | 100 | | | | |
| | | 3 m | 010-6105-05 | | 15.5 | 95 | | | | |
| P6106 | 10X | 1 m | 010-6106-01 | 10 MΩ | 10.5 pF | 300 ⁶ | 500 V | 15 to 24 | YES | 333 |
| | | 2 m | 010-6106-03 | | 13.0 | 250 | | | | |
| | | 3 m | 010-6106-05 | | 15.5 | 150 | | | | |
| P6107 | 10X | 2 m | 010-6107-03 | 10 MΩ | 13.0 pF | 100 ⁶ | 500 V | 15 to 47 | YES | 333 |
| P6108 | 10X | 1 m | 010-6108-01 | 10 MΩ | 10.5 pF | 100 | 500 V | 15 to 47 | NO | 332 |
| | | 2 m | 010-6108-03 | | 13.0 | 100 | | | | |
| | | 3 m | 010-6108-05 | | 15.5 | 95 | | | | |
| P6120 | 10X | 1.5 m | 010-6120-01 | 10 MΩ | 14.0 pF | 60 | 500 V | 15 to 47 | NO | 332 |
| | | 3 m | 010-6120-01 | 10 MΩ | 17.0 | 60 | 500 V | | | |
| P6125 | 5X | 1.5 m | 010-6125-01 | 5 MΩ | 20.0 pF | 200 | 250 V | 15 to 33 | NO | 264,300 |
| P6149 | 10X | 2 m | 010-6149-03 | 10 MΩ | 15.5 pF | 50 | 500 V | 20 to 62 | NO | 333 |

VOLTAGE PROBES FOR 1 MΩ Inputs

MONOLITHIC

| Type | Atten | Length* | Package Number | Loading | | Useful BW MHz | Dc Max | Scope C in pF | Readout | Page |
|--------------------|-----------|---------|--|-----------|---------------------|---------------|--------|---------------|------------------|------|
| | | | | | | | | | | |
| P6006 | 10X | 3.5 | 010-0127-01 | 10 MΩ | 7.5 pF ² | 35 | 600 V | 15 to 55 | NO | 334 |
| | | 6 | 010-0160-00 | | 8.5 | 25 | | | | |
| | | 9 | 010-0146-00 | | 11 | 25 | | | | |
| | | 12 | 010-0148-00 | | 15 | 12 | | | | |
| P6007 | 100X | 3.5 | 010-0150-00 | 10 MΩ | 2 pF ² | 25 | 1.5 kV | 15 to 55 | NO | 334 |
| | | 6 | 010-0165-00 | | 2.2 | 20 | | | | |
| | | 9 | 010-0152-00 | | 2.4 | 15 | | | | |
| | | 12 | 010-0154-00 | | 2.6 | 13 | | | | |
| P6008 | 10X | 3.5 | 010-0129-00 | 10 MΩ | 7.5 pF | 100 | 600 V | 12 to 47 | NO | 335 |
| P6008 | 10X | 6.0 | 010-0129-01 | 10 MΩ | 7.5 pF | 100 | 600 V | 12 to 47 | NO | 334 |
| | | | Environmentalized -50°C to +150°C | | | | | | | |
| P6009 | 100X | 9 | 010-0170-00 | 10 MΩ | 2.5 pF | 120 | 1.5 kV | 12 to 47 | NO | 335 |
| | | 9 | 010-0264-01 | | 2.5 | 100 | | | YES | |
| P6010 | 10X | 3.5 | Furnished with S-5. For other uses see P6105 or P6106. | | | | | | | |
| P6015 | 1000X | 10 | 010-0172-00 | 100 MΩ | 3 pF | 75 | 20 kV | 12 to 47 | NO | 335 |
| P6028 | 1X | 3.5 | 010-0074-00 | 1 MΩ | 50 pF | 17 | 600 V | ANY | YES | 336 |
| | | 6 | 010-0075-00 | | 67 | 10 | | | | |
| | | 9 | 010-0076-00 | | 90 | 7 | | | | |
| | | 12 | 010-0077-00 | | 112 | 4 | | | | |
| P6048 | 10X | 6 | 010-0215-00 | 1 kΩ | 1 pF | 100 | 20 V | 15 to 20 | NO | 328 |
| P6053B | 10X | 3.5 | 010-6053-11 | 10 MΩ | 9.5 pF | 200 | 500 V | 15 to 24 | YES | 336 |
| | | 6 | 010-6053-13 | | 12.5 | 200 | | | | |
| | | 9 | 010-6053-15 | | 13.5 | 115 | | | | |
| P6055 ² | 10X | 3.5 | 010-6055-01 | 1 MΩ | 10 pF | 60 | 500 V | 20 to 47 | YES | 336 |
| P6060 ² | 10X | 3.5 | 010-6060-01 | 10 MΩ | 7.5 pF ² | 35 | 600 V | 15 to 55 | YES ⁴ | 337 |
| | | 6 | 010-6060-03 | | 8.5 | 25 | | | | |
| P6062B | 10X or 1X | 3.5 | 010-6062-11 | 10 MΩ | 13.5 pF | 100 | 500 V | 15 to 47 | YES | 337 |
| | | | | 1 MΩ | 100 | 8 | | | | |
| | 10X or 1X | 6 | 019-6062-13 | 10 MΩ | 14 | 100 | | | | |
| | | | | 1 MΩ | 105 | 6 | | | | |
| P6063B | 10X or 1X | 3.5 | 010-6063-11 | 10 MΩ | 11.0 pF | 200 | 500 V | 15 to 24 | YES | 337 |
| | | | | 1 MΩ | 80.0 | 12 | | | | |
| | | | | 10X or 1X | 6 | 010-6063-13 | | | | |
| | | | | 1 MΩ | 105.0 | 6 | | | | |

Length in feet except where specified.

1. To convert to uhf connectors, use adapter 103-0015-00.

2. Rating varies with scopes having other than 20 pF inputs.

3. Designed for use with scopes having differential inputs.

4. Not compatible with CRT readout.

5. 25 Ω source.

6. Typically 300 MHz at probe tip with scope bandwidth at least 325 MHz.

7. Trace identification button.

| INSTRUMENT | PROBES | | |
|--|-----------------------------------|-------------------------|---|
| | PASSIVE | ACTIVE | CURRENT |
| 7000 SERIES | | | |
| 7A11 | Built in FET Probe | | A6302/AM 503 A6303/AM 503 |
| 7A13 | P6055 P6101 P6060 P6062B | P6015 P6009 P6105 | P6021 P6022 |
| 7A15A | P6101 P6105 P6062B | P6015 P6009 | P6021 P6022 |
| 7A16A | P6106 P6101 P6063B | P6015 P6009 | P6201 P6202 P6021 P6022 A6302/AM 503 |
| 7A18 | P6101 P6105 P6062B | P6015 P6009 | P6021 A6302/AM 503 |
| 7A19 | P6056 P6057 | | P6021 P6202 P6022 A6302/AM 503 A6303/AM503 |
| 7A22 | P6101 P6055 P6060 P6062B | | P6021 A6302/AM 503 |
| 7A24 | P6056 P6057 | | P6201 P6202 P6022 A6302/AM 503 A6303/AM 503 |
| 7A26 | P6101 P6101 P6063B | P6015 P6009 P6048 | P6201 P6202 P6022 A6302/AM 503 A6303/AM 503 |
| 7A29 | P6056 P6057 | | P6201 P6202 A6302/AM 503 A6303/AM 503 |
| 5000 SERIES | | | |
| 5A14N | P6101 P6108 P6062B | P6015 P6007 P6120 | A6302/AM 503 P6021 |
| 5A15N | P6101 P6108 P6062B | P6015 P6007 P6120 | A6302/AM 503 P6021 |
| 5A18N | P6101 P6108 P6062B | P6015 P6007 P6120 | P6021 A6302/AM 503 |
| 5A21N | P6101 P6055 P6060 | | P6021 |
| 5A22N | P6101 P6055 P6060 | | |
| 5A26 | P6101 P6060 P6055 | | P6021 |
| 5A38 | P6101 P6105 P6062B | P6015 P6009 P6120 | P6021 P6022 A6302/AM 503 |
| 5A45 | P6101 P6105 P6062B | P6015 P6009 P6120 | P6021 P6022 A6302/AM 503 |
| 5A48 | P6101 P6105 P6062B | P6015 P6009 P6120 | P6021 P6022 A6320/AM 503 |
| TM 500 SERIES | | | |
| AM 502 | P6055 P6060 | P6101 P6028 | P6021 |
| AM 503 | | | A6302 A6303 |
| DM 501A DM 502A DM 505 | P6420 40 kV(010-0277-00) | | |
| DC 503A DC 504 DC 505A DC 509 | P6125 P6108 | | |

| INSTRUMENT | PROBES | | |
|---|---|------------------------------|--|
| | PASSIVE | ACTIVE | CURRENT |
| TM 500 SERIES | | | |
| DC 508A | P6125 P6108 | | P6056 |
| SC 501 SC 502 SC 503 | P6101 P6028 P6108 P6060 | | P6062B P6007 P6013A P6015 |
| SC 504 | P6101 P6108 | | P6062 P6009 P6021 P6022 |
| 400 SERIES | | | |
| 485 | P6101 P6106 P6056 P6057 P6063B | P6015 P6009 P6048 | P6201 P6202 P6021 P6022 A6302/AM 503 A6303/AM 503 |
| 475A 475 | P6101 P6106 P6063B | P6015 P6009 P6048 | P6201 P6202 P6021 P6022 A6302/AM 503 A6303/AM 503 |
| 465B 465 468 | P6101 P6105 P6062B | P6015 P6009 P6048 | P6201 P6202 P6021 P6022 A6302/AM 503 A6303/AM 503 |
| 465M | P6101 P6104 | P6015 P6009 | P6201 P6202 P6021 P6022 A6302/AM 503 A6303/AM 503 |
| 455 | P6101 P6105 P6062B | P6015 P6009 | P6202 P6021 P6022 A6302/AM 503 A6303/AM 503 |
| 466 464 | P6101 P6105 P6062B | P6015 P6009 | P6202 P6201 P6021 P6022 A6302/AM 503 A6303/AM 503 |
| 434 | P6101 P6108 P6009 P6015 | P6120 | P6021 P6022 A6302/AM 503 A6303/AM 503 |
| 300 SERIES | | | |
| 308 | P6107 | | P6404 P6451-05 |
| 314 | P6101 P6149 | | P6021 P6022 A6302/AM 503 A6303/AM 503 |
| 335 | P6101 P6149 | | P6021 P6022 A6302/AM 503 A6303/AM 503 |
| 326 | P6101 P6149 | | P6021 P6022 A6302/AM 503 A6303/AM 503 |
| 323 | P6101 P6149 | | P6021 P6022 A6302/AM 503 A6303/AM 503 |
| T900 SERIES | | | |
| T935A T932A T922R T921 T912 | P6101 P6108 P6062B P6009* P6015 | P6120 P6006** P6007*** | P6021 P6022 A6302/AM 503 A6303/AM 503 |
| 2200 SERIES | | | |
| 2213/2215 | P6120 | | |

*For T935A and T932A only
 **For T932A and T912 only
 ***For T922R, T921 and T912 only

P6201 Dc to 900 MHz

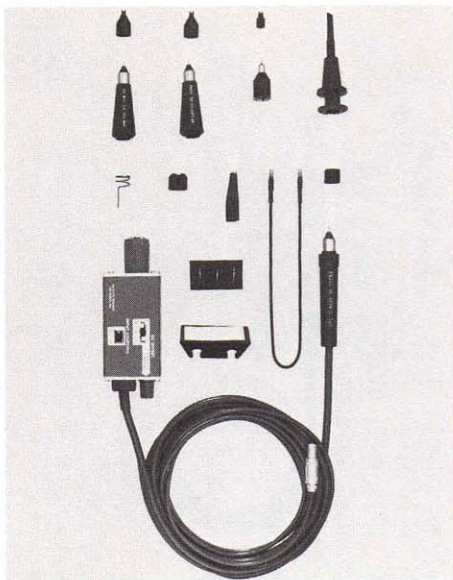

Unity Gain

Two Plug-on Attenuator Heads that Maintain Scope Readout Factor

Low Input Capacitance

Dc Offset

Ac-Dc Coupling Switch

The P6201 is an active (FET) probe providing unity gain and dc to 900 MHz bandwidth. The P6201 is the best general-purpose probe within its voltage range from the standpoint of electrical performance. Very low input capacitance permits acquisition of high frequency signals with minimum loading of circuits under test while high input resistance minimizes low frequency and dc loading. Plug-on attenuator heads provide higher input resistance and reduced input capacitance. The probe derives its power from the probe power jack on many Tek scopes or a 1101 power supply.

CHARACTERISTICS

Bandwidth — Dc to 900 MHz (–3 dB). **Rise Time** — 0.4 ns or less. **Probe Gain** — 1X within 3%. **Attenuator Accuracy** — < 4% with probe (10X and 100X). **Input Impedance** — Probe only, 100 k Ω within 1%, shunted by \approx 3.0 pF. Attenuator heads are 1 M Ω within 1%, shunted by 1.5 pF or less.

Dynamic Signal Range — At least \pm 600 mV; extended to \pm 6 V with 10X Attenuator; \pm 60 V. **Dc Offset Range** — At least –5.6 to +5.6 V without attenuator head. Effective offset is extended by 10X and 100X attenuator heads to \pm 56 V and \pm 200 V, respectively. **Noise** — 300 μ V or less at output (measured tangentially). **Maximum Input Voltage** — \pm 100 V, probe only; \pm 200 V with attenuator heads, derating with frequency. **LF Response** — 10 Hz or lower, –3 dB, ac coupled; 10X attenuator extends LF response to \leq 1 Hz; with 100X attenuator, LF response is \leq 10 Hz.

INCLUDED ACCESSORIES

- 013-0135-00 1 TIP, probe, retractable (BT)
- 010-0376-00 1 ATTENUATOR head 10X
- 010-0377-00 1 ATTENUATOR head 100X
- 206-0200-00 3 TIP, probe (CO)
- 131-1302-00 1 CONTACT, ground (CG)
- 175-0848-02 1 LEAD, ground, 30 cm (12 in) (BB)
- 103-0164-00 1 TIP, probe (CD)
- 344-0046-00 1 CLIP, alligator (AU)
- 166-0557-00 1 INSULATING SLEEVE, electrical (CJ)
- 342-0180-00 1 INSULATOR, ground contact (CT)
- 016-0156-02 1 CARRYING CASE

ORDERING INFORMATION

- P6201 FET Probe, 010-6201-01 \$990
- 1101 Accessory Power Supply, Powers up to four P6201 or P6202A Probes. 1101 \$515

P6202A Dc to 500 MHz

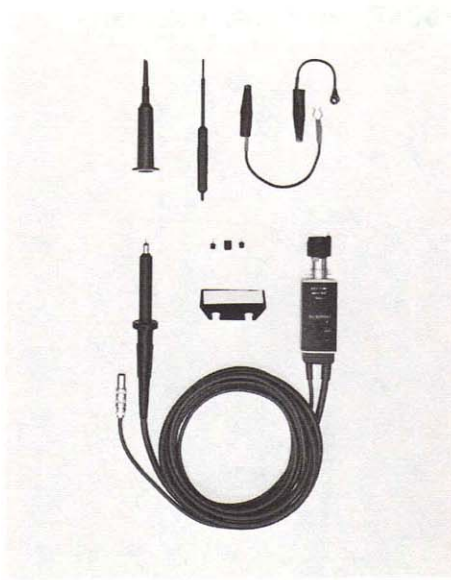

Dc Offset

High Input Impedance through Freq Range

Small Probe Size

With its standard Tektronix power connector the P6202A can be used on any instrument which has standard probe power. The very low input capacitance of the probe permits acquisition of high frequency signals with a minimum loading of circuits under test while the high input resistance minimizes low frequency and dc loading.

The probe has a dc offset feature to offset any dc component within the range of the control to bring the signal into the dynamic range of the probe.

The P6202A derives its power from the probe power jack on many of Tek scopes or a 1101 power supply.

CHARACTERISTICS

Probe and (Opt 10X Attenuator Head):

Bandwidth — Dc to \geq 500 MHz (–3dB). **Rise Time** — 0.7 ns or less. **Attenuation** — 10X within 4% (100X within 2% for Opt 10X Attenuator Head). **Input Impedance** — 10 M Ω within 2% shunted by \approx 2 pF. **Dynamic Range** — 0 to \pm 6 V. **Dc Offset Range** — –55 V to +55 V (–200 V to +200 V for Opt 10X Attenuator Head). **Noise** (Tangential) — 150 μ V or less. **Max Safe Input Voltage** — 200 V dc + peak ac, derated with frequency.

Opt Ac Coupling Cap:

Bandwidth — 16 Hz to \geq 500 MHz (–3 dB). **Rise Time** — 0.7 ns or less. **Input Impedance** — \approx 4 pF. **Max Safe Input Voltage** — 200 V dc + peak ac.

INCLUDED ACCESSORIES

- 013-0097-01 1 TIP, probe, retractable (BO)
- 352-0351-00 1 HOLDER, probe
- 344-0046-00 2 CLIP, alligator (AU)
- 175-0849-00 1 LEAD, ground, 7.5 cm (3 in) (BC)
- 016-0378-00 1 CARRYING CASE
- 003-0675-01 1 ADJUSTMENT TOOL, probe (CU)
- 175-1017-00 1 LEAD, ground, 13 cm (5 in) (BE)
- 166-0404-01 2 TIP, probe, replaceable*
- 166-0404-01 1 INSULATING SLEEVE, electrical (CH)

*Available in package of 10 only, order 206-0230-03 (CR).

ORDERING INFORMATION

- P6202A FET Probe, 2 Meter Cable, 010-6202-03 \$530
- OPTIONAL ACCESSORIES**
- P6202A 10X Attenuator, 010-0384-00 \$60
- P6202A Ac Coupling Cap, 010-0360-00 \$30

Included Accessories with double alpha codes are pictured on pages 338 and 339.

P6420 RF Probe

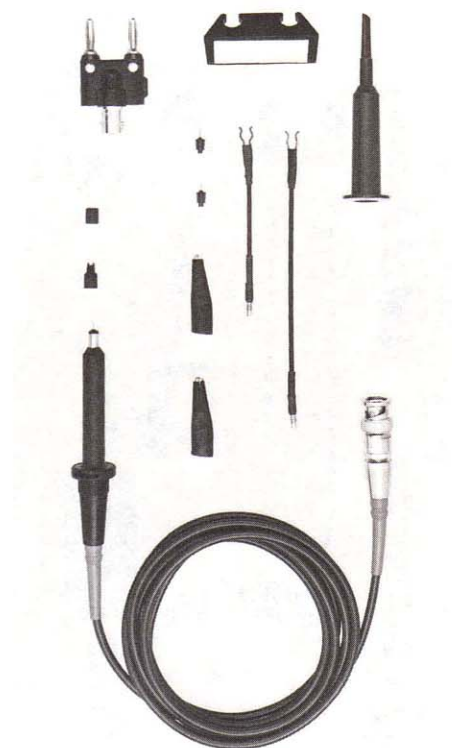

RF Probe

10 kHz to 1 GHz Bandwidth

Dc V output/RMS of Sine input

The P6420 RF probe measures high frequency ac voltage from 10 kHz to 1 GHz. It provides a dc output voltage proportional to the RMS value of a sinewave input.

CHARACTERISTICS

Voltage Range — 0.5 V to 25 V RMS (70.7 V p-p). **Ac to Dc Transfer Ratio Accuracy** — 0.5 V to 5 V RMS \pm 10% (15°C to 35°C). 5.0 V to 25 V RMS \pm 5% (15°C to 35°C). **Frequency Response** — 100 kHz to 300 MHz (\pm 0.5 dB). 50 kHz to 500 MHz (\pm 1.5 dB), 10 kHz to 1 GHz (\pm 3.0 dB). **Input Capacitance** — \approx 3.7 pF. **Maximum Input Voltage** — 42.4 V (peak ac + dc). **Temperature Range** — Nonoperating: –55°C to +75°C. Operating: +15° to +35°C. **Length** — Probe only 9.6 cm. Cable only 2 meters.

INCLUDED ACCESSORIES

- 013-0097-01 1 TIP, probe, retractable (BO)
- 344-0046-00 2 CLIP, alligator (AU)
- 175-0849-00 1 LEAD, ground, 7.5 cm (3 in) (BC)
- 175-1017-00 1 LEAD, ground, 13 cm (5 in) (BE)
- 166-0404-01 1 INSULATING SLEEVE, electrical (CH)
- 352-0351-00 1 HOLDER, probe
- 103-0090-00 1 ADAPTER, BNC female to dual banana(BN)
- 2 TIP, probe, replaceable*

*Available in package of 10 only, order 206-0230-03 (CR).

ORDERING INFORMATION

- P6420 RF Probe, 2 m Cable Included, 010-6420-03 \$120
- For a 1 meter length cable only, (does not change specifications) 175-1661-00 \$26
- For a 3 meter length cable only, (does not change specifications) 175-1661-02 \$26

P6048 Dc to 200 MHz 10X

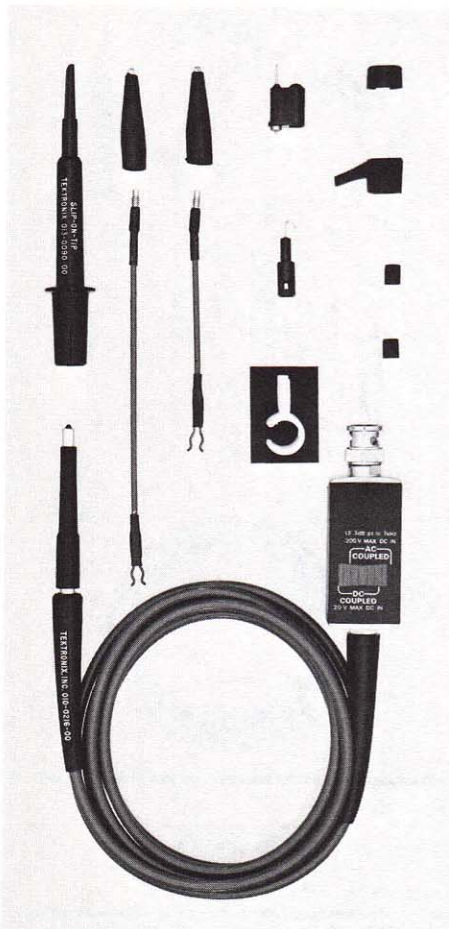

Low Capacitance 1 pF- 1 kΩ

Ac/dc Switch

The P6048 is a miniature low capacitance probe for use with 1 MΩ 20 pF oscilloscopes. The probe input impedance of 1 kΩ paralleled by 1 pF is intended for applications where capacitor loading may distort the circuit waveforms. Ac or dc coupling switch is available to extend the measurement range.

CHARACTERISTICS

Attenuation — 10X. **Input Resistance** — 1 KΩ. **Input Capacitance** — 1 pF or less. **Maximum Input dc** — 20 V; Ac 200 V. **Ac Low Frequency** — 7 kHz or less. **Bandwidth** — (with 250 MHz oscilloscope with 1 MΩ/20 pF input) 175 MHz. **Typical Probe Risetime** — 1.95 ns.

INCLUDED ACCESSORIES

- 013-0085-00 1 TIP, probe, bayonet (BM)
- 013-0090-00 1 TIP, probe, retractable hook (BN)
- 166-0404-01 2 INSULATING SLEEVE, electrical (CH)
- 166-0433-00 1 INSULATING SLEEVE, ground lead (CI)
- 175-0124-01 1 LEAD, ground, 13 cm (5 in) (AW)
- 175-0263-01 1 LEAD, ground, 7.5 cm (3 in) (AV)
- 206-0114-00 1 TIP, hook probe (CK)
- 344-0046-00 2 CLIP, alligator (AU)
- 352-0090-00 1 HOLDER, probe

Order P6048 10X Probe, 6 ft,
010-0215-00 \$175

Included Accessories with double alpha codes are pictured on pages 338 and 339.

P6056 Dc to 3.5 GHz 10X 50 Ω
P6057 Dc to 1.4 GHz 100X 5000 Ω

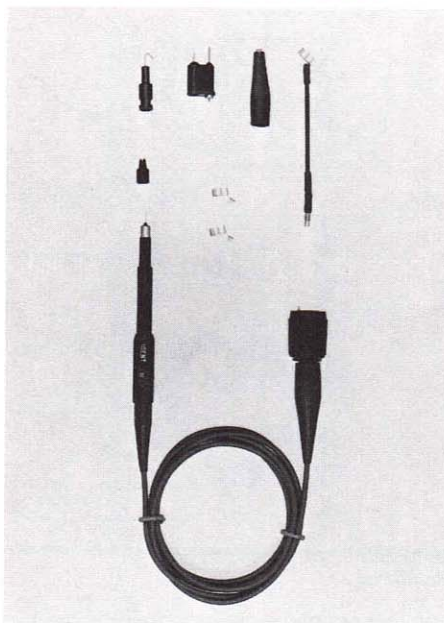

Low Capacitive Loading, 1 pF or Less

For 50 Ω Wide Band Scopes

<70 ps Probe to Probe Variation

The P6056 is a miniature low-capacitance probe for use with 50 Ω wide-band oscilloscopes. Bandwidth is dc to 3.5 GHz. This probe can also be used with 50 Ω sampling systems, with an appropriate BNC adapter. The P6056 is equipped with a special BNC connector that provides trace identification and CRT READOUT information when used with plug-in units and mainframes that have these features. A convenient button on the probe activates the trace identification function.

OTHER CHARACTERISTICS

| | P6056 | P6057 |
|------------------|-------------|-------------|
| Rise Time | <100 ps | <250 ps |
| Input Z @ 1 GHz | 300 Ω | 1500 Ω |
| Max Dc + Peak Ac | 16 V | 50 V |
| Derated Above | 800 MHz | 500 MHz |
| Max Peak @ 1 GHz | 9 V | 21 V |
| Max Peak Pulse | 500 V <1 ms | 500 V <1 ms |

INCLUDED ACCESSORIES

- 344-0046-00 1 CLIP, alligator (AU)
- 206-0114-00 1 TIP, hook probe (CK)
- 013-0085-00 1 TIP, probe bayonet (BM)
- 214-0283-00 1 CONTACT, electrical (CS)
- 175-0249-00 1 LEAD, ground, 7.5 cm (3 in) (AY)

ORDERING INFORMATION

P6056 10X, 50 Ω Probe, 6 ft.,
010-6056-03 \$140
 9 ft, 010-6056-05 \$140
P6057 100X, 50 Ω Probe, 6 ft.,
010-6057-03 \$145
 9 ft, 010-6057-05 \$145

P6046 Dc to 100 MHz

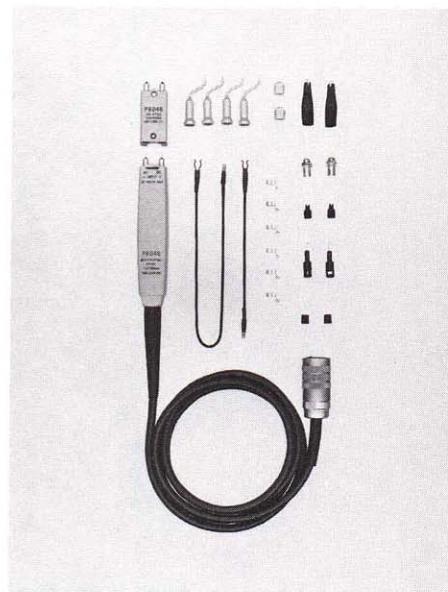

1000:1 Cmrr at 50 MHz

±250 V Maximum Voltage with 10X Attenuator

Dual Probe Tips for Greater Cmrr at High Frequencies

The P6046 Differential Probe and P6046 Amplifier Unit provide near measurement capabilities with all Tektronix Oscilloscopes. The differential-signal processing takes place in the probe itself, resulting in high common-mode signal rejection at higher frequencies. Differential probe-tip signal processing minimizes the measurement errors caused by differences in probes, cable lengths, and input attenuators.

CHARACTERISTICS

Cmrr — With deflection factors of 1 mV/div to 20 mV/div: at least 10,000:1 at 50 kHz, 5,000:1 at 1 MHz, and 1,000:1 at 50 MHz. **Common-mode Linear Dynamic Range** — ±5 V, ±50 V with 10X attenuator. **Bandwidth** — Dc to 100 MHz (–3 dB). **Rise Time** — 3.5 ns or less. **Deflection Factor Range** — 1 mV/div to 200 mV/div in 8 calibrated steps, 1-2-5 sequence, accurate within 3% (with an oscilloscope deflection factor of 10 mV/div). **Input RC** — 1 MΩ paralleled by 10 pF or less. **Input Coupling** — Ac or dc, selected by a switch on the probe. Low frequency response ac-coupled is –3 dB at 20 Hz, 2 Hz with 10X attenuator. **Displayed Noise** — 280 μV or less (tangentially measured). **Maximum Input Voltage** — ±25 V (dc + peak ac), ±250 V with 10X attenuation, derated with frequency. **Output Impedance** — 50 Ω through a BNC-connector. 50 Ω termination supplied with amplifier for use with 1 MΩ systems. **Probe Cable** — 6 ft long, terminated with special nine-pin connector. **Amplifier Power Requirements** — 10 W max, 48 to 400 Hz. Factory wired for 105 V to 125 V ac (117 V ac nominal) operation. Transformer taps permit operation at 210 V to 250 V ac (234 V ac nominal).

INCLUDED ACCESSORIES

- 014-0029-00 1 HANGER ASSEMBLY
- 012-0076-00 1 CABLE ASSY, RF (CW)
- 011-0049-01 1 TERMINATION, 50 Ω (BJ)
- 016-0111-01 1 CARRYING CASE

ORDERING INFORMATION

P6046 FET Differential Probe, Amplifier, and Power Supply 010-0232-00 \$1490
 W/o Amplifier and Power Supply, 010-0213-00 \$775
 Power Supply with Amplifier 015-0106-00 \$730

SUGGESTED MEASUREMENTS

X-ray Tube Currents

SCR Currents

Power Supply Currents

Motor Start-Up Currents

Industrial Control Currents

Relay Currents

Common-Mode Rejection of DC and AC Currents

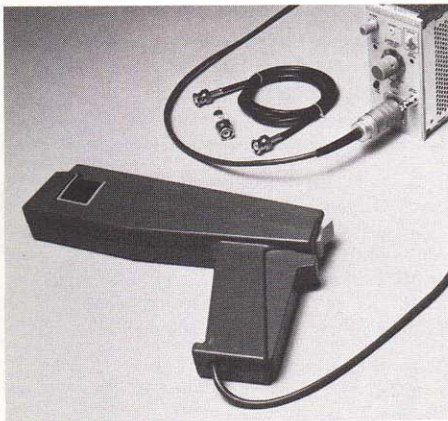

A6303 Current Probe

100 A Ac and Dc Current Measurements

Dc to 15 MHz Bandwidth

Peak Pulse Measurements to 500 A

Ac or Dc Coupling

1 inch x 0.830 inch (2.5 x 2.1 cm) Jaw Opening

Minimal Loading — 0.02 Ω Insertion Z at 1 MHz, 0.15 Ω at 15 MHz.

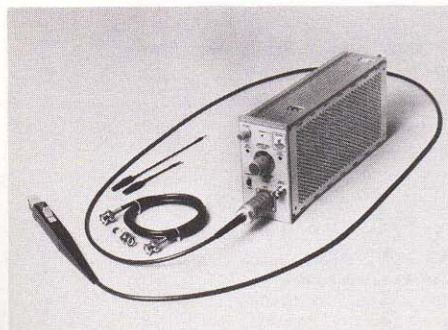

A6302 Current Probe

20 A Ac and Dc Current Measurements

Dc to 50 MHz Bandwidth

Peak Pulse Measurements to 50A, 50,000 A with the CT-5 Current Probe

Current Probe

Ac or Dc Coupling

Small Loading — 0.1 Ω Insertion Z at MHz, 0.5 Ω at 50 MHz.

A6303/A6302

The TEKTRONIX A6303 and A6302 are two current probes designed to be used with the AM 503 Current Probe Amplifier, any TM 500 Power Module and an oscilloscope.

Both probes make ac or dc coupled current measurements simply by opening their sliding jaws and placing them around the conductor being tested. With their combination ac and dc measurement capabilities, both can measure fast transients, low frequency response, and dc levels all at the same time. For differential or sum measurements, just place the conductors in the probe jaw in the proper phase.

The A6303, measures currents to 100A within the frequency range of dc to 15 MHz. It features a large 1 x 0.83 inch (2.5 x 2.1 cm) jaw opening to accommodate large cables. Peak pulse measurements may be made to 500 A.

The A6302 measures currents to 20 A, 50 A peak, within the frequency range of dc to 50 MHz. By adding the CT-5 Current Probe, you can extend the capabilities of the A6302 to a 5000 A/div range (50,000 A peak).

Both the A6303 and the A6302 are used for making SCR power supply, industrial control, and motor start-up current measurements. The A6303 is especially recommended for measuring the current in X-ray tubes to insure compliance with the performance standards of PL 90-602, the Radiation Control for Health and Safety Act of 1968. Both are valuable measurement tools when low loading is important, as when testing high impedance points, or with current dependent devices.

The A6303 or A6302 is connected to the AM 503 through a multi-pin connector. The AM 503 operates in any of the TM 500 Power Modules. It is calibrated in 12 steps; the knob skirt is illuminated to indicate current per division. Bandwidth can be limited to 5 MHz to eliminate unwanted transients. Both ac and dc coupling are provided. Ac coupling allows the measurement of low amplitude signals on a high-level dc current. A front-panel light warns of input currents above 100 A dc with the A6303 or 20 A dc with the A6302. A push button allows degaussing of probe when it is removed from the circuit and locked in operating position.

The output of the A6303/AM 503 can be displayed on any oscilloscope with at least a 50 MHz bandwidth and 10 mV sensitivity, the A6302/AM 503 on a 75 MHz oscilloscope with 10 mV sensitivity to display the probe's full bandpass. The AM 503 output can be plugged directly into a 50 Ω recording instrument, or a 50 Ω termination which is supplied.

A6303 CHARACTERISTICS

Bandwidth — Dc to ≥ 15 MHz (-3 dB), ≤ 7 Hz to ≥ 15 MHz (-3 dB) ac coupled. Bandwidth can be limited to ≈ 5 MHz with AM 503 front-panel switch.

Rise Time — 23 ns or less.

Maximum Current — 100 A (dc + peak ac).

Maximum Peak Pulse Current — 500 A. Not to exceed 10,000 A μ s.

Sensitivity — 10 mA/div to 50 A/div within 3%, (in calibrated steps) into 50 Ω load; indicating device (oscilloscope) sensitivity 10 mV/div.

Insertion Impedance — 0.02 Ω at 1 MHz, 0.15 Ω at 15 MHz.

Maximum Voltage (bare conductor) — 700 V.

Maximum Conductor Size — 0.830 inch (2.11 cm).

INCLUDED ACCESSORIES

016-0622-00 1 CARRYING CASE

A6302 CHARACTERISTICS

Bandwidth — Dc to ≥ 50 MHz (-3 dB), ≤ 7 Hz to >50 MHz (-3 dB) ac coupled; the system's bandwidth may be limited to ≈ 5 MHz with the AM 503 front panel switch.

Rise Time — 7 ns or less.

Maximum Current — 20A (dc + peak ac).

Maximum Peak Pulse Current — 50 A. Not to exceed 100 A μ s.

Sensitivity — 1 mA/div to 5 A/div within 3% (in calibrated steps) into a 50 Ω load; indicating device sensitivity 10 mV/div.

Insertion Impedance — 0.1 Ω at 5 MHz, 0.5 Ω at 50 MHz.

Maximum Voltage (bare conductor) — 500 V.

Maximum Conductor Size — 0.15 inch.

Cable Length — 2 meters.

Propagation Delay — ≈ 30 ns.

INCLUDED STANDARD ACCESSORIES

175-0124-01 1 LEAD, elec, probe ground, 13 cm (5 in) (AV)

175-0263-01 1 LEAD, elec, probe ground, 7.5 cm (3 in) (AV)

344-0046-00 2 CLIPS, miniature alligator (AU)

ORDERING INFORMATION

A6303 Current Probe,
010-6303-01 \$845

A6302 Current Probe,
010-6302-01 \$440

AM 503 Current Probe Amplifier
(See page 277) \$875

F-5010P3 System (includes assembled and tested A6303, AM 503 and TM 501) \$2100

F-5010P2 System (includes assembled and tested A6302, AM 503 and TM 501) \$1675

AM 503 INCLUDED STANDARD ACCESSORIES

012-0057-01 1 BNC CABLE, 50 Ω (CV)

011-0049-01 1 BNC TERMINATION, 50 Ω (BJ)

The AM 503 Current Probe Amplifier requires one of the TM 500 Series Power Modules listed below. The number of plug-ins the module will accept is designated by the last digit in the part number. The optional interface allows connections between plug-ins to be made through the rear panel of the power module. See page 296.

ORDERING INFORMATION

TM 501 Power Module \$285
With Opt 02 Interface Add \$55

TM 503 Power Module \$285
With Opt 02 Interface Add \$75

TM 504 Power Module \$315
With Opt 02 Interface Add \$100

TM 506 Power Module \$440
With Opt 02 Interface Add \$150

RTM 506 Power Module (rackmount version) \$560
With Opt 02 Interface Add \$150

TM 515 Traveler Mainframe \$545
With Opt 05 Interface Add \$75

With Opt 06 48-440 Hz Fan Add \$150

OPTIONAL ACCESSORIES

CT-5 Current Probe
Order 015-0189-01 \$980

CT-5 Opt 05 (w/o dc bucking coil)
Order 015-0189-00 \$800

See page 331 for more information.

P6021 w/Term

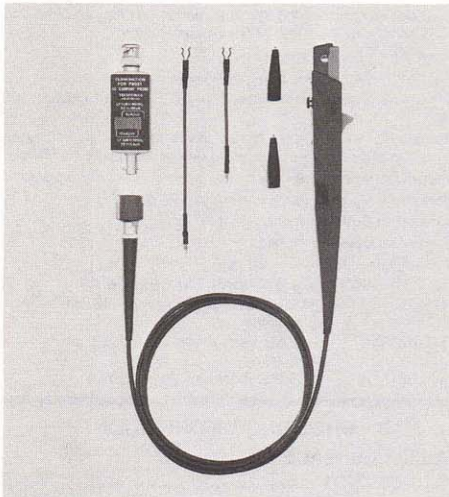

For General Purpose Applications

120 Hz to 60 MHz

Clip-on Probe

The individual units, P6021, 134, and P6022 provide designed for use with real time oscilloscopes. These various components can be assembled into a variety of performance packages.

P6021 w/134 P6021 w/term
P6022 w/134 P6022 w/term

The P6021 and P6022 are ac current probes designed for use with real time oscilloscopes. Either probe, with passive termination or with the amplifier, can be used with oscilloscopes having input resistance of 1 MΩ or greater. (Neither the termination nor the amplifier is required to use the P6021 Probe with the TEKTRONIX 5A21N Amplifier.) Both probes provide the facility for accurate current measurements over a wide range of frequencies without breaking the circuit under test.

P6022 w/Term

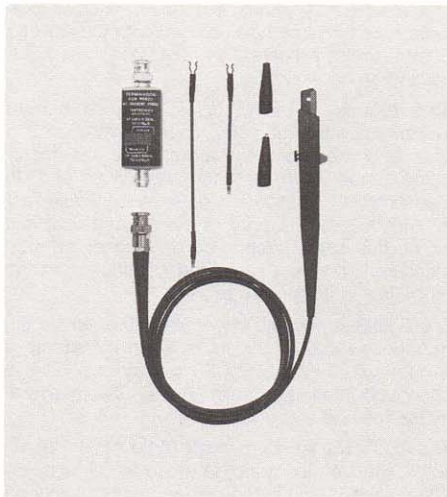

Small Size Suitable for Compact Circuitry

935 Hz to 200 MHz

Clip-on Probe

Just open the spring-loaded slide, place the conductor (up to 0.15 inch with P6021 and 0.1 inch with P6022) in the probe slot, and release the slide. No electrical connection is required.

The shielded probe head is not grounded when the slide is in the open position, eliminating accidental grounding of the circuit under the test.

For general purpose applications, the P6021 offers wide-band performance with excellent low-frequency characteristics. The extra-small size of the P6022 makes it ideally suited for measuring current in compact semiconductor circuits.

Both probes' low-frequency capabilities and sensitivity can be expanded using the 134 Current Probe Amplifier.

PERFORMANCE CHARACTERISTICS

| | Probe with Passive Termination | | Probe with 134 Amplifier |
|-------------------------------------|---|---|---|
| | P6021 | P6022 | |
| Sensitivity | 2 mA/mV or 10 mA/mV; selected by termination switch. Accuracy ± 3%. | 1 mA/mV or 10 mA/mV; selected by termination switch. Accuracy ± 3%. | 134 Amplifier switchable in steps from 1 mA/div to 1 A/div (with 50 mV/div oscilloscope setting. Accuracy ± 3%. |
| Bandwidth† | 2 mA/mV ≤ 450 Hz to 60 MHz 10 mA/mV ≤ 120 Hz to 60 MHz | 1 mA/mV — ≤ 8.5 kHz to 130 MHz 10 mA/mV — ≤ 935 Hz to 200 MHz | 12 Hz to 38 MHz |
| Probe Only* | | | 100 Hz to 65 MHz |
| Max Current (CW) | P6021 15 A p-p sinewave between 1.2 kHz and 5 MHz at 2 mA/mV; between 300 Hz and 5 MHz at 10 mA/mV. | P6022 6 A p-p sinewave between 10 kHz and 10 MHz at 1 mA/mV; between 3 kHz and 10 MHz at 10 mA/mV | 15 A p-p sinewave between 230 Hz and 5 MHz 6 A p-p sinewave between 1.3 kHz and 10 MHz 1.3 kHz and 10 MHz |
| Max Current | P6021 250 A peak, not to exceed 500 A-μs | P6022 100 A peak, not to exceed 9 A-μs 0.5 A | 15 A peak, not to exceed 500 A-μs 15 A peak, not to exceed 9 A-μs |
| Max dc | | | ≤ 150 μA |
| Noise | | | 600 V (dc + peak ac) |
| Max Voltage (bare conductor) | | | ≈ 5 lb |
| Net Weight | | | |

†All bandwidths stated are -3dB

*To estimate the scope/probe system bandwidth from the probe only bandwidth, use the relationship

$$(t_{system})^2 = (t_{scope})^2 + t_p^2 \times BW = 0.35$$

134 Current Probe Amplifier

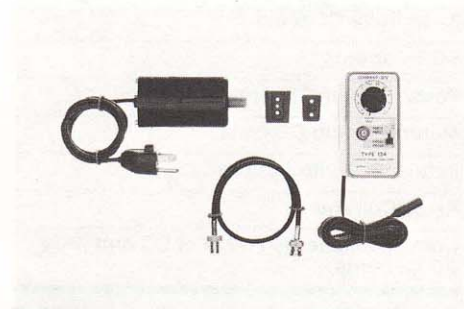

Use to Expand the Low Frequency Capability and Sensitivity of Either Probe

The 134 is used to extend the measurement capabilities of the P6021 or P6022 Current Probe. A CURRENT/DIV switch provides calibrated current steps from 1 mA/div to 1 A/div (with the oscilloscope or plug-in unit adjusted for a deflection factor of 50 mV/div). A passive termination is not required when using a 134 and a P6021 or P6022.

The 134 can also be used as an auxiliary voltage amplifier by placing the CURRENT/DIV switch in the VOLTS position.

INCLUDED ACCESSORIES (P6021 and P6022)

175-0125-01 1 LEAD, ground, 13 cm (5 in) (AW)
175-0263-01 1 LEAD, ground, 7.5 cm (3 in) (AV)
344-0046-00 2 CLIP, alligator (AU)

ORDERING INFORMATION P6021

P6021 Current Probe and Term, 5 ft,
015-0140-02 \$295
9 ft and Term, 015-0140-03 \$295
5 ft w/o Term, 010-0237-02 \$250
9 ft w/o Term,
010-0244-02 \$250

P6022

P6022 Current Probe and Term, 5 ft.
015-0135-00 \$325
9 ft and Term, 015-0135-01 \$325
5 ft w/o Term, 010-0238-00 \$255
9 ft w/o Term,
010-0238-02 \$255

134

134 Current Probe Amplifier,
015-0057-02 \$540
Included Accessories:
014-0029-00 1 HANGER assembly
012-0104-00 1 CABLE assembly (CX)
015-0058-01 1 POWER SUPPLY, 110 V
Opt 04,230 V ac, 015-0057-03 \$540
Included Accessories: Same as above, but with 230 V power supply (015-0059-01).

OPTIONAL ACCESSORIES

for P6021, P6022, and 134
Calibrator Adapter, BNC, Order 013-0092-00 \$33
Carrying Case for P6021 or P6022, and a 134
Amplifier, Order 016-0087-01 \$23
Passive Termination
For P6021, Order 011-0105-00 \$105
For P6022, Order 011-0106-00 \$115

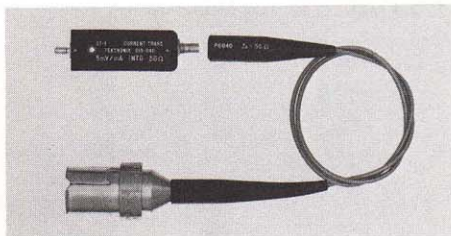

CT-1
1 GHz Ac Current Probe for 50 Ω Systems

Used with 50 Ω Systems, or Wide Band Non-sampling Oscilloscopes Using a 50 Ω Term

CT-1 Permanently Inserted in 50 Ω Circuit Has Minimum Effect on the 50 Ω Environment

Probe Cable

The 010-0133-00 probe cable is an interconnecting cable for the CT-1, used between the transformer and oscilloscope input. If several CT-1 Transformers are in a circuit, the probe cable can be used to monitor any one of them.

The probe cable can be used with other test-point connectors, such as Amphenol Series 27 Sub-Minax or Sealectro Sub-Miniature RF.

CHARACTERISTICS

Sensitivity — 5 mV/mA within ±3% into a 50 Ω load. **Decay Time Constant** — 6.35 μs, ≈ by 1% per 50 ns; limit, 1 μs. **Rise Time** — less than 350 ps. **Frequency Response** — 25 kHz to 1 GHz (–3 dB). **Insertion Impedance** — 1 Ω shunted by ≈ 6 μH with a 50 Ω termination; 2 Ω shunted by ≈ 5 μH without a 50 Ω termination. **Capacitance Loading** — Typically 1.5 pF for bare #14 gauge wire passing through the CT-1 transformer; 0.6 pF for #20 gauge. **Maximum Voltage of Circuit Under Test** — 1000 V (dc plus peak ac) **Direct Current** — Reduces the L/R time constant by a factor of 2 at 75 mA. **Pulse Current Rating** — 12 A peak, with a 50 Ω load, with a maximum amp-second product of 1 A μs. **RMS Current Rating** — 450 mA maximum with a 50 Ω load. **Temperature Rating** — 25°C to ±65°C. **Transformer Physical Dimensions** — 3/8 x 9/16 x 1-13/16 in; #6-32 x 1/4 in mounting stud. **Probe Cable Impedance** — 50 Ω. **Probe Cable Attenuation** — 1X. **Cable Length** — 18 in. **Output Connector** — GR type.

ORDERING INFORMATION

| | |
|--|--------------|
| CT-1 Current Transformer and Probe, 015-0041-00 | \$130 |
| CT-1 Current Transformer (without Probe), 015-0040-00 | \$78 |
| Probe Cable, 010-0133-00 | \$63 |

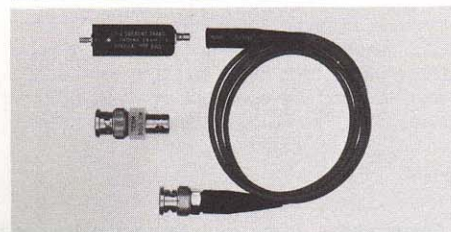

CT-2
100 MHz Ac Current Probe

Use with Oscilloscopes up to 100 MHz BW Insulated Case for Limited Space Applications

Several CT-2 Transformers Can Be Used in the Circuit and Monitored by One Cable

Probe Cable

The 010-0164-00 probe cable connects the CT-2 Transformer and the oscilloscope input. A 50 Ω termination is used with the probe cable for terminating the probe cable at the high impedance input of the oscilloscope.

CHARACTERISTICS

Sensitivity — 1 mV/mA within 3% into a 50 Ω load. **Decay Time Constant** — 160 μs, ≈ by 1% per 1.25 μs; limit, 25 μs. **Rise Time** — 0.5 ns. **Frequency Response** — up to 100 MHz; –3 dB at 1.2 kHz, –3 dB at 200 MHz. **Insertion Impedance** — 0.04 Ω shunted by ≈ 7 mH in series with 0.9 mH with a 50 Ω termination; 0.08 Ω shunted by ≈ 7 mH in series with 0.9 mH without a 50 Ω termination. **Capacitance Loading** — Typically 1.8 pF for a bare #16 gauge wire passing through the CT-2 transformer; 0.7 pF for a #22 gauge wire. **Maximum Voltage of Circuit Under Test** — 1000 V (dc + peak ac). **Direct Current** — Reduces the L/R time constant by a factor of 2 at 175 mA. **Pulse Current Rating** — 36 A peak, with a maximum amp-second product of 50 A μs. **RMS Current Rating** — 1.25 A maximum. **Temperature Rating** — 25°C to +65°C. **Transformer Physical Dimensions** — Same as CT-1. **Probe Cable Impedance** — 50 Ω. **Probe Cable Attenuation** — 1X. **Cable Length** — 42 in. **Output Connector** — BNC type.

Included Accessories:

| | |
|-------------|--------------------------|
| 010-0164-00 | 1 CABLE, probe |
| 011-0049-01 | 1 TERMINATION, 50 Ω (BJ) |

ORDERING INFORMATION

| | |
|--|--------------|
| CT-2 Plus Cable and Term, 015-0047-00 | \$140 |
| w/o Cable or Term, 015-0046-00 | \$85 |
| Probe Cable, (010-0164-00) | \$48 |

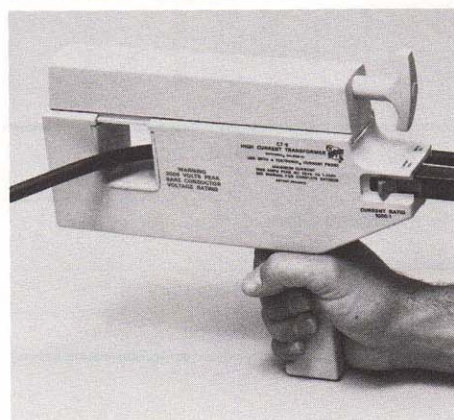

CT-5
Pulsed Currents to 50,000 A

20 mA per Division Sensitivity

1.5 Inch Diameter Conductors

Measurements on Bare Conductors to 3000 V Nullifies Dc Effects to 300 A

The CT-5 is a clip-on high-current transformer which extends the measurement capability of Tektronix Clip-on Current Probes. Maximum low-frequency performance is obtained using the A6302/AM 503 Dc Current Probe. Pulse current to 50,000 A may be measured using the P6021 and passive termination, provided the 0.5 A-s rating

is not exceeded. The P6021 and 134 Current Probe Amplifier may also be used for measurements at normal power line frequency and above. (The P6022 and CT-5 are not compatible with each other.) The CT-5 has receptacles for current probes in either 20:1 or 1000:1 step-down ratios. The 1.5 inch square opening makes it possible to clip onto large conductors without breaking the circuit under test. The core and shield assembly is insulated from the windings and the handle. This allows measurements on bare conductors to 3000 V, and to 10 kV RMS when using high voltage bushing.

Use of dc bucking coil assembly allows up to 300 A of dc to be tolerated without appreciably degrading the measurements. This is very useful for measuring ac signals riding on top of dc.

CT-5 CHARACTERISTICS

The following are characteristics of the CT-5 using either the A6302/AM 503 or P6021/134 combinations.

Rise Time is 17.5 ns or less. **Insertion Impedance** is 20 μΩ or less at 60 Hz, increasing to 20 mΩ at 1 MHz. **Current Range** is 20 mA/div to 100 A/div with A6302/AM 503, and 20 mA/div to 20 A/div with P6021/134 (20:1 step down ratio); 1 A/div to 5 kA/div with A6302/AM 503, 1 A/div to 1 kA/div with P6021/134, (1000:1 step down ratio). **Accuracy** is ±4%. **Max Current** is 1000 A peak cw.* **Amp-Sec product** is 8 A-s. **Max Voltage** of circuit test is 3000 V (bare conductor). **Max Dc Bucking Current** is 300 mA to buck out 300 A dc (using dc bucking coil). **Dimensions and weight** — the length is 10.5 in, width is 2.25 in, height is 9.5 in, net weight is ≈ 4 lb.

* Max current 1,000 A peak from 20 Hz to 1.2 kHz derating to 100 A peak at 1 MHz.

Included Accessories:

| | |
|-------------|--------------------------------|
| 016-0191-03 | 1 CARRYING CASE |
| 015-0194-00 | 1 BUSHING, high voltage, 12 in |

ORDERING INFORMATION

CT-5 Current Probe (includes Dc Bucking Coil) 015-0189-01

| | |
|--|-------|
| \$980 | |
| w/o Dc Bucking Coil, 015-0189-00 | \$800 |

OPTIONAL ACCESSORIES

| | |
|--|-------|
| Dc Bucking coil, 015-0190-00 | \$240 |
| High-Voltage Bushing, 4 ft long, inside diameter 1 in, 015-0194-01 | \$40 |

CT-3 SIGNAL PICKOFF

Designed for use with high-frequency oscilloscopes, the CT-3 Pickoff provides a convenient means of picking off a signal in a 50 Ω system. Used with any of the Tektronix sampling instruments, the CT-3 provides the link for use as a trigger source.

Sensitivity is 10% of the voltage under test, into a 50 Ω load. **Decay Time Constant** is 4.5 μs at 0 dc current. **Rise Time** is less than 0.4 ns. **Frequency Response** is 50 kHz to 875 MHz at 0 dc current. **Insertion Impedance** with 50 Ω termination is 1 Ω shunted by 4.5 μH, 2Ω shunted by 4.5 μH without a 50 M termination. **Vswr** is less than 1.2 at 1.5 GHz. **Voltage Rating** at 0 V dc is 25 V RMS, 1 kV pulse peak. The Vs product is 100 Vμs. If exceeded, the L/R decay will decay rapidly toward zero.

CT-3 Signal Pickoff, Order 017-0061-00

CT-5 CURRENT MEASUREMENT COMBINATIONS

| Product | Current Div Scope Set | | Bandwidth | A-s Product | Max Current | |
|-------------------|-----------------------|---------------|------------------|-------------|-------------|------------|
| | 10 mV/div | 50 mV/div | | | RMS | Peak Pulse |
| CT-5/A6302/AM 503 | 20 mA to 5 kA | | 0.5 Hz to 20 MHz | 0.1 | 700 A | 50 kA |
| CT-5/P6021/134 | | 20 mA to 1 kA | 12 Hz to 20 MHz | 0.5 | 700 A | 15 kA |
| CT-5/P6021/Term | 400 mA to 100 A | 2A to 500 A | 120 Hz to 20 MHz | 0.5 | 700 A | 50 kA |

NEW P6120 Dc to 60 MHz

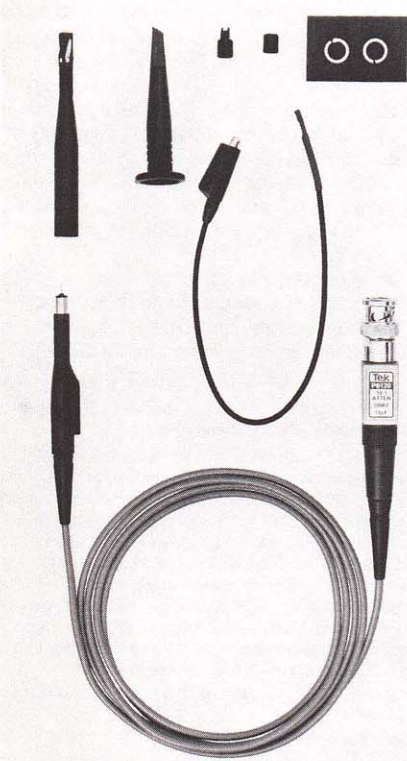

500 V Maximum Voltage

Modular, Snap-Together Parts

Low Cost

The P6120 miniature 10X passive probe, a continuation of the modular design concept, offers good performance at a very attractive price. It performs particularly well in combination with 2200-Series Oscilloscopes. The probe is designed to be repairable and employs a replaceable compensation box, cable, and probe head, with the ground attached by a shielded-pin receptacle in the probe head. User comfort and safety are enhanced by the probe head shape. Two cable lengths are available: 1.5 and 3.0 meters. All modular probe accessories fit the P6120.

The probe is also designed to allow use of the optional push on/pull off IC Grabber Tip that greatly facilitates attachment in congested circuit areas such as DIP leads and multi-pin connectors.

CHARACTERISTICS

Bandwidth — Dc to 60 MHz (–3dB). **Rise Time** — <5.9 ns. **Attenuation (System)** — 10X ±2% (with oscilloscope resistance of 1 MΩ ±1%). **Input Resistance (Probe)** — 9.0 MΩ ±1% series resistor. **Input Resistance (System)** — 10 MΩ ±1%. **Input Capacitance** — 14 pF with 1.5 meter cable, 17 pF with 3.0 meter cable. **Maximum Input Voltage (Ac/Dc Coupled)** — 500 V (dc + peak ac) to 3 MHz, derated to 70 V (dc + peak ac) at 50 MHz. **Compensation Range** — 23 pF to 51 pF.

INCLUDED ACCESSORIES

- 016-0521-00 1 POUCH, Accessory (not shown)
- 013-0107-04 1 TIP, Retractable (BS)
- 166-0404-01 1 SLEEVE, Insulating (CH)
- 334-2794-02 2 BAND, Marker (Silver-Gray) (not shown)
- 195-0950-00 1 GROUND LEAD, 25-cm (10-in)

ORDERING INFORMATION

P6120 10X Voltage Probe and Accessories:

1.5-meter cable 010-6120-01 \$75.

Optional Tip, Probe with Actuator (IC Grabber):

013-0191-00 \$10

P6101 Dc to 34 MHz 1X

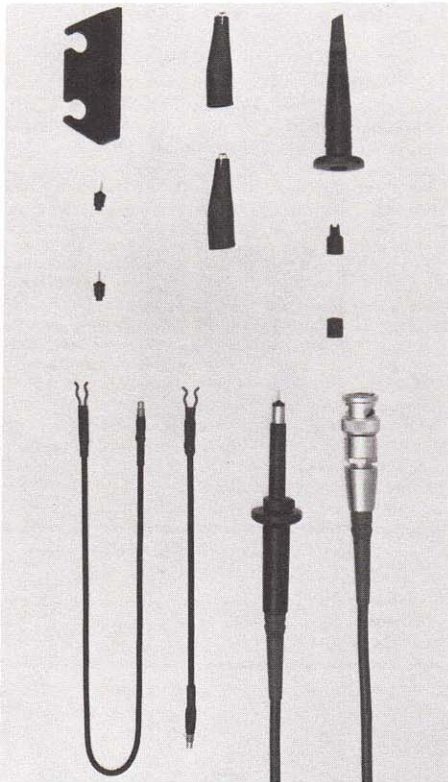

Simplified, Faster Maintenance and Repairs

High Fidelity Signal Acquisition at Low Cost

Rugged for Greater Reliability

Available in Three Lengths

Modular parts snap together

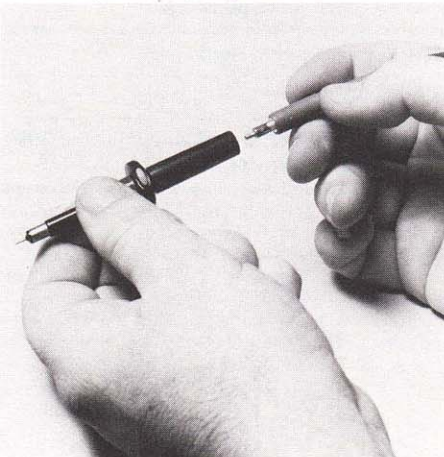

P6105 Dc to 100 MHz 10X with Readout P6108 Dc to 100 MHz 10X

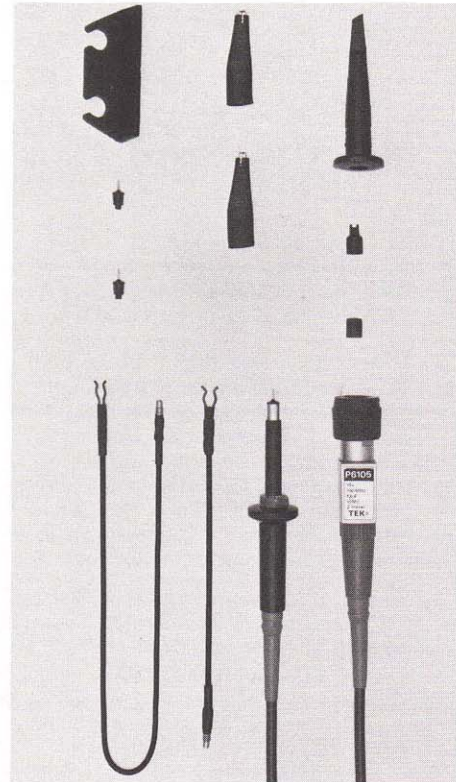

Modular probes are an exciting new concept in probe design. The P6101, P6105, P6106, P6107, P6108, P6120 and P6149 Probes divide into three modules (probe heads, cables, and connector/compensation boxes). The modules snap together making maintenance and repair less expensive, faster, and much easier. Snap-on replacement modules eliminate soldering irons and tools, and modular probes do not have to be sent in to be repaired because spare modules can be ordered and stocked. Strain relief and modular component design make these probes rugged for greater reliability.

The P6101, P6105, P6106, and P6108 are available in three color-coded lengths — blue for one meter, yellow for two meters, and red for three meters. (The P6149 and P6107 are two meters long.) These probes may be used to acquire high fidelity signal from low source-impedance circuits.

Tektronix Modular Probes are designed for specific Tektronix Instruments, but may be purchased as options for all Tektronix Oscilloscopes with 1 MΩ and appropriate pF inputs as indicated in the chart. The P6106 is standard with the 475A and 475 oscilloscopes.

For modular probe replacement parts, see page 338.

P6106 Dc to 300 MHz 10X with readout

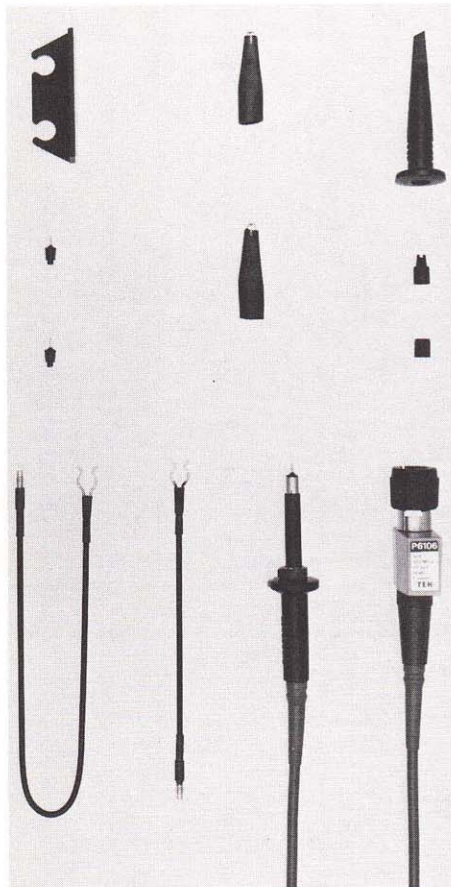

P6107 Dc to 100 MHz 10X

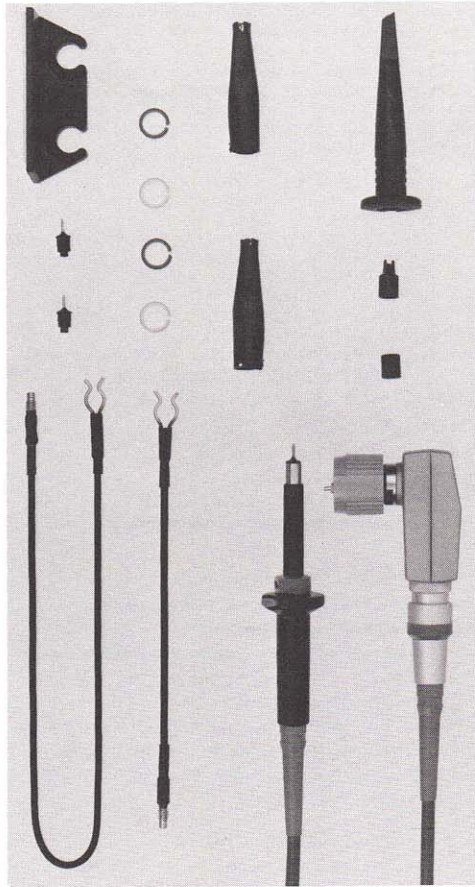

P6149 Dc to 50 MHz 10X with readout

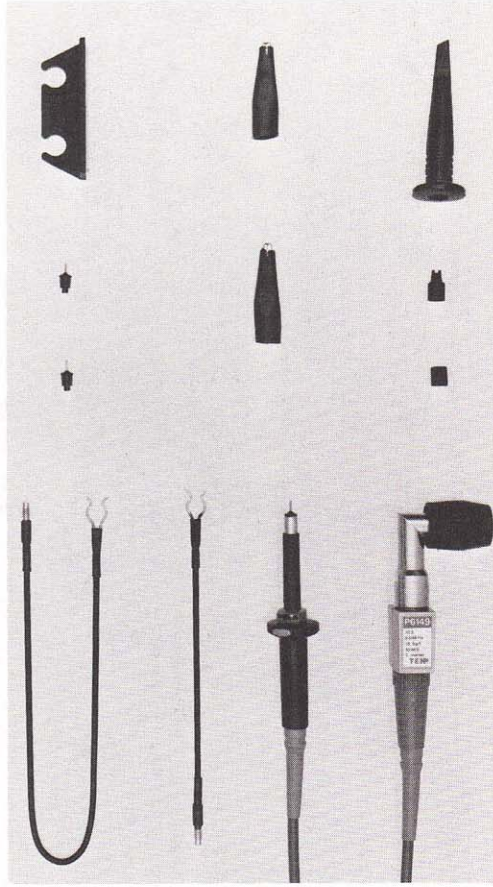

The P6105 is standard with the TEKTRONIX 434, 455, 465B, and rackmount oscilloscopes. And the P6108 is standard with the T932A and T935A oscilloscopes.

The P6101 is a 1X, 1 MΩ probe. The P6105, P6106, P6107, and P6108 are 10X, 10 MΩ probes.

With oscilloscopes that are equipped with vertical scale or CRT readout, the P6105 and P6106 will automatically scale the readout by a factor of 10. This makes mental calculations unnecessary. Also ground level can be determined on the display by actuating a button on the probe head, without having to return to the oscilloscope.

INCLUDED ACCESSORIES

- All probes, except as noted
- 013-0107-03 1 TIP, retractable hook (BS)
 - 166-0404-01 1 SLEEVE, insulating (CH)
 - 175-0124-01 1 LEAD, ground, 13 cm (AW)
 - 175-0125-01 1 LEAD, ground, 30 cm (AX)
 - 175-0263-01 1 LEAD, ground, 7.5 cm P6106 only (AV)
 - 2 TIPS, probe
 - 3 PR. MARKER BANDS, (black, white, and silver gray) All except P6149 (not shown)
 - 2 PR. MARKER BANDS, (gray, and silver gray) P6149 (not shown)
 - 344-0046-00 2 CLIPS, miniature, alligator (AU)
 - 352-0351-00 1 PROBE HOLDER
 - 016-0521-00 1 POUCH, accessory (not shown)
- **Available in packages of 10 only, 206-0191-03. (CM)
*Available in packages of 9 sets of different colors—016-0633-00.

The P6149 features a right angle BNC connector. This can be useful when bench space is limited.

ORDERING INFORMATION

| | | |
|-------------------------------|--|-------|
| P6101, 1X Probe, 2 m, | | |
| 010-6101-03 | | \$60 |
| 1 m, 010-6101-01 | | \$60 |
| 3 m, 010-6101-05 | | \$60 |
| P6105, 10X Probe, 2m, | | |
| 010-6105-03 | | \$100 |
| 1 m, 010-6105-01 | | \$100 |
| 3 m, 010-6105-05 | | \$100 |
| P6106, 10X Probe, 2 m, | | |
| 010-6106-03 | | \$124 |
| 1 m, 010-6106-01 | | \$124 |
| 3 m, 010-6106-05 | | \$124 |
| P6107, 10X Probe, 2 m, | | |
| 010-6107-03 | | \$105 |
| P6108, 10X Probe, 2 m, | | |
| 010-6108-03 | | \$90 |
| 1 m, 010-6108-01 | | \$90 |
| 3 m, 010-6108-05 | | \$90 |
| P6149, 10X Probe, 2 m, | | |
| 010-6149-03 | | \$95 |

CHARACTERISTICS

| Type | Attenuation | Length | Package Number | Loading | Useful BW MHz | Dc Max | Scope in pF | Readout |
|-------|-------------|--------|----------------|---------------|------------------|--------------------|-------------|---------|
| P6101 | 1X | 1 m | 010-6101-01 | 1 MΩ 32 pF | 34 | 500 V ¹ | ANY | — |
| | | 2 m | 010-6101-03 | 54 pF | 15.5 | | | |
| | | 3 m | 010-6101-05 | 78 pF | 8 | | | |
| P6105 | 10X | 1 m | 010-6105-01 | 10 MΩ 10.5 pF | 100 | 500 V ³ | 15 to 47 | YES |
| | | 2 m | 010-6105-03 | 13.0 pF | 100 | | | |
| | | 3 m | 010-6105-05 | 15.5 pF | 95 | | | |
| P6106 | 10X | 1 m | 010-6106-01 | 10 MΩ 10.5 pF | 300 ⁵ | 500 V ⁴ | 15 to 24 | YES |
| | | 2 m | 010-6106-03 | 13.0 pF | 250 | | | |
| | | 3 m | 010-6106-05 | 15.5 pF | 150 | | | |
| P6107 | 10X | 2 m | 010-6107-03 | 10 MΩ 13.0 pF | 100 | 500 V ³ | 14 to 47 | YES |
| P6108 | 10X | 1 m | 010-6108-01 | 10 MΩ 10.5 pF | 100 | 500 V ³ | 15 to 47 | NO |
| | | 2 m | 010-6108-03 | 13.0 pF | 100 | | | |
| | | 3 m | 010-6108-05 | 15.5 pF | 95 | | | |
| P6149 | 10X | 2 m | 010-6149-03 | 10 MΩ 15.5 pF | 50 | 500 V ³ | 20 to 62 | NO |

¹Max Input Voltage is 500 V dc + peak ac to 300 kHz derated to 20 V at 30 MHz.
²Max Input Voltage is 500 V dc + peak ac to 1.7 MHz derated to 27 V at 100 MHz.
³Max Input Voltage is 500 V dc + peak ac to 1.7 MHz derated to 30 V at 50 MHz.
⁴Max Input Voltage is 500 V dc + peak ac to 1.7 MHz derated to 70 V at 100 MHz.
⁵Scope bandwidth must be 325 MHz.

Included Accessories with double alpha codes are pictured on pages 338 and 339.

P6006 and P6007 Probes

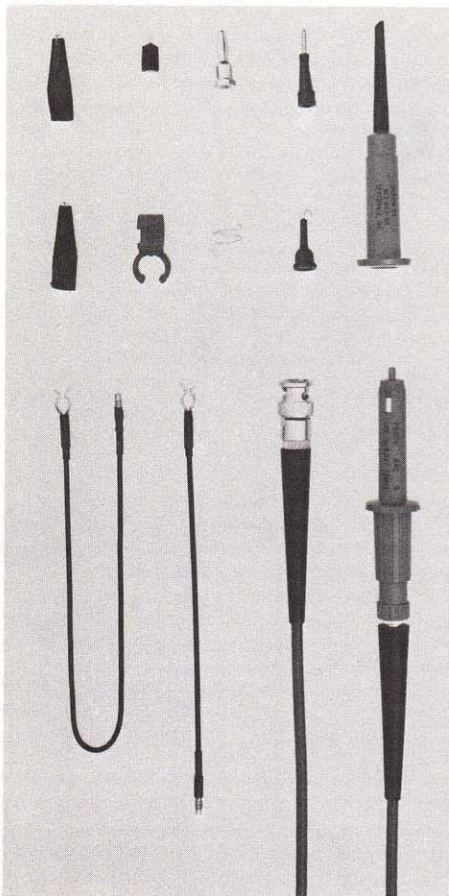

P6006 Dc to 35 MHz 10X

Low Cost

The P6006 is a general-purpose probe. It can be compensated to match all Tektronix Plug-ins and Oscilloscopes with nominal input capacitances of 15 pF to 55 pF and input resistance of 1 MΩ. This probe is more rugged and has a higher voltage rating than the miniature probes.

CHARACTERISTICS

Attenuation — 10X. **Input Resistance** — 10 MΩ. **Input Capacitance** — 7.5 pF for 3.5 ft probe cable when used with an instrument having 20 pF input capacitance; 8.5 pF for 6 ft version; 11 pF for 9 ft version; 13 pF for 12 ft version. **Bandwidth** — Dc to 35 MHz for 3.5 ft version. **Voltage Rating** — 600 V dc, as peak or dc and ac peak combined. P-p voltage derating is necessary for cw frequencies higher than 5.7 MHz when working into a 20 pF input, or higher than 3.6 MHz when working into a 47 pF input.

INCLUDED ACCESSORIES

| | |
|-------------|-------------------------------------|
| 013-0071-00 | 1 TIP, probe, retractable hook (AD) |
| 134-0013-00 | 1 PLUG, tip, bana (AF) |
| 175-0124-01 | 1 LEAD, ground, 13 cm (5 in) (AW) |
| 175-0125-01 | 1 LEAD, ground, 30 cm (12 in) (AX) |
| 206-0015-00 | 1 TIP, probe (0.055 in dia) (AH) |
| 206-0105-00 | 1 TIP, probe, hook (AM) |
| 344-0046-00 | 2 CLIP, alligator (AU) |
| 352-0090-00 | 1 HOLDER, probe |

ORDERING INFORMATION

| | |
|-------------------------------|-------------|
| P6006 10X Probe, 6 ft, | |
| 010-0160-00 | \$80 |
| 3.5 ft BNC, 010-0127-00 | \$80 |
| 9 ft BNC, 010-0146-00 | \$80 |
| 12 ft BNC, 010-0148-00 | \$80 |

P6007 Dc to 25 MHz 100X

Low Capacitance Loading

The P6007 is a low input capacitance, high-voltage (1.5 kV) probe. It can be compensated to match all Tektronix Plug-ins and Oscilloscopes with nominal input capacitances of 15 pF to 55 pF and input resistance of 1 MΩ. The P6007 is similar to the photo of the P6006.

CHARACTERISTICS

Attenuation — 100X. **Input Resistance** — 10 MΩ. **Input Capacitance** — 2.0 pF for 3.5 ft probe cable when used with an instrument having 20 pF input capacitance; 2.2 pF for the 6 ft version; 2.4 pF for the 9 ft version; 2.6 pF for the 12 ft version. **Bandwidth** — Dc to 25 MHz. **Voltage Rating** — 1.5 kV dc or ac RMS, 4.2 kV as p-p. P-p voltage derating is necessary for cw frequencies higher than 200 kHz. At 20 MHz, the maximum allowable p-p voltage is 2 kV. Above 10 MHz, additional derating is required depending on the input capacitance of the instrument used.

INCLUDED ACCESSORIES

Same as for P6006.

ORDERING INFORMATION

| | |
|--------------------------------|-------------|
| P6007 100X Probe, 6 ft, | |
| 010-0165-00 | \$95 |
| 3.5 ft, 010-0150-00 | \$95 |
| 9 ft, 010-0152-00 | \$95 |
| 12 ft, 010-0154-00 | \$95 |

P6008 Probes

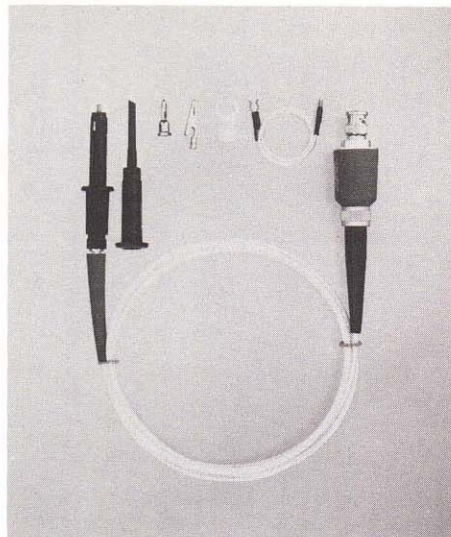

P6008(Environmental) 10X 100 MHz

—50°C to +150°C

The P6008 Environmental Probe is designed to operate over —50°C to +150°C for the probe body and cable; the compensation box operates from —15°C to +55°C. It is designed for use with Tektronix dc to 100 MHz Oscilloscopes. The probe can be compensated to match Tektronix Plug-ins and Oscilloscopes with nominal input capacitance of 12 pF to 47 pF and input resistance to 1 MΩ.

CHARACTERISTICS

Attenuation — 10X. **Input Resistance** — 10 MΩ. **Input Capacitance** — ≈ 7.5pF when used with an instrument having a 20 pF input capacitance. **Bandwidth** — Dc to 100 MHz. **Voltage Rating** — 600 V dc, ac peak, or dc and ac peak combined. P-p voltage derating is necessary for cw frequencies higher than 20 MHz. At 40 MHz, the maximum allowable p-p voltage is 300 V.

INCLUDED ACCESSORIES

| | |
|-------------|-------------------------------------|
| 134-0013-00 | 1 PLUG, tip, banana (AF) |
| 344-0045-00 | 1 CLIP, alligator (AT) |
| 175-0525-00 | 1 LEAD, ground, 30 cm (12 in)(BD) |
| 352-0090-00 | 1 TIP, probe, retractable hook (AE) |

Order P6008 Environmental 10X Probe, 6 ft, 010-0129-01 **\$195**

P6008 (Non-Environmental) 10X 100 MHz

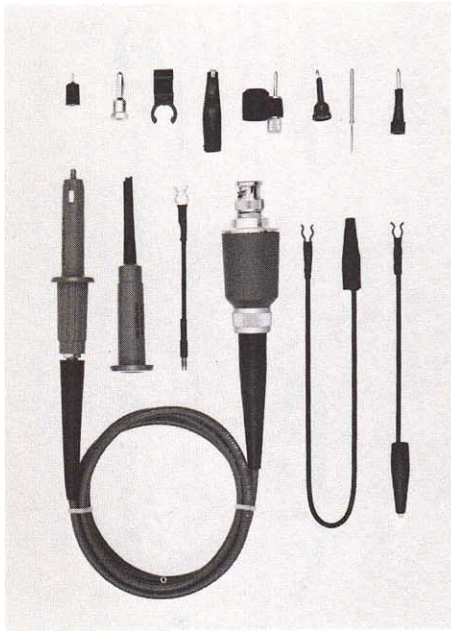

Low Capacitance

The **P6008** Non-Environmental Probe is designed for use with Tektronix dc to 100 MHz Oscilloscopes. This 10X attenuation probe can be compensated to match plug-ins and oscilloscopes with input capacitances of 8 pF to 50 pF and input resistance of 1 MΩ.

The P6008 (Non-Environmental) is similar to the photo of the P6008 (Environmental).

CHARACTERISTICS

Attenuation — 10X. **Input Resistance** — 10 MΩ. **Input Capacitance** — ≈ 7.5 pF when used with an instrument having a 20 pF input capacitance. **Bandwidth** — Dc to 100 MHz. **Voltage Rating** — 600 V dc, ac peak, or dc and ac peak combined. P-p voltage derating is necessary for cw frequencies higher than 20 MHz. At 40 MHz, the maximum allowable p-p voltage is 300 V.

INCLUDED ACCESSORIES

- 134-0013-00 1 PLUG, tip, banana (AF)
- 344-0046-00 1 CLIP, alligator (AU)
- 175-0125-01 1 LEAD, ground, 30 cm (12 in) (AX)
- 175-0124-01 1 LEAD, ground, 13 cm (5 in) (AW)
- 175-0263-01 1 LEAD, ground, 7.5 cm (3 in) (AV)
- 352-0068-00 1 HOLDER, probe
- 013-0071-00 1 TIP, probe, retractable hook (AD)
- 206-0060-00 1 TIP, probe, (0.080 in dia) (AI)
- 206-0105-00 1 TIP, probe, hook (AM)
- 206-0015-00 1 TIP, probe, (0.055 in dia) (AH)
- 013-0052-00 1 TIP, probe, retractable hook (AA)

Order P6008 Non-Environmental 10X Probe, 3.5 ft,

010-0129-01 \$195

P6009 Dc to 120 MHz 100X

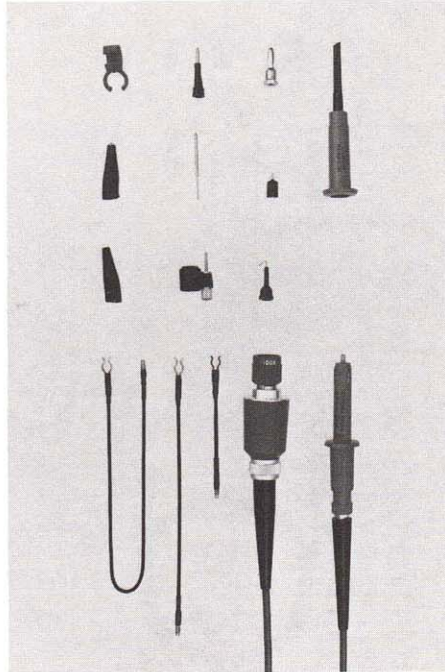

Dc to 120 MHz

Low Capacitance — 2.5 pF

100X Attenuation

The P6009 is a low input capacitance, high-voltage (1.5 kV) probe designed for use with Tektronix dc to 150 MHz Oscilloscopes. The probe can be compensated to match Tektronix Plug-ins and Oscilloscopes with nominal input capacitances of 12 pF to 47 pF and input resistance of 1 MΩ.

A version of the P6009 is equipped with a special BNC connector that provides CRT READOUT information when used with plug-in units and mainframes that have these features. The readout connector is not compatible with most standard non-readout BNC connectors.

CHARACTERISTICS

Attenuation — 100x. **Input Resistance** — 10 MΩ. **Input Capacitance** — ≈ 2.5 pF when used with instrument having 20 pF input capacitance. **Bandwidth** — Dc to 120 MHz. **Voltage Rating** — 1.5 kV dc or ac RMS, 4 kV ac p-p. P-p voltage derating is necessary for cw frequencies higher than 200 kHz. At 40 MHz, the maximum allowable p-p voltage is 425 V.

INCLUDED ACCESSORIES

- 175-0125-01 1 LEAD, ground, 30 cm (12 in) (AX)
- 175-0124-01 1 LEAD, ground, 13 cm (5 in) (AW)
- 175-0263-01 1 LEAD, ground, 7.5 cm (3 in) (AV)
- 013-0071-00 1 TIP, probe, retractable hook (AD)
- 013-0052-00 1 TIP, probe, retractable hook (AA)
- 344-0046-00 2 CLIP, alligator (AU)
- 206-0060-00 1 TIP, probe, (0.080 in dia) (AI)
- 206-0105-00 1 TIP, probe, hook (AM)
- 134-0013-00 1 PLUG, tip, banana (AF)
- 206-0015-00 1 TIP, probe (0.055 in dia) (AH)
- 352-0090-00 1 HOLDER, probe

Order P6009 100X Probe, 9 ft, w/Readout,

010-0264-01 \$150

w/o Readout,

010-0170-00 \$150

Included Accessories with double alpha codes are pictured on pages 338 and 339

P6015 40 kV 1000X

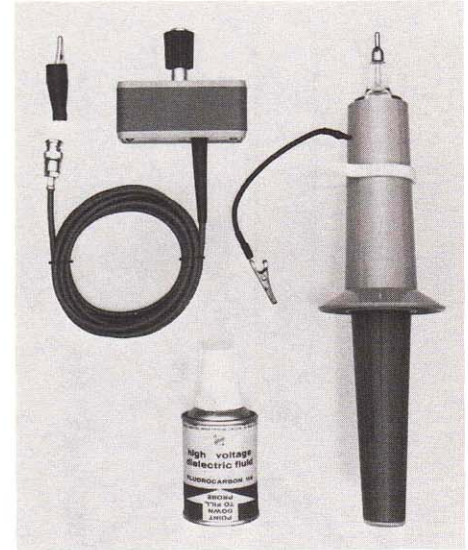

High Voltage Probe

Measure Up to 40 kV Peak Pulse

Up to 20 kV Dc + Peak Ac

1000X Attenuation

75 MHz Useful Bandwidth

For 1 MΩ Inputs

The P6015 provides 1000X attenuation for oscilloscope measurements up to 40 kV peak. Voltage or duty cycle derating is necessary for rf voltages at frequencies over 100 kHz, or in temperatures above 25°C.

The probe can be compensated for instruments with nominal input capacitance of 12 pF to 47 pF.

CHARACTERISTICS

Voltage Rating — 40 kV peak pulse; 20 kV dc or RMS continuous at 25°C. P-p voltage derating is necessary for cw frequencies higher than 100 kHz or in temperatures above 25°C. At 10 MHz the maximum allowable p-p voltage is 13 kV. **Attenuation** — 1000x. **Input Resistance** — 100 MΩ. **Input Capacitance** — ≈ 3 pF. **Probe Rise Time** — ≈ 4 ns. **Temperature Range** — 10°C to 55°C. **Cable Length** — 10 ft.

INCLUDED ACCESSORIES

- 015-0049-00 1 COMPENSATING BOX, BNC
- 344-0005-00 1 CLIP, alligator (AS)
- 352-0056-00 1 PROBE HOLDER
- 252-0120-00 1 CAN, high-voltage dielectric fluid (BH)
- 016-0128-02 1 CARRYING CASE

Order P6015 1000X Probe, 10 ft cable,

010-0172-00 \$555

P6028 Dc to 17 MHz 1X

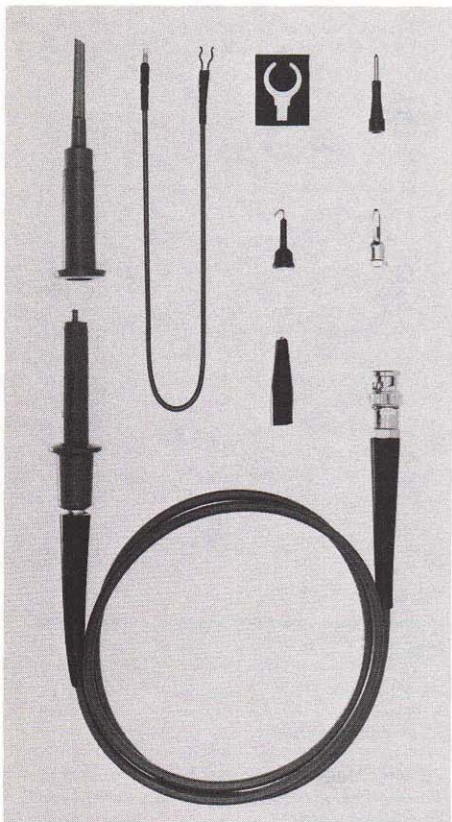

Dc to 17 MHz 1X

General Purpose

The P6028 is a general-purpose 1X voltage probe designed for use with Tektronix Oscilloscopes that have BNC input connectors.

CHARACTERISTICS

Attenuation — 1X. **Input Resistance** — 1 M Ω , instrument input R included. **Input Capacitance** — 30 pF for 3.5 ft probe cable; 47 pF for 6 ft version; 70 pF for 9 ft version; 92 pF for 12 ft version, instrument capacitance excluded. For total input capacitance of the system, add input C of instrument. **Probe Rise Time** — \approx 10 ns. **Bandwidth** — Dc to 17 MHz. **Voltage Rating** — 600 V dc or ac p-p. P-p voltage derating is necessary for cw frequencies higher than 1 MHz. At 10 MHz, the maximum allowable p-p voltage is 60 V.

INCLUDED ACCESSORIES

- 175-0125-01 1 LEAD, ground, 30 cm (12 in) (AX)
- 352-0068-00 1 HOLDER, probe, molded
- 344-0046-00 1 CLIP, alligator (AU)
- 013-0071-00 1 TIP, probe, retractable hook (AD)
- 134-0013-00 1 PLUG, tip, banana (AF)
- 206-0105-00 1 TIP, probe, hook (AM)
- 206-0060-00 1 TIP, probe, 0.080 in dia (AI)

ORDERING INFORMATION

| | |
|------------------------------|-------------|
| P6028 1X Probe, 6 ft, | |
| 010-0075-00 | \$48 |
| 3.5 ft, 010-0074-00 | Add \$48 |
| 9 ft, 010-0076-00 | Add \$48 |
| 12 ft, 010-0077-00 | Add \$48 |

Included Accessories with double alpha codes are pictured on pages 338 and 339.

P6053B Dc to 250 MHz 10X

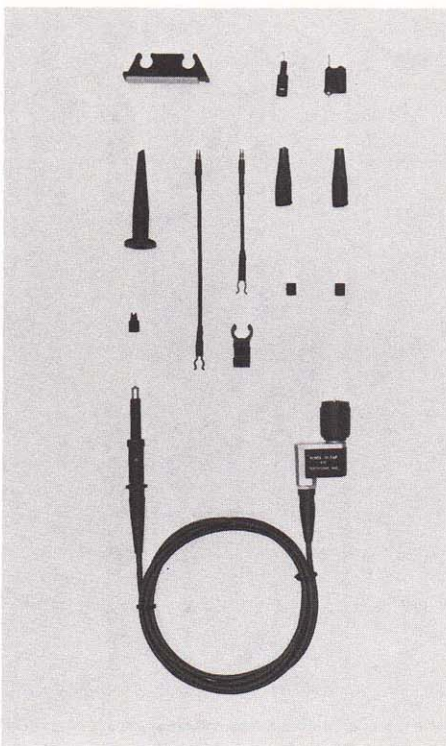

Miniature

Fast Rise Time

The P6053B is a miniature fast-rise 10X probe designed for Tektronix Instruments having a nominal input capacitance of 15 to 24 pF. The probe has a pushbutton for actuating the trace-identify function of the oscilloscope mainframe and readout capability.

CHARACTERISTICS

Attenuation — 10X. **Input Resistance** — 10 M Ω . **Input Capacitance** — 9.5 pF with 3.5 ft probe, 12.5 pF with 6 ft version, 13.5 pF with 9 ft version. **Bandwidth** (with 225 MHz or greater oscilloscope — \approx 200 MHz for 3.5 and 6 ft versions, \approx 115 MHz for the 9 ft version. **Voltage Rating** — 500 V (dc + peak ac). Peak voltage derating is necessary for cw frequencies higher than 5 MHz. At 10 MHz, the max allowable peak voltage is 275 V; 23 V at 100 MHz, 18 V at 150 MHz.

INCLUDED ACCESSORIES

- 013-0107-03 1 TIP, probe, retractable (BS)
- 352-0351-00 1 HOLDER, probe
- 206-0114-00 1 TIP, hook probe, (CK)
- 013-0085-00 1 TIP, probe, bayonet (BM)
- Trace Identify Function for scopes with CRT Readout
- 175-0124-01 1 LEAD, ground, 13 cm (5 in) (AW)
- 175-0263-01 1 LEAD, ground, 7.5 cm (3 in) (AV)
- 344-0046-00 2 CLIP, alligator (AU)
- 166-0404-01 2 INSULATING SLEEVE, electrical (CH)

ORDERING INFORMATION

| | |
|--------------------------------|--------------|
| P6053B 10X Probe, 6 ft, | |
| 010-6053-13 | \$140 |
| 3.5 ft, 010-6053-11 | Add \$140 |
| 9 ft, 010-6053-15 | Add \$140 |

P6055 20,000:1 Cmrr 10X

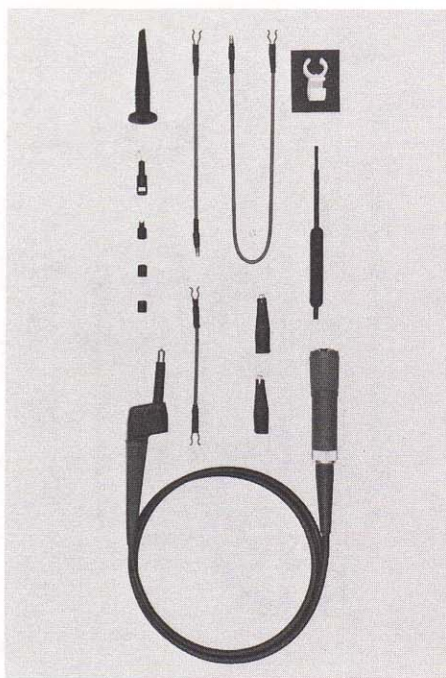

Low Cmrr

Low Capacitance

Dc — 60 MHz

The P6055 is a miniature, low-capacitance, 10X probe designed for use with Tektronix Differential Amplifiers having nominal input capacitances from 20 pF to 47 pF. The attenuation ratio is adjustable to 10X to compensate for differences in input resistance of the amplifier (the amplifier input resistance must be 1 M Ω \pm 2%). A special locking type readout connector allows the probe to be used with instruments with or without readout capability.

When two P6055 Probes are used to drive the two inputs of a differential amplifier, the ability to change the attenuation ratio of one probe versus the other is helpful in maintaining the cmrr of the system.

CHARACTERISTICS

Cmrr — 20,000:1 from dc to 1 kHz derating to 100:1 at 20 MHz. **Attenuation** — Adjustable to 10X. **Input Resistance** — 1 M Ω \pm 0.5%. **Input Capacitance** — \approx 10 pF when used with instrument that has 20 pF input capacitance; 12.5 pF when used with instrument that has 47 pF input capacitance. **Maximum Useful Bandwidth** — 60 MHz. **Typical Probe Rise Time** — 5.8 ns. **Maximum Voltage** — 500 V (dc + peak ac) from dc to 12 MHz. P-p voltage derates to 100 V at 70 MHz.

INCLUDED ACCESSORIES

- 013-0107-03 1 TIP, probe, retractable (BS)
- 003-0675-01 1 ADJUSTABLE TOOL, probe (CU)
- 175-0124-01 1 LEAD, ground, 13 cm (5 in) (AW)
- 175-1256-00 1 LEAD, electrical, 13 cm (6 in) (BG)
- 175-0125-01 1 LEAD, ground, 30 cm (12 in) (AX)
- 206-0114-00 1 TIP, hook probe, (CK)
- 344-0046-00 2 CLIP, alligator (AU)
- 166-0404-01 2 INSULATING SLEEVE, electrical (CH)
- 352-0090-00 1 HOLDER, probe

ORDERING INFORMATION

| | |
|--|--------------|
| P6055 10X Differential Probe, 3.5 ft, | |
| 010-6055-01 | \$220 |
| Matched Pair of P6055 | |
| 015-0437-00 | \$400 |

P6060 Dc to 35 MHz 10X

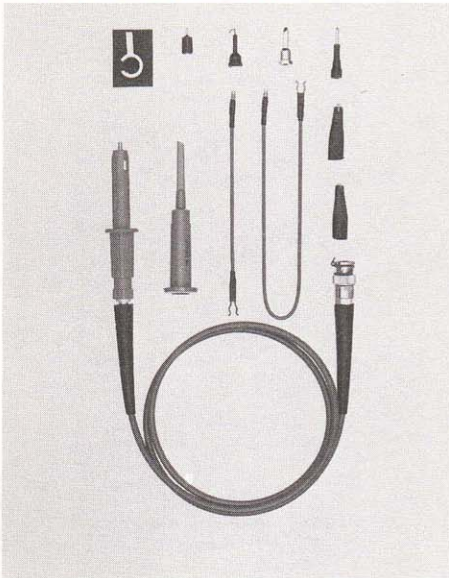

Precision Attenuation

Dc - 35 MHz

The **P6060** is a precision passive probe with 10X attenuation, for use with Tektronix low and mid-frequency oscilloscopes used in differential applications. The precise attenuation also provides greater accuracy for single-ended input applications, such as amplitude measurements with a differential comparator. The probe can be compensated for use with any amplifier input having a nominal input capacitance of 15 to 55 pF and input resistance of 1 M Ω .

The BNC-type connector utilizes a special grounding clip to shift the deflection factor indicator to 10X normal reading in 5000-Series Oscilloscopes.

CHARACTERISTICS

Attenuation — 10X. Accuracy when used with a 1 M Ω \pm 0.15% instrument input will be within \pm 0.4%. When used with a 1 M Ω \pm 2% instrument input the accuracy will be within \pm 2%. **Input Resistance** — 10 M Ω within \pm 0.25% within a 1 M Ω \pm 0.15% instrument input; 10 M Ω within \pm 0.4% when used with a 1 M Ω \pm 2% instrument input. **Input Capacitance** — \approx 6.0 pF for 3.5 ft probe cable when used with instrument having 15 pF input capacitance; \approx 7.7 pF with 6 ft version; \approx 9.5 pF with 3.5 ft version when used with 55 pF instruments; \approx 11.5 pF for 6 ft version. **Cmrr (Probe Pair)** — At least 400:1 (with 5A20N or 5A21N) dc to 30 kHz. **Bandwidth** — at least 35 MHz with 3.5 ft probe (with scope bandwidth of at least 60 MHz); 25 MHz with 6 ft probe. **Maximum Input Voltage** — 600 V dc plus peak ac. P-p derating is necessary for cw frequencies higher than 3 MHz. Maximum input voltage at 50 MHz is 50 V.

INCLUDED ACCESSORIES

- 206-0060-00 1 TIP, probe 0.080 (Al)
- 344-0046-00 2 CLIP, alligator (AU)
- 134-0013-00 1 PLUG, tip, banana (AF)
- 175-0125-01 1 LEAD, ground, 30 cm (12 in) (AX)
- 175-0124-01 1 LEAD, ground, 13 cm (5 in) (AW)
- 206-0105-00 1 TIP, probe, hook (AM)
- 206-0015-00 1 TIP, probe, (0.055 in dia) (AH)
- 013-0071-00 1 TIP, probe, retractable hook (AD)
- 352-0090-00 1 HOLDER, probe

ORDERING INFORMATION

- P6060 10X Probe, 6 ft,**
- 010-6060-03** \$78
- 3.5 ft, Order 010-6060-01 \$78

P6062B Dc to 100 MHz

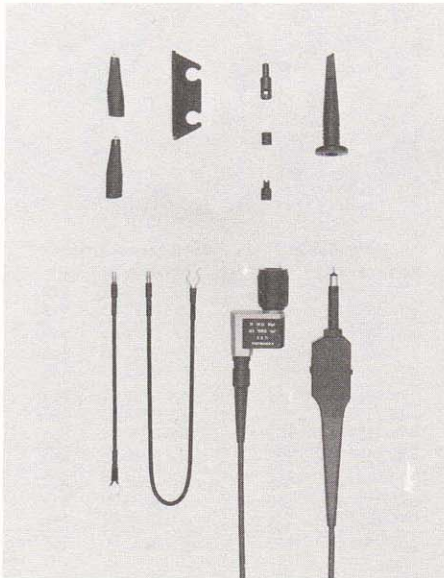

1X - 10X Selectable Attenuation

Switch on Probe Body

The **P6062B** is a passive dual attenuation probe designed for Tektronix Oscilloscopes with bandwidths to 100 MHz. A sliding switch on the probe body selects 1X or 10X attenuation. The probe provides readout coding and a pushbutton for actuating a ground reference in the 1X or 10X position. The ground reference can be used as a means of trace identification for a multitrace display. The P6062B can be compensated with instruments having a nominal input capacitance of 15 to 47 pF. The 1X position of the probe allows the use of the full instrument sensitivity. This is valuable when evaluating small signals of 10 MHz or less. The 1X-10X switch allows the user to switch in and out a decade of sensitivity without returning to the oscilloscope. The user may also arbitrarily switch from 1X to 10X in order to evaluate the effects of loading by the oscilloscope.

CHARACTERISTICS

Attenuation — 10X and 1X. **Input Resistance** — 1X position, 1 M Ω ; 10X position, 10 M Ω \pm 0.5%, oscilloscope input resistance must be 1 M Ω within 2%. **Input Capacitance** — 3.5 ft probe cable is 100 pF in the 1X position, 13.5 pF in the 10X position; 6 ft version is 105 pF in the 1X position, and 14 pF in the 10X position. 9 ft probe cable is 135 pF in the 1X position and 17 pF in the 10X position. **Bandwidth** — 10X probe is at least 100 MHz for the 3.5 ft and 6 ft version; 95 MHz for the 9 ft version when used with a 100 MHz Oscilloscope. 1X probe is at least 8 MHz for the 3.5 ft version, at least 6 MHz for the 6 ft version and at least 4.5 MHz for the 9 ft version. **Voltage Rating** (10X Position) — 500 V (dc + peak ac derated with frequency and oscilloscope input coupling). 1X position, 100 V (dc + peak ac derated with frequency).

INCLUDED ACCESSORIES

- 352-0351-00 1 HOLDER, probe
- 206-0114-00 1 TIP, hook probe (CK)
- 013-0107-03 1 TIP, probe, retractable (BS)
- 175-0124-01 1 LEAD, ground, 13 cm (5 in) (AW)
- 175-0125-01 1 LEAD, ground, 30 cm (12 in) (AX)
- 344-0046-00 2 CLIP, alligator (AU)
- 166-0404-01 1 INSULATING SLEEVE, electrical (CH)
- 016-0521-00 1 POUCH, accessory

ORDERING INFORMATION

- P6062B Switchable Attenuation Probe, 6 ft,**
- 010-6062-13** \$150
- 3.5 ft, 010-6062-11 \$150
- 9 ft, 010-6062-15 \$150

P6063B Dc to 200 MHz

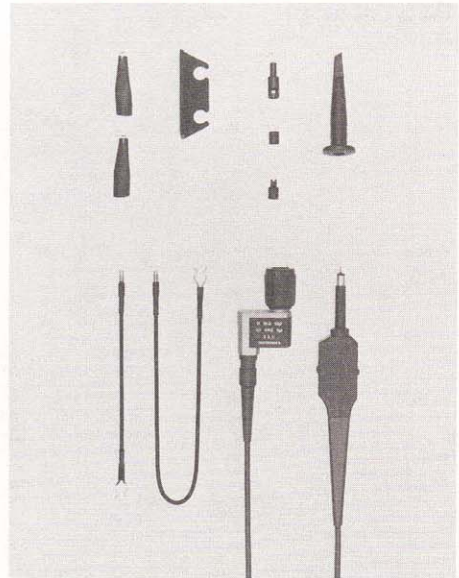

1X - 10X Selectable Attenuation

Switch on Probe Body

The **P6063B** is a fast-rise dual attenuation, passive probe designed for Tektronix Oscilloscopes with bandwidths greater than 100 MHz. A sliding switch on the probe body selects 1X or 10X attenuation. The probe provides readout coding and a pushbutton for actuating a ground reference in the 1X or 10X position. The ground reference can be used as a means of trace identification for a multitrace display. The P6063B can be compensated with instruments having a nominal input capacitance of 15 to 24 pF.

The 1X position of the probe allows the use of the full instrument sensitivity. This is valuable when evaluating small signals of 10 MHz or less. The 1X-10X switch allows the user to switch in and out a decade of sensitivity without returning to the oscilloscope. The user may also arbitrarily switch from 1X to 10X in order to evaluate the effects of loading by the oscilloscope.

CHARACTERISTICS

Attenuation — 10X and 1X. **Input Resistance** — 1X position, 1 M Ω ; 10X position, 10 M Ω \pm 0.5%, oscilloscope input resistance must be 1 M Ω within 2%. **Input Capacitance** — 3.5 ft probe cable is 80 pF in the 1X position, 11 pF in the 10X position, 6 ft version is 105 pF in the 1X position, and 14 pF in the 10X position. **Bandwidth** — 10X probe (3.5 ft and 6 ft versions) is at least 200 MHz when used with an oscilloscope with a bandwidth \geq 225 MHz. 1X probe for the 3.5 ft version is at least 12 MHz and for the 6 ft version at least 6 MHz. **Voltage Rating** — 500 V (dc + peak ac derated with frequency).

INCLUDED ACCESSORIES

- 352-0351-00 1 HOLDER, probe
- 206-0114-00 1 TIP, hook probe (CK)
- 013-0107-03 1 TIP, probe, retractable (BS)
- 175-0124-01 1 LEAD, ground, 13 cm (5 in) (AW)
- 175-0125-01 1 LEAD, ground, 30 cm (12 in) (AX)
- 344-0046-00 2 CLIP, alligator (AU)
- 166-0404-01 1 INSULATING SLEEVE, electrical (CH)
- 016-0521-00 1 POUCH, accessory

ORDERING INFORMATION

- P6063B Switchable Attenuation Probe, 6 ft,**
- 010-6063-13** \$180
- 3.5 ft, 010-6063-11 \$180

Modular Probe Replacement Parts

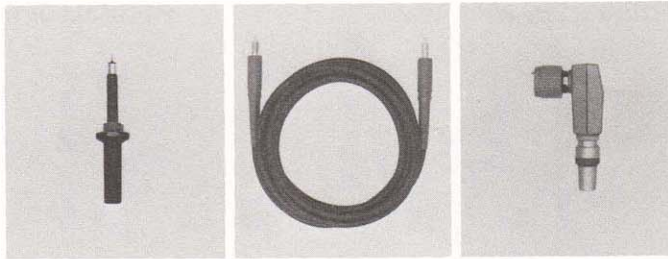

| Probe | Length | Probe Head | | Probe Cable | | Compensator/Connector | |
|--------|---------|-------------|------|-------------|------|-----------------------|------|
| P6101 | 1 Meter | 206-0223-00 | \$18 | 175-1661-00 | \$26 | 103-0189-00 | \$18 |
| | 2 Meter | 206-0223-00 | \$18 | 175-1661-01 | \$26 | 103-0189-00 | \$18 |
| | 3 Meter | 206-0223-00 | \$18 | 175-1661-02 | \$26 | 103-0189-00 | \$18 |
| P6105* | 1 Meter | 206-0216-00 | \$43 | 175-1661-00 | \$26 | 206-0219-00 | \$42 |
| | 2 Meter | 206-0217-00 | \$43 | 175-1661-01 | \$26 | 206-0220-00 | \$42 |
| | 3 Meter | 206-0218-00 | \$43 | 175-1661-02 | \$26 | 206-0221-00 | \$42 |
| P6106* | 1 Meter | 206-0216-00 | \$43 | 175-1661-00 | \$26 | 206-0237-00 | \$60 |
| | 2 Meter | 206-0217-00 | \$43 | 175-1661-01 | \$26 | 206-0238-00 | \$65 |
| | 3 Meter | 206-0218-00 | \$43 | 175-1661-02 | \$26 | 206-0239-00 | \$65 |
| P6107 | 2 Meter | 206-0217-00 | \$43 | 175-1661-00 | \$26 | 206-0247-00 | \$40 |
| P6108 | 1 Meter | 206-0224-00 | \$37 | 175-1661-00 | \$26 | 206-0227-00 | \$39 |
| | 2 Meter | 206-0225-00 | \$37 | 175-1661-01 | \$26 | 206-0228-00 | \$42 |
| | 3 Meter | 206-0226-00 | \$37 | 175-1661-02 | \$26 | 206-0229-00 | \$42 |
| P6149 | 2 Meter | 206-0234-00 | \$34 | 175-1661-01 | \$26 | 206-0235-00 | \$45 |

*The BNC Connector with readout may be replaced with 131-1799-01

Probe Ground Leads

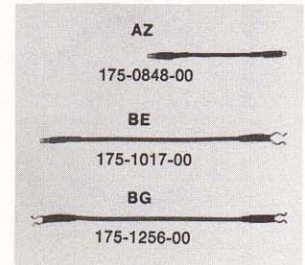
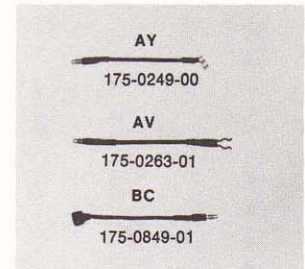

#6-32 Probe Tips and Accessories

The following tips and adapters can be used on all Tektronix Probes that accept a #6-32 screw-on tip, including the P6006, P6007, P6008, P6009, P6028, and P6060 Probes.

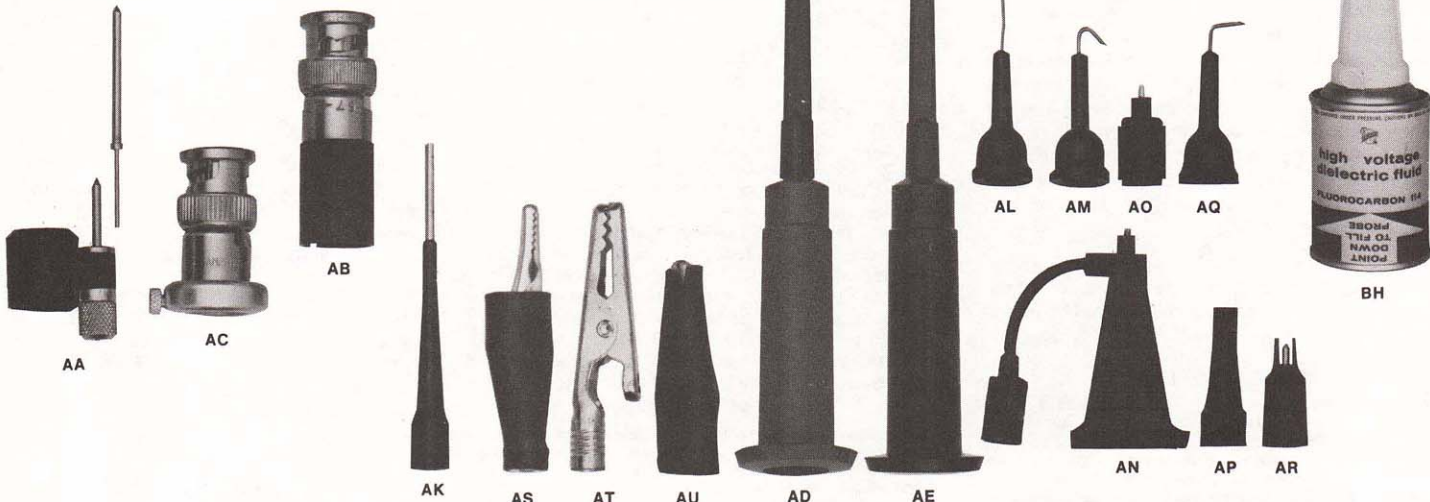

| CODE | DESCRIPTION | PART NUMBER | PRICE | CODE | DESCRIPTION | LENGTH (in) | PART NUMBER | PRICE |
|------|--|-------------|---------|------|-------------------------------------|-------------|-------------|--------|
| AA | Bayonet ground assembly | 013-0052-00 | \$ 6.50 | AV | Ground lead* | 3 | 175-0263-01 | \$2.00 |
| AB | Probe tip to BNC adapter | 013-0054-00 | 16.00 | AW | Ground lead* | 5 | 175-0124-01 | 2.00 |
| AC | Probe tip to BNC adapter (for P6028) | 013-0056-00 | 17.00 | AX | Ground lead* | 12 | 175-0125-01 | 2.00 |
| AD | Probe retractable hook tip | 013-0071-00 | 3.00 | AY | Ground lead for S-3A, P6056, P6057 | 3 | 175-0249-00 | 3.75 |
| AE | Probe retractable hook tip | 013-0071-01 | 3.00 | AZ | Ground leads for P6054, P6075 | 3 | 175-0848-00 | 1.50 |
| AF | Probe banana tip | 134-0013-00 | .70 | BA | 7A11, and P6201 | 5 | 175-0848-01 | 1.60 |
| AG | Probe ground cover (for P6009) | 166-0428-00 | 1.25 | BB | | 12 | 175-0848-02 | 1.60 |
| AH | Probe straight tip (0.055 in dia) | 206-0015-00 | .70 | BC | Ground leads for P6202 and P6420 | 3 | 175-0849-00 | 5.50 |
| AI | Probe spring tip (0.080 in dia) | 206-0060-00 | 1.50 | | | 6 | 175-0849-01 | 5.50 |
| AJ | Probe spring tip (accepts .065 in dia pin) | 206-0061-00 | 1.00 | BD | Ground lead for P6008 Environmental | 12 | 175-0925-00 | 3.50 |
| AK | Probe calibration tip (0.063 in dia) | 206-0100-00 | 10.00 | BE | Ground leads for S-3A, P6202, | 6 | 175-1017-00 | 3.00 |
| AL | Probe long straight tip (0.032 in dia) | 206-0104-00 | 1.00 | BF | and P6420 | 12 | 175-1018-00 | 3.00 |
| AM | Probe hook up | 206-0105-00 | 1.00 | BG | Ground lead for P6055 | 6 | 175-1256-00 | 4.50 |
| AN | Probe pin tip (accepts 0.025 in IBM SLT in) | 206-0134-03 | 4.00 | BH | High-voltage dielectric fluid | | 252-0120-00 | 4.50 |
| AO | Probe ground lead adapter (#6-32 to 0.025 in square pin closing) | 206-0137-01 | 1.75 | | | | | |
| AP | Probe spring tip (accepts 0.068 in dia pin) | 206-0168-00 | 2.25 | | | | | |
| AQ | Probe right angle hook tip | 206-0185-00 | 1.30 | | | | | |
| AR | IC test tip | 206-0203-00 | 1.25 | | | | | |
| AS | Alligator clip | 344-0005-00 | 3.60 | | | | | |
| AT | Alligator clip | 344-0045-00 | 1.25 | | | | | |
| AU | Miniature alligator clip | 344-0046-00 | 1.25 | | | | | |

*For the P6053B, P6054A, P6075A, P6101, P6105, P6106, P6108, P6149, and other probes requiring clip-on ground leads.

| DESCRIPTION | PART NUMBER | PRICE |
|-----------------------|-------------|--------|
| For 1/8 in dia cable | 016-0130-00 | \$6.00 |
| For 3/16 in dia cable | 016-0127-00 | 6.00 |
| For modular cable | 016-0633-00 | 3.75 |

Slip-on Probe Tips and Adapters

The following tips and adapters are designed for use with Tektronix Miniature Probes and accept a slip-on tip.

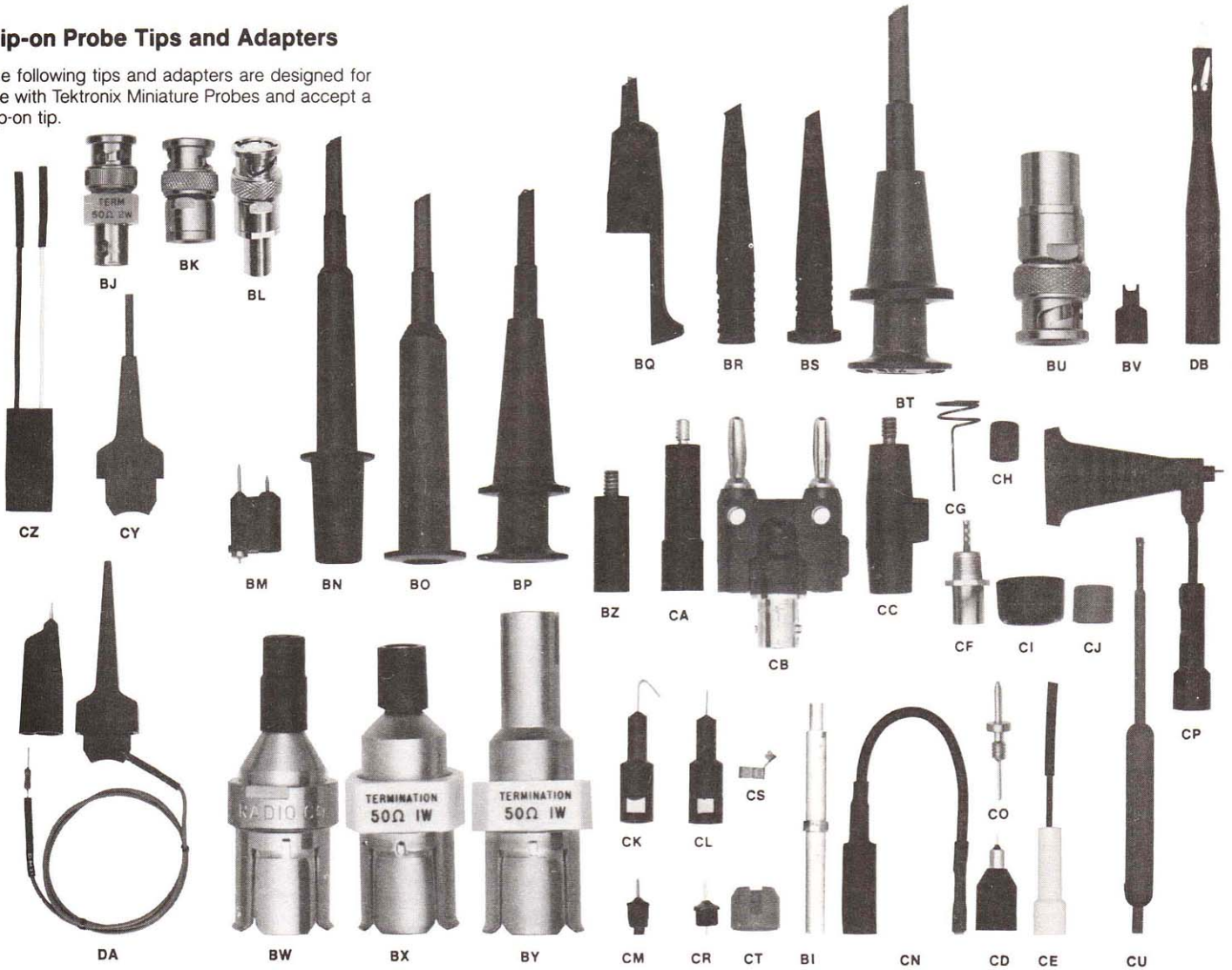

| CODE | DESCRIPTION | PART NUMBER | PRICE | CODE | DESCRIPTION | PART NUMBER | PRICE |
|------|--|-------------|--------|----------------|---|-------------|--------|
| BJ | Probe tip extractor | 003-0825-00 | \$1.85 | CD | Probe tip to test point jack (for P6201 only) | 103-0164-00 | \$5.00 |
| BK | Termination, 50 Ω | 011-0049-01 | 25.00 | CE | Probe tip flexible, adapts miniature probe to retractable hook tip (CY) | 103-0177-01 | 6.00 |
| BL | Probe tip to BNC adapter for all probes | 013-0084-01 | 8.00 | CF | Chassis mount test jack (for miniature probes, including modular) | 131-0258-00 | 4.00 |
| BM | Bayonet ground assembly | 013-0085-00 | 6.00 | CG | Ground contact (for P6201 only) | 131-1302-00 | 1.00 |
| BN | Retractable hook tip (for P6010 and P6048) | 013-0090-00 | 3.75 | CH | Miniature probe tip ground cover, insulating sleeve (for all miniature probes, including modular) | 166-0404-01 | .35 |
| BO | Retractable hook tip (for S-3A, P6202, and P6420) | 013-0097-01 | 6.50 | CJ | Ground lead, insulating sleeve (for P6201 only) | 166-0433-00 | .85 |
| BQ | Retractable hook tip (for all modular probes) | 013-0105-00 | 6.50 | CK | Insulating sleeve, electrical (for P6201 only) | 166-0557-00 | .40 |
| BP | Retractable hook tip (for 7A11 and P6401) | 013-0106-00 | 8.50 | CL | Probe tip hook (for all miniature probes, including modular) | 206-0114-00 | 2.50 |
| BR | Retractable hook tip (for 211, 212, 213, 214, 221) | 013-0107-02 | 3.00 | CM | Probe tip straight (for all miniature probes, including modular) | 206-0114-01 | 2.50 |
| BS | Retractable hook tip (for P6053B, P6055, P6062B, P6063B, P6101, P6105, P6106, P6108, and P6149) | 013-0107-03 | 3.00 | CN | Replaceable probe tip, pkg of 10. All miniature probes including modular except P6202 and P6420 | 206-0191-03 | 16.00 |
| BT | Retractable probe tip (for P6201 only) | 013-0135-00 | 3.75 | CN | Probe tip flexible for 0.025 sq pin | 206-0193-00 | 7.25 |
| BU | Probe tip to BNC adapter (for P6201 only) | 013-0145-00 | 13.50 | CO | Replaceable probe tip (for P6201 only) | 206-0200-00 | .40 |
| BV | Miniature probe tip cover, IC tester, Package of 10 | 015-0201-04 | 6.00 | CP | Probe pin tip (accepts 0.025 in IBM SLT pin) | 206-0209-00 | 3.25 |
| | Package of 100 | 015-0201-05 | 17.00 | CR | Replaceable probe tip for P6202 and P6420, pkg of 10 | 206-0230-03 | 15.00 |
| BW | Miniature probe tip to GR adapter | 017-0076-00 | 42.00 | CS | Electrical contact | 214-0283-00 | .70 |
| BX | Miniature probe tip to GR 50 Ω termination adapter | 017-0088-00 | 44.00 | CT | Ground contact insulator (for P6201 only) | 342-0180-00 | .50 |
| BY | P6201 probe tip to GR 50 Ω termination adapter | 017-0094-00 | 50.00 | CU | Adjustment tool, probe | 003-0675-01 | 1.70 |
| BZ | Miniature probe to #6-32 adapter (for P6045, P6046, P6202, 7A11, S-3A) | 103-0051-00 | 3.75 | CV, CW, and CX | Coaxial cable — see page 346. | | |
| CA | Miniature probe to #6-32 adapter (for all miniature probes except P6045, P6202, includes all modular probes) | 103-0051-01 | 3.75 | CY | Miniature retractable hook tip | 206-0222-00 | 3.00 |
| CB | Female to dual banana adapter, BNC | 103-0090-00 | 7.50 | CZ | Dual lead adapter for miniature probes | 015-0325-00 | 12.50 |
| CC | Miniature probe to #6-32 adapter with ground connection | 103-0131-00 | 5.00 | DA | For LA Probe tip for tri-state logic (308) | 206-0252-01 | 15.00 |
| | | | | DB | Probe tip, IC Grabber | 013-0191-00 | 10.00 |

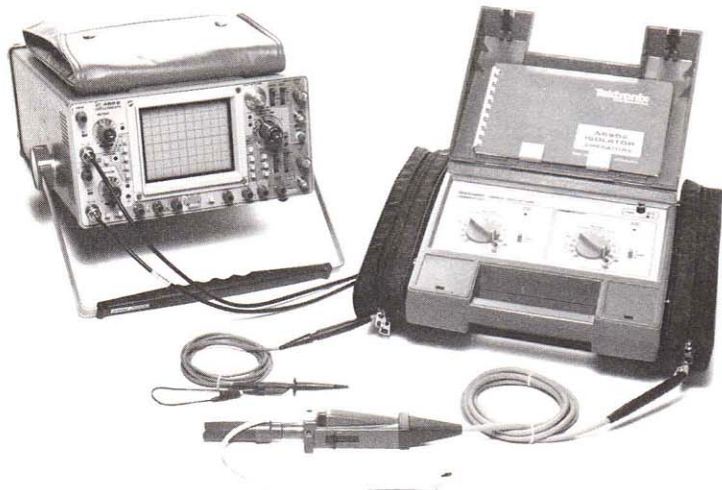

ISOLATION ACCESSORIES FOR FLOATING MEASUREMENTS

In the world of oscilloscope use, the problem of floating measurements is a pressing need that often causes users to employ questionable and often unsafe practices to allow the oscilloscope chassis to float at some potential other than ground. Such practices are parts of a larger problem concerning equipment grounding. In a recent study of computer data, OSHA found that faulty grounding of electrical equipment connected by cord and plug was one of the most common violations of accepted safety rules.

Recognition of the measurement need and a firm commitment to test and measurement product safety have resulted in two new isolator products from Tektronix. These products will allow you to make those necessary floating measurements with minimum risk of operator injury or test equipment damage. Both meet worldwide safety standards; including UL 1244, CSA Electronics Bulletin 556B, IEC 348 and BS 4743.

But, before we delve into the technical and applications aspects of these new accessories, perhaps some background information would be appropriate. Just what are floating measurements and why are such measurements necessary?

A Need Met

Users of oscilloscopes often must make measurements in which neither point of the measurement is at ground potential. The signal common may be at times hundreds of volts from ground. Also, many such measurements require rejection of high amplitude common-mode signals in order to examine low-level signals. Unwanted ground currents may add bothersome hum and ground loops to displays.

Ground Loops

The potential difference between two green wire grounds on separate mains circuits may be as great as 5 volts RMS at 60 Hz. An oscilloscope plugged into one main circuit would thus measure a signal on a system plugged into another mains circuit equal to the sum of the signal plus the difference between the green wire grounds. A logic signal typically swings 1.8 volts. With this logic signal imposed on that 5 volts 60 Hz signal, making measurements becomes difficult if not impossible. Traditional oscilloscope designs cannot effectively cope with these problems alone. All too often, the problems almost force users into employing dangerous measurement techniques. But why is this?

Most oscilloscopes have a "signal common" terminal that is connected to the protective grounding system. This is because all signals applied to or from an oscilloscope must have a common

connection point. This is ordinarily the oscilloscope chassis, which is usually at zero volt. To prevent one input from becoming live when another is connected to a signal, the common connection point is connected to the protective grounding system of the oscilloscope.

While this arrangement usually works well and is safe for the user, it also provides that, with few exceptions, all measurements must be made with respect to ground. This constrains the oscilloscope (at least in a single measurement) from being used to measure potential differences between points where neither is at ground potential. Also, measurements can be exceedingly difficult to perform because probes and connectors can introduce unwanted circulating currents, ground loops, into the circuit under test. Such circulating currents impose noise on the signals to be examined and can interfere with system operation through the connection of the probe ground.

"Floating the scope" is the usual technique that is used in such measurements. It is the technique of defeating the protective grounding system — disconnecting the "signal common" from ground — and allowing accessible oscilloscope parts, such as the chassis, enclosure, connectors, and controls to assume the potential of the point at which the ground lead is connected. And it is dangerous, for two reasons. First, and most obvious, is the possibly high voltages on exposed metal parts of the oscilloscope that present a shock hazard to the operator. Second, and not so obvious, is the cumulative stresses on the oscilloscope power transformer insulation. Such stresses can cause future failure, with attendant shock and fire hazard, even after the oscilloscope is returned to properly grounded operation.

Safety Principles

Tektronix has over the years adopted many safety principles in the design of its products. Of particular concern to those making electrical and electronic measurements are these principles:

- Accessible parts shall not be live, even in the event of the single worst-case fault.
- Electronic devices (those devices that employ conduction in a vacuum, gas, or semiconductor) shall not be relied upon to protect the operator from electric shock.
- Products shall not develop insidious hazards during proper operation. (An insidious hazard is one that develops so gradually as to be well established before becoming apparent.)
- An operator shall not have to defeat a protective system to perform a measurement.
- No switch shall be placed in series with the protective grounding conductor.

Common Floating Measurement Techniques

Floating measurements can be performed using various methods. Each has limitations and some are safer and more reliable than others. In the following paragraphs, ten common methods of making floating oscilloscope measurements are reviewed. Note that four of these methods each violate two or more safety engineering principles. Tektronix strongly discourages such methods.

Isolation Amplifiers. The isolating amplifier is connected between the signal under investigation and the oscilloscope. With respect to the signal, the amplifier is completely insulated, with no accessible conductive parts. The signal is coupled across an insulating barrier to the oscilloscope. Use of the isolation amplifier maintains the usability of all scope functions.

The TEKTRONIX A6902 Isolator is an isolation amplifier consisting of two identical amplifiers, isolated from each other, from accessible parts, from the mains, and from ground. It enables an oscilloscope to measure potentials from ± 20 mV to ± 1500 volts. Each signal common lead can be independently connected to separate voltages up to + or - 1500 volts. The A6902 can measure two such signals simultaneously, in combination with any dual trace oscilloscope.

Indirect Grounding. Safety standards specify indirect grounding as an alternative to direct grounding. All of the grounding requirements apply, except that the grounding circuit need not be completed until the available voltage or current exceeds a prescribed amount.

The TEKTRONIX A6901 Ground Isolation Monitor is an indirect grounding device. It is connected between the mains and the test instrument. When activated, it disconnects the protective grounding system and monitors the voltage and current of the isolated ground. If this voltage exceeds 40 volts peak and a preselected current (0.5 mA, 3.5 mA, or 5.0 mA), the A6901 disconnects the power to the test instrument, sounds an alarm, and re-connects the protective grounding conductor.

The A6901 can be used with any grounded test instrument. It also tests ground continuity of the mains and will not activate if the mains ground is inadequate. It solves the problems of defeating the protective ground and provides the means for valid measurements.

Differential Techniques. The most popular solution to the need for a floating measurement is the A minus B quasi-differential technique. Most general-purpose dual-trace oscilloscopes (such as the TEKTRONIX 465B) have an ADD Mode in which the two channels (invert Ch 2) can be electrically subtracted, giving a display of the difference signal. This can be a problem when attempting to examine low-level control signals in the presence of high common-mode voltages. Also, the common-mode dynamic range is severely limited (± 6 divisions beyond screen height) and cmrr is low — approximately 100:1.

True differential solutions are amplifiers specifically designed to have good rejection of the common-mode signal and display only the difference signal. Because these amplifiers are basically two ground-referenced amplifiers, limited floating or common-mode capability is provided. Further, the ability to display a small signal in the presence of a large common-mode signal changes as a function of the absolute magnitude of the common-mode signal, as well as the ratio of the common-mode signal to the difference signal. Also, there are bandwidth limitations. The TEKTRONIX 7A13 provides 500 volts of common-mode dynamic range at 0.1 V/div with a cmrr of at least 1000:1 and a bandwidth up to 105 MHz.

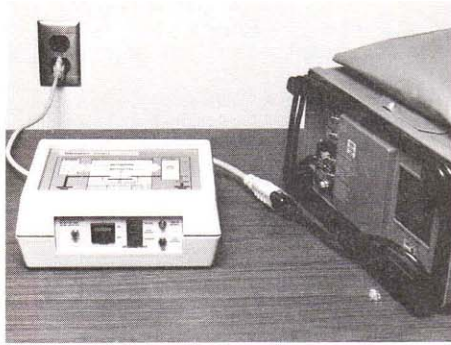

All-Insulated Oscilloscopes. The all-insulated oscilloscope has no accessible conductive parts. All accessible parts are made of insulating material. No protective system is defeated to make the measurement.

The completely insulated oscilloscope provides true isolation from both the mains and the signal common. It is not grounded but does not suffer the problems of being floated. It is not a differential amplifier and therefore does not suffer previously mentioned performance problems. But, it cannot be interconnected with other equipment because its internal common is at the elevated potential of the probe ground lead connection.

The Tektronix 200 Series Oscilloscopes are all-insulated, and are rated to 250 V with respect to mains insulation and 700 V peak with respect to the signal being measured (when operated on internal batteries). The 200 Series Oscilloscopes offer 3 x 5 cm display and bandwidths up to 5 MHz, with sweep speeds to 100 ns/div. These instruments are especially suitable for power supply and mechanical measurement applications.

Grounded Oscilloscopes. A grounded oscilloscope is capable of making floating measurements by making two separate measurements, recording the results, and subtracting the common-mode signal. This requires an oscilloscope system capable of waveform processing such as the TEKTRONIX 7854. The 7854 is capable of digitizing and storing the two waveforms and subtracting the common-mode signal mathematically. It is a highly sophisticated oscilloscope system with microprocessor-based waveform processing capability. The 7854 is especially suitable for those floating measurement applications that justify a substantial instrumentation investment.

Integrated Circuit Amplifiers. Some products purported to be isolators are nothing more than limited-performance IC differential amplifiers. Such units not only suffer from the problems of all differential amplifiers (limited dynamic range and ability to display small difference signals in the presence of large common-mode signals), but also suffer from lack of control and versatility. Impressive performance specifications disappear when probes, attenuators, power supply, and display connections are considered.

Isolation Transformers. Isolation transformers sometimes are employed between the mains and the test instrument to enable floating. To do this, the protective grounding system is defeated, resulting in violation of one safety principle: accessible parts are live due to the potential to which the signal common lead is connected.

The isolation transformer can provide some degree of protection in the event of a test instrument mains insulation failure — if the isolated mains does not have ground reference. If the transformer does not have a secondary ground reference, then a single insulation failure in the

test instrument will not result in a hazard, even though it is insidious. If the isolated main is ground-referenced (grounded neutral or grounded center-tap), then no protection is provided.

Also, during floating, the insulations of both the isolation transformer and the test instrument mains transformers are subjected to a voltage stress that is the sum of the mains voltage plus the signal common or floating voltage. This is because the two primary windings form a capacitive voltage divider among the floating chassis, the test instrument primary, and the isolation transformer primary. This voltage is extra — above the mains rating. Thus, if the mains insulation does break down, the test instrument is not grounded and a hazard exists. In this instance, the chassis will be live and the operator will have no indication of a problem. If grounded, smoke and fire may be the result. Using an isolating transformer to make a test instrument "safe" to float is a futile gesture and provides a false sense of security.

Double Insulated Mains. Some measuring equipment safety standards allow double insulation of the mains circuits instead of grounding (2-wire mains instead of 2-wire mains with earth connection). Ordinarily, double insulation provides protection equivalent to grounding. This is not true for measuring equipment, since measuring equipment has a second source of hazardous potentials — the circuit under test. Equal protection must be provided from all hazardous circuits, not just the mains circuits.

Ungrounded oscilloscopes are available in which protection from the mains is provided by double insulation, but where the signal common remains connected to the chassis enclosure and connectors. With respect to the signal being measured, these designs are the equivalent of defeating the protective grounding system.

Incidentally, unlike indirect grounding solutions that complete the protective grounding circuit when excessive voltage or currents are applied, this solution gives no warning to the operator that dangerous voltages and currents are present on the chassis.

Isolating Circuits. Some users, and at least one oscilloscope manufacturer, have placed semiconductor devices (back-to-back parallel rectifiers or zener diodes) in series with the protective grounding conductor. The purpose is to limit the excursion of voltage on accessible parts to a "safe" level. One oscilloscope has a switch in parallel with the semiconductors to restore the ground when isolation is not required. Unfortunately, these techniques violate two safety principles and lead to another insidious hazard. Most safety standards assume failure of semiconductors. Should a diode fail, there is no indication to the operator and an insidious hazard exists.

Also, safety standards commonly specify no switch in the protective grounding conductor; a switch defeats the protective grounding system just as cutting off the ground prong of the mains plug.

Defeating Grounds. Operators often defeat a test instrument protective grounding system by cutting off the ground prong or by using a 3-to-2 wire adapter. This technique allows the scope chassis, enclosure, and connectors to assume the potential of the probe ground lead connection.

The only protection for both the operator and nearby persons is to maintain distance and avoid simultaneously touching the test instrument and ground. Some safety officers require the work area to be roped off, a warning to be posted, and an observer to maintain surveillance on the operator. Some enforcement agencies accept these precautions under the heading of "reasonable caution" and choose not to cite violators. Although these precautions are laudable, we have described earlier the dangers inherent in floating oscilloscopes by defeating the protective grounding systems.

Summary

The following table provides a summary of the ten most common methods of performing floating measurements and highlights four as being unsafe.

METHODS OF MAKING FLOATING SCOPE MEASUREMENTS

| | Meets Safety Principles | Dynamic Range/Bandwidth | Flexibility | Ease of Operation | Isolation Voltage | Cost |
|-----------------------------|-------------------------|-------------------------|-----------------|-------------------|----------------------|----------|
| Isolation Amplifiers | ✓ | High | High | High | A6902 ≤1500 V | Moderate |
| Indirect Grounding | ✓ | High | High(-) | High | A6901 ≤40 V | Low |
| Differential Techniques | ✓ | Medium(+) | Medium(-) | Medium(-) | 7A13 ≤500 V | Moderate |
| All Insulated Oscilloscopes | ✓ | Medium(-) | Medium(-) | Medium(+) | 221 ≤250 V/≤750 V | Moderate |
| Grounded Oscilloscope | ✓ | High | High | High | 7854 ≤250 V | High |
| IC Isolation Amplifiers | ✓ | Low(-) | Low(-) | High | ≤2000 V | Low |
| Isolation Transformers | No | | Not Recommended | | | |
| Double Insulated Mains | No | | Not Recommended | | | |
| Isolating Circuits | No | | Not Recommended | | | |
| Defeating Grounds | No | | Not Recommended | | | |



A6901

Isolates Test Instrument from Ground

Continuous Voltage Monitoring

Activities Ground Connection with Over-Voltage Detection

Certified by Worldwide Safety Agencies

Compact, Portable

Placed in the circuit between an oscilloscope or other piece of test equipment and its power source, the A6901, acting as an indirect grounding device, allows floating measurements to be made with operator protection. It permits the elevation of the test instrument chassis to voltage levels other than ground to aid in logic circuit analysis or to circumvent the effects of ground loop noise problems.

In operation, the A6901 isolates the protective grounding system of a test instrument, monitors the voltage on that isolated system, and, when the voltage exceeds predetermined levels, interrupts the voltage supply to the instrument, sounds an alarm, and connects the isolated grounding system to the supply circuit grounding system. Also, the A6901 tests the power source for a functional ground before activating to the isolated mode.

Once in the isolated mode, the A6901 continuously monitors voltage between the test instrument and earth ground. If a 40 volt peak level is exceeded, at the selected current (0.5 mA, 3.5 mA, or 5 mA) the unit protection circuit activates and disconnects power from the test instrument, re-establishes the earth ground connection, and sounds an alarm.

Applications for the A6901 include elevating a test instrument chassis to logic reference voltages for more accurate logic level measurements, and isolating a test instrument chassis from common-mode voltages present on ground systems to eliminate undesirable noise from signal measurements.

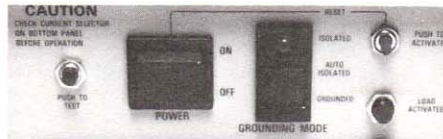

CHARACTERISTICS

ELECTRICAL CHARACTERISTICS

Trip Voltage (Dc) — 40 V peak (28 V RMS) or + and - 40 V (within 5%).

Trip Current — 0.5 mA, 5.0 mA to 3.5 mA.

Neutral-to-Ground Continuity — Between 3 and 10 V RMS (8.5 and 28.3 V p-p), 50 Hz.

Dc Voltage Trip Delay — < 20 ms.

Line Voltage Ranges — 90 to 128 V RMS, 180 to 250 V RMS.

Line Frequency Range — 48 to 66 Hz.

Maximum Power Consumption (No External Load) — 12 W at 115 V, 60 Hz.

Load Power — 50 W max.

ENVIRONMENTAL CHARACTERISTICS

Temperature — Operating: -15° to +55°C (+5° to +131°F). Nonoperating: -62° to +85°C (-80° to +185°F). Meets MIL-T-28800B, Class 3.

Altitude — Operating: to 4,500 m (15,000 ft). Nonoperating: to 15,000 m (50,000 ft). Exceeds MIL-T-28800B, Class 3.

Humidity — Exceeds MIL-T-28800B, Class 3.

PHYSICAL CHARACTERISTICS

| Dimensions | cm | in |
|---------------------------|-----|-----|
| Height | 87 | 3.4 |
| Width | 206 | 8.1 |
| Depth | 153 | 6.0 |
| Weights | kg | lb |
| Net (without accessories) | 1.4 | 3.0 |
| Shipping | 2.3 | 5.0 |

INCLUDED ACCESSORIES

STANDARD INSTRUMENT, NORTH AMERICAN 120 V

161-0150-00 1 **LOAD CORD**, 17.5 cm, IEC Male to NA Female, 120 V

159-0190-00 1 **FUSE**, 3 AF, DIN, Metric

159-0051-00 1 **FUSE**, 3 AG, 0.062A, SLO

161-0066-00 1 **POWER CORD**, 3 m, North American Male to IEC Female

UNIVERSAL EURO, OPTION A1

161-0157-00 1 **LOAD CORD**, 17.5 cm, IEC Male to Euro Female, 240 V

159-0202-00 1 **FUSE**, 6.3 A, DIN, Metric

159-0074-00 1 **FUSE**, 0.1 A, DIN, Metric

161-0066-09 1 **POWER CORD**, 3 m, Euro Male to IEC Female

UNITED KINGDOM OPTION A2

161-0159-00 1 **LOAD CORD**, 17.5 cm, IEC Male to UK Female, 240 V

159-0202-00 1 **FUSE**, 6.3 A, DIN, Metric

159-0074-00 1 **FUSE**, 0.1 A, DIN, Metric

161-0066-10 1 **POWER CORD**, 3 m, UK Male to IEC Female

AUSTRALIA, OPTION A3

161-0158-00 1 **LOAD CORD**, 17.5 cm, IEC Male to Australian Female, 240 V

159-0202-00 1 **FUSE**, 6.3 A, DIN, Metric

159-0074-00 1 **FUSE**, 0.1 A, DIN, Metric

161-0066-11 1 **POWER CORD**, 3 m, Australia Male to IEC Female

SWITZERLAND, OPTION A5

161-0160-00 1 **LOAD CORD**, 17.5 cm, IEC Male to Swiss Female, 240 V

159-0202-00 1 **FUSE**, 6.3 A, DIN, Metric

159-0074-00 1 **FUSE**, 0.1 A, DIN, Metric

161-0154-11 1 **POWER CORD**, 3 m, Swiss Male to IEC Female.

ORDERING INFORMATION

A6901 Ground Isolation Monitor \$425

INTERNATIONAL POWER CORD AND PLUG OPTIONS

Option A1 Universal Euro 220 V/16A **No Charge**

Option A2 UK 240 V/13A **No Charge**

Option A3 Australian 240 V/10A **No Charge**

Option A5 Switzerland 220 V/10A **No Charge**

(North American 240 V not available. Neutral not grounded in 240 V N.A. Systems)



A6902

Dc to 15 MHz Bandwidth

Completely Insulated for User Protection

Two Probe Sizes and Ratings (1500 and 500 V)

Two Isolated Channels That can be Used Simultaneously

Compact, Portable

Meets Worldwide Safety Specifications

In recognition of the requirement to perform floating measurements and low-level signal measurements in the presence of high-amplitude common-mode voltages, Tektronix offers the A6902 Isolator. It is a dual-channel, optical- and transformer-coupled voltage isolator that allows safely grounded test instruments to make floating measurements at high sensitivity levels in the presence of large common-mode signals.

The A6902 acts as a buffer between the test instrument and the system under test and extends the range of the test instrument to 1500 V (dc plus peak ac) with the larger industrial probe and to 500 V (dc plus peak ac) with the smaller signal probe. Using a combination of optical and transformer coupling, the unit isolates signals from and allows the test instrument to be safely grounded.

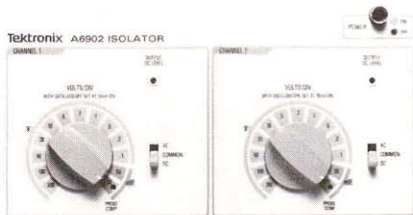

Designed for use with any dual-channel oscilloscope, the A6902 permits simultaneous observation of signals at two points in the same circuit or of signals in two different circuits. Separate, calibrated controls for volts per division on each channel provide for precise floating measurements. The larger, 1500-volt probes are used in high-voltage industrial applications and can grip studs as large as one-half inch; the smaller, 500-volt probes are used in signal applications in which access to crowded spaces is important and voltages are lower. Both probes are quickly interchangeable at the cable connectors inside the side pouch. The two pairs of probes and output cables are stored in the two side pouches for availability and convenience.

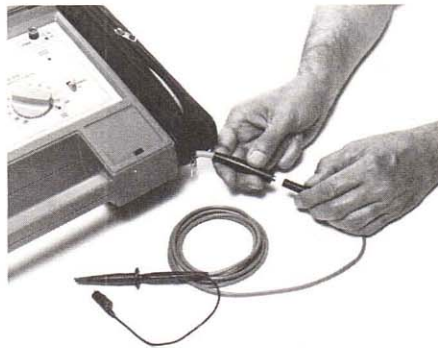
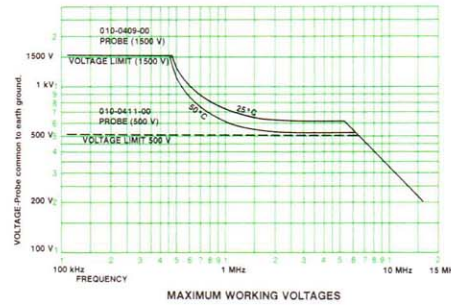

Operator safety is achieved through design. The all-plastic case and external controls protect the user during control settings and other operators. Other than probe tip connections, the user is never in close proximity to hazardous voltages. The A6902 is certified by worldwide safety agencies. These include: UL 1244, IEC 348, BS 4743, and CSA Bulletin 556B. A high degree of operator protection is thus afforded, when making non-grounded measurements of voltages as high as 1500 volts.

CHARACTERISTICS
ELECTRICAL CHARACTERISTICS

Deflection Factor — Probe Tip Sensitivity: 20 mV/div to 200 mV/div in 1-2-5 sequence with oscilloscope set to 10 mV/div. Accuracy: $\leq \pm 3\%$ of indicated VOLTS/DIV switch setting.

Maximum Working Voltage

Large Probe — Probe Center Tip to Earth Ground: 1500 V (dc + peak ac) Pulse Tested to 4.4 kV for 1 s. Probe Center Tip to Probe Common: 1500 V (dc + peak ac) to 900 kHz, derated to 105 V (dc + peak ac) at 15 MHz. Probe Common to Earth Ground: 1500 V (dc + peak ac) to 440 kHz, derated to 520 V (dc + peak ac) at 5.8 MHz then to 200 V (dc + peak ac) at 15 MHz.

Small Probe — Probe Center Tip to Earth Ground: 500 V (dc + peak ac). Probe Center Tip to Probe Common: 500 V (dc + peak ac) to 3 MHz, derated to 105 V (dc + peak ac) at 15 MHz. Probe Common to Earth Ground: 500 V (dc + peak ac), derated to 200 V (dc + peak ac) at 15 MHz.

Frequency Response — Bandwidth (dc coupled): ≥ 15 MHz (to -3 dB points). Bandwidth (ac coupled): ≤ 1 Hz (to lower -3 dB points).

Transient Response — 23 ns or less rise time.

Input Impedance — Resistance: $10\text{ M}\Omega \pm 3\%$.

Capacitance: Large Probe Tip to Common: ≈ 21 pF. Small Probe Tip to Common: ≈ 17.4 pF.

Common Mode Capacitance — ≈ 150 pF from probe common to earth ground.

Output Impedance — $\approx 50 \Omega$.

Tangential Noise — 2.0 mV.

Dc Drift With Temperature — ≤ 1 mV/°C or 0.1 div/°C at output.

Channel Isolation Voltage — Two 1500 V probes: 1500 V (dc to peak ac). Two 500 V probes: 1000 V (dc + peak ac).

Delay — Either Probe: 48 ± 3 ns from probe tip to output BNC.

Common Lead Signal Feedthrough — -110 dB from probe input to output BNC (with oscilloscope having 1 M Ω input resistance and up to 47 pF input capacitance, derated to -80 dB at 10 kHz and to -50 dB at 3.3 MHz).

POWER SOURCE CHARACTERISTICS

Line Voltage Ranges — Low: 90 to 132 V RMS. High: 180 to 250 V RMS.

Line Frequency Range — 48 to 440 Hz.

Power Consumption — 15 W at 115 V, 60 Hz.

ENVIRONMENTAL CHARACTERISTICS

Temperature — Operating: 0 to 50°C (32 to 122°F). Nonoperating: -55 to $+75$ °C (-67 °F to 167°F).

Altitude — Operating: to 4500 m (15,000 ft). Nonoperating: to 15,000 m (50,000 ft).

PHYSICAL CHARACTERISTICS

| Dimensions | cm | in |
|---------------|-----------|-----------|
| Height | 13.6 | 5.4 |
| Width | 39.4 | 15.5 |
| Depth | 34.4 | 13.5 |
| Weight | kg | lb |
| Net | 5.7 | 12.6 |
| Shipping | 7.5 | 16.6 |

INCLUDED ACCESSORIES

- 010-0411-01 2 PROBE, Isolation, 500 V
- 010-0409-00 2 PROBE, Isolation, 1500 V
- 159-0171-00 1 FUSE, 4.1 A, 250 V
- 161-0117-00 1 POWER CORD, Right Angle
- 012-0204-00 2 OUTPUT CABLE, 50 Ω , 2 m

ORDERING INFORMATION

- A6902 Isolator** **\$2300**
- Option 01 (Delete 2 500-V probes) **Sub \$100**
- Option 02 (Delete 2 1500-V probes) **Sub \$200**

INTERNATIONAL POWER CORD AND PLUG OPTIONS

- Option A1 Universal Euro 220 V/16A **No Charge**
- Option A2 UK 240 V/13A **No Charge**
- Option A3 Australian 240 V/10A **No Charge**
- Option A4 North American 240 V/15A **No Charge**
- Option A5 Switzerland 220 V/10A **No Charge**

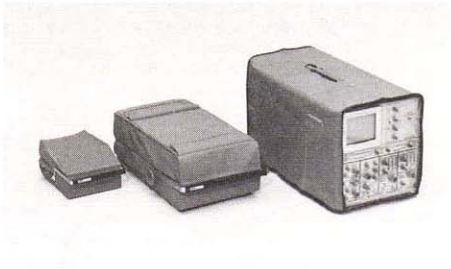

OSCILLOSCOPE PROTECTIVE COVERS

The cover provides protection for the oscilloscope during transport or storage. Made of waterproof blue vinyl, the covers are available for both laboratory and portable instruments. The covers for 500, 5000, and 7000 Series Laboratory Oscilloscopes have clear vinyl frontal areas.

| PROTECTIVE COVERS | | |
|-------------------------------------|-------------|---------|
| INSTRUMENT | PART NUMBER | PRICE |
| 200 Series | 016-0512-00 | \$15.00 |
| 323,324,1401A,1401A-1, 1501 | 016-0112-00 | 17.00 |
| 314,335 | 016-0612-00 | 85.00 |
| 326 | 016-0532-00 | 55.00 |
| 453A,454A,491 | 016-0074-01 | 18.00 |
| 455 | 016-0344-00 | 18.00 |
| 434,464,466 | 016-0365-00 | 21.00 |
| 465,465B,475,485 | 016-0554-00 | 17.00 |
| 560 Series (except 565,567, 568) | 016-0067-00 | 17.00 |
| 565,567,568 | 016-0069-00 | 20.00 |
| 540 Series | 016-0068-00 | 20.00 |
| 5000 Series | 016-0544-00 | 25.00 |
| 7300,7400,7600 Series | 016-0192-01 | 20.00 |
| 7704A,7900 | 016-0531-00 | 20.00 |

PLUG-IN UNIT CARRYING CASES

CARRYING CASE FOR 2, 3, 10, AND 11 SERIES

PLUG-IN UNITS — Accommodates two plug-in units.

Order 437-0070-00 \$85

CARRYING CASE FOR LETTER-SERIES OR 1-SERIES

PLUG-IN UNITS — Provides protection for one oscilloscope plug-in unit.

Order 437-0065-00 \$55

CARTS QUICK REFERENCE

| Product | Cart Model |
|----------------------------|------------|
| TM 503 | 3 |
| TM 504 | 3 |
| TM 506 | 205 |
| 21 | 206 |
| 31 | 206 |
| 432 | 200C |
| 434 | 200C |
| 455,465M | 200C |
| 464 | 200C |
| 465B | 200C |
| 466 | 200C |
| 475,475A | 200C |
| 485 | 200C |
| 491 | 200C |
| 520-522 | 205 |
| 528 | * |
| 530, 540, 550 Series | 3 |
| 560-Series | 3 |
| 576 | 206 |
| 577 | 206 |

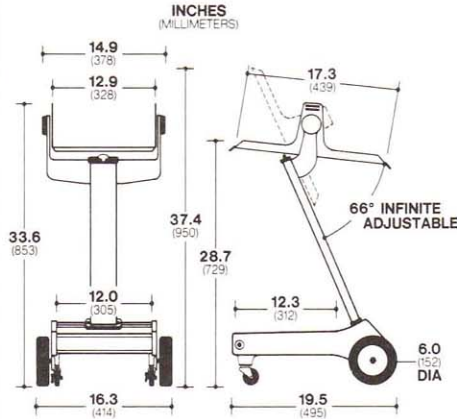

MODEL 200C

Recommended For:

All 400 Series Portable Scopes.

MODEL 200C includes brakes on front casters, safety belt to secure instrument on top tray. Blue vinyl finish. Net weight 7.3 kg, (16 lb). Shipping weight 12.2 kg, (27 lb).

Order Model 200C \$265

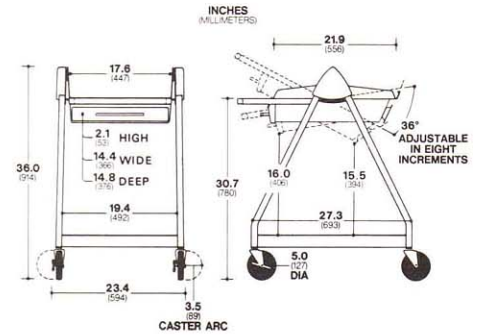

MODEL 205

Recommended For:

All rackmount width instruments. Note width dimension of top tray in diagram above. Rackmounting ears overhang sides of tray.

MODEL 205 includes brakes on front casters, storage drawer, power distribution module (three outlets, 15 ft cord). Blue vinyl finish. 19.5 kg, net weight 43 lb. 25.8 kg, shipping weight 57 lb.

Order Model 205 \$400

OPTIONAL SAFETY BELT recommended to secure instruments on top tray. 0.23 kg, net weight 0.5 lb. 0.45 kg, shipping weight 1 lb.

Order 346-0070-01 \$47



| | |
|-------------------|-----|
| 602-607 | * |
| 611 | 205 |
| 613 | 205 |
| 632 | 205 |
| 650 Series | 205 |
| 670 Series | 205 |
| 1105 | * |
| 1140A | 205 |
| 1340 | 205 |
| 1420 Series | * |
| 4601 | 206 |
| 4610 | 206 |
| 4623 | 206 |
| 4632 | 206 |
| 4661 | 206 |
| 4921 | 206 |

| | |
|-------------------|-----|
| 4922 | 206 |
| 5100 Series | 3 |
| 5400 Series | 3 |
| 7104 | 3 |
| 7313 | 3 |
| 7603 | 3 |
| 7613 | 3 |
| 7623A | 3 |
| 7633 | 3 |
| 7704 | 3 |
| 7834 | 3 |
| 7844 | 3 |
| 7904 | 3 |

*These products are applicable to several carts — see dimensions and features for your specific needs.

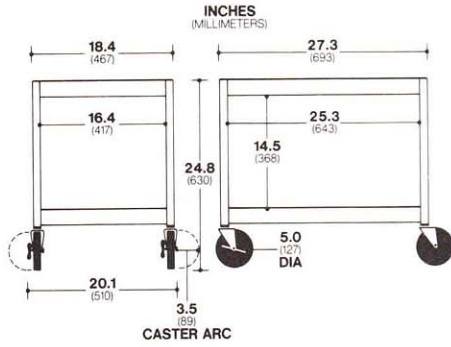

MODEL 206

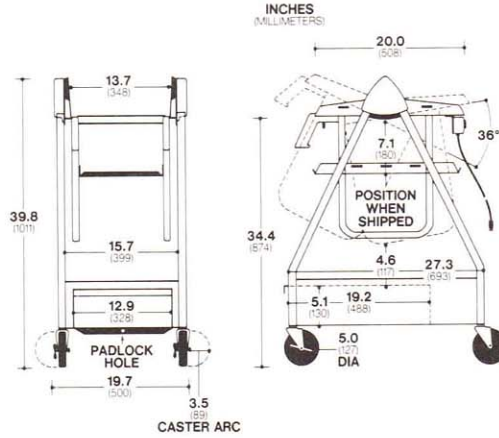

TEK LAB CART MODEL 3

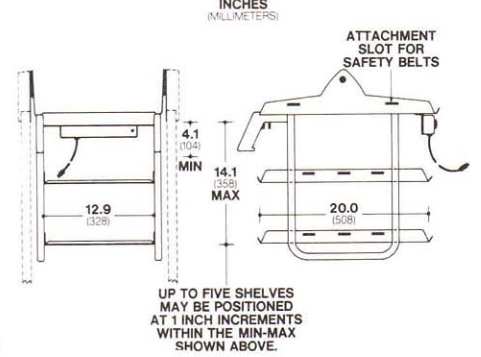

UP TO FIVE SHELVES
MAY BE POSITIONED
AT 1 INCH INCREMENTS
WITHIN THE MIN-MAX
SHOWN ABOVE.

Recommended For:

Computer terminals, calculators, and peripherals. General instruments, laboratory and office equipment.

MODEL 206 includes brakes on caster at one end of cart. Plastic laminate on top tray and base. Light gray vinyl finish. 13.6 kg, net weight (30 lb). 17.2 kg, shipping weight (38 lb).

Order Model 206 \$190

Recommended For:

Max recommended weight 65 lbs on tray top. 5100, 5400, and 7000 Series three and four plug-in oscilloscopes, all 400 Series, TM 503, and TM 504 mounted on top tray.

TM 503, TM 504 mounted on shelves.

MODEL 3 includes drawer in base with provision for padlock, brakes on all casters, power distribution module (four outlets and 15 ft cord), removable scope lock-down bar on top tray, one shelf, one safety belt, UL Listed. 25.8 kg, net weight (57 lb). 34 kg, shipping weight (75 lb). Blue vinyl finish.

Order Model 3 \$475

INTERNATIONAL VERSION deletes power module for shipment outside U.S.A.

Order Option 01 No Charge

Optional Accessories

Extra shelf with four mounting screws. Net weight 0.4 kg, (0.9 lb). Shipping weight 1.4 kg, (3 lb).

Order 436-0132-01 \$35

SAFETY BELT to secure instruments on top tray, shelves, or base 42 inch. (Not needed for 5000 or 7000 Series Scopes on top tray.) Net weight 0.23 kg, (0.5 lb). Shipping weight 0.45 kg, (1 lb).

Order 346-0136-01 \$23

For 7000 or 5000 Plug-in Storage on shelves contact Modified Products.

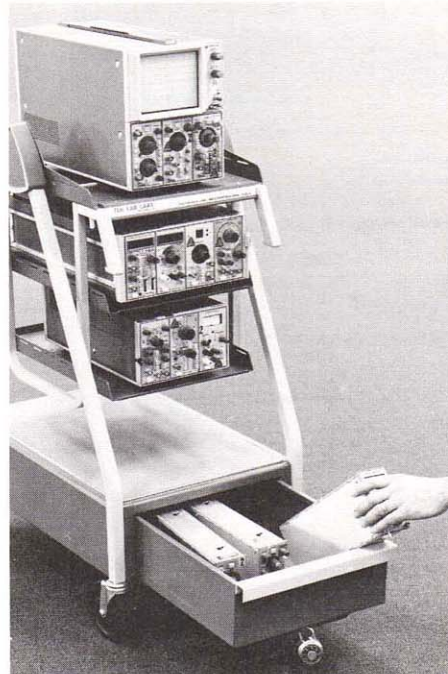

The Model 3 is shown with the 436-0132-01 Optional Shelf.



LOGIC PROBE TEST LEADS

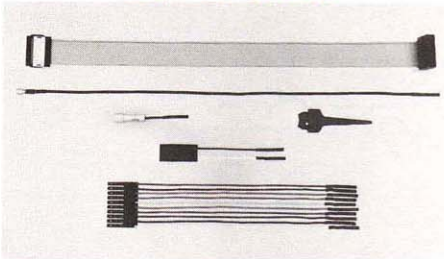

| | | |
|---|-------------|---------|
| 16 pin low profile dip clip (can be used with 14 or 16 pin ICs) | 015-0330-00 | \$35.00 |
| 10 wide comb set with grabber tips not included | 012-0747-00 | 46.00 |
| Miniature retractable hook tip | 206-0222-00 | 3.00 |
| Dual lead adapter for miniature probes | 015-0325-00 | 12.50 |
| Flexible probe tip, P6006 type | 103-0210-00 | 5.00 |
| Ground lead, P6006 type | 195-0234-00 | 4.50 |

PATCH CORDS

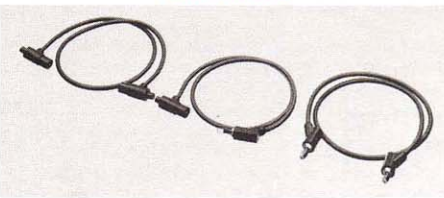

| | | |
|--|-------------|--------|
| BNC to BNC, 18 in | | |
| Red | 012-0087-00 | \$5.75 |
| Black | 012-0086-00 | 5.75 |
| BNC to banana plug-jack, 18 in | | |
| Red | 012-0091-00 | \$5.75 |
| Black | 012-0090-00 | 5.75 |
| Banana plug-jack to banana plug-jack, 18 in | | |
| Red | 012-0031-00 | \$5.50 |
| Black | 012-0039-00 | 5.75 |

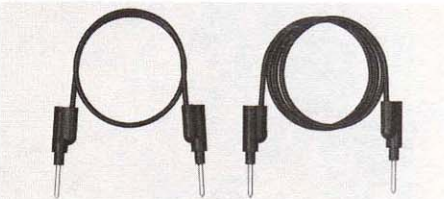

| | | |
|--|-------------|--------|
| Pin-jack to pin-jack, 0.08 in dia pin | | |
| Red, 8 in | 012-0179-00 | \$3.50 |
| Red, 18 in | 012-0180-00 | 3.50 |
| Black, 8 in | 012-0181-00 | 3.50 |
| Black, 18 in | 012-0182-00 | 3.50 |

TEST LEADS

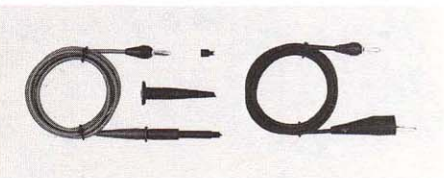

| | | |
|--|-------------|----------|
| Test Lead, Black, 4 ft | 012-0425-00 | \$ 10.25 |
| Test Lead, Red, 4 ft | 012-0426-00 | 15.50 |
| Test Lead, Black, 4 ft | 012-0426-01 | 15.50 |
| Test Lead set includes 012-0425-00, 012-0426-00, and 013-0107-03 | 012-0427-00 | 29.00 |

PERSONALITY MODULE TEST LEADS

| | | |
|---|-------------|---------|
| 40 Pin Dip Clip—10 cm cable (order M/F adapter below) | 015-0339-00 | \$40.00 |
| 40 Pin Dip Clip—30 cm cable | | |
| Male Adapter for 40 Pin (order M/F adapter below) | 015-0339-02 | 40.00 |
| Low Profile Dip Clip—for use with PM101/7D02 General Purpose Personality Module (or with individual leads such as the 10-wide comb set 012-0747-00) | 380-0560-05 | 15.00 |
| Female Adapter for 40 Pin Low Profile Dip Clip—for use with dedicated 7D02 personality modules | 380-0647-01 | 25.00 |

COAXIAL CABLES

BNC Connectors

| | | |
|--------------------------------------|-------------|---------|
| Coaxial, 50 Ω, 42 in | 012-0057-01 | \$17.00 |
| Coaxial, 75 Ω, 42 in | 012-0074-00 | 17.00 |
| Coaxial, 93 Ω, 42 in | 012-0075-00 | 25.00 |
| Coaxial, 50 Ω, 18 in | 012-0076-00 | 17.00 |
| Coaxial, 50 Ω, 18 in, Male to Female | 012-0104-00 | 23.00 |
| Coaxial, 50 Ω Precision, 36 in | 012-0482-00 | 25.00 |

N Connectors 50 Ω

| | | |
|----------------------------|-------------|---------|
| Coaxial N connectors, 6 ft | 012-0114-00 | \$25.00 |
|----------------------------|-------------|---------|

GR Connectors 50 Ω

| | | |
|-----------------------|-------------|----------|
| Coaxial 10 ns RG58A/U | 017-0501-00 | \$ 75.00 |
| Coaxial 5 ns RG213/U | 017-0502-00 | 160.00 |
| Coaxial 1 ns RG58A/U* | 017-0503-00 | 100.00 |
| Coaxial 20 ns RG213/U | 017-0504-00 | 90.00 |
| Coaxial 2 ns RG58A/U | 017-0505-00 | 110.00 |
| Coaxial 5 ns RG58A/U | 017-0512-00 | 75.00 |
| Coaxial 10 in RG213/U | 017-0513-00 | 75.00 |
| Coaxial 20 in RG213/U | 017-0515-00 | 90.00 |

*Connector on one end only.

50 Ω CABLES

SMA (3 mm) Connectors 50 Ω

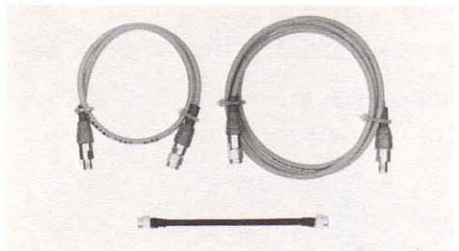

| | | |
|--------------------------|-------------|---------|
| Coaxial 2 ns | 015-1005-00 | \$80.00 |
| Coaxial 5 ns | 015-1006-00 | 130.00 |
| Coaxial semirigid 500 ps | 015-1015-00 | 40.00 |
| Coaxial semirigid 750 ps | 015-1017-00 | 35.00 |
| Coaxial 1 ns | 015-1019-00 | 105.00 |

BNC to BSM Connectors 50 Ω



| | | |
|------------------------|-------------|---------|
| Coaxial, 10 in, RG58 | | |
| BSM Female to BNC Male | 012-0128-00 | \$20.00 |
| Coaxial, 18 in, RG58 | | |
| BSM Female to BNC Male | 012-0127-00 | 20.00 |

50 Ω AIR LINE



The 20 cm 50 Ω air line is useful as a time-delay device and as an absolute impedance in a time-domain reflectometer system. The characteristic impedance is 50 Ω ± 0.4%. Time delay is 0.6698 ns ± 0.4%.

| | | |
|---------------|-------------|----------|
| 50 Ω Air Line | 017-0084-00 | \$165.00 |
|---------------|-------------|----------|

ADAPTERS



| | | |
|--------------------------|-------------|--------|
| BNC Female to BNC Female | 103-0028-00 | \$5.00 |
| BNC Male to BNC Male | 103-0029-00 | 5.50 |
| BNC T | 103-0030-00 | 6.50 |
| BNC Elbow Male to Female | 103-0031-00 | 6.00 |



| | | |
|-------------------------------|-------------|---------|
| BNC Male to GR | 017-0064-00 | \$60.00 |
| BNC Male to uhf Female | 103-0032-00 | 4.75 |
| BNC Male to Binding Post | 103-0033-00 | 4.75 |
| BNC Male to Dual Binding Post | 103-0035-00 | 12.00 |
| BNC Male to N Female | 103-0058-00 | 7.00 |



| | | |
|---------------------------|-------------|---------|
| BNC Female to clip leads | 013-0076-00 | \$17.50 |
| BNC Female to GR | 017-0063-00 | 43.00 |
| BNC Female to uhf Male | 103-0015-00 | 4.50 |
| BNC Female to BSM Male | 103-0036-00 | 15.00 |
| BNC Female to N Male | 103-0045-00 | 6.50 |
| BNC Female to Dual Banana | 103-0090-00 | 7.50 |

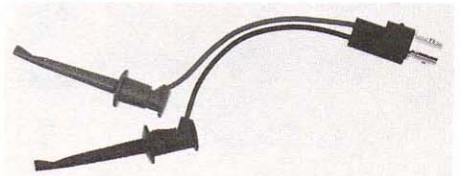

| | | |
|-----------------------|-------------|---------|
| BNC Female to EZ Ball | 013-0076-01 | \$17.50 |
|-----------------------|-------------|---------|



| | | |
|----------------|-------------|---------|
| GR to N Male | 017-0021-00 | \$27.00 |
| GR to C Male | 017-0027-00 | 55.00 |
| GR to N Female | 017-0062-00 | 43.00 |
| GR to C Female | 017-0065-00 | 55.00 |



| | | |
|---|-------------|---------|
| GR to BNC Female | 017-0063-00 | \$43.00 |
| GR to BNC Male | 017-0064-00 | 60.00 |
| 50 Ω termination, thru-line | 017-0083-00 | 80.00 |
| *(GR to BNC Male) | | |
| *Upper frequency limit vswr not specified | | |



| | | |
|----------------------|-------------|---------|
| N Male to GR | 017-0021-00 | \$27.00 |
| N Female to GR | 017-0062-00 | 43.00 |
| N Male to BNC Female | 103-0045-00 | 6.50 |
| N Female to BNC Male | 103-0058-00 | 7.00 |



| | | |
|--------------------------|-------------|---------|
| "F" Female to BNC Male | 013-0126-00 | \$15.00 |
| "F" Female to GR874 | 017-0089-00 | 45.00 |
| "F" Male to "F" Male | 103-0157-00 | 7.50 |
| "F" Male to BNC Female | 103-0158-00 | 8.50 |
| "F" Female to "F" Female | 103-0159-00 | 7.50 |

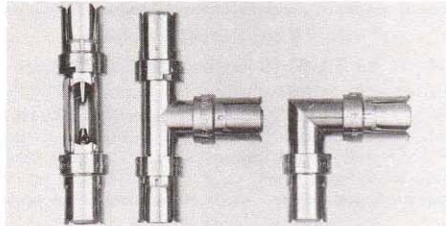

| | | |
|-------------------|-------------|---------|
| GR Insertion Unit | 017-0030-00 | \$80.00 |
| GR T | 017-0069-00 | 100.00 |
| GR Elbow | 017-0070-00 | 75.00 |



| | | |
|----------------------|-------------|----------|
| SMA Male to GR | 015-1007-00 | \$ 50.00 |
| SMA Female to GR | 015-1008-00 | 60.00 |
| SMA Male to N Female | 015-1009-00 | 50.00 |
| SMA Male to 7 mm APC | 015-1010-00 | 175.00 |

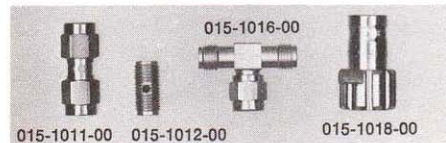

| | | |
|------------------------|-------------|---------|
| SMA Male to Male | 015-1011-00 | \$20.00 |
| SMA Female to Female | 015-1012-00 | 16.00 |
| SMA T | 015-1016-00 | 30.00 |
| SMA Male to BNC Female | 015-1018-00 | 8.00 |

ACCESSORY HOUSING



Accessory housing without electrical components is useful for applications requiring special circuitry.

| | | |
|-------------------|-------------|---------|
| Accessory Housing | 011-0081-00 | \$30.00 |
|-------------------|-------------|---------|

ATTENUATORS—TERMINATIONS



| | | |
|--|-------------|---------|
| 50 Ω ± 0.1% precision feed-through termination (dc -100 kHz, 11 V rms max) | 011-0129-00 | \$75.00 |
| 50 Ω feed through termination ¹ | 011-0049-01 | 25.00 |
| 50 Ω 10X (20 dB) attenuator ² | 011-0059-02 | 35.00 |
| 50 Ω 5X (14 dB) attenuator ² | 011-0060-02 | 35.00 |
| 50 Ω (6 dB) attenuator ² | 011-0069-02 | 35.00 |
| 50 Ω 2.5X (8 dB) attenuator ² | 011-0076-02 | 35.00 |
| 50 Ω feedthrough termination (5 W) ³ | 011-0099-00 | 40.00 |

Characteristics — Dc resistance is 50 Ω ± 1 Ω. Attenuation accuracy is ±2% dc, ±5% at 2 GHz. Power rating (except 011-0099-00) is 2 W average.

vswr
¹Less than 1.1 dc - 250 MHz and less than 1.2 dc - 500 MHz.
²Less than 1.1 dc - 1.0 GHz and less than 1.2 dc - 2.0 GHz.
³1.1 dc - 100 MHz.

| | | |
|--|-------------|---------|
| 75 Ω feedthrough termination | 011-0055-00 | \$25.00 |
| 93 Ω feedthrough termination | 011-0056-00 | 25.00 |
| 50 Ω to 75 Ω min loss attenuator | 011-0057-00 | 25.00 |
| 50 Ω to 93 Ω min loss attenuator | 011-0058-00 | 25.00 |
| 75 Ω 10X attenuator | 011-0061-00 | 30.00 |
| 93 Ω 10X attenuator | 011-0062-00 | 28.00 |
| 600 Ω feedthrough termination (1 W, dc to 1 MHz) | 011-0092-00 | 30.00 |
| 75 Ω to 50 Ω min loss attenuator (ac coupled) | 011-0112-00 | 60.00 |

CHARACTERISTICS

Accuracy of indicated attenuation ratio is ±2% at dc. Power rating of attenuators is 1/2 W and terminations 1 W. Voltage standing wave ratio (vswr) not specified.

ATTENUATORS and TERMINATORS



| | | |
|--|-------------|---------|
| Frequency range is dc to 12.4 GHz. Power rating is 2 W average, 300 W peak. Impedance is 50 Ω. | | |
| 10 dB attenuator | 011-0085-00 | \$70.00 |
| 20 dB attenuator | 011-0086-00 | 70.00 |
| 40 dB attenuator | 011-0087-00 | 90.00 |

GR



| | | |
|----------------------------|-------------|----------|
| 50 Ω 10X attenuator | 017-0078-00 | \$190.00 |
| 50 Ω 5X attenuator | 017-0079-00 | 190.00 |
| 50 Ω 2X attenuator | 017-0080-00 | 150.00 |
| 50 Ω termination, end-line | 017-0081-00 | 135.00 |

CHARACTERISTICS

Accuracy of indicated attenuation ratio is ±2% at dc, ±3% at 1 GHz. Voltage standing wave ratio (vswr) is less than 1.1 up to 1 GHz. Power rating is 1 W.

3 mm 50 Ω

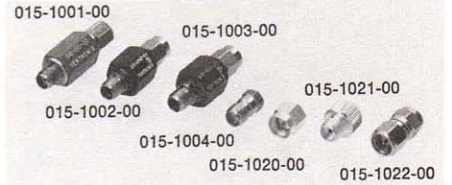

| | | |
|----------------------------------|-------------|----------|
| 50 Ω 2X attenuator | 015-1001-00 | \$120.00 |
| 50 Ω 5X attenuator | 015-1002-00 | 120.00 |
| 50 Ω 10X attenuator | 015-1003-00 | 120.00 |
| 50 Ω termination Female | 015-1004-00 | 60.00 |
| Short-Circuit termination Male | 015-1020-00 | 17.50 |
| Short-Circuit termination Female | 015-1021-00 | 24.00 |
| 50 Ω termination Male | 015-1022-00 | 32.00 |

CHARACTERISTICS

| | Dc— | | 12.40 GHz | | 18.00 GHz | | Power |
|------------------|----------------|------|----------------|------|-------------|--|-------|
| | Atten Accuracy | Vswr | Atten Accuracy | Vswr | Contin-uous | | |
| Termination ±1 Ω | ±1 Ω | 1.15 | ±1 Ω | 1.15 | 0.5 W | | |
| 2X (6 dB) | ±0.75 dB | 1.40 | ±1.00 dB | 2.00 | 1.0 W | | |
| 5X (14 dB) | ±0.75 dB | 1.40 | ±1.00 dB | 1.60 | 1.0 W | | |
| 10X (20 db) | ±0.75 dB | 1.40 | ±1.00 dB | 1.60 | 1.0 W | | |

50 Ω COUPLING CAPACITOR



The coupling capacitor is a short length of coaxial line having a disc capacitor (4700 pF, ±20%) in series with the inner conductor. Reflection ratio (in 150 ps tdr system), max is 0.03. Voltage rating is 200 V.

| | | |
|-------------------------------|-------------|----------|
| Coupling Capacitor SMA (3 mm) | 015-1013-00 | \$170.00 |
|-------------------------------|-------------|----------|

The coupling capacitor is a short length of coaxial line having a disc capacitor (4700 pF) in series with the inner connector. High frequencies are transmitted with small reflection, but dc and low frequencies are blocked. Voltage rating is 500 V.

| | | |
|-----------------------|-------------|---------|
| Coupling Capacitor GR | 017-0028-00 | \$90.00 |
|-----------------------|-------------|---------|

50 Ω POWER DIVIDERS



This coaxial tee is designed for use in broad-band 50 Ω systems where the mismatch introduced by ordinary "Tee" connectors is undesirable. Load isolation is nominally 6 dB while the voltage attenuation ratio is nominally 2X (input to either load arm, other load arm terminated in a standard 50 Ω termination). Max vswr is 1.50 from dc to 12.00 GHz and 1.90 from 12.01 to 18.00 GHz.

| | | |
|--------------------------|-------------|----------|
| Power Divider SMA (3 mm) | 015-1014-00 | \$200.00 |
|--------------------------|-------------|----------|



This coaxial tee has a 16.67 Ω resistor in each leg, connected so that the tee looks like 50 Ω if two legs are terminated in 50 Ω. It is designed for use in broad-band 50 Ω systems where the mismatch introduced by ordinary "Tee" connectors is undesirable. It is especially useful in a time-domain reflectometer set-up where test line, pulser, and oscilloscope must be coupled with a minimum of reflection-producing discontinuities.

| | | |
|------------------|-------------|----------|
| Power Divider GR | 017-0082-00 | \$225.00 |
|------------------|-------------|----------|

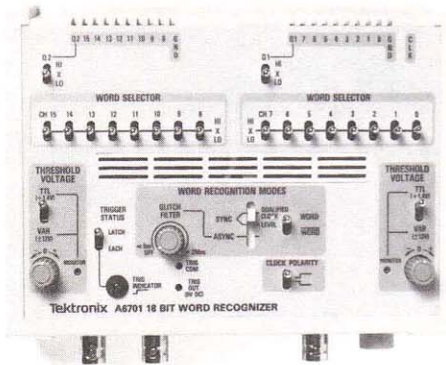

A6701 Word Recognizer

Gate Emulation: AND, NAND, OR, NOR

Expandable in 18 Bit Increments

1 to 18 Bits at 50 MHz Clock Rate

Up to 72 Bits @ 15 MHz Clock Rate

Accommodates all Logic Families

Synchronous Qualified Clock and Level Modes

Glitch Filter

The A6701 18 Bit Word Recognizer provides easy-to-use, uniquely configurable gate emulated triggering for digital troubleshooting. Besides conventional AND word recognition, the A6701 can be configured to provide NAND, OR, NOR or a combination of user-defined logic triggering. Both synchronous and asynchronous modes are provided along with such features as WORD-WORD selection, threshold voltage selection and glitch filter. In the synchronous mode, you may select either a level or qualified clock output.

CHARACTERISTICS CONTROL POD

Input RC — 1 M Ω paralleled by 5 pF.

Threshold Voltage —

TTL — Fixed at 1.4 V.

VAR — ± 12 V.

Minimum Input Swing — 500 mV p-p ($\pm 2\%$ of threshold voltage) or less centered about the threshold voltage.

Maximum Clock Rate — 1-18 channels—50 MHz.

Clock Input — Minimum clock pulse width 1-18 channels—10 ns high, 10 ns low.

P6401 Logic Probe

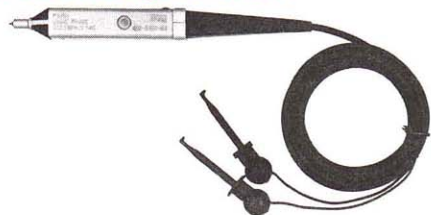

The small, lightweight, hand-held P6401 indicates the state of logic levels in TTL, DTL, or any other system with threshold between 0.7 and 2.15 volts. A strobe input can be used to detect the coincidence of logic signals at two points. An indication

Data and Qualifier Inputs —

SYNC QUALIFIED CLOCK or SYNC-LEVEL

MODE — 1-18 channels.

Minimum setup time — 16 ns or less.

Delay time for output to change states following the coincidence of a word pattern match and the selected clock edge — Max. 17.0 ns., typical 13.5 ns, min. 10.0 ns.

ASync-GLITCH FILTER OFF MODE — 1-18 channels.

Minimum input pulse width for ≥ 5 ns output — 10 ns or less, any single channel; 15 ns or less, any combination of channels.

Maximum input delay difference between channels — 7 ns.

Delay time from probe tip to trigger output connectors — Max 20.0 ns, typical 16.5 ns, min 10.0 ns.

SYNC-GLITCH FILTER ON MODE — Filter continuously variable from < 5 ns to > 250 ns.

Trigger Output (BNC and Trig Out Square-Pin) —

HI Level — ≥ 2.2 V (1.1 V into 50 Ω load).

LO Level — ≤ 0.6 V.

Output Impedance — 50 Ω .

Expansion Output —

Level — Standard ECL level terminated at expansion input of next module.

Delay from probe tip to expansion output BNC —

Max 19.5 ns, typical 15.5 ns, min 9.0 ns.



POWER SUPPLY

The separate power supply module can power two 18 Bit word recognizer pods.

Line voltage is selected by changing the line voltage selector card to operate on 115 V system or 230 V system.

Frequency — 48-440 Hz.

Maximum Power Consumption — 29 W.

Operating Temperature — 0°C to 50°C.

of whether a logic pulse has or has not occurred can be obtained in a "store" mode.

Power may be obtained from the unit under test or any 5 V supply.

Two bright lights in the probe tip indicate condition of the logic signal.

CHARACTERISTICS

Low State Input Voltage Range — 0 V to $+0.7$ V ± 0.125 V.

High State Input Voltage Range — 2.175 V ± 0.125 V to Vcc.

Minimum Recognizable Pulse Width — 10 ns.

Impedance — ≈ 7.5 k Ω paralleled by ≈ 6 pF.

Minimum Circuit Resistance for Open Circuit Indication — 10 k Ω .

PHYSICAL CHARACTERISTICS

| Dimensions | Word Recognizer Unit | | Power Supply Unit | |
|------------|----------------------|------|-------------------|-----|
| | cm | in | cm | in |
| Length | 16.3 | 6.5 | 20.0 | 8.0 |
| Height | 4.3 | 1.7 | 8.0 | 3.2 |
| Width | 11.9 | 4.75 | 15.0 | 6.0 |
| Weight | kg | lb | kg | lb |
| Net | 0.45 | 1.0 | 2.0 | 4.5 |



INCLUDED ACCESSORIES

| | |
|---------------------------------------|-------------|
| 1 Carrying Case (A) | 016-0451-00 |
| 1 Pouch, Accessory (B) | 016-0537-00 |
| 1 Cable Assembly, 50 Ω BNC (C) | 012-0482-00 |
| 1 Lead, Electrical (D) | 195-0277-00 |
| 21 Tip, Probe: Microcircuit Test (E) | 206-0222-00 |
| 1 Dc Power Cord (F) | 012-0848-00 |
| 2 Lead Set, 10-Wide (G) | 012-0747-00 |
| 1 Power Cord, 125 V ac | 161-0066-00 |
| 1 Fuse, 0.4 A Slow-Blow | 159-0031-00 |
| 1 Fuse, 0.2 A Slow-Blow | 159-0044-00 |

ORDERING INFORMATION

| | |
|--|---------------|
| A6701 18 Bit Word Recognizer (with accessories and power supply) | \$1485 |
| A6701 Option 01 18 Bit Word Recognizer (with accessories, without power supply) Note: Requires A6701 above for 36 bits parallel word recognition | Sub \$325 |
| 015-0356-00 Power Supply | \$375 |

OPTIONAL ACCESSORIES

| | |
|--|-------|
| 012-0800-00 P6451 to 10-Wide Connector | \$30 |
| 012-0209-00 Lead Set With Hook Tip, 40 CM (10 Leads) | \$315 |
| 012-0655-01 Lead Set, 40 CM (10 Leads) | \$40 |
| 012-0655-02 Lead Set, 20 CM (10 Leads) | \$70 |
| 015-0330-00 Dip Clip, Low Profile (16 Pin) | \$35 |
| 103-0209-00 P6451 to GPIB | \$180 |
| 015-0339-00 Dip Clip, Low profile (40 Pin) | \$40 |

Max Safe Input — ± 150 V (dc or RMS).

Minimum Recognizable Strobe Pulse Width — 20 ns.

Max Safe Strobe Input — ± 30 V (dc or RMS).

Strobe Input Impedance — 5.6 k Ω within 20%.

Order P6401 5 ft Probe (010-6401-01) \$135

Includes: Hook Tip (206-0114-00)
Strobe Lead (175-0958-01)
Strobe Lead (175-0958-00)
Probe Tip to 0.025 in square pin adapter (206-0137-01)
White Plug (348-0023-00)
2 Alligator Clips (344-0046-00)
Accessory Pouch (016-0537-00)

MOUNTING DIMENSIONS

| PRODUCT | H | | L | | F | | G | | E | | RF | | RR | | T | | C | |
|--------------------------------|------|------|------|------|------|-----|------|-----|------|------|------|------|------|------|------|------|------|------|
| | in | cm | in | cm | in | cm | in | cm | in | cm | in | cm | in | cm | in | cm | in | cm |
| R434 | 5.3 | 13.5 | 18.0 | 45.7 | 1.6 | 4.0 | — | — | — | — | — | — | — | — | — | — | 5.3 | 13.5 |
| R465B*, R475*, R-475A* | 7.0 | 17.8 | 16.3 | 41.4 | 1.8 | 4.6 | 3.5 | 8.9 | 20.4 | 51.8 | 11.0 | 27.9 | 7.9 | 20.1 | 9.6 | 24.4 | 6.8 | 17.3 |
| R485* | 7.0 | 17.8 | 16.2 | 41.1 | 1.8 | 4.6 | 3.5 | 8.9 | 19.3 | 49.0 | 10.9 | 27.7 | 7.9 | 20.1 | 9.3 | 23.6 | 6.8 | 17.3 |
| R491* | 7.0 | 17.8 | 17.4 | 44.2 | 2.1 | 5.1 | 3.5 | 8.9 | 21.1 | 53.6 | 11.9 | 30.2 | 8.5 | 21.6 | 9.3 | 23.6 | 6.8 | 17.3 |
| R5100N, R5400* | 5.3 | 13.5 | 19.0 | 48.3 | 1.1 | 2.8 | 1.8 | 4.6 | 24.6 | 62.5 | — | — | — | — | — | — | 5.3 | 13.5 |
| R7704* | 7.0 | 17.8 | 22.4 | 56.9 | 2.3 | 5.8 | 1.8 | 4.6 | 33.3 | 84.6 | 15.3 | 38.9 | 10.7 | 27.2 | 18.5 | 47.0 | 7.0 | 17.8 |
| R7313*, R7603*, R7613*, R7623* | 5.3 | 13.5 | 22.3 | 56.6 | 2.0 | 5.1 | — | — | 25.2 | 64.0 | — | — | — | — | — | — | 5.3 | 13.5 |
| R7844* | 7.0 | 17.8 | 24.8 | 56.6 | 2.3 | 5.8 | 1.75 | 4.4 | — | — | — | — | — | — | — | — | 7.0 | 17.8 |
| R7903* | 5.3 | 13.5 | 22.5 | 57.2 | 2.3 | 5.8 | — | — | 25.3 | 64.3 | — | — | — | — | — | — | 5.3 | 17.8 |
| R7912* | 5.3 | 13.5 | 26.9 | 68.3 | 1.8 | 4.6 | — | — | 26.9 | 68.3 | — | — | — | — | — | — | 5.3 | 13.5 |
| 7912AD | 7.0 | 17.8 | 26.0 | 66.0 | 1.95 | 5.0 | — | — | 30.7 | 78.0 | — | — | — | — | — | — | 6.9 | 17.5 |
| RTM506 | 5.25 | 13.3 | 18.9 | 48.0 | 1.82 | 4.7 | — | — | — | — | — | — | — | — | — | — | 5.25 | 13.3 |
| T922R | 5.2 | 13.2 | 17.0 | 43.2 | 1.7 | 4.3 | — | — | 24.2 | 61.5 | — | — | — | — | — | — | 5.2 | 13.2 |
| 016-0115-02 | 5.3 | 13.5 | 16.3 | 41.4 | 0.3 | 0.8 | — | — | — | — | — | — | — | — | — | — | 5.3 | 13.5 |
| 016-0268-00 | 5.3 | 13.5 | 19.8 | 50.3 | 1.8 | 4.6 | — | — | — | — | — | — | — | — | — | — | 5.2 | 13.2 |
| 040-0551-01 | 14.0 | 35.6 | 22.4 | 56.9 | 0.6 | 1.5 | — | — | 30.9 | 78.5 | — | — | — | — | — | — | — | — |
| 040-0554-01 | 15.8 | 40.1 | 21.5 | 54.6 | 1.9 | 4.8 | — | — | 31.3 | 79.5 | — | — | — | — | — | — | — | — |
| 040-0600-00 | 5.25 | 13.3 | 18.3 | 46.5 | 0.7 | 1.8 | — | — | — | — | — | — | — | — | — | — | 5.25 | 13.3 |
| 040-0601-00 | 5.25 | 13.3 | 18.3 | 46.5 | 0.7 | 1.8 | — | — | — | — | — | — | — | — | — | — | 5.3 | 13.5 |
| 040-0616-02 | 5.3 | 13.5 | 16.5 | 41.9 | 1.1 | 2.8 | 1.8 | 4.6 | 24.6 | 62.5 | — | — | — | — | — | — | 5.25 | 13.3 |
| 040-0617-02 | 5.3 | 13.5 | 16.5 | 41.9 | 1.1 | 2.8 | 1.8 | 4.6 | 24.6 | 62.5 | — | — | — | — | — | — | 5.3 | 13.5 |
| 040-0624-01 | 5.25 | 13.3 | 18.3 | 46.5 | 0.7 | 1.8 | — | — | — | — | — | — | — | — | — | — | 5.3 | 13.5 |
| 437-0031-00 | 8.8 | 22.4 | 9.5 | 24.1 | 0.3 | 0.8 | — | — | — | — | — | — | — | — | — | — | 5.25 | 13.3 |
| 437-0071-00 | 7.0 | 17.8 | 13.4 | 34.0 | 1.4 | 3.6 | — | — | — | — | — | — | — | — | — | — | 7.1 | 18.0 |
| 437-0126-01 | 5.3 | 13.5 | 22.3 | 56.6 | 2.0 | 5.1 | — | — | 25.2 | 64.0 | — | — | — | — | — | — | 6.6 | 16.8 |

*These instruments mount with sliding tracks to a standard 19-inch wide rack. Rear support for sliding tracks is required, such as an enclosed rack.

RACK ADAPTERS

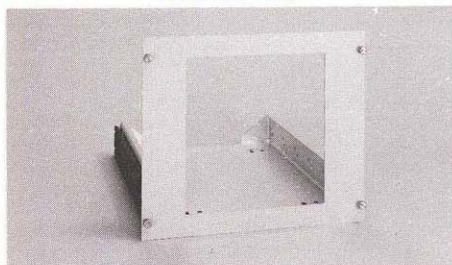

For rackmounting the 7000 Series Oscilloscopes in a standard 19 in wide rack. Rack adapter includes slide-out assemblies. 7000 Series mask finish is light gray.

For 7704A, 7104, 7834 and 7854, rack height is 15.75 in, rack depth is 21.38 in, shipping weight is ≈ 41 lb.

Order 040-0611-01 \$700

For 7704 and 7904, rack height is 15.75 in, rack depth is 21.75 in, shipping weight is ≈ 41 lb.

Order 040-0554-01 \$700

For 455 and 465M, includes cradle mount, rack height 7 in, rack depth 18.75 in.

Order 040-0825-01 \$320



For 468, and DM versions of other 400 Series Oscilloscopes.
Order 016-0675-00 \$300

STORAGE CABINETS

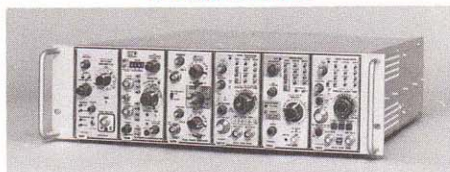

For 7000 Series Plug-in Units — Holds 6 plug-in units, for mounting in a 19 in rack, 5.25 in high.
Order 437-0126-03 \$680

REAR-SUPPORT CRADLES

Provide rear support for rackmount instruments with slide-out assemblies, when mounted in a 19 in backless rack. Shipping weight is ≈ 3 lb.

For R561B, R564B, and R647A.

Order 040-0344-00 \$45

CRADLE MOUNTS

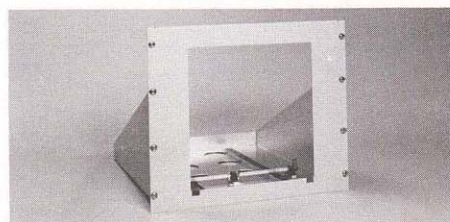

For rackmounting 7000 Series cabinet-type oscilloscopes in a standard 19 in wide rack. Cradle mount consists of a cradle (or "shelf") without slide-out assemblies and a mask to fit over the regular instrument panel. 7000 Series mask finish is light gray.

For 7704A, rack height is 15.75 in, rack depth is 22 in, shipping weight is ≈ 16 lb.

Order 040-0560-00 \$385

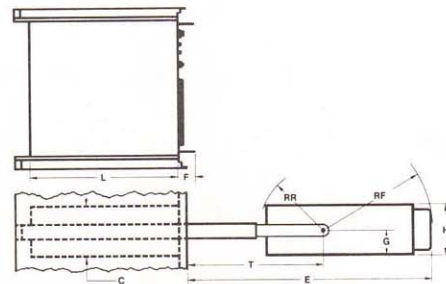

DIMENSIONS EXCLUSIVE OF PLUG-IN UNITS AND PROBES

| Symbol | Definition |
|--------|---|
| H | Height of front panel. |
| L | Rack front to rearmost permanent fixture excluding cables. |
| F | Back of front panel to foremost protrusion. |
| G | Bottom of front panel to horizontal plane of rotation. |
| E | Maximum forward clearance with instrument out and horizontal. |
| RF | Front radius of rotation. |
| RR | Rear radius of rotation. |
| T | Rack front to pivot point. |
| C | Cabinet height. |

BLANK PANEL

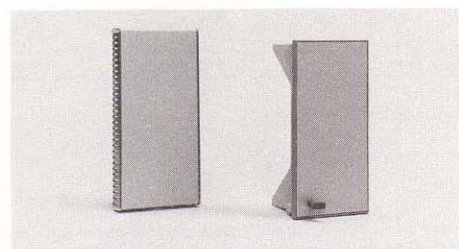

Blank Panel — When operating the 5000/7000 Series Mainframes or the TM 500 or 2600 Series Generators with less than a full complement of plug-ins, the blank panel may be used to cover an unused compartment. The panel for the 7000 Series is also good for EMC Shielding.

7000 Series, 2600 Series, Order 016-0155-00 \$40

5000 Series, Order 016-0452-00 \$15

TM 500 Series, Order 016-0195-03 \$21

BLANK PLUG-IN CHASSIS

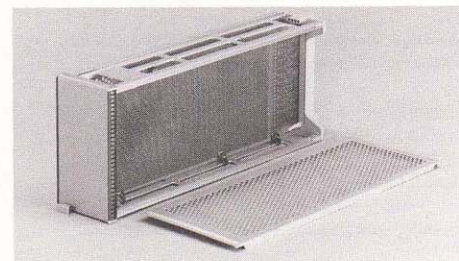

Blank Plug-in Chassis — Available for all Tektronix Mainframes. The 7000 Series provides a printed circuit board, plug-in frame, and securing hardware. The 560 Series, 1-Series, and Letter Series plug-in chassis have an interconnecting plug, securing hardware and plug-in frame.

7000 Series, Order 040-0553-01 \$130

5000 Series, Order 040-0818-03 \$105

TM 500 Series, Order 040-0652-05 \$75

560 Series, Order 040-0245-00 \$125

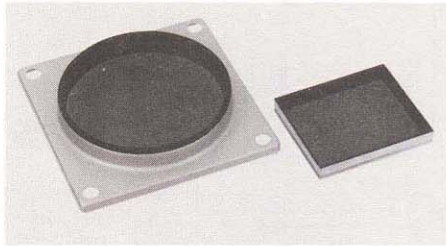

CRT MESH FILTERS

The mesh filter improves display contrast for oscilloscope viewing under high ambient light conditions.

A fine metal screen with a matte black surface is utilized to reduce light reflections. Although light transmission from the CRT is reduced to approximately 28%, the high attenuation of external reflections allows viewing low-intensity displays in room light or other bright surroundings.

The mesh filter also serves as an emc filter. Installed on the instrument, the metal frame of the filter is grounded, providing effective filtering of the emc spectrum.

| INSTRUMENT* | PART NUMBER | PRICE |
|--|-------------|-------|
| 314, 326, 335 | 378-0063-00 | \$27 |
| 432, 434 | 378-0682-00 | \$33 |
| 422, 491, 453A, 454A, 485 | 378-0648-00 | \$22 |
| 465, 465B, 475, 464, 466, 434 | 378-0726-01 | \$45 |
| 7400, 7603 | 378-0696-00 | \$50 |
| 7500, 7700, 7800, 7900 Series and 7613, 7623 | 378-0600-00 | \$50 |

*For both cabinet and rackmount instruments.

VIEWING ACCESSORIES

The viewing accessories listed normally mount on the oscilloscope graticule cover. In many cases, they will also fit camera-mounting bezels. If you intend using a camera on your oscilloscope, check with your Tektronix Sales Engineer for bezel-viewer compatibility before ordering.

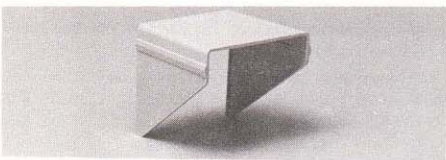

View Hood (folding) — 314, 326, 335, 400 Series, 576, 577, 5000, and 7000 Series Oscilloscopes.

| | |
|---|---------|
| For 576, Order 016-0259-00 | \$16 |
| For 577, 5000, and 7000 Series | |
| Order 016-0260-00 | \$15 |
| For 326, 314, 335, SC 502, SC 504 (not pictured), | |
| Order 016-0297-00 | \$ 6.50 |
| For 464, 466, 455 (not pictured), | |
| Order 016-0592-00 | \$12 |



Polarized Viewers — For Tektronix older 5 inch oscilloscopes. The viewers reduce troublesome reflections and glare under high ambient light conditions.

Rectangular Viewer, order 016-0039-00 \$60
Plastic Round Viewer, order 016-0053-00 \$38

Viewing Hood — For Tektronix older 5 inch round oscilloscopes. Includes molded rubber eyepiece and separate tubular light shield.

Order 016-0001-01 \$100

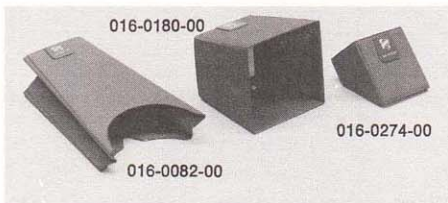

Collapsible Viewing Hood — For oscilloscopes with rectangular CRTs. Blue vinyl material, folds flat for convenient storage.

For 422, 453A, 454A, 485, 491, order 016-0082-00 \$15

For 422, 453A, 454A, 485, 491, order 016-0274-00 \$15

Viewing Hood (folding binocular) — For some 400 Series. For 434, 455, 464, 466, 465B, 475 and 475A.

Order 016-0566-00 \$15

Polarized Collapsible Viewing Hood — To reduce reflections and glare under high ambient light conditions for 432, 434, 455, 465, 465B, 475, 464, 466, order 016-0180-00 \$40

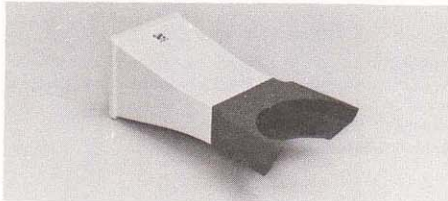

Viewing Hood — For 576, 5000 and 7000 Series oscilloscopes. Molded gray polystyrene with polyurethane eyepiece.

For 576, order 016-0153-00 \$35
For 5000 and 700 Series, 601, 602, 603, 604, 528 and 577, order 016-0154-00 \$22

CATHODE-RAY TUBE LIGHT FILTERS

| INSTRUMENT* | COLOR | PART NUMBER | PRICE |
|------------------------------------|------------------------|-------------|--------|
| 314, 335 | Blue | 378-2016-01 | \$1.80 |
| 200 Series | Blue | 378-0691-00 | 1.10 |
| 455 | Blue | 337-2122-00 | 4.15 |
| 465, 465B, 475, 464, 466 | Blue | 337-1674-00 | 4.00 |
| | Clear | 337-1674-01 | 4.00 |
| | Smoke-gray filter | 337-1674-07 | 4.00 |
| 540, 550 Series | Smoke-gray† | 378-0567-00 | 7.00 |
| 565, 575 | Green | 378-0568-00 | 4.00 |
| | Blue | 378-0569-00 | 4.00 |
| | Amber | 378-0570-00 | 4.00 |
| 529, 561B, 567 568 | Smoke-gray† | 378-0560-00 | 4.00 |
| 576 | Blue† | 378-0616-00 | 3.85 |
| | Amber | 378-0616-01 | 5.00 |
| 603, 604 | Clear (603†) | 337-1440-00 | 2.50 |
| | Green | 337-1440-01 | 2.80 |
| | Amber | 337-1440-02 | 3.50 |
| | Blue | 337-1440-03 | 3.50 |
| | Gray | 337-1440-04 | 4.50 |
| | Graticule | 331-0303-00 | 5.00 |
| 605, 606, 607 | Blue | 337-1674-00 | 4.00 |
| | Amber | 337-1674-05 | 5.00 |
| | Graticule | 337-1674-10 | 5.00 |
| | Clear Shield | 337-1674-13 | 5.00 |
| | Gray† | 337-1674-06 | 4.00 |
| | Graticule | 331-0391-00 | 4.00 |
| 608 | Amber | 378-0704-00 | 5.00 |
| | Green | 378-0705-00 | 5.00 |
| | Graticule† | 337-2126-02 | 8.00 |
| 7904, 7844 | Blue† | 378-0625-00 | 3.50 |
| 7313, 7700 | Amber | 378-0625-01 | 4.00 |
| Series, 7613 | Gray | 378-0625-02 | 3.50 |
| 7623 | Green | 378-0625-03 | 3.75 |
| | Gray Tv Graticule | | |
| | CCIR | 378-0625-05 | 5.00 |
| | Gray Tv Graticule | | |
| | NTSC | 378-0625-06 | 8.25 |
| | Clear Shield | | |
| | With Spectrum Analyzer | | |
| | Graticule | 337-1159-02 | 6.50 |
| 7613, 7623 | Spectrum | | |
| 7623A, 7633 | Analyzer | 378-0625-07 | 8.25 |
| | Green (UV) | 378-0625-08 | 4.50 |
| | Tv Graticule | | |
| | CCIR | 378-0625-09 | 9.25 |
| | Tv Graticule | | |
| | NTSC | 378-0625-10 | 9.25 |
| 7403N, 7603 | Blue | 378-0684-00 | 5.00 |
| | Amber | 378-0684-01 | 7.00 |
| | Gray | 378-0684-02 | 4.20 |
| | Green | 378-0684-03 | 5.75 |
| | Gray Tv Graticule | | |
| | CCIR | 378-0684-04 | 10.00 |
| | Gray Tv Graticule | | |
| | NTSC | 378-0684-05 | 10.00 |
| | With Spectrum Analyzer | | |
| | Graticule | 337-1439-01 | 8.00 |
| | Blue Implosion Shield† | 337-1700-01 | 6.50 |
| | Clear Implosion Shield | 337-1700-04 | 6.50 |
| 5100 and 5400 Series (except 5441) | Clear | 337-1440-00 | 2.50 |
| | Green | 337-1440-01 | 2.80 |
| | Amber | 337-1440-02 | 3.50 |
| | Blue | 337-1440-03 | 3.50 |
| | Gray | 337-1440-04 | 4.50 |
| 5441 | Clear† | 337-1674-01 | 4.00 |
| | Gray | 337-1674-06 | 4.00 |
| | Graticule | 331-0391-00 | 4.00 |
| | (8x10 div) | | |
| 434 | Blue | 378-0678-01 | 1.50 |

*For both cabinet and rackmount instruments unless rackmount version is listed.

†Standard filter supplied with instrument.

CUSTOMER INFORMATION

CONTENTS

| | |
|------------------------------|-----|
| Ordering Information | 351 |
| Service Network | 352 |
| Maintenance Agreements | 352 |
| Repair Parts | 352 |
| Provisioning | 353 |
| Maintenance Training | 353 |
| Service Publications | 353 |
| Product Operation | 354 |
| Product Applications | 354 |
| Tekscope | 354 |
| OEM Information | 354 |
| Warranty | 355 |
| Terms of Sale | 356 |
| Functional Index | 357 |
| Alphanumeric Index | 362 |

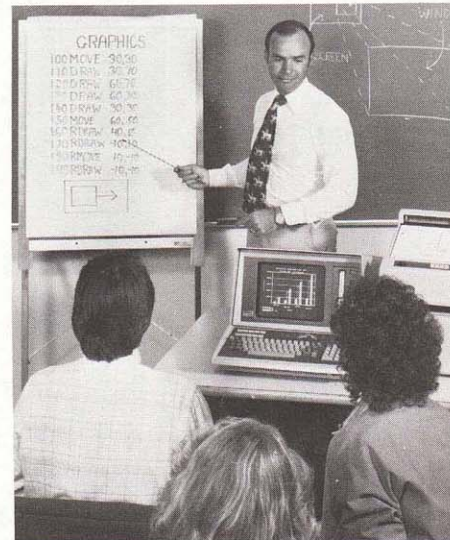

When you buy a Tektronix product, you are buying more than an oscilloscope ... or a computer terminal ... or a logic analyzer... or any of our numerous test and measurement products. You are also investing in the many people and services behind your Tektronix product.

A staff of Customer Service Representatives serves as your initial interface with the company.

Trained Sales Engineers give you expert service advice and after-the-sale support.

A network of service centers throughout the U.S. and most other parts of the world provides speedy and competent calibration, maintenance, and repair service.

The long term support program insures years of service after a product is removed from the production line.

The training and support program offers classes in Tektronix product theory, operation, maintenance, and repair at our main plant in Beaverton, Oregon and at various locations throughout the world. Audio and video training tapes are also available.

Each of these services adds value to your Tektronix product.

Sales Engineers

Your Sales Engineers are fully prepared to respond to your technical and business requirements. They have a strong technical background and extensive product and business training. Periodic refresher courses fully acquaint them with new products and services. Be sure to take advantage of their services.

Communications

Your Sales Engineers are a valuable communication link between you and the factory. They know the exact person to contact in each circumstance, and can reach that person fast and easily. Let them help your communications on any problem related to your Tektronix products.

Ordering

There are many types of products, each designed for a specific application area. Your Sales Engineer can help you select the one best suited to your present and future needs, and will be happy to arrange a demonstration of the product ... in your application if you so desire.

If you are a Purchasing Agent or Buyer, your Sales Engineer or Customer Service Representative can provide information on prices, terms, shipping estimates, and best method of transportation on Tektronix products, accessories and replacement parts.

YOUR TEKTRONIX WORLDWIDE SERVICE NETWORK

With every Tektronix product comes a long-term commitment to professional service, extending far beyond your warranty period. We seek to establish a working partnership to best meet your requirements, at the time of purchase and in the years to come. No product is shipped until service support is solidly in place.

We offer a worldwide service network with the technical back-up and total company resources to keep your Tektronix products running as reliably as the day they're installed. Local accessibility is offered by 85 Service Centers and Tektronix supported service technicians in over 50 countries (see page 366-368 for specific locations). Some 1,400 people around the world are dedicated to servicing Tektronix products exclusively.

Training programs, service bulletins and our own diagnostic tools all contribute towards making our service people among the most highly skilled in the world.

Today's business demands put a higher-than-ever requirement on equipment uptime. You can depend on Tektronix for the technical expertise, extensive inventory and prompt response that make us your best choice and, at bottom line, your best value in long-term service support. It's our business keeping yours on-line.

For more detailed information please use the reply card in the center of your catalog.

Maintenance Agreements

A Tektronix Maintenance Agreement provides a planned program of regular service that protects the continuity of your product's operation--and paves the way for the fastest, most effective response to unplanned downtime. A Maintenance Agreement assures you of priority service, be it an emergency situation or otherwise.

One agreement covers all scheduled inspections, repairs, replacement parts, adjustments, and labor costs. Required product updates are installed automatically,



keeping your product in top condition. You can confidently plan maintenance programs and budgets without facing open-ended service charges later. Additionally, a Tektronix Maintenance Agreement eliminates special training costs for your own maintenance personnel, as well as expensive service equipment, spare parts and special tools. It's everything you need within a low, fixed fee.

We also offer several other types of Service Programs. A Tektronix Service Representative can help tailor one to the requirements of your operation.

Time and Material Service

Factory-trained technicians are standing ready to repair and calibrate, or recondition and overhaul your Tektronix instruments.

Marginal components and worn parts are replaced and required updates installed. All qualified calibration measurements meet MIL spec requirements traceable to National Standards. Pick-up and delivery is available at selected locations. And, on-site service is offered for information display products, microprocessor development, signal processing and semiconductor test systems.

For service, replacement parts, answers to warranty questions, or other help, please notify the Tektronix facility nearest you. Please do not return instruments or parts before receiving directions.

Repair Parts

In support of its self-maintenance customers, Tektronix maintains over \$40 million in available parts, from components to assembly level. Our objective is to be able to provide you the right part in the right place at the right time. In addition to on-hand inventory, we have a special manufacturing operation that builds replacement parts for discontinued items.

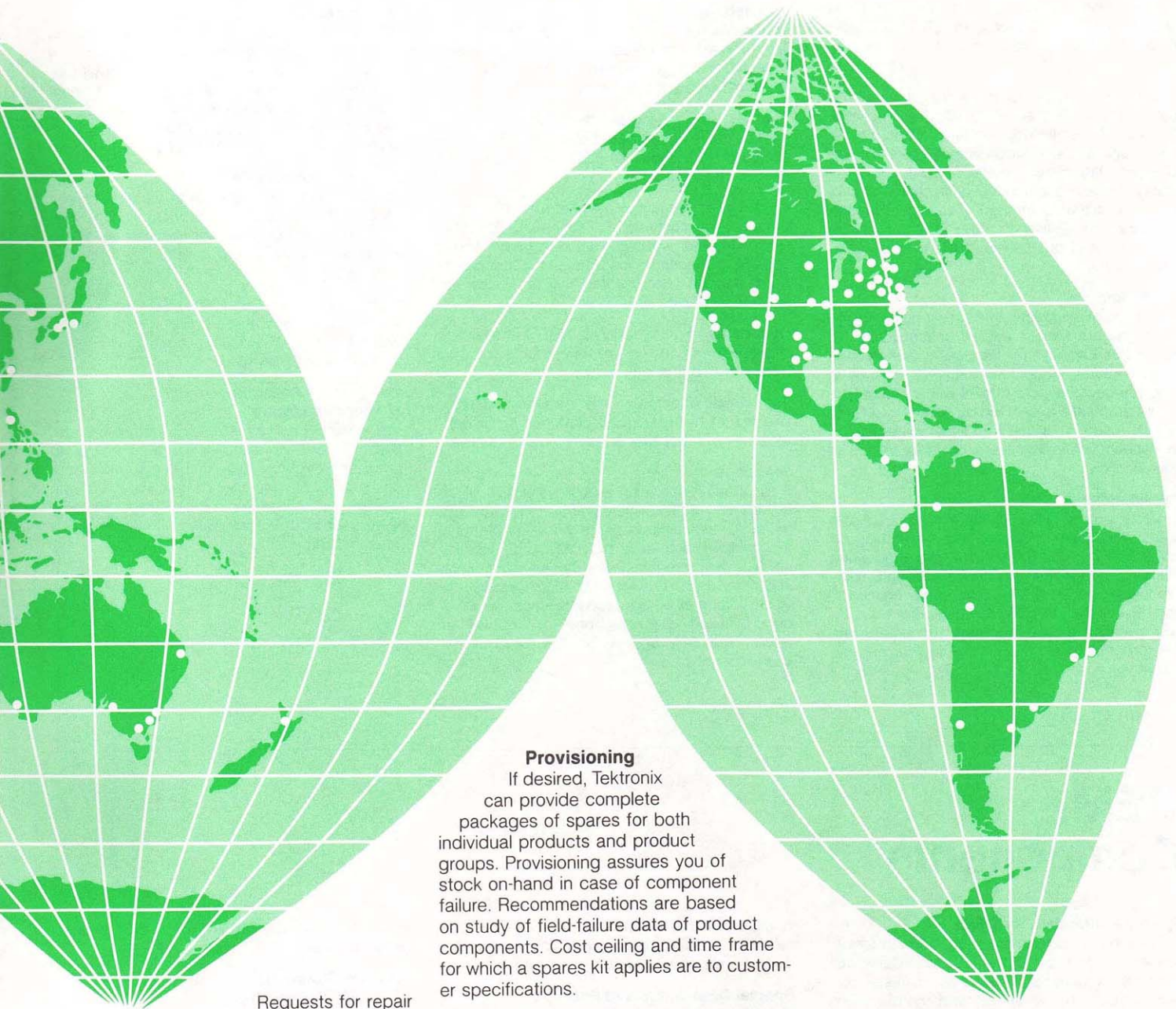

Requests for repair and replacement parts should be directed to your nearest Tektronix Sales/Service Office, with product type number and serial number included for fastest possible service.

Module Repair and Return

Tektronix factory service offers a convenient, cost-effective means for many customers to obtain repairs on specified modules for information display products, microprocessor development, signal processing and semiconductor test systems. Modules are sent to our Beaverton repair facility, repaired and returned promptly. Our module repair center offers good turn around, helping maximize customer uptime.

Provisioning

If desired, Tektronix can provide complete packages of spares for both individual products and product groups. Provisioning assures you of stock on-hand in case of component failure. Recommendations are based on study of field-failure data of product components. Cost ceiling and time frame for which a spares kit applies are to customer specifications.

Maintenance Training

Tektronix has established a comprehensive Customer Maintenance Training Program designed to enhance the value of our products as long-term investments.

Formal classroom training is offered at Tektronix Industrial Park in Beaverton, Oregon, in Amstelveen, Holland and at a number of field locations throughout the world.

We also offer audiotapes on operation, circuit description and calibration; videotapes covering basic concepts, operation and applications; and multi-media training packages that incorporates printed material, audiotapes and videotapes for independent study.

Information

regarding these training opportunities is available from your nearest Tektronix Sales/Service Office, including course descriptions, class schedules and tuition details. You may also request a copy of the Tek Customer Training Catalog on the return card in the center of this catalog.

Service Publications

Service manuals, available for every Tektronix instrument, contain circuit schematics, parts lists, operating, maintenance and troubleshooting information.

TEKNOTES (an English only publication) is a periodic newsletter with information about

product modifications, new service procedures and maintenance functions. Your Tektronix Sales Representative can place your name on its mailing list.

In addition, service information is available to customers on ANSI standard 105x148 mm negative microfiche. Included in a product maintenance set are operator/service manuals, manual changes, data sheets, reference cards and information regarding product modifications. A subscription, available through your local Tektronix Sales/Service Office, includes a basic set of microfiche and quarterly updates to keep information current.

Operation

Your Tektronix product can be most useful to you when you are familiar with all control functions. Your Sales Engineer will be glad to demonstrate the use of your product in various applications to help you become more familiar with its operation. If your product is to be used by several engineers or other users, your Sales Engineer will be happy to conduct informal classes on its operation in your location.

Applications

To assist you with in-depth knowledge of specific areas, your Sales Engineers are backed up by specialists in such fields as: Signal Processing Systems, Television Products, Information Display Products, Spectrum Analyzers, Logic Analyzers, and Microcomputer Development Products. At your request, they will arrange to demonstrate Tektronix instruments for you — in your application, if you wish.

Traceability

The reference standards of measurement of Tektronix are compared with the U.S. National Standards through frequent tests by the U.S. National Bureau of Standards.

The Tektronix working standards and testing apparatus used are calibrated against the reference standards in a rigorously maintained program of measurement control.

The manufacture and final calibration of Tektronix products are controlled by the use of Tektronix reference and working standards and testing apparatus in accordance with established procedures and with documented results. (Reference MIL-STD-45662A)

Certificates of traceability to NBS are available with new products, as well as products you may have serviced at a later date.

A certificate of compliance stating that a particular product being shipped conforms to its published (or quoted) specification is also available.

Tekscope

A quarterly publication whose objective is to provide informative, timely articles presented in a readable manner across the whole of Tektronix technology. Each issue of TEKSCOPE contains articles describing instruments, measurements, and techniques. The New Products section provides information on products recently introduced, including photos, brief descriptions of unique features, and major specifications for each product.

International Service

Tektronix products are serviced in all countries where they're locally sold. Conditions within a country may limit the type of service available; therefore, some of the programs discussed here are not available in all countries. Specific country service capability can be obtained from your local Tektronix Sales or Distributors Office.

A Quality Partnership

The advantages of working with Tektronix extend far beyond our excellence in products. You also get a long-term commitment to professional service. All-out support backs designed-in performance.

Your local Tektronix Service Representative can tell you more about those services by which you can best benefit and profit from your working partnership with Tektronix.

Our Product Reliability Is Your Foundation

Any system is only as reliable as the components that go into it. At Tektronix, we're committed to producing the most dependable system components possible. You can be confident that the reliability we design into our equipment can help keep your customers satisfied. That's reliability you can build on.

OEM Components

Special Information for OEMs

At Tektronix we offer many products with terms, conditions, and pricing for OEMs. Computer graphics components, small screen displays, certain cameras, tv signal test and measurement instrumentation — we offer these and other products on a special basis to the original equipment manufacturer.

But terms and conditions tell only part of the Tektronix OEM story. Our products have the quality, reliability, and the top performance per dollar that the OEM needs to stay competitive.

Choose The Performance Level To Match Your System

In many product areas our wide range of OEM components allows you to select just the optimal performance you need for the system you are building. When your systems demand highest performance, Tektronix will provide the quality products to meet your standards.

In price-sensitive situations, the wide Tektronix selection usually lets you pay for exactly the performance level you need — no more, no less.

Special OEM Terms and Pricing Help Keep You Competitive

Within the range of OEM components, we offer a variety of different OEM pricing arrangements and terms. Ask your local Tektronix representative about the special OEM terms and pricing available to you.

Service and Support — When and Where You Need It

Tektronix has service centers throughout the U.S. and in many countries around the world. We offer long term parts support to protect your investment.

If you need applications assistance, we're ready to help. Our OEM specialists are trained to help

solve interface problems. That's solid support when you need it.

You and Tektronix: A Quality Partnership

Explore the advantages of working with Tektronix: excellence in products, in support, and in service.

Your local Tektronix representative can help you get full details on how you can profit from a quality partnership with Tektronix.

See how our OEM expertise can add value to your system.

CORPORATE WARRANTY

Tektronix warrants that the products that it manufactures and sells or leases are free from defects in materials and workmanship. If any product that is manufactured and sold or leased by Tektronix fails to operate properly during the applicable warranty period as a result of a defect in materials or workmanship, Tektronix, at its option, either will repair the defective product and restore it to its normal operation without charge for parts and labor or will provide a replacement in exchange for the defective product.

In order to obtain service under the terms of the warranty, the customer must notify Tektronix of any defects before the expiration of the warranty period and make suitable arrangements for the performance of service.

Tektronix will provide on-site service under the terms of its warranty without additional charge on products installed by Tektronix and certain other designated products if the service is performed within the normal on-site service area. Tektronix will provide on-site service outside this area only upon prior agreement and upon payment of all travel expenses by the customer. In all other cases, the customer shall be responsible for packaging and shipping the products to the designated Tektronix Service Center, with shipping charges prepaid. Tektronix shall pay for the return of any products to the customer if the shipment is to a location within the country in which the Service Center is located. The customer shall be responsible for paying all shipping charges, duties, taxes, etc., for products returned to any other locations.

| Product Categories | Warranty Service Provided |
|--|--|
| Test and Measurement Type Products: Oscilloscopes and Plug-Ins; General Purpose Instruments; Data Communications Analyzers; Logic Analyzers; Spectrum Analyzers; Television Products (except ANSWER System). | Parts and labor at Service Center for 1 year from date of shipment. |
| Cameras, Carts, and Probes | Parts and labor at Service Center for 1 year from date of shipment. |
| Cathode Ray Tubes | CRTS at Service Center for 1 year from date of shipment. |
| Computer Graphics Products; Microcomputer Development Products; ANSWER System | Parts and labor on site for 90 days from date of shipment. |
| Signal Processing Systems; Semi-conductor Test Systems; 4081 Graphics System | Parts and labor on-site for 90 days from date of installation or 120 days from date of shipment, whichever is shorter. |

The applicable warranty periods and the warranty service provided for different categories of products are shown in the table.

The foregoing warranty shall not apply to any damage or defects caused by improper use or improper or inadequate maintenance and care. Tektronix shall not be obligated to furnish service under the warranty a) to repair damage resulting from attempts by personnel other than Tektronix representatives to install, repair or service the product; b) to repair damage resulting from improper use or from connecting the product to incompatible equipment; or c) to service a product that has been modified or integrated with other products not covered by a Tektronix warranty when the result increases the time or difficulty of servicing the product or increases the likelihood of damage to the product.

For information on the warranty period for any specific product and for further details regarding Tektronix warranties and service policies, please consult your local sales office. A complete statement of Tektronix' warranty for specific products will be supplied at the time of sale or upon request.

The warranty statement supplied at the time of sale is the exclusive warranty and is given in lieu of any other warranty express or implied. Tektronix explicitly disclaims any implied warranties of merchantability and fitness for a particular purpose.

Tektronix' responsibility to repair or replace defective products is the sole and exclusive remedy provided to the customer for breach of any warranty. Tektronix will not be liable for any direct, indirect, special, incidental or consequential damages.

Orders should be placed with your Tektronix Office listed on page 368.

Tektronix, Inc. offers many different terms of sale in order to meet varied purchasing objectives and to assist in financial planning. Any of the following terms may be arranged with a Tektronix Sales Engineer.

NET 30 DAYS

Tektronix, Inc. standard terms of sale are NET 30 days following the date of shipment. As with all credit terms, satisfactory credit accommodations must be arranged.

EXTENDED TERMS OF SALE

Extended terms of 60 to 180 days are available on the same single payment basis as standard terms. Since the cost of extended terms is not included in catalog prices, a service charge is added to the invoice. The amount of the service charge depends upon the number of days the terms are extended.

SECURITY AGREEMENT

This program provides monthly installment payment terms while Tektronix products are in use. Accessories and parts are not available unless they are associated with the products being purchased. New and used products may be purchased with a deduction for applicable quantity discounts.

A minimum advance payment equal to approximately 10% of the purchase price of the equipment desired is required for a Security Agreement. Installment terms covering the balance of the contract price are available for 6, 12, 18, 24, 30, or 36 months.

Minimum balance amounts may be financed, ranging from \$200 for six months to \$2000 for thirty-six months. Longer terms of 48 to 60 months are available by quotation for financed balances of more than \$10,000. There are no maximum finance balances.

All products carry the standard Tektronix, Inc. warranty. The customer is responsible for the equipment and applicable property taxes, licenses, etc. Upon completion of the term of agreement and prescribed payments, the customer owns the equipment.

COMPUTER GRAPHIC PRODUCTS

Most Computer Graphic Products are available under an *operating lease program*. The minimum fixed terms of this program are 12, 24, 36 months, or longer. Automatic extension on a month-to-month basis is also available after the fixed minimum term. Equipment leased on this program is maintained by Tektronix, Inc. during the terms of the agreement. Rental of Computer Graphic Products for customer evaluation is available for periods of 90 or more days.

During the term of the operating leases or rentals described, the customer may exercise an option to purchase the equipment provided 30 days notice is given. A portion of the installments already paid will be credited toward the purchase price. Questions regarding warranty should be discussed with your Tektronix Sales Engineer.

SHIPMENT

All prices, quotations, and shipments are FOB Beaverton, Oregon, unless otherwise specified.

Unless otherwise specified, shipment will be made via most economical method. Surface and air shipments will be insured at full valuation unless your order instructs otherwise.

Specification and price change privileges reserved.

A to D Converters 198

Accessory Power Supply 327

Accessories, Spectrum Analyzer 134

Accessories, TM 500 298-300

Ac RMS Digital Voltmeter 254-257

Adapters

BNC 346

BSM 346

Camera 319

Curve Tracer 310

F 347

GR 346, 347

N 347

SMA (3 mm) 347

Probe 338, 339

Probe Grounding 338

Rack 349

Air Line, GR 346

Alphanumeric Terminals 68-76

Amplifiers

Bandpass Filter/Amplifier 278

CATV Preamp 133

Current Probe 277, 329

Differential 187, 218, 219, 278

Differential Comparator 186, 218

Dual-Trace 185, 188, 201, 212, 217, 219, 221

Four-Trace 216

Programmable 182-185

Operational 278

Single-Trace 184, 186, 188, 199, 200, 216

Waveform Digitizer 217

Analyzers

Data 43-66, 56, 57

Data Communications Analyzers 26-35

Logic 43-66

Spectrum 118-134

APL Terminals 72,73

ATB, Spectrum Analysis 122

Attenuators

BNC 347

GR 347

N 347

SMA (3 mm) 347

Step 133

Audio Analyzer 284

Automated Test Equipment 36-42,143-147,252-295

Automatic Video Corrector *

Automatic Video Measurement Set 115

Bandpass Filter/Amplifier 278

Battery-Operated Oscilloscopes 222-249

Battery Power Supply 231, 235, 299

Blank Plug-in Chassis, Panel 349

BNC, Accessories with BNC Connectors 346

BSM, Accessories with BSM Connectors 346

Cabinets, Plug-in Storage 349

Cable Testing

Fault-Locating 116, 117

Time-Domain Reflectometer 116, 117, 200

Cables

BNC 346

BSM 346

GR 346

N 346

SMA (3 mm) 346

Calibration Generators 279-283

Camera Carrying Cases 321

Camera Mounting Adapters 319

Cameras, Oscilloscope 320-323

Carts, Lab and Rack 344, 345

CATV Preamp 133

Chassis, Blank Plug-in 349

Color Television Picture Monitor 104, 105

Communications Test Equipment

Automatic Video Measurement Set 115*

Cable Fault-Locators 116, 117

Demodulators 110

Frequency Counters 258-264

Noise Measurement Set 284

Ramp Generators 276

Sideband Analyzer 133

Spectrum Analyzers 118-134

Sweep, Audio Generator 285

Test Signal Generators 111, 113, 112*

TV Oscilloscopes 193, 232, 241, 242, 244

Vectorscopes 108, 109*

VITS Inserters *

Waveform Monitors 106, 107*

Computer Graphic Products

Computer Display 99-101

Display Terminals 67-78

Graphic Computer Terminal 68-76

Graphic Systems 79-83

Hard Copy Units 88-90

Interactive Digital Plotter 85-87

Interactive Graphic Units 68-81

Storage Display Monitors 94-100

Copiers 88-90

Cords, Patch 346, 347

Correctors, TV Signal *

Counters, Universal 196, 258-264

Counters, Time Interval 196, 258-264

Counters, Frequency 196, 258-264

Coupling Capacitor, GR 347

Coupling Capacitor, SMA (3 mm) 347

Covers, Protective 344

Cradle Mount 349

CRT Light Filters 350

CRT Mesh Filters 350

CRT Readout Oscilloscopes 155-165, 210, 211

CRT Readout Plug-In 204

Current Measuring Equipment 198, 218, 255, 257, 258, 277, 329, 331

Current Probe Amplifier 277, 329

Current Probes 277, 329-331

Curve Tracers, Semiconductor 301-309

D to A Converters *

*Contact your nearest Tektronix office or use the return card for more information.

| | |
|---|---|
| Data Acquisition Probes | 66 |
| Data Acquisition System | 143-147 |
| Data Analyzer | 43-66 |
| Data Communication Tester | 26-35 |
| Delayed Sweep Oscilloscopes | 155-178,208-215,222-245 |
| Delayed Sweep Sampling Plug-in | 201,221 |
| Demodulators, Television | 110 |
| Desktop Computer-Based Systems | 79-83,147 |
| Differential Amplifiers | 187,218,219,278 |
| Differential Comparator Amplifiers | 186,218 |
| Differential Probe | 328,336 |
| Digital Counters | 196,258-264 |
| Digital Delay | 55,195,267 |
| Digital Development Instruments | 43-66 |
| Digital Input Output Card | 290 |
| Digital Latches | 267 |
| Digital Multimeters | 198,232,254-257 |
| Oscilloscope Coupled w/Temp..... | 198,232 |
| DMM Oscilloscope..... | 198,224,232,237,239 |
| Digital Photometer/Radiometer | 311-314 |
| Digital Plotters | 85-87 |
| Digitizing Oscilloscopes | 176-182,208,209,242,243 |
| Digital Readout Oscilloscopes | 155-165,168-175,205-211 |
| Digital Servicing Aids | 35,56,267,348 |
| Digital Storage Oscilloscopes | 177,178,208,209,242,243 |
| Digital Storage Spectrum Analyzer | 126-128 |
| Digital Service Instrument | 35,56,58,59 |
| Digital Tester | 26-35 |
| Digitizer, Programmable | 176-182 |
| Digitizer Storage Oscilloscope | 176-178,208,209,242,243 |
| Disc Storage Memory | 84,92 |
| Display Formatter | 63,64 |
| Display Units | |
| Color Monitors..... | 102-105 |
| Nonstorage..... | 97,98 |
| Raster Scan..... | 96 |
| Storage..... | 99-101 |
| Distortion Analyzer | 284 |
| Dual-Beam Oscilloscopes | 160,215 |
| Dual-Trace Amplifiers | 185,188,201,212,217,219,221 |
| Dual-Trace Differential Oscill. Amp | 219 |
| Dual-Trace Oscilloscopes | 155-181,205-215,222-237,240-251,286-288 |
| Events Delay | 267 |
| Fault Locator, Cable | 116,117,200 |
| FET Probes | 327 |
| Filters | |
| Bandpass/Amplifier..... | 278 |
| Light..... | 350 |
| Mesh..... | 350 |
| Formatters, Display | 63,64 |
| Four-Trace Amplifiers | 216 |
| Frame, Mounting | 349 |
| Frequency Counter | 196,258-264 |
| Function Card | 290 |
| Function Generator | 272-276 |
| Generators, Signal | |
| Constant Amplitude..... | 282 |
| Fast Rise Pulse..... | 201-203,270,271 |
| Function..... | 272-276 |
| High Frequency..... | 270,271 |
| NTSC..... | 112,113 |
| PAL and PAL-M..... | 112,113 |
| Pulse..... | 201,268-271 |
| Ramp..... | 272-276 |
| Rate/Ramp..... | 275,276 |
| RC Oscillator..... | 283,285 |
| SECAM..... | 111 |
| Sinewave..... | 276 |
| Squarewave..... | 276 |
| Television Test Signal..... | 111-113 |
| Time-Mark..... | 282 |
| Tracking..... | 132 |
| Triangle..... | 275,276 |
| GPIB Products | 2-9,44-55,78-80,118-125,176-182,208,254,258-260,265,272-274,280,290-295 |
| GPIB Spectrum Analysis | 118-125 |
| GR, Accessories with GR Connectors | 346,347 |
| Graphic Computer Terminals | 68-76 |
| Graphics Software Library | 77,82 |
| Ground Adapter, Probe | 338,339 |
| Ground Leads, Probe | 338,339 |
| Hard Copy Units | 88-90 |
| High-Frequency Signal Generator | 270,271 |
| High-Current Transformer | 331 |
| High-Voltage Probes | 300,335 |
| Hoods, Viewing | 350 |
| Housing Accessory, BNC | 347 |
| Input Adapters, Cables | |
| BNC..... | 346 |
| BSM..... | 346 |
| GR..... | 346,347 |
| N..... | 346,347 |
| SMA (3 mm)..... | 346,347 |
| Instrument Carts, Mobile | 344,345 |
| Instrumentation System | 143-147,252-300 |
| Integrated Circuit Curve Tracer | 306-308 |
| Integrated Circuit Test Equipment | 36-40 |
| Interface Products | 290 |
| Isolated (Floating) Measurements | 340-343 |
| Latches, Digital | 64,267 |
| Leads, Patch Cord | 346 |
| Light Filters | 350 |
| Light Measurement | 311-314 |
| Logic Analysis Instruments | 43-66 |
| Logic Probe | 66,348 |
| Mainframes, TM 500 Test Instruments | 295-297 |
| Mechanical Measurement Transducers | 207 |
| Mesh Filters | 350 |
| Microcomputer Development Products | 12-25 |
| Microwave, Spectrum Analyzers | 118-130 |
| Mini-computer Based Systems | 146 |
| Mobile Instrument Carts | 344,345 |

*Contact your nearest Tektronix office or use the return card for more information.

Modular Probes 332,333

Multifunction Interface Extender 290

Monitors

Bistable Storage 99-101

Color Display 102-105

Display 94-105

High Brightness 97

High Resolution 104

Nonstorage 94-98

Raster Scan (Video) 96

Storage 99-101

Waveform, Television 106,107

Vector Display 108,109

X-Y 94-101

Mounting Adapters, Camera 319

Mounting Frames 349

Mounts, Cradle 349

Multimeters, Digital 198,232,254-257

Multiplexer 291

Noise Measurement Set, Television 284

N Connector Accessories 346,347

Operational Amplifier Plug-in Units 278

Oscillator, RC 283

Oscilloscopes

Battery Operated 222-249

Computer Controlled 143-146

CRT Readout 155-165,168-178,210,211

Curve Tracers 301-309

Data Analyzer 43-66,56,57

Delayed Sweep 155-178,206-215,222-236,242-245

Differential Input 155-178,206-215

Digital Delay 155-178,195,267

Digitizing 176-182,208,209,242,243

Digital Readout 155,165,168-175,205-211

Digital Servicing Aids 35,56,58,59

DMM 198,224,232,237,239

Dual-Beam 160,215

Dual-Trace 155-181,205-215,222-237,240-251,286-288

High-Frequency 155-178,205-207,210,211,222-235,242-245,286

High-Gain 155-178,205-215

Low-Frequency 214,215,236-240,246-249

Military Designator AN/USM425 234,235

Military Designator AN/USM 281C 166,167

Mixed Sweep (Calibrated) 193,230,244

Nonplug-in 222-249

Plug-in 155-178

Portable 222-249

Programmable 2-9,143-147,176-178

Rackmount 155-175,205-215,228-233,241-246

Readout CRT 155-165,168-178,210,211

Ruggedized 166,167,222-225,234,235

Sampling Plug-in 199-203,221

Storage

Bistable 168-174,214,215,246,249,251

Digital 177,178,208,209,242,243

Dual-Beam 215

Fast-Transfer 244,245

Multimode 168,169,172,173

Reference Information 138,139,168,169

Variable Persistence 168,169,174,175,211,244,245

TM 500 Oscilloscopes 286-289

TV Waveform 193,232,241,242,244

X-Y Plotting 155-178,205-215,228-237,242-247,288,289

Oscilloscope Calibration 279-283

Oscilloscope Cameras 316-323

Oscilloscope Carts 344,345

Patch Cords 346,347

Photometer/Radiometer 311-314

Plotters, Interactive Digital 86

Plug-in Carrying Cases 134

Plug-in Chassis 349

Plug-in Units

Ac RMS Digital Voltmeter 198,254-257

Bandpass Filter/Amplifier 278

Calibration Generators 279-283

CATV Preamp 133

CRT Readout 204

Curve Tracers 301-309

Delayed Sweep Sampler 201

Delaying Time Bases 190,191,193,195,213,220,221

Differential Amplifiers 186,187,218,219,278

Differential Comparator Amplifiers 186,218

Digital Counters 196,258-264

Digital Delay 55,195,267

Digital Multimeters 198,232,254-257

Digitizer Time Base 209,213

Dual Time Base (Mixed Sweep) 192,193

Dual-Trace Amplifiers 185,188,201,212,217,219,221

Dual-Trace Differential 219

Four-Trace Amplifier 216

Operational Amplifier 278

Oscillators 283,285

Oscilloscopes, Dual-Trace 155-181,205-215,222-237,240-251,286-288

Oscilloscopes, Single-Trace 155-181,205-215,238,239,289

Power Supplies, Programmable 265

Power Supplies (0-20 V variable) 266

Power Supplies for Plug-in Units 295,296

Programmable 185,189,254,258,259,260,261,265,274,280,281,290,294

Pulse Generators 268-271,203

Ramp Generators 272-276

Rate/Ramp Generators 275,276

Rf Sweep Generator 283

Sample/Hold Digital Voltmeter 198

Sampling 199-203,221

Sampling Heads 202,203

Single Time Bases 190,191,194,212,220

Single-Trace Amplifiers 184,186,188,199,200,216

Spectrum Analyzers 126-131

TDR 200

Tracking Generators 132

Universal Counter/Timers 196,260-264

Polarized Viewers 350

Portable Oscilloscopes 222-249

Portable Oscilloscopes, with

Digital Multimeter/Temperature 198,230-233,244,245

Portable Oscilloscope Power Supply 231,235,299

Portable Spectrum Analyzer 120-125

Power Divider, GR 347

Power Divider, SMA (3 mm) 347

Power Supplies (0-20 V variable) 266

Power Supplies for Plug-in Units 295,296

Preamplifier, Spectrum Analyzer 133

Probe Reference Charts 324-326

*Contact your nearest Tektronix office or use the return card for more information.

| | |
|---|---|
| Probes | |
| Accessories..... | 338,339 |
| Current..... | 277,329-331 |
| Data, Acquisition..... | 54 |
| Data, Passive..... | 326 |
| Differential..... | 328,336 |
| FET & 50 OHM..... | 327 |
| High Voltage..... | 300,335 |
| Logic..... | 65,348 |
| Modular..... | 332,333 |
| Pattern Generator..... | 55 |
| Reference Charts..... | 324-326 |
| RF..... | 300 |
| Temperature..... | 233,256,326 |
| Voltage..... | 324-328,332-337 |
| Word Recognizer..... | 57,65,326 |
| Programmable Instrumentation | 2-9,44-54,78-80,118-125,176-182,208,254,258-260,265,274,280,290-295 |
| Programmable Measurement System | 143-147 |
| Programmable Spectrum Analysis | 118-125 |
| Protective Covers | 344 |
| Pulse Generators | 201,268-271 |
| Rack Adapters | 349 |
| Ramp Generators | 272-276 |
| Raster Scan/Video Hard Copy Unit | 89 |
| Rate/Ramp Generator | 275-276 |
| RC Oscillator | 283,285 |
| Recognizer, Word | 55,267,348 |
| Refreshed Alphanumeric Terminal | 68-76 |
| RGB Color Monitors | 102-105 |
| Ruggedized Oscilloscopes | 166,167,222-225,234,235 |
| Sample/Hold Digital Voltmeter | 198 |
| Sampling Accessories | 202,203 |
| Sampling Plug-in-Units | 199-203,221 |
| Sampling Probes | 328 |
| SCOPE-MOBILE Carts | 344,345 |
| Semiconductor | |
| Automatic Test Equipment..... | 36-42,143-147,252-295 |
| Curve Tracers..... | 301-209 |
| Sideband Analyzer, Television..... | 133 |
| Signal Generators | |
| Constant Amplitude..... | 282 |
| Function..... | 272-276 |
| High Frequency..... | 270,271 |
| Pulse..... | 201,268-271 |
| Ramp..... | 272-276 |
| Rate/Ramp..... | 275,276 |
| RC Oscillator..... | 283,285 |
| RF Sweep..... | 283 |
| SECAM..... | 111 |
| Sinewave..... | 276 |
| Squarewave..... | 276 |
| Television Test Signal..... | 111-113 |
| Time-Mark..... | 282 |
| Tracking..... | 132 |
| Triangle..... | 275-276 |
| Signal Pickoff | 331 |
| Signal Processing Systems | |
| Mini-computer Based..... | 146 |
| Desktop Computer Based..... | 147 |
| Sinewave Signal Generators | 276 |
| SMA, Accessories with SMA (3 mm) | |
| Connectors | 347 |
| Software Products | 77,82,145 |
| Spectrum Analyzers | 118-134 |
| Spectrum Analyzers, Accessories | 125,134 |
| Squarewave Generators | 276 |
| Step Attenuators | 133 |
| Storage Cabinets, Plug-in | 349 |
| Storage Display Units | 99-101 |
| Storage Oscilloscopes | 138,139,168-175,208-215,242-249 |
| Swept Frequency System | 132 |
| Sync Generators, Television | 112,113 |
| Systems, Automatic Test | 36-42,143-147,252-295 |
| Television Products | |
| A to D Converters..... | 198 |
| Automatic Video Correctors..... | * |
| Automatic Video Measurement Set..... | 115 |
| Color Picture Monitors..... | 104 |
| D to A Converters..... | * |
| Demodulators..... | 110 |
| Noise Measurement Set..... | 284 |
| Sideband Analyzer..... | 133 |
| Sync Generators..... | 112,113 |
| Test Signal Generators..... | 111-113 |
| Vectorscopes..... | 108,109 |
| VITS Inserters..... | * |
| Waveform Monitors..... | 106-109 |
| Temperature Measurements | 233,256,326 |
| Terminals, Computer | 68-76 |
| Terminations | |
| BNC..... | 346 |
| GR..... | 346,347 |
| SMA (3 mm)..... | 347 |
| Test & Measurement Systems | 252-299 |
| Test Equipment, Automatic | 36-42,143-147,252-295 |
| Test Signal Generators, Television | * |
| Thermal Readout | 233 |
| Time-Domain Reflectometers (TDR) | 200 |
| Time-Mark Generators | 282 |
| Tips, Probe | 338,339 |
| Trace-Recording Cameras | 320-323 |
| Tracking Generators | 132 |
| Transducers | 207 |
| Transistor Curve Tracers | 301-209 |
| Transient Digitizer | 181 |
| Triangle Generators | 275-276 |
| TV Oscilloscopes | 193,232,241,242,244 |
| Universal Counter/Timer | 196,258-264 |
| Vectorscopes, Television | 108-109 |

*Contact your nearest Tektronix office or use the return card for more information.

| | |
|---|----------------------------|
| Video Hard Copy Unit | 88-90 |
| Video Waveform Monitors | 106, 107 |
| Viewing Accessories | 350 |
| Viewing Hoods | 350 |
| Voltage Probes | 324-328, 332-227 |
| Waveform Digitizing Instruments | 176-182, 208, 209, 242-243 |
| Waveguide Mixers | 125 |
| Waveform Monitors, Television | 106, 107 |
| Word Recognizer | 55, 267, 348 |
| Word Recognizer Probes | 65 |
| Writing Speed Enhancers, Camera | 320-323 |
| X-Y Monitors | 94-101 |
| Waveform Processing Oscilloscope | 193, 232, 241, 242, 244 |

| Type | Instrument Description | Page | Type | Instrument Description | Page |
|-----------------|--|------------|----------------|---|-----------------|
| AA 501 | Distortion Analyzer | 284 | FG 504,FG 504T | 40 MHz Function Generator.. | 272, 275 |
| ADC820 | Analog to Digital Converter | * | FG 507 | 2 MHz Sweeping Function Generator..... | 272, 275 |
| AF 501 | Bandpass Filter/Amplifier | 278 | FG 5010 | Programmable 20 MHz Function Generator | 272, 274 |
| AM 501 | Operational Amplifier | 278 | GMA 101A | Computer Display Module | 100 |
| AM 502 | Differential Amplifier | 278 | GMA102A | Computer Display Module | 100 |
| AM 503 | Current-Probe Amplifier..... | 277, 329 | GMA103 | Computer Display Module | 99 |
| AM-6565/U | Amplifier Plug-In | 166 | GMA125 | Large Screen Computer Display Module..... | 101 |
| AN/USM-281C | Ruggedized Oscilloscope..... | 166 | GV3257A | Automatic Change Over Unit..... | 113 |
| AN/USM425(V)1 | Portable Oscilloscope | 234 | J16 | Digital Photometer/Radiometer..... | 311 |
| A6302 | Current Probe | 277, 329 | L1 | 50-Ω Input for 7L5..... | 129 |
| A6303 | Current Probe | 277, 329 | L2 | 75-Ω Input for 7L5..... | 129 |
| A6701 | 18-Bit Word Recognizer..... | 348 | L3 | 1 MΩ, 75 Ω, 600 Ω Input for 7L5... | 129 |
| A6901 | Ground Isolation Monitor | 342 | L3-1 | 1 MΩ, 50 Ω, 600 Ω Input for 7L5 | 128 |
| A6902 | Isolator | 343 | M2 | Sample/Hold Module | 198 |
| C-5C | Oscilloscope Camera..... | 322 | MI 5010 | Programmable Multifunction Interface..... | 290 |
| C-28 | Oscilloscope Camera..... | 322 | MX 5010 | Interface Extender..... | 290 |
| C-30B | Oscilloscope Camera..... | 323 | OS-245(P)/U | Ruggedized Oscilloscope..... | 166 |
| C-31B | Oscilloscope Camera..... | 323 | PA1 | Cable Comparator for 1503 Cable Tester | 116 |
| C-51 | Oscilloscope Camera..... | 320 | PLOT 10 | Graphics Software Library..... | 77 |
| C-53 | Oscilloscope Camera..... | 320 | PLOT 50 | Graphics Software Library..... | 82 |
| C-59A | Oscilloscope Camera..... | 321 | PM101 | Microprocessor Personality Module | 60 |
| CG 551AP | Programmable Oscilloscope Calibration Generator..... | 280 | PM102 | Microprocessor Personality Module | 60 |
| CT-1 | Current Transformer | 331 | PM103 | Microprocessor Personality Module | 60 |
| CT-2 | Current Transformer | 331 | PM104 | Microprocessor Personality Module | 60 |
| CT-3 | Signal Pickoff | 331 | PM105 | Microprocessor Personality Module | 60 |
| CT-5 | Current Transformer | 331 | PM106 | Microprocessor Personality Module | 60 |
| DAC 850 | Digital to Analog Converter | * | PM107 | Microprocessor Personality Module | 60 |
| DAS 9101 | Digital Analysis System..... | 47 | PM108 | Microprocessor Personality Module | 60 |
| DAS 9102 | Digital Analysis System..... | 47 | PM109 | Microprocessor Personality Module | 60 |
| DAS 9103 | Digital Analysis System..... | 47 | PM110 | Microprocessor Personality Module | 60 |
| DAS 9104 | Digital Analysis System..... | 47 | PM111 | Microprocessor Personality Module | 60 |
| DAS 9109 | Mainframe..... | 47 | P6006 | 10X Probe..... | 334 |
| DAS 9119 | Mainframe (ATE Version)..... | 47 | P6007 | 100X Probe..... | 334 |
| DC 503A | 125 MHz Universal Counter..... | 262 | P6008 | 10X Probe..... | 334, 335 |
| DC 504 | 80 MHz Counter/Timer | 264 | P6009 | 100X Probe..... | 335 |
| DC 508A | 1.3 GHz Counter | 262 | P6010 | 10X Probe..... | 325 |
| DC 509 | 135 MHz Universal Counter/Timer | 258 | P6015 | 1000X Probe..... | 335 |
| DC 510 | 350 MHz Universal Counter/Timer | 260 | P6021,P6022 | Current Probes..... | 330 |
| DC 5009 | Programmable 135 MHz Universal Counter/Timer..... | 258 | P6028 | 1X Probe..... | 336 |
| DC 5010 | Programmable 350 MHz Universal Counter/Timer..... | 260 | P6046 | FET Differential Probe..... | 328 |
| DD 501 | Digital Delay | 267 | P6048 | 10X Probe..... | 328 |
| DF1 | Display Formatter..... | 64 | P6053B | 10X Probe..... | 336 |
| DF2 | Display Formatter..... | 64 | P6055 | 10X Probe..... | 336 |
| DL2 | Digital Latch | 64 | P6056 | 10X Probe..... | 328 |
| DL 502 | Digital Latch | 64, 267 | P6057 | 100X Probe..... | 328 |
| DM 501A | Digital Multimeter..... | 257 | P6060 | 10X Probe..... | 337 |
| DM 5010 | Programmable Digital Multimeter... | 254 | P6062B | 10X or 1X Probe..... | 337 |
| DM 502A | Autoranging Digital Multimeter..... | 255 | P6063B | 10X or 1X Probe..... | 337 |
| FG 501A | 2 MHz Function Generator | 272, 276 | P6101 | 1X Probe..... | 332 |
| FG 502 | 11 MHz Function Generator .. | 272, 276 | P6104 | Voltage Probe..... | 326 |
| FG 503 | 3 MHz Function Generator | 272, 276 | P6105 | 10X Probe..... | 332 |

Color identifies **NEW** products.

*Contact your nearest Tektronix office or use the return card for more information.

| Type | Instrument Description | Page | Type | Instrument Description | Page |
|----------------|---|--------------|----------------|------------------------------------|----------------|
| P6106 | 10X Probe..... | 333 | SPG12 | Television Sync Generator..... | 112 |
| P6107 | 10X Probe..... | 66, 333 | SPG2 | Television Sync Generator..... | 112 |
| P6108 | 10X Probe..... | 332 | T912 | 10 MHz Dual Trace Storage | |
| P6120 | Probe..... | 332 | | Oscilloscope..... | 249 |
| P6125 | 5X Counter Probe..... | 264, 300 | T922R | 15 MHz Rackmount Dual | |
| P6149 | 10X Probe..... | 333 | | Trace Oscilloscope..... | 241 |
| P6201 | FET Probe..... | 327 | TD-1085/U | Time Base Plug-In..... | 166 |
| P6202A | FET Probe..... | 327 | TDC | Television Down Converter..... | 110 |
| P6302 | Current Probe | | TDC-1 | Television Down Converter..... | 110 |
| | (See A6302)..... | 277, 329 | TDC-2 | Television Down Converter..... | 110 |
| P6303 | Current Probe | | TG 501 | Time Mark Generator..... | 279, 282 |
| | (See A6303)..... | 277, 329 | TM 501 | One-wide Mainframe..... | 296 |
| P6401 | Logic Probe..... | 66, 326, 348 | TM 503 | Three-wide Mainframe..... | 296 |
| P6406 | Word Recognizer Probe..... | 66 | TM 504 | Four-wide Mainframe..... | 296 |
| P6420 | 1X RF Probe..... | 300, 327 | TM 506,RTM 506 | Six-wide Mainframes..... | 296 |
| P6430 | Temperature Probe..... | 233, 326 | TM 515 | Five-wide Mainframe..... | 296 |
| P6451 | Data Acquisition Probes..... | 65, 326 | TM 5003 | Three-wide Mainframe..... | 295 |
| P6452 | Data Acquisition Probe..... | 66 | TM 5006 | Six-wide Mainframe..... | 295 |
| P6453 | High-Speed Data Acquisition Probe..... | 66 | TR 502, TR 503 | Tracking Generators..... | 132 |
| P6454 | 100 MHz Clock Probe..... | 66 | TSG1 | Television Test Signal Generator.. | 112 |
| P6455 | TTL/MOS Pattern Generator Probe..... | 66 | TSG11 | Television Test Signal Generator.. | 112 |
| P6456 | ECL Pattern Generator Probe..... | 66 | TSG12 | Television Test Signal Generator.. | 112 |
| P6601 | Temperature Probe..... | 256 | TSG13 | Television Test Signal Generator.. | 112 |
| PG 501 | 50 MHz Pulse Generator..... | 268, 271 | TSG15 | Television Test Signal Generator.. | 112 |
| PG 502 | 250 MHz Pulse Generator..... | 268, 271 | TSG16 | Television Test Signal Generator.. | 112 |
| PG 505 | 100 kHz Pulse Generator..... | 268, 271 | TSG2 | Television Test Signal Generator.. | 112 |
| PG 506 | Calibration Generator..... | 279, 282 | TSG3 | Television Test Signal Generator.. | 112 |
| PG 507 | Dual Output 50 MHz Pulse | | TSG5 | Television Test Signal Generator.. | 112 |
| | Generator..... | 268, 270 | TSG6 | Television Test Signal Generator.. | 112 |
| PG 508,PG508T | 50 MHz Pulse Generators..... | 268, 270 | TSP1 | Television Signal Processor..... | 112 |
| PS 501-1 | Power Supply..... | 266 | TSP11 | Television Signal Processor..... | 112 |
| PS 5010 | Programmable Triple | | WP Series | Waveform Processing | |
| | Power Supply..... | 265 | | Systems..... | 143 |
| PS 503A | Triple Power Supply..... | 266 | WR 501 | Word Recognizer..... | 267 |
| RG 501 | Ramp Generator..... | 276 | 5A13N | Differential Comparator | |
| S-1 | Sampling Head..... | 202 | | Amplifier..... | 218 |
| S-2 | Sampling Head..... | 202 | 5A14N | 1 MHz Four Trace Amplifier..... | 216 |
| S-3A | Sampling Head..... | 202 | 5A15N | 2 MHz Amplifier..... | 216 |
| S-4 | Sampling Head..... | 202 | 5A18N | 2 MHz Dual Trace Amplifier..... | 217 |
| S-5 | Sampling Head..... | 202 | 5A19N | Differential Amplifier..... | 218 |
| S-6 | Sampling Head..... | 203 | 5A21N | Differential Amplifier/Current | |
| S-51 | Trigger Countdown Head..... | 203 | | Probe Input..... | 218 |
| S-52 | Pulse Generator Head..... | 203 | 5A22N | Differential Amplifier..... | 219 |
| S-53 | Trigger Recognizer Head..... | 203 | 5A24N | Single Trace Amplifier..... | 216 |
| S-54 | Pulse Generator Head..... | 203 | 5A26 | Dual Differential Amplifier..... | 219 |
| S-3250 | Automated Test System..... | 38 | 5A38 | Dual Trace Amplifier..... | 212 |
| S-3270 | Automated Test System..... | 39 | 5A48 | Dual Trace Amplifier..... | 212 |
| S-3275 | Automated Semiconductor | | 5B10N | Time Base/Amplifier..... | 220 |
| | Test System..... | 37 | 5B12N | Dual Delayed Sweep Time Base... | 220 |
| S-3280 | Automated ECL Test System..... | 40 | 5B25N | Digitizer Time Base..... | 209,213 |
| SC 501 | 5 MHz Oscilloscope..... | 289 | 5B40 | Time Base..... | 212 |
| SC 502 | 15 MHz Dual Trace Oscilloscope.. | 288 | 5B42 | Delaying Time Base..... | 213 |
| SC 503 | 10 MHz Storage Oscilloscope..... | 287 | 5CT1N | Plug-in Curve Tracer..... | 221,309 |
| SC 504 | 80 MHz Oscilloscope..... | 286 | 5D10 | Waveform Digitizer..... | 214,217 |
| SG 502 | RC Oscillator..... | 283 | 5L4N | 20 Hz to 100 kHz Spectrum | |
| SG 503 | Leveled Sinewave Generator..... | 279, 283 | | Analyzer..... | 131,221 |
| SG 504 | Leveled Sinewave Generator..... | 279, 283 | 5S14N | Dual Trace Sampling Unit..... | 221 |
| SG 505 | Oscillator..... | 285 | 7A11 | Single Trace Amplifier..... | 187 |
| SI 5010 | Programmable Scanner..... | 291 | 7A13 | Differential Comparator | |
| SPG1 | Television Sync Generator..... | 112 | | Amplifier..... | 186 |
| SPG11 | Television Sync Generator..... | 112 | 7A15A | Single Trace Amplifier..... | 184 |

Color identifies **NEW** products.

*Contact your nearest Tektronix office or use the return card for more information.

| Type | Instrument Description | Page | Type | Instrument Description | Page |
|------------|--|----------|-------------|--------------------------------------|----------|
| 7A16A | Single Trace Amplifier | 184 | 178 | Linear IC Test Fixture..... | 308 |
| 7A16P | Programmable Amplifier.. 180,182,185 | | 200-C | SCOPE-MOBILE® Cart | 344 |
| 7A17 | Single Trace Amplifier | 186 | 205 | SCOPE-MOBILE® Cart | 344 |
| 7A18 | Dual Trace Amplifier..... | 185 | 206 | SCOPE-MOBILE® Cart | 345 |
| 7A19 | Single Trace Amplifier | 188 | 212 | 500 kHz Dual Trace Oscilloscope.. | 240 |
| 7A22 | Differential Amplifier | 187 | 213 | 1 MHz Oscilloscope/DMM | 239 |
| 7A24 | Dual Trace Amplifier..... | 188 | 214 | 500 kHz Dual Trace Storage | |
| 7A26 | Dual Trace Amplifier..... | 185 | | Oscilloscope | 248 |
| 7A29 | Dual Trace Amplifier..... | 188 | 221 | 5 MHz Portable Oscilloscope..... | 238 |
| 7B10 | Time Base..... | 190 | 284 | Pulse Generator | 201 |
| 7B15 | ΔDelaying Time Base..... | 190 | 305 | 5 MHz Dual Trace | |
| 7B50A | Time Base..... | 194 | | Oscilloscope/DMM | 237 |
| 7B53A | Dual Time Base..... | 193 | 308 | Data Analyzer | 56 |
| 7B80 | Time Base..... | 191 | 314 | 10 MHz Dual Trace Storage | |
| 7B85 | ΔDelaying Time Base..... | 191 | | Oscilloscope | 247 |
| 7B87 | Time Base w/Pretrigger | | | 35 MHz Dual Trace Oscilloscope.. | 236 |
| | Acquire Clock | 189 | 335 | 25 MHz Dual Trace Storage | |
| 7B90P | Programmable Time Base..... | 182, 189 | 434, R434 | Oscilloscopes..... | 246 |
| 7B92A | Dual Time Base..... | 192 | | 100 MHz Portable Storage | |
| 7CT1N | Plug-in Curve Tracer | 204, 309 | 464 | Oscilloscope | 244 |
| 7D01,7D01F | Logic Analyzer | 64 | 465B, R465B | 100 MHz Dual Trace Oscilloscopes | 232 |
| 7D02 | Logic Analyzer | 58 | 465M | 100 MHz Dual Trace | |
| 7D02F | Logic Analyzer | 64 | | Oscilloscope | 234 |
| 7D11 | Digital Delay | 195 | 466 | 100 MHz Portable Storage..... | 244 |
| 7D12 | A/D Converter | 198 | 468,R468 | 100 MHz Dual Trace Digital Storage | |
| 7D13A | Digital Multimeter..... | 198 | | Oscilloscope | 242 |
| 7D15 | Universal Counter/Timer | 196 | 475, R475 | 200 MHz Dual Trace Oscilloscope | 230 |
| 7K11 | CATV Preamplifier..... | 133 | 475A, R475A | 250 MHz Dual Trace Oscilloscope | 230 |
| 7L5 | Spectrum Analyzer | 128 | 485, R485 | 350 MHz Dual Trace Oscilloscopes | 228 |
| 7L12 | Spectrum Analyzer | 130 | 492 | Spectrum Analyzer | 122 |
| 7L14 | Spectrum Analyzer | 126 | 492P | Programmable GPIB Spectrum | |
| 7L18 | Spectrum Analyzer | 127 | | Analyzer | 122 |
| 7M11 | Dual 50 Ω Delay Line..... | 199 | 496 | Spectrum Analyzer | 120 |
| 7M13 | Readout Unit | 204 | 496P | Programmable GPIB Spectrum | |
| 7S11 | Sampling Unit | 199 | | Analyzer | 120 |
| 7S12 | TDR/Sampler | 200 | 520A | Television Vectorscope..... | 108 |
| 7S14 | Dual Trace Delayed | | 521A | Television Vectorscope..... | 108 |
| | Sweep Sampler | 201 | 522A | Television Vectorscope..... | 108 |
| 7T11 | Sampling Sweep Unit..... | 199 | 528A | Television Waveform Monitor..... | 107 |
| 3 | TEK Lab Cart..... | 297, 345 | 576 | Semiconductor Curve Tracer | 302 |
| 50M30 | Programmable Digital | | 577/D1 | Storage Curve Tracer Mainframe.. | 306 |
| | Input/Output Card..... | 290 | 577/D2 | Curve Tracer Mainframe | 306 |
| 50M40 | Programmable Relay | | 608 | High Brightness Display Monitor..... | 97 |
| | Scanner Card..... | 290 | 620 | General Purpose Waveform Monitor | 98 |
| 50M70 | Programmable Development Card | 291 | 624 | Direct Viewing Display Monitor | 97 |
| 69M00 | NTSC Decoder Interface Module .. | 104 | 634 | High Resolution Video Monitor | 96 |
| 69M41 | RGB Interface Module | 104 | 650HR | Television Picture Monitor | 105 |
| 91A04 | DATA Acquisition Module | 47 | 651HR | Television Picture Monitor | 105 |
| 91AE04 | DATA Acquisition Module | 47 | 653HR | Television Picture Monitor | 105 |
| 91A08 | DATA Acquisition Module | 47 | 655HR | Television Picture Monitor | 105 |
| 91A32 | DATA Acquisition Module | 47 | 656HR | Television Picture Monitor | 105 |
| 91P16 | Pattern Generator Module..... | 48 | 690SR | Television Picture Monitor | 104 |
| 91P32 | Pattern Generation Module | 48 | 832 | Data Comm Tester | 32 |
| 134 | Current Probe Amplifier..... | 330 | 833 | Data Comm Tester | 32 |
| 143 | Television Test Signal Generator .. | 111 | 834 | Programmable Data Comm Tester .. | 27 |
| 147A | Television Test Signal Generator | * | 834RDA | ROM Pack Development Aid..... | 29 |
| 148 | Television Test Signal Generator .. | 113 | 851 | Digital Tester..... | 35 |
| 148M | Television Test Signal Generator | * | 1101 | Probe Power Supply..... | 327 |
| 149A | Television Test Signal Generator | * | 1105 | Battery Power Supply..... | 235, 299 |
| 172 | Programmable Test Fixture..... | 304 | 1106 | Battery Pack | 231 |
| 176 | Pulsed High-Current Fixture | 305 | 1360P | Programmable Switch Controller... | 144 |
| 177 | Standard Test Fixture | 307 | 1360S | Switch Matrix..... | 144 |

Color identifies **NEW** products.

*Contact your nearest Tektronix office or use the return card for more information.

| Type | Instrument Description | Page | Type | Instrument Description | Page |
|----------------|--|---------|-------------|--------------------------------------|------|
| 1405 | Television Side-Band Adapter..... | 133 | 5110,R5110 | 2 MHz Single-Beam Oscilloscopes | 214 |
| 1410 | Television Generator Mainframe ... | 112 | 5111,R5111 | 2 MHz Single-Beam Storage | |
| 1411 | Television Generator Mainframe ... | 112 | | Oscilloscopes..... | 214 |
| 1420 | Television Vectorscope..... | 109 | 5113,R5113 | 2 MHz Dual-Beam Storage | |
| 1421 | Television Vectorscope..... | 109 | | Oscilloscopes..... | 215 |
| 1422 | Television Vectorscope..... | 109 | 5115,R5115 | 2 MHz Single-Beam Storage | |
| 1424 | X-Y Display Monitor | 109 | | Oscilloscopes..... | 215 |
| 1430 | Television Noise Measurement Set ... * | | 5223,R5223 | 10 MHz Digital Storage | |
| 1440 | Automatic Video Corrector | * | | Oscilloscope | 208 |
| 145M | Test Signal Generator | * | 5440,R5440 | 50 MHz Single-Beam Oscilloscope | 210 |
| 1450-1 | Television Demodulator Mainframe | 110 | 5441,R5441 | 50 MHz Variable Persistence | |
| 1450-2 | Television Demodulator Mainframe | 110 | | Storage Oscilloscope | 211 |
| 1450-3 | Television Demodulator Mainframe ... * | | 7104 | 1 GHz Real-Time Oscilloscope | 156 |
| 1470 | Television Test Signal Generator .. | 113 | 7603, R7603 | 100 MHz Oscilloscope | 164 |
| 1474 | Television Sync Generator | 113 | 7603N11S | Ruggedized Oscilloscope | |
| 1480 | Television Waveform Monitor | 106 | | System | 166 |
| 1481 | Television Waveform Monitor..... | 106 | 7612D | 200 MHz Programmable Waveform | |
| 1482 | Television Waveform Monitor..... | 106 | | Digitizer | 179 |
| 1485 | Television Waveform Monitor..... | 106 | 7613,R7613 | Variable Persistence Storage | |
| 1502, 1503 | TDR Cable Tester | 116 | | Oscilloscopes..... | 174 |
| 1900 | Television Test Signal Generator .. | 114 | 7623,R7623A | Multimode Storage | |
| 1980 | Automatic Video Measurement Set | 115 | | Oscilloscopes..... | 172 |
| 2213 | 60 MHz Dual Trace Oscilloscope .. | 226 | 7633,R7633 | Multimode Storage | |
| 2215 | 60 MHz Dual Trace Oscilloscope .. | 226 | | Oscilloscopes..... | 172 |
| 2335 | 100 MHz Dual Trace Oscilloscope | 223 | 7704A,R7704 | 250 MHz Oscilloscopes | 162 |
| 2336 | 100 MHz Dual Trace Oscilloscope | 223 | 7834 | Fast Storage Oscilloscope..... | 170 |
| 2337 | 100 MHz Dual Trace Oscilloscope | 223 | 7844,R7844 | 400 MHz Dual-Beam Oscilloscope | 160 |
| 2701 | 50 Ω Step Attenuator | 133 | 7854 | 400 MHz Waveform Processing | |
| 2703 | 75 Ω Step Attenuator | 133 | | Oscilloscope | 177 |
| 4006-1 | Computer Display Terminal..... | 76 | 7904,R7903 | 500 MHz Oscilloscopes | 158 |
| 4010-1 | Computer Display Terminal..... | 76 | 7912AD | Programmable Transient Waveform | |
| 4012 | Computer Display Terminal..... | 76 | | Digitizer | 181 |
| 4014-1 | Computer Display Terminal..... | 72 | 8540 | Microcomputer Integration Unit | 13 |
| 4015-1 | Computer Display Terminal..... | 72 | 8550 | Microcomputer Development Lab ... | 16 |
| 4016-1 | Computer Display Terminal..... | 73 | 8560 | Multi-User Microcomputer | |
| 4025A | Computer Display Terminal..... | 75 | | Development Lab | 14 |
| 4027A | Color Graphics Terminal | 74 | | | |
| 4041 | System Controller..... | 78, 292 | | | |
| 4051 | Desktop Computer..... | 80 | | | |
| 4052 | Desktop Computer..... | 80 | | | |
| 4054 | Desktop Computer..... | 79 | | | |
| 4112 | Computer Display Terminal..... | 70 | | | |
| 4114 | Computer Display Terminal..... | 71 | | | |
| 4611 | Hard Copy Unit | 88 | | | |
| 4612 | Video Hard Copy Unit | 89 | | | |
| 4631 | Hard Copy Unit | 90 | | | |
| 4632 | Video Hard Copy Unit | 90 | | | |
| 4633A | Continuous Recorder | 101 | | | |
| 4634 | Image Forming Module..... | 93 | | | |
| 4642 | Matrix Printer | 91 | | | |
| 4643 | Matrix Printer | 91 | | | |
| 4662 | Interactive Digital Plotter..... | 85, 86 | | | |
| 4663 | Interactive Digital Plotter..... | 87 | | | |
| 4907 | File Manager | 92 | | | |
| 4909 | Multi User File System..... | 84 | | | |
| 4923 | Digital Cartridge Tape Recorder | 92 | | | |
| 4924 | Digital Cartridge Tape Drive | 92 | | | |
| 4952 | Joystick..... | 92 | | | |
| 4953,4954,4956 | Graphic Tablets | 93 | | | |

Color identifies  products.

*Contact your nearest Tektronix office or use the return card for more information.

ASIA, AUSTRALIA, CENTRAL & SOUTH AMERICA, JAPAN

ARGENTINA
Coasin S.A.
 Virrey del Pino 4071
Buenos Aires
 Phone: 52-3185/5248/3485, 551-9364
 Telex: 390-012-2284
 Cable: COASIN, Buenos Aires
 25 de Mayo N° 1930
Cordoba
 Phone: 51-3037

AUSTRALIA
Tektronix Australia Pty. Limited
 80 Waterloo Road
 North Ryde, N.S.W. 2113
Sydney
 Phone: 888-7066
 Telex: AA24269
 Cable: TEKTRONIX Australia
 128 Gilles Street
Adelaide, South Australia 5000
 Phone: (08) 223-2811
 Canberra Office
 7 Dundas Court
 Townsend Street
 Phillip 2606
Canberra
 Australian (Capital) Territories
 Phone: (062)82-3587
 CNR, Russell and Council Sts.,
 Hawthorn East, Vic. 3123
Melbourne
 Phone: (03)813-1455
 66 Wellington Street
 East Perth, W.A. 6000
Perth
 Phone: (09)325-8433
 Cable: TEKTRONIX
 Brisbane Office
 737 Logan Road
 Greenslopes 4120
Queensland
 Phone: (07)394-1560

BANGLADESH
A. Q. Chowdhury & Co.
 33 Topkhana Road
 P.O. Box 118
Dacca-2
 Phone: 252329, 312492
 Telex: 642418 DCCI BJ
 Cable: ANALYST Dacca

BOLIVIA
Coasin Bolivia S.R.L.
 Avenida 6 de Agosto 2300
La Paz, Bolivia
 Phone: (2) 340962, 353365
 Telex: 5255
 Cable: COALAP
 Mailing Address: Casilla 7295

BRAZIL
Tektronix Industria e Comercio Ltda.
 Rua Franz Schubert 59
 CEP 01454 Sao Paulo
 Phone: 813-3011, 3223
 Telex: (011)21440 IS TEKK BR
 Rua Barao de Lucena, 32
 CEP 2000 Rio de Janeiro
 Phone: 286-6946
 Telex: (021)30120

CHILE
Equipos Industriales S.A.C.I.
 Moneda 812—Of. 912
 (Casilla 13550)
Santiago
 Phone: (2) 382-942
 Telex: 9249 FLOBRA/0241 FLOBRA
 Cable: FLOBRA, Santiago

CHINA, PEOPLES REPUBLIC OF
Tektronix Export Marketing
 P.O. Box 500
 Beaverton, Oregon 97077
USA
 Phone: (503) 644-0161
 Telex: 910 467-8708
 Cable: Tektronix

COLOMBIA
Selectronica Ltda.
 Apartado Aereo 25124
Bogota, D.E.
 Phone: 263 28 74

COSTA RICA
Electro-Impex, S.A.
 Apartado 620
San Jose, Costa Rica
 Phone: 21-59-34
 Telex: 2645 ELEPEX CR
 Cable: ELECTROIMPEX

ECUADOR
Proteco Coasin Cia Ltda.
 Ave. 12 de Octubre 2285
 (P.O. Box 228A)
Quito
 Phone: 52-6759, 52-9684
 Telex: 2865 PROTECO-ED
 Cable: PROTECO, Quito

EL SALVADOR
Electronica Cuscatleca
 21 Avenida Norte #1334
San Salvador
 Phone: 261654-253426
 Telex: 20329
 Cable: DITESAL

HONG KONG
Schmidt & Co., (H.K.) Ltd.
 28th Floor Wing on Centre
 111 Connaught Road Central
Hong Kong
 Phone: 5-455-644
 Telex: 74766 SCHMC HX
 Cable: SCHMIDTCO

INDIA
Hinditron Services Private Ltd.
 69-A, L. Jagmohandas Marg.
Bombay-400 006
 Phone: 81 12 58/81 53 44
 Telex: 011 2326
 Cable: TEKHIND
 33/44A Raj Mahal Vilas Exten
Bangalore-560 006
 Phone: 33139
 Telex: 36 72 89
 Cable: TEKHIND, Bangalore

INDONESIA
P.T. Dwi Tunggal Jaya Sakti
Jakarta
 Sangga Buana Bldg., 1st Floor
 J.L. Senen Raya 44, P.O. Box 4435
 Phone: 367390-9, 356801-5, 358801-5
 Telex: 46624 SABUANA IA
 46625 SABUANA IA
 Cable: DWITUJATI

JAPAN
Sony/Tektronix Corporation
 9-31, Kitashinagawa - 5,
 Shinagawa-Ku
Tokyo 141
 (P.O. Box 14, Hameda Airport,
 Tokyo 149)
 Phone: 448-4611 (Area 03/Tokyo)
 Telex: 02422850
 Cable: SONYTEK Tokyo
 c/o Taiso-Ebisu Bldg 1-6-11
 Ebisuminami Shibuya-ku
Tokyo 150
 Phone: 710-8141 (Area 03/Tokyo)
 c/o Takahashi Building North
 No. 2
 2-19 Isemachi Kita-ku
Osaka-shi 530
 Phone: 312-2751 (area 06/Osaka)
 Sanko Building
 21-7 Meieki 3-chome, Nakamura-ku
Nagoya 450
 Phone: (052)581-3547
 Osaka Ohbayashi Building
 3- Kyobashi, Higashi-ku
Osaka 540
 Phone: (06)947-0321
 Sumitomo Seimei Tsuchiura Bldg.
 16-12 Sakuracho-1
Tsuchiura 300
 Phone: (0298)24-2602
 Yamato Seimei Sendai Bldg.
 1-30 Ichibancho-1
Sendai 980
 Phone: (0222)67-2181
 Nihon Seimei Hakataekimae Bldg.
 2-1 Hakataekimae-3, Hakata-ku
Fukuoka 812
 Phone: (092)472-2626

KOREA
T&M Products Myoung Corp.
 220, Seongil Bldg.
 5-1 Moonbae-Dong
Seoul
 Phone: (2) 712-8433/2179
 Telex: K24283 MYOUNG
 Cable: MYOUNGCRP

MALAYSIA
MeComb Malaysia Sdn. Bhd.
 No. 2 Lorong 13/6A
 (P.O. Box 24)
Petaling Jaya, Selangor
 Phone: 773455
 Telex: 784-37605
 Cable: MECOMB Petaling Jaya

MEXICO
Tektronix S.A. de C.V.
 Kansas 67
 Colonia Napoles
Mexico 18, D.F.
 Phone: (905) 687-0904/0854/0827

NEW ZEALAND
McLean Information Technology Ltd.
 103-105 Feiton Mathew Avenue
 Glen Innes
 P.O. Box 18-065
Auckland 6
 Phone: 587-037
 Telex: NZ 2763 KOSFY
 Cable: KOSFY, New Zealand
 5th Floor, Westbrook House
 181 Willis Street
 (P.O. Box 496)
Wellington 1
 Phone: 851-450 844-425
 Telex: NZ 3053 KOSFY

PAKISTAN
Pak-Land Corporation
 Central Commercial Area
 Iqbal Road
 P.E.C.H. Society
Karachi-29
 Phone: 437315, 438084
 Cable: PAKLAND, Karachi

PANAMA
Executive Marketing Corp.
 Apartado 4929
Panama 5
 Phone: 64-9354, 64-9851
 Telex: 328-3483
 Cable: MARKETING PA, Panama

PERU
Importaciones y Representaciones Electronicas S.A. (IRE Ingenieros)
 Avda. Franklin D. Roosevelt 105
 Edificio Rimac
Lima
 Phone: 28-86-50
 Telex: 334-25663
 Cable: IREING, Lima

PHILIPPINES
Philippine Electronic Industries, Inc.
 3rd Floor, Rose Industries Bdg.
 11 Pioneer St.
Pasig, Metro Manila
 (P.O. Box 498, Makati Commercial Center)
Makati, Rizal 3116
 Phone: 693-1630
 Telex: (722) 43109 PEI PM
 Cable: PHILECTRON, Manila

SINGAPORE
MeComb
 10-12, Jalan Kilang
Singapore 0315
 Redhill Industrial Estate
 (P.O. Box 46,
 Alexandra Post Office)
Singapore 9115
 Phone: 2713333
 Telex: RS-23178
 Cable: MECOMB, Singapore

SRI LANKA
Stewart Roche Limited
 G.P.O. Box 61
Colombo
 Phone: 25846, 25847, 25848
 Telex: 1307 COLUMBO A/B ROCHES
 CE1307

SURINAM
Wong Sang Tsoi & Co.
 20-24 Dominestraat
 (P.O. Box 163)
Paramaribo
 Phone: 73511, 75187, 72154, 76369
 Cable: SANGTSOICO, Paramaribo

TAIWAN
Heighten Corporation
 16 Nanking East Road, Section 3
 P.O. Box 46-65
Taipei 104 ROC
 Phone: 551-9916
 Telex: 21472
 Cable: HEIGHTEN, Taipei

THAILAND
Dynamic Supply Engineering R.O.P.
 12 Soi Pasana 1, Ekamai
 Sukhumvit 63
Bangkok 11
 Phone: 392-8532, 5313
 391-9571
 Telex: 82455 DYNASUP-TH
 Cable: Dynasupply

URUGUAY
Coasin Uruguay S.R.L.
 Casilla de Correo No. 1400
Montevideo
 Phone: 20 39 13, 29 31 95
 Cable: COAUR, Montevideo

VENEZUELA
Equilab, C.A.
 Torre KLM 6° Piso
 Avenida Romulo Gallegos
 Santa Eduvigis
 (Apartado 60497)
Caracas 107
 Phone: 283, 1166 (5 lines)
 Telex: 21860 EQUIL
 Cable: EQUILAB, Caracas

AREAS NOT LISTED, CONTACT:
Tektronix, Inc.
 Export Marketing
 P.O. Box 1700
Beaverton, Oregon 97075
 U.S.A.
 Phone: (503)644-0161
 Telex: 910-467-8708
 Cable: TEKTRONIX

AFRICA, EUROPE, MIDDLE EAST
AFRICA
Rohde & Schwarz Eng. & Sales Co. Ltd.
 P.O. Box 46658
Kenya, Nairobi
 Phone: (2) 26815, 26386
 Telex: 22030 ENGSAL
 Cable: ENGSAL

ALGERIA
Sales: Tektronix Limited
 P.O. Box 36
 Guernsey, Channel Islands
 144 Bd Salah Bouakour
Algiers
 Phone: 61.50.99 and 61.50.24
 Telex: 53733 TEKNY DZ

ANGOLA
Tecnidata Representacoes Tecnicas e Electronica Aplicada Lda
 Rua Sociedade de Geografia
 21-21A
 Caixa Postal 1619
Luanda
 Phone: 32025-32309
 Telex: 3019 TECDATA AN

AUSTRIA
Rohde & Schwarz-Tektronix Ges.m.b.H.
 Sonnelithnergasse 20
 A-1100 Vienna
 Phone: Vienna (222) 62 61 41
 Telex: Vienna 13933

BELGIUM
Tektronix nv/sa
 Mercure Centre
 Rue de la Fusee 100
 1130 Bruxelles
 Phone: 02/720.80.20
 Telex: 26713
 Cable: TEKBEL

BULGARIA
Rohde & Schwarz-Tektronix Ges.m.b.H.
 Sonnelithnergasse 20, A-1100
Vienna, Austria
 Phone: Vienna 62 61 41
 Telex: Vienna 13933

CZECHOSLOVAKIA
Rohde & Schwarz-Tektronix Ges.m.b.H.
 Sonnelithnergasse 20, A-1100
Vienna, Austria
 Phone: Vienna 62 61 41
 Telex: Vienna 13933

DENMARK
Tektronix A/S
 Herlev Hovedgade
 Post Box 575
 DK-2730 Herlev
 Phone: (02) 84 56 22
 Telex: 35239 Tekas dk

EAST AFRICA (Kenya, Tanzania and Uganda)
Engineering & Sales Co., Ltd.
 Bankhouse, Moi Avenue
 (P.O. Box 46658)
Nairobi, Kenya
 Correo Central
 Phone: 26815, 26386
 Telex: 22030 ENGSAL
 Cable: ENGSAL Nairobi

EGYPT
Giza Systems Engineering Company
 P.O. Box 1913
 2 Medan El Mesaha
Dokki Cairo
 Phone: 841200, 849399, 849200
 Telex: 92096 EKA UN
 93644 ALKAN UN

FEDERAL REPUBLIC OF GERMANY
Tektronix GmbH
 Ernst-Reuter-Platz 3 5/11
 D-1000 Berlin-West 10
 Phone: (030) 3139081
 Telex: 185804
 Cable: ROHDESCHWARZ Berlin
Tektronix GmbH
 Schoenhauser Strasse 62 64
 D-5000 Cologne 51
 Phone: (221)375081
 Telex: 8885541
 Grosse Bergstrasse 213-217
 D-2000 Hamburg 50
 Phone: (040) 38 01 91
 Telex: 213 749
 Cable: ROHDESCHWARZ Hamburg
 Herzogstrasse 61
 6078 Neu-Isenburg
 Phone: (06102) 3136
 Telex: 04185641
 Kriegsstrasse 39
 D-7500 Karlsruhe 1
 Phone: (0721) 2 79 81
 Telex: 7 825 301
 Cable: ROHDESCHWARZ Karlsruhe
 Sedanstrasse 13-17
 D-5000 Koln 1
 Phone: (0221) 77 22-1
 Telex: 888-5417
 Cable: ROHDESCHWARZ Koln
 Ehrenbreitsteinerstrasse 36
 8000 Munchen 50
 Phone: (089) 14 85-1
 Telex: 522953
 Cable: ROHDESCHWARZVERTRIEB
 Donaustrasse 36
 D-8500 Nurnberg 60
 Phone: (0911) 646081
 Telex: 0626255
 Osaka Ohbayashi Building
 3-37 Kyobashi, Higashi-ku
Osaka 540
 Phone: (06)947-0321
 Technisches Buro
 Pliening Strasse 150
 7000 Stuttgart 80
 Phone: (0711) 72 20 39
 Telex: 0725533

FINLAND
Tektronix O/Y
 Larin Kyostin tie 4,
 SF-00650 Helsinki 65
 Phone: 0-722 400
 Telex: 12-3435 TEKOFY SF

FRANCE

Tektronix
Z.I. de Courtaubeuf, B.P. 13
91941 Les Ulis Cedex
Phone: 907 78 27
Telex: TEKOR 690332
Cable: TEKOR

Centre Regional de Lyon
163, Boulevard des Etats-Unis
69008-Lyon
Phone: (78) 76.40.03
Telex: TEKLYON 300150

Centre Regional d'Aix en Provence
Z. I. d'Aix
13763 LES MULES CEDEX
Phone: (42) 26.62.03
Telex: TAKAIX 440045

Centre Regional du SUD-EST
Z.I. Rue Andre Ampere
13290 Aix-Les-Milles
Phone: (42) 26.62.03
Telex: 440045

Centre Regional de Rennes
103A, Avenue de Crimée
35000 Rennes
Phone: (99) 51 21 16
Telex: TEKREN 740829

Centre Regional de Strasbourg
Rue du Marechal Lefebvre
67100 Strasbourg
Phone: (88) 39.49.35
Telex: TEKSTBG 890470

Centre Regional de Toulouse
284, Route Saint-Simon
31300 Toulouse
Phone: (61) 40 24 50
Telex: TEKTOUL 530243

La Defense
39 Boulevard des Bouvets
92000 Nanterre
Phone: (1) 776 13 53
Telex: TEKNANT 613737

GREECE

Marios Dalleggio Representations
2, Alopekis Street
Athens 139
Phone: 749511/2,3,4
Telex: 216435
Telex Answer Code: DALM GR
Cable: DALMAR Athens

HUNGARY

**Rohde & Schwarz-
Tektronix Ges.m.b.H.**
Sonnleithnergasse 20, A-1100
Vienna, Austria
Phone: Vienna 62 61 41
Telex: Vienna 13933

ICELAND

Kristjan O. Skagfjord Ltd.
P.O. Box 906
Reykjavik
Phone: 24120
Telex: 2133 KOS IS

ISRAEL

Eastronics Ltd.
11 Rozanis Street
Tel-Baruch
(P.O. Box 39300) 61392
Tel Aviv
Phone: 475151
Telex: 342610 DATIX IL
33638 RONIX IL
Cable: EASTRONIX Tel Aviv

ITALY

Tektronix S.p.A.
Via Lampeusa 13
20141 Milan
Phone: 02/8466946 02/8466446
Telex: 315217 TEKML I

Piazza Antonio Baldini 38/43
00141 Roma
Phone: 06/8278041/4
Telex: 616018 TEKROM I

Via Cardinal M. Fossati 5
10141 Turin
Phone: 011/330143 011/372163
Telex: 212543 TEKTOR I

IVORY COAST

Sitel
Blvd. Giscard D'Estaing-
Carrefour
de Marcoray Zone 4A
Abidjan 01 BP 2580
Phone: 353600 or 353502
Telex: 3354 SITEL CI
Cable: RAYBACH ABIDJAN

JORDAN

Consult-Tel
P.O. Box 35055
Amman
Phone: 42333
Telex: 22345
Cable: CONSULTEL

KUWAIT

Tareq Company Ltd.
P.O. Box Safat 20506
Phone: 436100 & 436045
Telex: 22315 ZUAITER KT
Cable: ZUAITER KUWAIT

LEBANON

Projects S.A.L.
(P.O. Box 11-5281)
Beirut
Phone: 331680
Telex: 20466 LE
Cable: PROJECTS Beirut

MOROCCO

SCRM
75 Avenue Fal Ould Oumeir
Rabat Agdal
Phone: (07) 749-47
Telex: SCRM 32739 M

THE NETHERLANDS

Tektronix Holland N.V.
Meidoornweg 2
P.O. Box 164
Meidoornweg 2
1170 AD Badhoevedorp
Phone: 02968-1456
Telex: 18490

NORWAY

Tektronix Norge A/S
Lorenfaref 1,
Okern
Oslo 5
Phone: 02-21 28 55
Telex: 56-17690 TEK N

POLAND

**Rohde & Schwarz-
Tektronix Ges.m.b.H.**
Sonnleithnergasse 20, A-1100
Vienna, Austria
Phone: Vienna 62 61 41
Telex: Vienna 13933

PORTUGAL

**Decada Equipamentos
de Electronica Lda.**
Rua Pedro Nunes 47c-1000 Lisboa
P.O. Box 1128 (1003 Lisboa Codex)
Lisbon
Phone: (19) 574159
Telex: 18469 NONJO P
Cable: TLX 18469 NONJO P

QATAR(Arabian Gulf)

**Business Communications
Qatar**
P.O. Box 3656
Doha
Phone: 325851
Telex: 4454 BCO DH
Cable: BCO/DH

REPUBLIC OF SOUTH AFRICA

**Protea Physical & Nuclear
Instrumentation (Pty.)
Ltd.**
P.O. Box 39127
Bramley 2018
746 6th Street
Wynberg, Standton
Transvaal
Phone: (27 11) 786-3647
Telex: 4-24409 SA

P.O. Box 12
Goodwood 7460
Cape
(Capetown Branch)
Phone: (21) 98-3439
Telex: 5-77551 SA

P.O. Box 47031
Greyville 4023
273 Florida Rd
Durban
Phone: (031) 39-1100
Telex: 60981 SA

Protea Medical Services

Pvt Ltd.
P.O. Box 2766
Salisbury
111 Kelvin Road South
Graniteside, Salisbury
Zimbabwe
Phone: 704094
Telex: 4102 RH
Cable: MANLY

ROMANIA

**Rohde & Schwarz-
Tektronix Ges.m.b.H.**
Sonnleithnergasse 20, A-1100
Vienna, Austria
Phone: Vienna 62 61 41
Telex: Vienna 13933

SAUDI ARABIA

**Electronic Equipment
Mktg. Co. Ltd.**
P.O. Box 3750
Riyadh
Phone: 32761, 37023, 32700
Telex: 201120 Zuhair SJ
Cable: MARTEL

SPAIN

Tektronix Espanola S.A.
c/Condesa de Venadito 1-5 IZQ
Madrid 27
Phone: (1) 404-1011
Telex: 46014 TKMK E
Gran Via Carlos 111 97G
Barcelona 28
Phone: (93) 330-2008
Telex: 97398 TKBE E

SUDAN

**Cine & Photo Supply
Company (CPSC)**
P.O. Box 393
Khartoum
Phone: 81151,81156,81277,75887
Telex: 304 Photokina
Cable: PHOTOKINA

SWEDEN

Tektronix AB
Box 4205
Anderstorp svagen 12
S-171 04 Solna
Phone: 08/83 00 80
Telex: 17831 Tekswed S Stockholm
Cable: TEKTRSWED

SWITZERLAND

**Tektronix
International A.G.**
(P.O. Box 57)
CH-6301 Zug
Phone: 042 21 91 92
Telex: 78808
Cable: TEKINTAG

SYRIA

General Trading Co.
P.O. Box 798
Damascus
Phone: 114807, 224170, 559108
Telex: 11283 GITCO SY

TURKEY

Erkman Elektronik Aletler
Ticaret Anonim Sirketi
Necatibey Caddesi 92/3
Karakoy, Istanbul
Phone: 44 15 46/44 76 51
Telex: 23353 MSE TR
Cable: INGMESUER, Istanbul

TUNISIA

Societe El Eslek
3 Rue de la Monnaie
1001 Tunis Republique
Tunis
Phone: 244372
Telex: 13664 ESLEK TN

UNITED KINGDOM

Tektronix U.K. Limited
Beaverton House
36-38, Coldharbour Lane
(P.O. Box 69)
Harpenden Herts AL5 4UP
Phone: Harpenden 63141
Telex: 25559
Cable: TEKTRONIX Harpenden
134, Bridge Rd.
Maidenhead, Berkshire SL6 8DJ
Phone: 0628-73211
Telex: 847378

(Manchester)

Sovereign House
232/234 Stockport Road
Cheadle, Stockport SK8 2EA
Phone: 061-428-0799

Portland House,
Almondvale So. Livingston,
West Lothian, EH54 6NG
Phone: Livingston 32766/7

Dublin

Deans Grange Estate
Kill Lane
Black Rock, Co. Dublin
Phone: 850685/850796

USSR

**Rohde & Schwarz
Tektronix Ges.m.b.H.**
Sonnleithnergasse 20, A-1100
Vienna, Austria
Phone: Vienna 62 61 41
Telex: Vienna 13933

YUGOSLAVIA

**Rohde & Schwarz
Tektronix Ges.m.b.H.**
Sonnleithnergasse 20, A-1100
Vienna, Austria
Phone: Vienna 62 61 41
Telex: Vienna 13933

ZAMBIA

**Baird and Tatlock
(Zambia) Ltd.**
Chandwe Musonda Road
(P.O. Box 1038)
Lusaka
Phone: 75315/6
Telex: 4277
Cable: PIPETTE, Lusaka

Brunell Road (P.O. Box 1097)

Ndola
Phone: 3522 & 2253/4/6
Telex: 3441
Cable: PIPETTE, Ndola

EASTERN EUROPEAN Countries Not Listed, Contact:

**Rohde & Schwarz-
Tektronix Ges.m.b.H.**
Sonnleithnergasse 20, A-1100
Vienna, Austria
Phone: Vienna 62 61 41
Telex: Vienna 13933

Other Areas Not Listed, Contact:

Tektronix Limited
P.O. Box 36
Guernsey, Channel Islands
Phone: Guernsey (0481) 35781
Telex: 4191193
Cable: TEKTRONIX GUERNSEY

CANADA

**CANADA
Tektronix Canada Inc.**
P.O. Box 6500, 50 Alliance Blvd.
Barrie, Ontario
L4M4V3
Phone: (705)737-2700
Telex: 06-875672
Cable: TEKANADA

Toronto

Unit 20-21
89 Galaxy Boulevard
Ontario S. B. Rexdale
N9W6A4
Phone: (705)675-3865
Telex: 06-989324

(Montreal)

900 Selkirk Street
Pointe Claire, Quebec
H9R 3S3
Phone: (514)697-5340
Telex: 05-821570
Cable: TEKANADA

Suite 106
3016, 19th St. N.E.
Calgary, Alberta
T2E 4Y3
Phone: (403) 230-1836
Telex: 038-21730

6025 103 A Street
Edmonton, Alberta
T6H 2J7
Phone: (403)434-9466
Telex: 037-2795

1642 Woodward Drive
Ottawa, Ontario
K2C 3R8
Phone: (613)225-2850
Telex: 053-4119

(Vancouver)

4519 Canada Way
Burnaby, B.C.
V5B 1K1
Phone: (604) 438-4321
Telex: 043-54602

Unit 68, Border Place
1313 Border St.

Winnipeg, Manitoba
R3H 0X 4
Phone: (204)632-4447, 632-4448
Telex: 07-55584

(Halifax)

Burnside Commercial Centre
10 Akerly Blvd.
Dartmouth, Nova Scotia
B3B 1J4
Phone: (902)469-9476
Telex: 019-31534

CANADIAN AREAS Not Listed, Contact:

Tektronix Canada Inc.
P.O. Box 6500
Barrie, Ontario
L4M 4V3
Phone: (705) 737-2700
Telex: 06-875672
Cable: TEKANADA

TEKTRONIX WORLDWIDE MARKETING CENTERS

U.S.A.

Tektronix, Inc.

U.S. Marketing

P.O. Box 1700
Beaverton, Oregon 97075
Phone: (503)644-0161
For additional literature,
or the address and phone
number of the Tektronix
Sales Office nearest you,
contact
P.O. Box 4828
Portland, OR 97208
Phone: 800/547-1512
Oregon only 800/452-1877

AFRICA, EUROPE, MIDDLE EAST

Tektronix Europe B.V.

European Headquarters

Postbox 827
1180 AV Amstelveen
Bavinkstaete
Prof. Bavinklaan 5
1183 Amstelveen
The Netherlands
Phone: (20) 471146
Telex: 18312

AMERICAS/PACIFIC (Asia, Australia, Central & South America, Japan)

Tektronix, Inc.

Export Marketing

P.O. Box 500
DS 51-297
Beaverton, Oregon 97077
Phone: (503)643-8942
For additional literature,
or the address and phone
number of the Tektronix
Sales Office nearest you,
contact
Phone: (800)547-1512
Oregon only: (800)452-6773
Telex: 910-467-8708
Cable: TEKTRONIX

Tektronix, Inc.

Telephone: (503)644-0161

For additional literature, or the address

and phone number of the Tektronix Sales

Office nearest you, contact:

(800)547-1512 Telephone: Oregon only (800)452-1877

Telex: 910-467-8708 TEKTRONIX BEAV. Cable: TEKTRONIX

Mailing Address: Tektronix, Inc., Beaverton, Oregon 97077

Corporate Office: Tektronix, Inc., 4900 S.W. Griffith Drive, Beaverton, Oregon

Principal Plant: Tektronix Industrial Park, Beaverton, Oregon

For 2200 Series and accessory products, you can order direct by calling 800-547-1845. In Alaska, Hawaii and Oregon call collect (503) 627-5402.

ALABAMA**Huntsville 35801**3322 S. Memorial Parkway
Suite 203
Phone: (205)881-2912**ARIZONA****Phoenix 85040**4130 East Wood Street
Suite 100
Phone: (602)268-8861
Tucson Area 790-3099**Mailing Address:**

P.O. Box 29540

Phoenix, Arizona 85038**CALIFORNIA
(Concord)**3451 Vincent Road
Pleasant Hill 94523
Phone: (415)932-4949
(415)932-4722
From Okland: (415)254-5353**Irvine 92714**17052 Jamboree Blvd.
or P.O. Box 19523
Irvine 92713
Phone: (714)556-8080
(213)778-5225**(Los Angeles)**21300 Erwin Street
Service Center
20920 Victory Blvd.
Woodland Hills 91367
Phone: (213)999-1711
Mailing Address:
P.O. Box 8500
Woodland Hills, 91365**San Diego 92111**7827 Convoy Court
Suite 401
Phone: (714)292-7330**Santa Clara 95050**3003 Bunker Hill Lane
Phone: (408)496-0800**COLORADO
(Denver)**14 Inverness Dr. East
Suite 4A
Englewood 80112
Phone: (303)773-1011
Telex: (Infocom)45-4455**CONNECTICUT****Milford 06460**40 Commerce Park Road
Phone: (203)877-1494**FLORIDA****Fort Lauderdale 33309**2745 N.W. 62nd St. Suite B
Phone: (305)973-9300
Also serves Puerto Rico and
U.S. Virgin Islands
From Miami 947-6053**Orlando 32803**3657 Maguire Blvd., Suite 100
Phone: (305)894-3911
From the Cape Kennedy Area:
636-0343**Pensacola 32505**6425 N. Pensacola Blvd.
Phone: (904)476-1897**GEORGIA****(Atlanta)**P.O. Box 1246
3320 Holcomb Bridge Road
at Peachtree Industrial Blvd.**Norcross 30091**

Phone: (404)449-4770

Mailing Address:

P.O. Box 1246

Norcross, GA 30091**HAWAII****Honolulu 96819**EMC Corporation
2979 Ualena Street
Phone: (808)836-1138**ILLINOIS****(Chicago)**5350 Keystone Ct.
Rolling Meadows 60008
Phone: (312)259-7580**INDIANA****Indianapolis 46219**6121 East 30th Street
Phone: (317)545-2351**KANSAS****(Kansas City)**10580 Barkley
Suite 62
Overland Park 66212
Phone: (913)341-3344**LOUISIANA****(New Orleans)**1940 I-10 Service Rd.
Concourse Place
Kenner 70062
Phone: (504)466-4445**MARYLAND****(Baltimore)**1526 York Road
Lutherville 21093
Phone: (301)321-7000**Rockville 20850**2 Research Court
Phone: (301)948-7151

(Rockville Annex)

19 Firstfield Road
Gaithersburg 20760
Phone: (301)948-7151**MASSACHUSETTS****(Boston)**482 Bedford Street
Lexington 02173
Phone: (617)861-6800**MICHIGAN****(Detroit)**24155 Drake Road
Farmington 48024
Phone: (313)478-5200**MINNESOTA****St. Paul 55112**4660 Churchill Rd.
Phone: (612)484-8571**MISSOURI****(St. Louis)**422 Anglum Rd.
Hazelwood 63042
Phone: (314)731-4696**NEW JERSEY****Woodbridge 07095**40 Gill Lane
Phone: (201)636-8616**NEW MEXICO****Albuquerque 87108**1258 Ortiz Drive, S.E.
Phone: (505)265-5541
Southern N.M. Area: ENterprise 678
Southern Nevada Area: ENterprise 678**NEW YORK****Albany 12205**16 Computer Drive West
Phone: (518)458-7291**(Long Island)**100 Crossways Park West
Woodbury, L.I. 11797
Phone: (516)364-9060
(212)895-9215**Poughkeepsie 12603**38 Haight Avenue
Phone: (914)454-7540**Rochester 14623**1210 Jefferson Rd.
Phone: (716)424-5800**(Syracuse)**1 Northern Concourse
North Syracuse 13212
Phone: (315)455-6661
From New York: (800)962-1095**NORTH CAROLINA****Raleigh 27612**3725 National Dr.
Suite 104
Phone: (919)782-5624**OHIO****(Cleveland)**7830 Freeway Circle
Middleburg Heights 44130
Phone: (216)243-8500
Dayton 45449
501 Progress Rd.
Phone: (513)859-3681**OKLAHOMA****Oklahoma City 73105**800 N.E. 63rd
Suite 201
Phone: (405)848-3361**OREGON****(Portland)**10220 S.W. Nimbus Dr.
Suite K-4
Tigard 97223
Phone: (503)620-9100**Factory Service Center**Tektronix Industrial Park
Beaverton 97077
Phone: (503)642-8600
Telex: 910-467-8708**PENNSYLVANIA****(Philadelphia)**1720 Walton Road
Blue Bell 19422
Phone: (215)825-6400
From Harrisburg, Lancaster, and
York Area: ENterprise 1-0631**Pittsburgh 15221**1051 Brinton Rd.
Suite 300
Phone: (412)244-9800**TENNESSEE****Knoxville 37923**9041 Executive Park Dr.
Suite 616
Phone: (615)690-6422**TEXAS****Irving, 75062**1551 Corporate Drive
P.O. Box 5027
Phone: (214)258-0525**Houston 77099**10887 S. Wilcrest Drive
Phone: (713)933-3000**San Antonio 78226**3311 Roselawn
Phone: (512)434-4334**UTAH****Salt Lake City 84115**Timesquare Park 300 Mercer Way
Phone: (801)486-1091**VIRGINIA****Newport News 23602**606 Denbigh Blvd.
Suite 703
Phone: (804)874-0099**WASHINGTON****(Seattle)**19026 72nd Ave.S.
Kent 98031
Phone: (206)575-0180



NO POSTAGE
NECESSARY
IF MAILED
IN THE
UNITED STATES

BUSINESS REPLY MAIL

FIRST CLASS PERMIT NO. 1 BEAVERTON, OR

POSTAGE WILL BE PAID BY ADDRESSEE

Tektronix, Inc.
Attn: Fulfillment
P.O. Box 1700
Beaverton, Oregon 97075

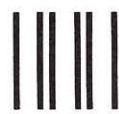
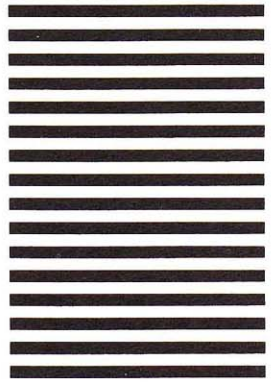

NO POSTAGE
NECESSARY
IF MAILED
IN THE
UNITED STATES

BUSINESS REPLY MAIL

FIRST CLASS PERMIT NO. 1 BEAVERTON, OR

POSTAGE WILL BE PAID BY ADDRESSEE

Tektronix, Inc.
Attn: Fulfillment
P.O. Box 1700
Beaverton, Oregon 97075

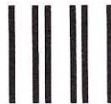

NO POSTAGE
NECESSARY
IF MAILED
IN THE
UNITED STATES

BUSINESS REPLY MAIL

FIRST CLASS PERMIT NO. 1 BEAVERTON, OR

POSTAGE WILL BE PAID BY ADDRESSEE

Tektronix, Inc.
Attn: Fulfillment
P.O. Box 1700
Beaverton, Oregon 97075



Please have a Sales Representative contact me regarding

My phone number is _____ **Ext** _____

Send me information on:

- 5D10 Waveform Digitizers for 5000 Series mainframes
- Computer Graphic Products
- GPIB Products
- Signal Processing Systems
- _____ (Product) Applications
- Customer Training
- Tektronix Service Programs for _____ Products
- Please drop me from your mail list.

Name _____ Title _____

Firm _____

Address _____

City _____ State _____ Zip _____ D551
(Please type or print)

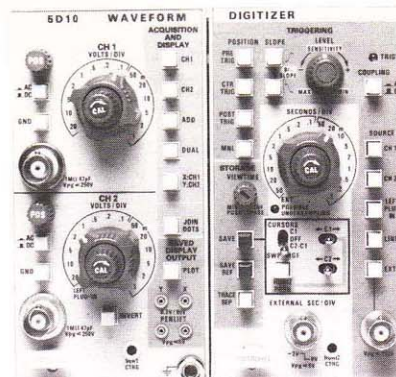

5D10 Waveform Digitizer



Please have a Sales Representative contact me regarding

My phone number is _____ **Ext** _____

Send me information on:

- 5D10 Waveform Digitizers for 5000 Series mainframes
- Computer Graphic Products
- GPIB Products
- Signal Processing Systems
- _____ (Product) Applications
- Customer Training
- Tektronix Service Programs for _____ Products
- Please drop me from your mail list.

Name _____ Title _____

Firm _____

Address _____

City _____ State _____ Zip _____ D551
(Please type or print)

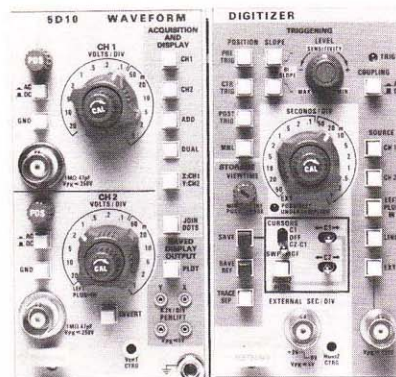

5D10 Waveform Digitizer



Please have a Sales Representative contact me regarding

My phone number is _____ **Ext** _____

Send me information on:

- 5D10 Waveform Digitizers for 5000 Series mainframes
- Computer Graphic Products
- GPIB Products
- Signal Processing Systems
- _____ (Product) Applications
- Customer Training
- Tektronix Service Programs for _____ Products
- Please drop me from your mail list.

Name _____ Title _____

Firm _____

Address _____

City _____ State _____ Zip _____ D551
(Please type or print)

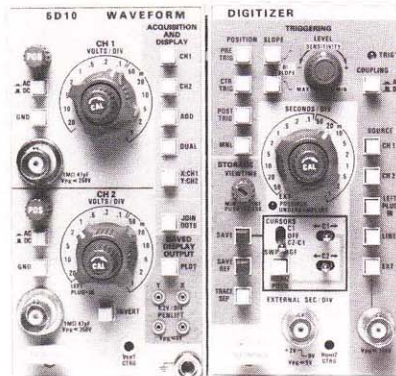

5D10 Waveform Digitizer



TEK SERVICE

PACKAGED WITH EVERY TEKTRONIX PRODUCT:

A WORLDWIDE SERVICE NETWORK.

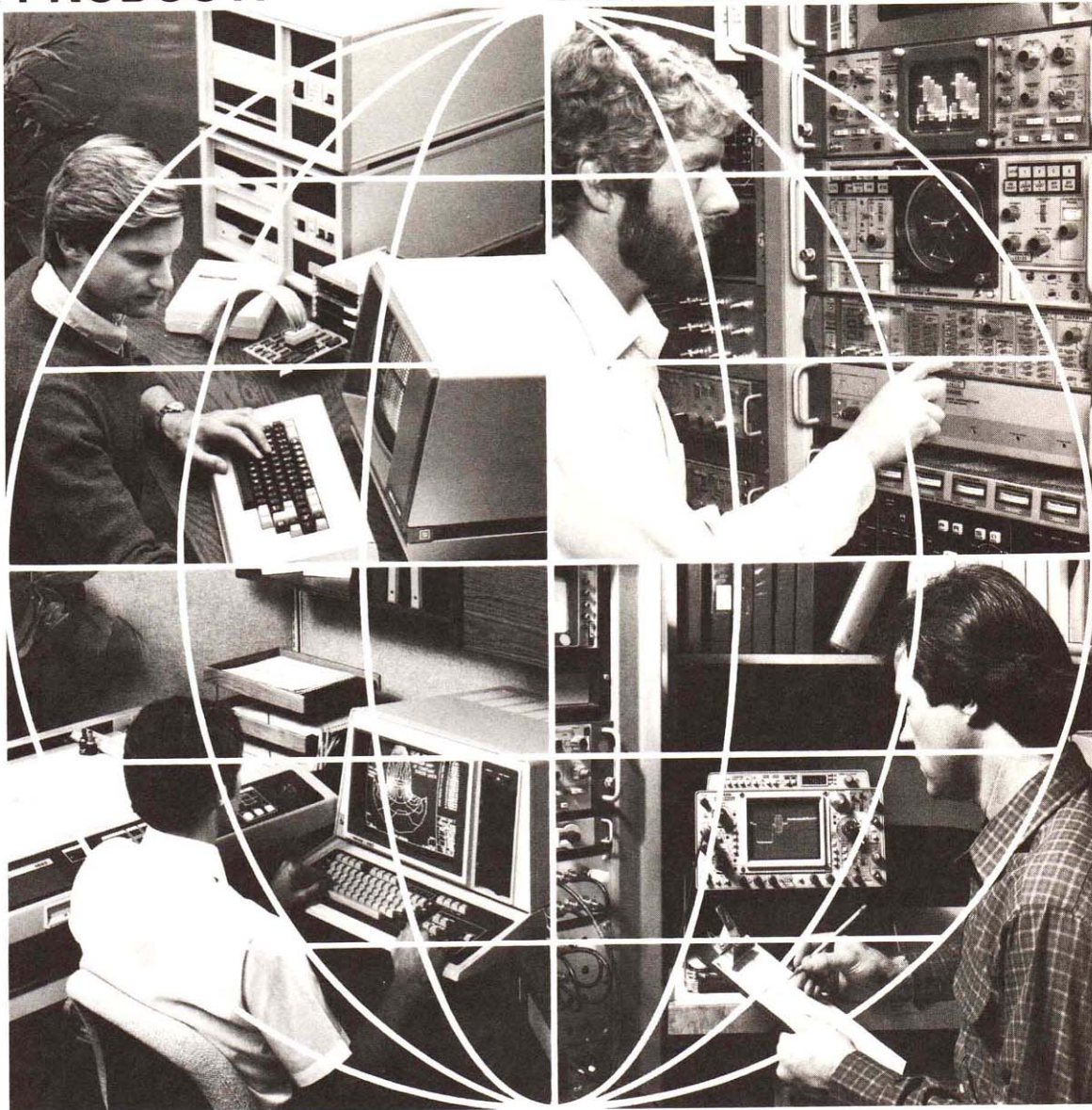

Match your own locations with ours.

No matter where in the world you put your Tek equipment to work, Tek Service is nearby.

From Australia to Zambia, at 44 Sales Offices across the U.S.A., and in 50 countries around the world, local service is at hand. Some 1400 service people the world over are dedicated to servicing Tek products exclusively.

Exceed your expected ROI.

Tektronix wants you to get the most in return for your equipment investment.

A Tektronix Maintenance Agreement is the best way to ensure that your Tek equipment will continue to perform as reliably as the day you bought it.

It provides planned, high quality service to maximize up time and prolong product life. It provides fast priority response to minimize downtime. It takes the guess-work out of service budgeting.

Call on us to solve your service problems.

Packaged with every Tektronix product is a long-term commitment to increasing its value with prompt, professional service.

Ask your Tektronix Service Representative for details on service contracts, customer maintenance training, and other convenient services to save you time and money.

We look at it this way: The better our products help you do your job, the better we're doing ours.

Tektronix
COMMITTED TO EXCELLENCE

Tektronix[®]
COMMITTED TO EXCELLENCE